

B & K

SIMPLY BETTER!

B&K Components, Ltd.

ST125.3

ST125.2

ST125.1

Owner's Manual

B&K Components, Ltd., 2100 Old Union Road, Buffalo New York 14227-2725
Phone 1-800-543-5252 or (716) 656-0026, **Fax** (716) 656-1291
E-mail: info@bkcomp.com **Web:** www.bkcomp.com

TABLE OF CONTENTS

Table of Contents	iii
Safety Precautions	1
Purpose and Function.....	2
Design and Construction	2
Features.....	2
Rear Panel	3
Level Adjustment.....	4
Inputs	4
XLR Balanced	4
RCA Unbalanced.....	4
Balanced or Unbalanced Connections.....	5
Outputs	6
System Installation	7
Making the Connection	7
Control Input and Output.....	8
Troubleshooting	9
Care and Cleaning	9
Specifications	10
Limited Warranty	11
Returning Equipment.....	11
Rear Panel Enlarged View	12
WWW.BKCOMP.COM	13

SAFETY PRECAUTIONS



PLEASE READ BEFORE INSTALLING

WARNING: to prevent fire or shock hazard, do not expose this unit to rain or moisture. Care should be taken to prevent objects or liquid from entering the enclosure. Never handle the power cord with wet hands.

- The lightning flash with arrowhead, within an equilateral triangle, is intended to alert the user of the presence of uninsulated “dangerous voltage” within the product’s enclosure that may constitute a risk of electric shock to you.
- The exclamation point within an equilateral triangle is intended to alert the user of the presence of important operating and maintenance (servicing) instructions in the literature accompanying the unit.
- Caution: To prevent the risk of electric shock, do not remove cover. No user-serviceable *parts inside*. *Refer servicing to qualified service personnel.*
- Unplug the amplifier from the AC outlet when plugging in or unplugging cables, when left unused for an extended period of time, moving the amplifier, or when you suspect lightning in your area.
- Prevent damage to the power cord. Do not bend, pull, place objects on, alter, etc. Replace the power cord if it becomes damaged. Always grasp the plug on the power cord when plugging in or unplugging the amplifier from the AC outlet.
- Your system may produce sound levels capable of causing permanent hearing loss. Do not operate for extended periods of time at high volume levels.
- Make sure the amplifier is placed on a level surface.
- The amplifier is equipped with raised feet to provide ventilation, reduce acoustic feedback, and provide protection against scratching the surface the unit is resting on. We advise against removing or altering feet.
- Do not stack anything on top of the amplifier (processor, source, etc.) Leave a minimum of 2” clearance from the top of the amplifier to the next shelf (or component) to insure proper ventilation.
- The amplifier should be located away from other sources that may be sensitive to heat.
- Do not perform any internal modifications to the amplifier.
- Always connect the amplifier’s power cord to an unswitched AC outlet for normal operation.
- If young children are present, adult supervision should be provided until the children are capable of following all rules for safe operation.
- Do not plug the amplifier’s power cord into an outlet with an unreasonable number of other devices. Be careful if using extension cords and ensure the total power used by all devices does not exceed the power rating (watts/amperes) of the extension cord. Excessive loads may cause the insulation on the cord to heat and possibly melt.
- Mistaking **CONTROL OUTPUT** or **CONTROL INPUT** connectors for audio/video inputs or outputs may damage your amplifier or other components.
- Damage can occur to your speakers if the power rating of each individual driver is exceeded by the amplifier. Ensure that all the drivers in your system are capable of handling not only the average power being delivered by the amplifiers, but also the peak power that is likely to be generated during strong passages. If you are unsure of your speaker’s power rating, contact the speaker manufacturer or the dealer where you purchased them.
- The amplifier should be serviced by qualified personnel when:
 - A. The amplifier is not functioning properly.
 - B. Objects have entered the chassis.
 - C. The amplifier was exposed to rain or other type of moisture.
 - D. The amplifier was dropped, or the chassis is damaged.

PURPOSE AND FUNCTION

The ST125.3 (three channel), ST125.2 (two channel) and ST125.1 (mono) are high power amplifiers that are designed for use in all types of audio or audio/video systems.

DESIGN AND CONSTRUCTION

The ST125.3, ST125.2 and ST125.1 amplifiers utilize high quality electronic circuitry to achieve an environment wherein a detailed, transparent, and highly musical sound can be realized. The high quality parts complement includes: state-of-the-art solid state devices, 1% metal film resistors, computer grade electrolytic power supply capacitors, and a high capacity toroidal transformer.

The ST125.3, ST125.2 and ST125.1 operate with a class A predriver and AB MOSFET power output stages. These high power amplifiers are capable of delivering their full rated power while reproducing the most demanding music passages effortlessly into the most demanding audiophile speakers.

FEATURES

Control Output - one 3.5 mm 12 VDC @ 125 mA output for turning on amplifiers and controlling external systems such as a projection screen or B & K amplifier.

Control Input - one 3.5 mm jack that allows standby on/off with a 5-24 VDC control signal.

Gold Plated Connectors - better sound with minimum signal loss and degradation.

Toroidal Transformer - Efficient, high current, shielded transformer that supplies the amplifier with a clean and constant supply of power, even during highly demanding source material passages.

Discrete Circuitry - Dynamically provides a full, accurate, and three dimensional reproduction of source material.

Class A Predriver - Improves low level detail and clarity for smoother, more musical sound.

AB MOSFET Output Stage - Provides efficient and linear power delivery, as well as protection from thermal overload.

1% Metal Film Resistors - Higher quality resistors for lower noise, better sound, and a greater degree of repeatability.

High Current - Ability to cleanly, accurately, and reliably reproduce demanding recordings or source materials into low impedance drivers and speaker systems.

Computer Grade Capacitors - Large capacity computer grade electrolytic capacitors for extended low frequency control, increased power supply, and improved dynamics.

REAR PANEL

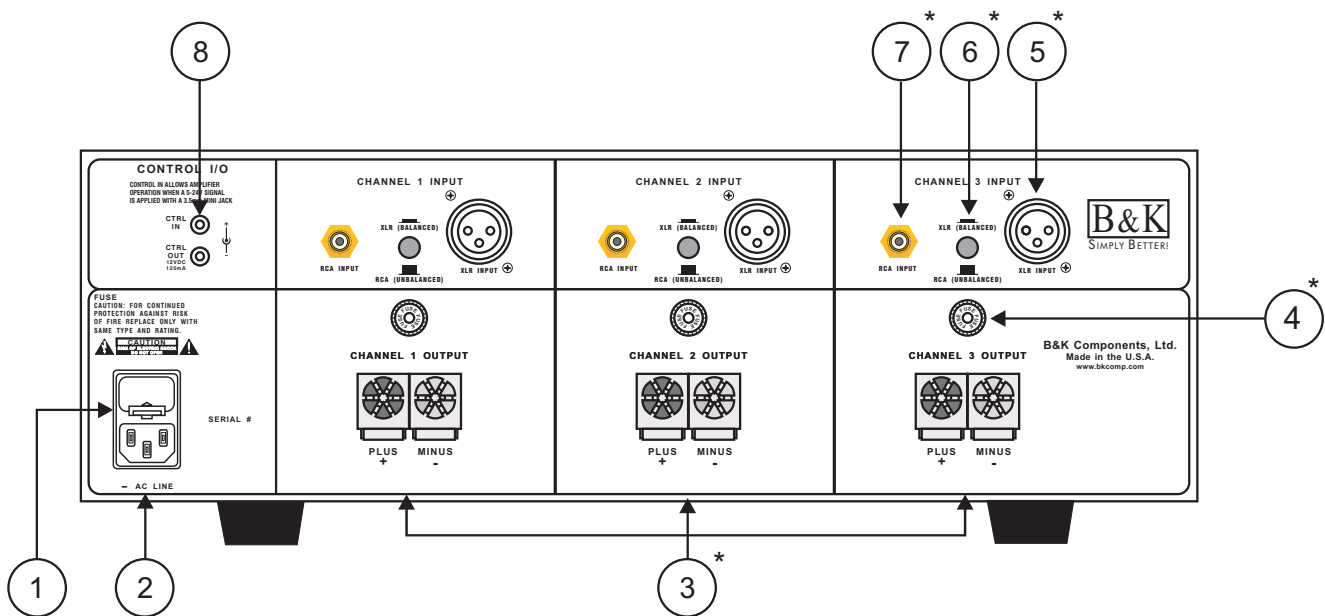

1. AC Fuse Holder - holds the AC Line fuse. This fuse is a 15 Amp / 250 Volt Slow Bow fuse. Replace only with the same type and value fuse.

2. AC Input Receptacle - for attaching the supplied AC power cord to the amplifier.

3. Speaker Outputs - for connecting the speakers to the amplifier. Explained further on page 6. * On the ST125.2, channel 3 is not available. On the ST125.1 mono amplifier, all output channels source the same information with the speaker outputs remaining fused independently.

4. Speaker Fuses - for protection against amplifier damage in the case of shorted speaker wires. Replace fuse with the same type and value 6 AMP T-Lag. * On the ST125.2, channel 3 is not available. On the ST125.1 mono amplifier, all outputs remain fused independently.

5. Balanced Input - for connecting signal patch cables (interconnects) from the preamplifier to the amplifier. Explained further on Page 4. * On the ST125.2, channel 3 is not available. On the ST125.1 mono amplifier, channels 2 and 3's XLR Balanced connections are not available.

6. Balanced/Unbalanced Input Select - this switch is used to configure an AMPLIFIER PAIR for use as either balanced (XLR) or RCA unbalanced line inputs. This switch controls two amplifier channels and allows signal patch cables (interconnects) to be sourced from either balanced or unbalanced, preamplifier/processor or line outputs. Explained further on Page 4. * On the ST125.2, channel 3 is not available. On the ST125.1 mono amplifier, channels 2 and 3's Balanced/Unbalanced Input Selectors, are not available.

7. RCA Input - for connecting signal patch cables (interconnects) from the preamplifier to the amplifier. Explained further on Page 4. * On the ST125.2, channel 3 is not available. On the ST125.1 mono amplifier, channels 2 and 3's RCA Unbalanced connections are not available.

8. Amplifier Control Input/Output - provides remote switching of the amplifier's standby on/off feature. Explained further on page 8.

LEVEL ADJUSTMENT

Generally in a home theater application, volume level is controlled by the A/V surround processor. In a system for use with the ST125.3, ST125.2 or ST125.1, adjustment of the volume level must be performed using the external preamplifier/processor.

INPUTS

The ST125.3, ST125.2 or ST125.1, allows signal patch cables (interconnects) to be sourced from either balanced or unbalanced line level preamplifier/processor outputs. A switch is used to configure a PAIR of AMPLIFIER CHANNELS for use with either balanced (XLR) or RCA unbalanced preamplifier/processor line outputs.

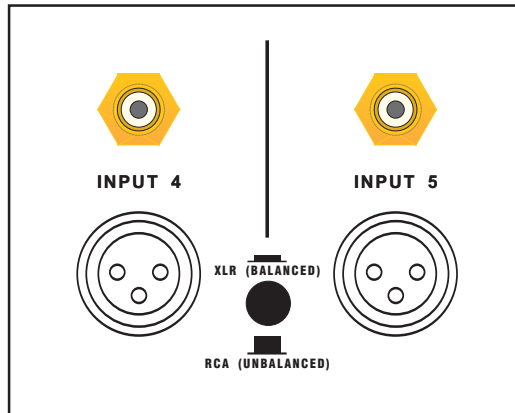

XLR BALANCED

There are up to 3 balanced input connectors on the ST125.3, ST125.2 and ST125.1. These connectors accept balanced line level output from the preamplifier's balanced output connectors.

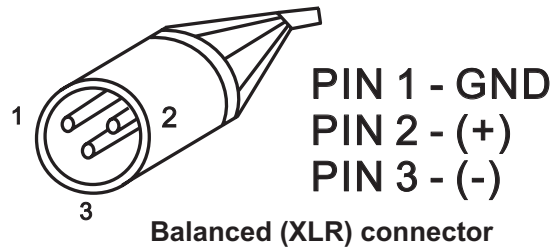

RCA UNBALANCED

There are up to three RCA unbalanced input connectors on a ST125.3, ST125.2 and ST125.1. These connectors accept RCA unbalanced line level output from the preamplifier's RCA output connectors.

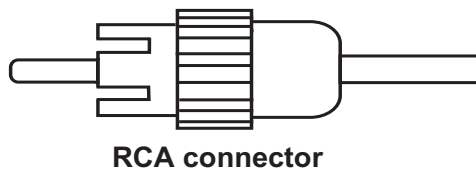

BALANCED OR UNBALANCED CONNECTIONS

Shown below are typical preamplifier to amplifier connections:

RCA Unbalanced Connections

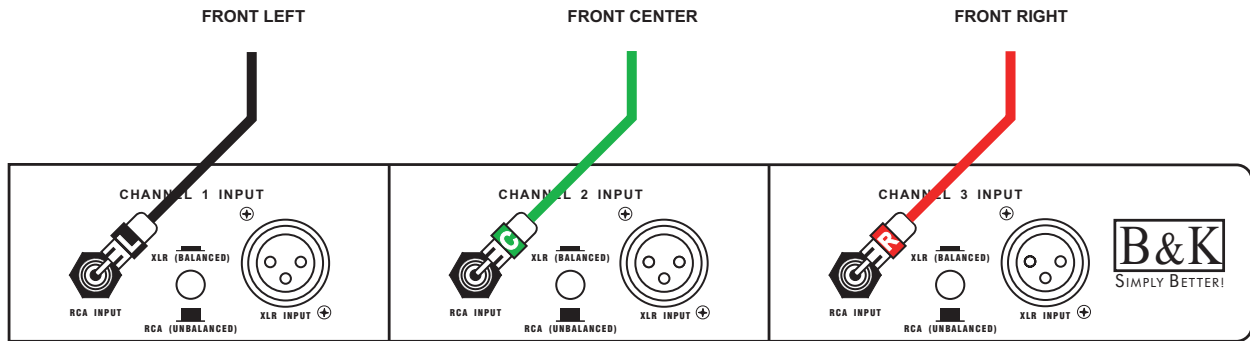

OR

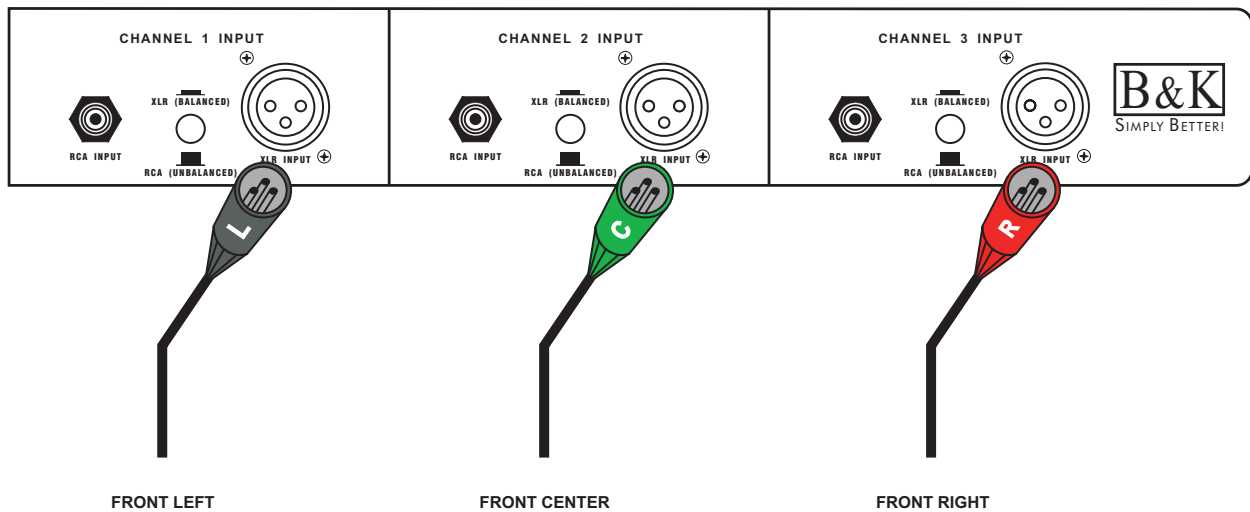

XLR Balanced Connections

OUTPUTS

Five way binding posts are provided. There is one pair provided for each channel. They are designed to accept a banana-type plug, spade-lug connector (shown below), terminal posts, and bare wire, and they are color coded for easy identification. The positive (+) post should always be connected to the speakers (+) jack. The negative (-) post should always be connected to the speakers (-) jack.

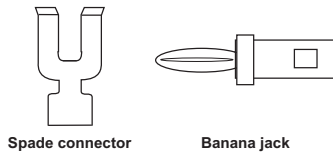

Shown below is the amplifier to speaker connections:

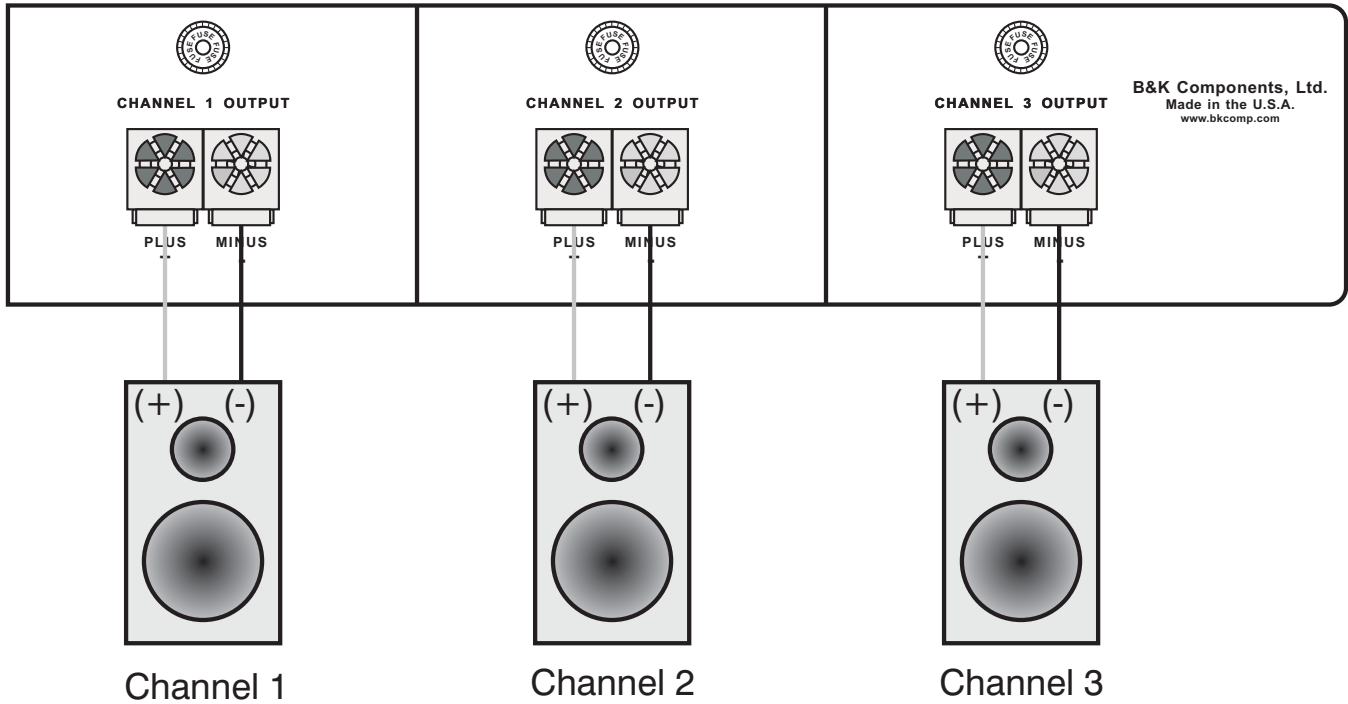

SYSTEM INSTALLATION

There will most likely be a number of cables involved in the installation of your home entertainment system. Preplanning is essential in order to maximize system efficiency. We recommend the following as a means of helping you reach that goal.

- Make a diagram of your proposed system by laying out the relative location of each component in the system. Then lay out the proposed cable runs between them. Number each cable and record its length on the diagram for future use.
- Cable runs are critical in that they must be kept away from the sources of power radiation (amplifiers, power cords, heaters, appliances, etc.). For safety reasons, they should also be kept out of traffic areas.
- The process of optimizing the system will include the type of cable, the length of the run, and the obstructions it must deal with along its run. Your dealer can advise you on the products available and their relative merits. If building custom length audio cable is not your strength, your dealer should be able to help you with that as well.
- When possible, use a separate AC power line for the amplifier, one that is not shared by any other household component. **THIS IS VERY IMPORTANT!!!**

Tip: Take a piece of string (longer than the longest cable run) and mark it at each foot of length. Then do a mock cable run using the string, dressing it neatly along the way. Count the divisions to the next full foot, and add one foot to all for some movement of the components. This will provide you with ideal cable length.

MAKING THE CONNECTION

- Before doing anything, insure that the power switch on the amplifier's front panel is in the 'off' position.
- Again, it is recommended that you locate a separate AC power outlet for the amplifier, one that is **not** shared by any other audio component in the system or any other household component. This will eliminate the possibility of the amplifier 'modulating' the power being supplied to the component and compromising the signal originating from that component.
- Locate the AC power cord provided with the amplifier and plug it into the power input receptacle in the rear panel. **Do not connect it to the AC power source yet!**
- Connect the audio cable from your preamplifier's output to the corresponding input connector on the amplifier.
- Connect the wire from your speakers to the appropriate outputs on the amplifier. It is absolutely essential that you observe correct polarity in all these connections.

Example: If you connect your left output of your preamplifier to channel 4 input on the amplifier, remember to connect your left speaker wires to channel 4's outputs. Always observe polarity when connecting speakers, connect amplifiers (+) to the speakers (+) and amplifiers (-) to speakers (-).

- Double-check all connections.
- Connect a playback unit (CD, DVD, VLD, Tuner, etc.) to the preamplifier. Turn on the preamplifier, turn the volume on the preamplifier to a minimum level, and then turn on the amplifier (in that order). Set the source on the preamplifier to the playback unit you've just connected. Turn the volume up slowly and listen for music from all channels. If this is not the case, and you don't hear any sound, double-check your installation.
- Should you encounter any problem that cannot be traced to the source or the material being played, consult the "TROUBLESHOOTING" section on page 9.

Note: When turning equipment 'off', the amplifier should always be turned off **first**, then the preamplifier. **Before turning anything on, insure the preamplifier is at a low volume level.**

CONTROL INPUT AND OUTPUT

A control (trigger) system is provided on the ST125.3, ST125.2 and ST125.1 amplifiers to allow remote switching of the amplifier's standby on/off feature. The control input is designed to operate with a source (trigger) of 5-24 volts AC or DC. All B&K A/V processors and preamplifiers may easily be utilized to control this standby on/off feature.

In addition your amplifier has a control output circuit to allow control of an external device such as another power amplifier, projection screen, power strip, etc. The control output has the capability to source 12VDC @ 125 mA (on) or 0 VDC (off).

If more than one amplifier is being controlled, the control output may be extended to include each successive unit by simply connecting a 1/8" mini-jack cable from the CTRL OUT connector of the first amplifier to the CTRL IN connector of next unit (commonly referred to as 'daisy chaining'). An example of how to connect two amplifiers is illustrated in the diagram below.

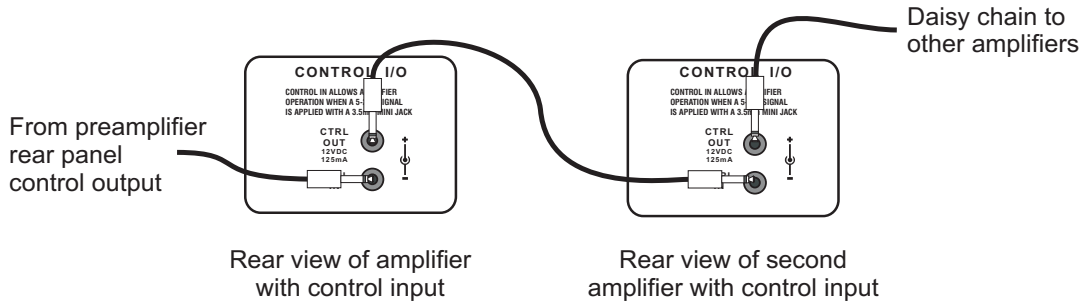

DO NOT POWER MOTORS WITH THE CONTROL OUT CIRCUIT!!!

If the control function is desired, each unit in the system must remain connected at all times and the control must be enabled. To enable the control function, the CTRL IN jack must have a 3.5mm mini-jack inserted for each controllable amplifier in the system. For more information on the amplifier's output status under various control conditions, refer to the table below.

**Note: The control input voltage is intended for standby on/off control only. For proper amplifier operation, it is recommended that each amplifier have its own source of AC power.*

@ CTRL IN	Button Position	Output Status	@CTRL OUT
Signal	OUT	Sound	Signal
Signal	IN	Sound	Signal
No Signal	OUT	Mute/Standby	No Signal
No Signal	IN	Sound	Signal

TROUBLESHOOTING

PROBLEM	POSSIBLE CAUSE	POSSIBLE SOLUTION
No sound ('on' LED not illuminated)	<ol style="list-style-type: none"> 1. Power cord not plugged in. 2. Power off at AC source. 3. AC power inlet fuse blown or faulty 4. Control Input not activated. 	<ol style="list-style-type: none"> 1. Reconnect power cord. 2. Check AC switch or fuse 3. Check for shorts or overloading 4. Supply Control IN with a 5-24 Volt AC or DC supply (Page 8)
No sound on some or all selected channels ('on' LED illuminated)	<ol style="list-style-type: none"> 1. Speaker leads loose or faulty 2. Line stage to amp cables loose or faulty 3. Source to line stage cables loose or faulty 4. Line stage or source not correctly selected 5. Speaker fuse blown 	<ol style="list-style-type: none"> 1. Tighten, repair or replace cable 2. Tighten, repair or replace cable 3. Tighten, repair or replace cable 4. Check all switch settings 5. Check all speaker fuses
Sound lacks direction, bass weak	<ol style="list-style-type: none"> 1. Speakers connected out of phase 	<ol style="list-style-type: none"> 1. Check all connections making sure that cables are connected (+) to (+) and (-) to (-)
Loud hum or buzz on one or more channels	<ol style="list-style-type: none"> 1. Poor ground connection in inter-connect cables 	<ol style="list-style-type: none"> 1. Check all connectors and repair as necessary
Channel sounds distorted and low output	<ol style="list-style-type: none"> 1. Blown rail fuse 	<ol style="list-style-type: none"> 1. Replace blown rail fuse inside amplifier.

* **Note:** If unit continues to blow power inlet fuses, **DO NOT USE A HIGHER RATED FUSE**, please contact customer service to have the unit serviced.

CARE AND CLEANING

Under normal use, the amplifier will not require any special care. Over time you may wish to clean the exterior of the unit by wiping it with a damp cloth to remove any dirt or dust that accumulates on it. Unplug the amplifier and be sure that it has completely powered down before you apply any damp cloth. Do not let any liquid enter the amplifier through the vents in the top cover. **REMEMBER, LIQUIDS CONDUCT ELECTRICITY!!!** You may clean the connectors on the back panel with isopropyl alcohol annually.

SPECIFICATIONS

Power Rating: 8 ohms - ST125.3/ST125.2/ST125.1 4 ohms - ST125.3/ST125.2/ST125.1	140/140/170 watts @ 1 kHz 185/185/225 watts @ 1 kHz
THD (S+N)	0.09 % @ 1 kHz
Frequency response	5 Hz – 45 kHz
Input sensitivity RCA unbalanced	1.4 Volts
Input sensitivity XLR balanced	2.8 Volts Pin 1 = Gnd, 2 = In +, 3 = In -
Input impedance	33.2 k ohms
Damping factor - ST125.3/ST125.2/ST125.1	100/100/180
Current (peak to peak) - ST125.3/ST125.2/ST125.1	30/30/60 Amps
Slew rate	14 V / μ sec
Dynamic headroom - ST125.3/ST125.2/ST125.1	1.0/1.4/1.5 dB
S/N (A-weighted)	95 dB
Voltage gain	28
Line voltage	120/220/240 VAC switchable
Dimensions (O.A.)	17"(w) X 16"(d) X 5.75"(h)
Weight	37 lbs. max.
Power consumption	680 watts max 7.5 Amps max current draw 60 watts @ no input
Replacement fuses	Line - 8 Amp/250 Volt Slow Blow Rails - 4 Amp/250 Volt Slow Blow

LIMITED WARRANTY

B & K Components Ltd., referred to herein as B & K, warrants your B & K equipment against all defects in material and workmanship for a period of five years from the date of purchase. This warranty applies only to the original purchaser and only to equipment in normal residential use and service. Defective equipment must be returned to B & K, prepaid, accompanied by proof of purchase and sufficient payment to cover the cost of return shipping and handling, and will be repaired or replaced at the discretion of B & K whose decision as to the method of reparation will be final.

This warranty shall not apply to any equipment which is found to have been improperly installed, incorrectly fused, misused, abused, or subjected to harmful elements, used in any way not in accordance with instructions supplied with the unit, or to have been modified, repaired or altered in any way without the expressed, written consent of B&K. This warranty does not apply to the cabinet or appearance items such as the faceplate or control buttons, nor does it cover any expenses incurred in shipping the unit to and from the manufacturer's service depot.

This warranty on B & K Components, Ltd. products is NOT VALID if the products have been purchased from an unauthorized dealer or an E-tailer or if the original factory serial number has been removed, defaced or replaced in any way. B & K Components, Ltd. sells its products through authorized dealers in order to insure that consumers obtain proper dealer service and support. Buying from an authorized B & K Components, Ltd. dealer insures that you have a FACTORY WARRANTY on your B & K Components, Ltd. product. If you have any questions concerning your Factory Warranty call B & K Components, Ltd. at 716-656-0023.

Upgradability: B & K is one the first manufacturers in the audio/video industry to consistently offer software and hardware upgrades to its processing of audio signals. Through upgrades B & K delivers exceptional value to its customers. But what is "Upgradability"? Upgradability is not a guarantee; we define it as a philosophy of designing and manufacturing products so that as audio technology evolves, B & K can provide enhancements and improvements to its products that are economically viable.

THE EXPRESS FACTORY WARRANTY HEREIN CONTAINED IS IN LIEU OF ANY AND ALL OTHER WARRANTIES, EXPRESSED OR IMPLIED, INCLUDING ANY WARRANTY OF MERCHANTABILITY, UPGRADABILITY OR OF FITNESS FOR ANY PARTICULAR PURPOSE. B&K COMPONENTS, LTD. SHALL NOT UNDER ANY CIRCUMSTANCES BE LIABLE FOR DAMAGES, INCLUDING SPECIAL, INCIDENTAL, EXEMPLARY, PUNITIVE OR CONSEQUENTIAL DAMAGES ARISING OUT OF OR IN CONNECTION WITH THE PURCHASE, USE OR PERFORMANCE OF ANY B&K PRODUCT.

This warranty gives you specific legal rights. You may also have other rights which vary from State to State. Some States do not allow the exclusion or limitation of incidental or consequential damages and the foregoing exclusions may not apply to you.

No agent, representative, dealer or employee of B&K has the authority to increase or alter the obligations or terms of this warranty.

RETURNING EQUIPMENT

No equipment may be returned to B&K Components Ltd. without a RETURN AUTHORIZATION (RA). Should you find it necessary to return equipment to B&K, for any reason, a RETURN AUTHORIZATION (RA) number must be issued by B&K in respect of the equipment being returned. You may request an RA number by calling B&K at the numbers below. We will need the following information to issue your RA number. Please have it ready before you call.

1. Your name, address, and phone number.
2. The model and serial number of the equipment being returned.
3. A description of the problem being experienced.
4. Your sales receipt.

Your call will be referred to a Technical Service Representative who will work with you to resolve the problem. If it is determined that the unit must be returned for repair, an RA number will be issued.

B&K Components, Ltd., 2100 Old Union Road, Buffalo New York 14227-2725
Phone 1-800-543-5252 or (716) 656-0026, **Fax** (716) 656-1291
E-mail: info@bkcomp.com **Web:** www.bkcomp.com

WWW.BKCOMP.COM

B&K Components, Ltd.
2100 Old Union Road
Buffalo, New York 14227
Phone: 716 – 656 - 0026