



SERVICE
MANUAL **2216B**



marantz



model **2216B**



Stereophonic Receiver



TABLE OF CONTENTS

SECTION	PAGE
1. INTRODUCTION	1
2. SERVICE NOTES	1
3. TEST EQUIPMENT REQUIRED FOR SERVICING	2
4. AM ALIGNMENT PROCEDURE	3
5. FM ALIGNMENT PROCEDURE	3
6. POWER AMPLIFIER ADJUSTMENT	4
7. VOLTAGE CONVERSION FOR EUROPEAN MODEL	5
8. FTZ REGULATION FOR EUROPEAN MODEL	5
9. MAJOR COMPONENT LOCATIONS	6
9.1 Front Panel Adjustment and Component Locations	6
9.2 Main Chassis Component Locations (Top View)	6
9.3 Rear Panel Adjustment and Component Locations	7
9.4 Main Chassis Component Locations (Bottom View)	7
10. DIAGRAM AND COMPONENT LOCATIONS	8
10.1 FM Front End Assembly (PI00) Schematic Diagram and Component Location	8
10.2 Monitor, Hi-Filter Loudness Switches Assembly (PH01) Schematic Diagram and Component Location ...	8
10.3 Phone Equalizer Amp. Assembly (P400) Schematic Diagram and Component Location	9
10.4 Dial Lamp Assembly (PZ01) Schematic Diagram and Component Location	9
10.5 Pre & Tone Amp. Assembly (PE01) Schematic Diagram and Component Location	10
10.6 Tuner Assembly (P200) Schematic Diagram and Component Location	11
10.7 Main Amp. & Power Supply Assembly (P700) Schematic Diagram and Component Location	13
11. BLOCK DIAGRAM	15
12. CONNECTION DIAGRAMS	17
12.1 For U.S.A. & Canadian Model	17
12.2 For European Model	19
13. SCHEMATIC DIAGRAMS	21
13.1 For U.S.A. & Canadian Model	21
13.2 For European Model	23
14. EXPLODED MECHANICAL DIAGRAMS	25
14.1 Cabinet	25
14.2 Chassis	27
14.3 Rear Panel for U.S.A. & Canadian Model	29
14.4 Rear Panel for European Model	29
15. PACKING MATERIAL EXPLODED VIEW	30
16. PARTS LIST	31
17. TECHNICAL SPECIFICATIONS	39

3. TEST EQUIPMENT REQUIRED FOR SERVICING

Table 1 lists the test equipment required for servicing the Model 2216B Receiver.

Item	Manufacturer and Model No.	Use
AM Signal Generator		Signal source for AM alignment
Test Loop		Use with AM Signal Generator
FM Signal Generator MPX Signal Generator	Sound Technology Model 1000A	Signal source for FM alignment Stereo separation alignment and trouble shooting
Distortion Analyzer Audio Oscillator AC VTVM	Sound Technology Model 1700A	Distortion measurements Sinewave and squarewave signal source Voltage measurements (AC)
Oscilloscope	Tektronix Model T932 Philips Model 3232	Waveform analysis and trouble shooting and ASO alignment
Frequency Counter	Fluke Model 1900A	MPX Oscillator adjustment (VCO)
Circuit Tester		Trouble shooting
DC VTVM	Fluke Model 8000 "Digital" Simpson Model 313, Triplet Model 801	Voltage measurements (DC)
AC Wattmeter	Simpson Model 1379	Monitors primary power to amplifier
AC Ammeter	Commercial Grade (1-10A)	Monitors amplifier output under short circuit condition
Line Voltmeter	Simpson Model 1359	Monitors potential of primary power to amplifier
Variable Autotransformer	Superior Electronic Co., Powerstat Model 116B-10A	Adjusts level of primary power to amplifier
Shorting Plug	Use phono plug with 600 ohm across center pin and shell	Shorts amplifier input to eliminate noise pickup
Output Load (8 ohms, $\pm 0.5\%$, 100W)	Commercial Grade	Provides 8-ohm load for amplifier output termination
Output Load (4 ohms, $\pm 0.5\%$, 100W)	Commercial Grade	Provides 4-ohm load for amplifier output termination

4. AM ALIGNMENT PROCEDURE

4.1 AM IF ALIGNMENT

1. Connect a sweep generator to the L153 and an alignment scope to the J233.
2. Rotate each core of IF transformers L155 and L156 for the maximum height and flat top symmetrical response.

4.2 AM FREQUENCY RANGE AND TRACKING ALIGNMENT

1. Set AM signal generator to 515 kHz. Turn the tuning capacitor fully closed (place the tuning pointer at the low end) and adjust the oscillator coil L154 for maximum audio output.
2. Set the signal generator to 1650 kHz. Place the tuning pointer in the high frequency end and adjust the oscillator trimmer on the oscillator tuning capacitor for maximum audio output.
3. Repeat steps 1 and 2 until no further adjustment is necessary.
4. Set the generator to 600 kHz, tune the receiver to the same frequency and adjust a slug core of AM ferrite-rod antenna L001 for maximum output.
5. Set the generator to 1400 kHz and tune the receiver to the same frequency and adjust the trimming capacitor on the antenna tuning capacitor for maximum output.
6. Repeat procedures 4 and 5 until no further adjustment is necessary.

NOTE

During tracking alignment reduce the signal generator output as necessary to avoid AGC action.

5. FM ALIGNMENT PROCEDURE

5.1 FM FREQUENCY RANGE AND TRACKING ALIGNMENT

1. Connect an FM signal generator to the FM antenna terminals and an oscilloscope and an audio distortion analyzer to the TAPE OUT jacks on the rear panel.
2. Set the generator to 87.4 MHz and provide about 3 to 5 μV . Place the tuning pointer at the low frequency end by rotating the tuning knob and adjust the pitch of oscillator coil L107 to obtain maximum audio output.
3. Set the generator to 109 MHz and provide about 3 to 5 μV . Rotate the tuning knob and place the tuning pointer at the high frequency end and adjust the trimming capacitor C121 for maximum output.
4. Repeat steps 2 and 3 until no further adjustment is necessary.
5. Set the generator to 90 MHz and tune the receiver to the same frequency. Decrease signal generator output until the audio output level decreases with the decreasing generator output. Adjust the pitch of antenna coil L102 and RF coil L104 for maximum output.
6. Set the generator to 106 MHz and tune the receiver to the same frequency. Decrease the signal generator output until the audio output level decreases with the decreasing generator output. Adjust the trimming capacitors of antenna and RF tuning circuits for maximum output.
7. Repeat steps 5 and 6 until no further adjustment is necessary.
8. Adjust the primary core (lower core) of discriminator transformer L202 so that the center tuning meter pointer indicates its center at no signal applied. Set the FM signal generator to 98 MHz and increase its output level 1 $\text{K}\mu\text{V}$ and tune the receiver to the same frequency so that the center tuning meter pointer indicates its center. Adjust the secondary core (upper core) of L202 for minimum distortion.

5.2 STEREO SEPARATION ALIGNMENT

1. Set the FM signal generator to provide 1 $\text{K}\mu\text{V}$ at 98 MHz. Tune the receiver to the same frequency so that the center tuning meter pointer indicates its center. Then turn off the modulation of the generator, connect a frequency counter to test point J229 and adjust R301 so that the frequency counter may precisely read 76 kHz.
2. Modulate the generator with stereo composite signal consisting of only L or R channel (of course a pilot signal must be included).

3. Adjust the trimming resistor R317 for maximum and same separation in both channels.

5.3 MUTING THRESHOLD ADJUSTMENT

1. Set the FM signal generator output to provide 12.5 μ V (IHF) at 98 MHz and tune receiver to the same frequency. Adjust the trimming resistor R212 for the threshold level of 12.5 μ V. (During this adjustment turn the FM MUTING pushswitch "on".)

5.4 FM TAPE OUT LEVEL ADJUSTMENT

1. Set the FM signal generator to provide a 1000 Hz, 100% modulated 98 MHz mono signal, at 1 K μ V output. Precisely tune the receiver to 98 MHz.
2. Adjust R215 until the outputs of both channels are 1060 mV.

6. POWER AMPLIFIER ADJUSTMENT

Connect a VTVM between the test point (R731, R733) and adjust the trimming resistor R719 until the VTVM reads 9 mV DC. For the other channel, connect the VTVM between the test point (R732, R734) and adjust the R720 for the same reading.

● EUROPEAN MODEL ONLY

7. VOLTAGE CONVERSION

The European version of the Model 2216B is equipped with a universal power transformer that may be adjusted to operate at 110 V, 120 V, 220 V, or 240 V AC at 50 to 60 Hz. To convert the unit to a different power source voltage, reposition conversion plug as shown in Figure 2.

CAUTION

DISCONNECT POWER SUPPLY CORD FROM AC OUTLET BEFORE CONVERTING VOLTAGE.

Figure 2. Voltage Conversion Chart

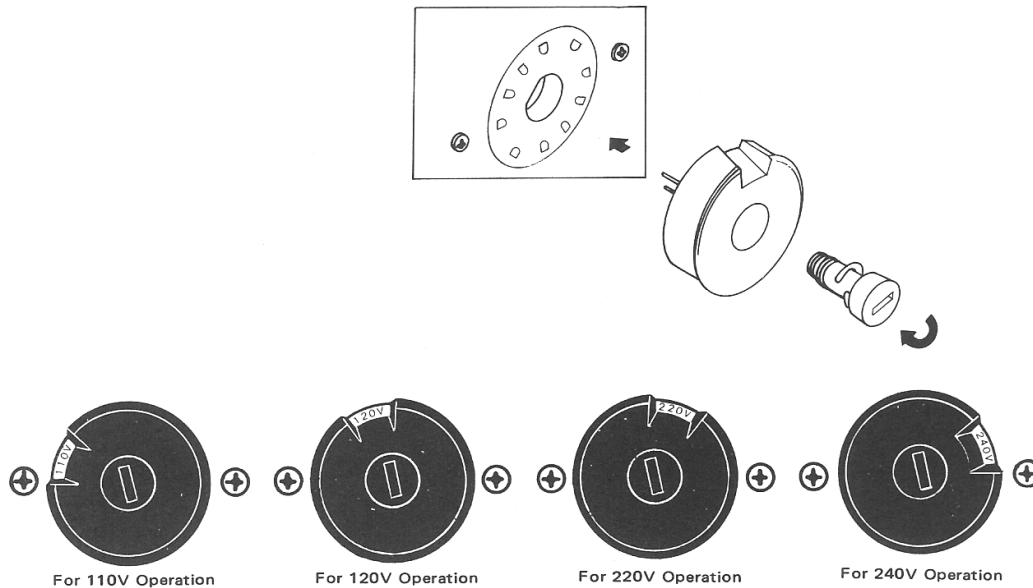

9. FTZ REGULATION

Instruction for the use
in the range other than specified in FTZ codes

Achtung für die Leute, die in dem Gebiet wohnen,
wo die FTZ-Bestimmungen vorherrschend sind.

Sollte das Gerät auch für Frequenzen ausserhalb des in den FTZ-Bestimmungen angegebenen Bereiches empfangsbereit sein, bitten wir, den Bereich durch Nachstellen des Kernes in der Oszillatorspule (in der Abbildung mit „FTZ“ gekennzeichnet) so zu korrigieren, daß er den Bestimmungen entspricht.

9. MAJOR COMPONENT LOCATIONS

9.1 Front Panel Adjustment and Component Locations

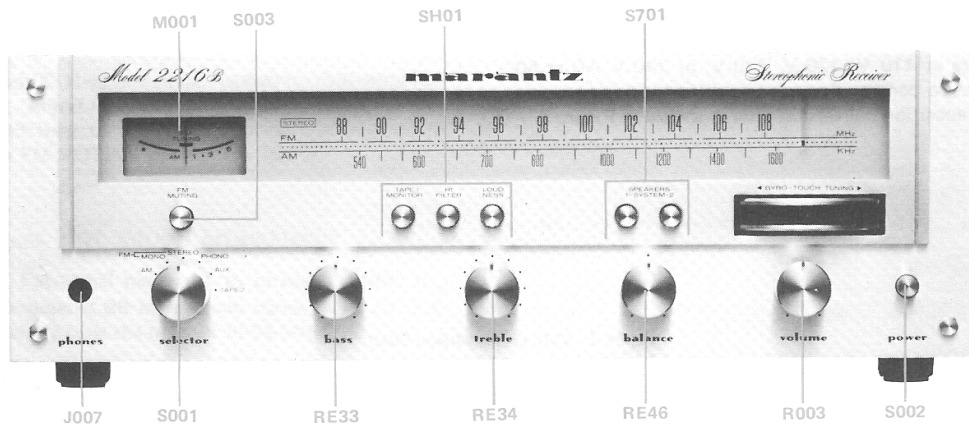

9.2 Main Chassis Component Locations (Top View)

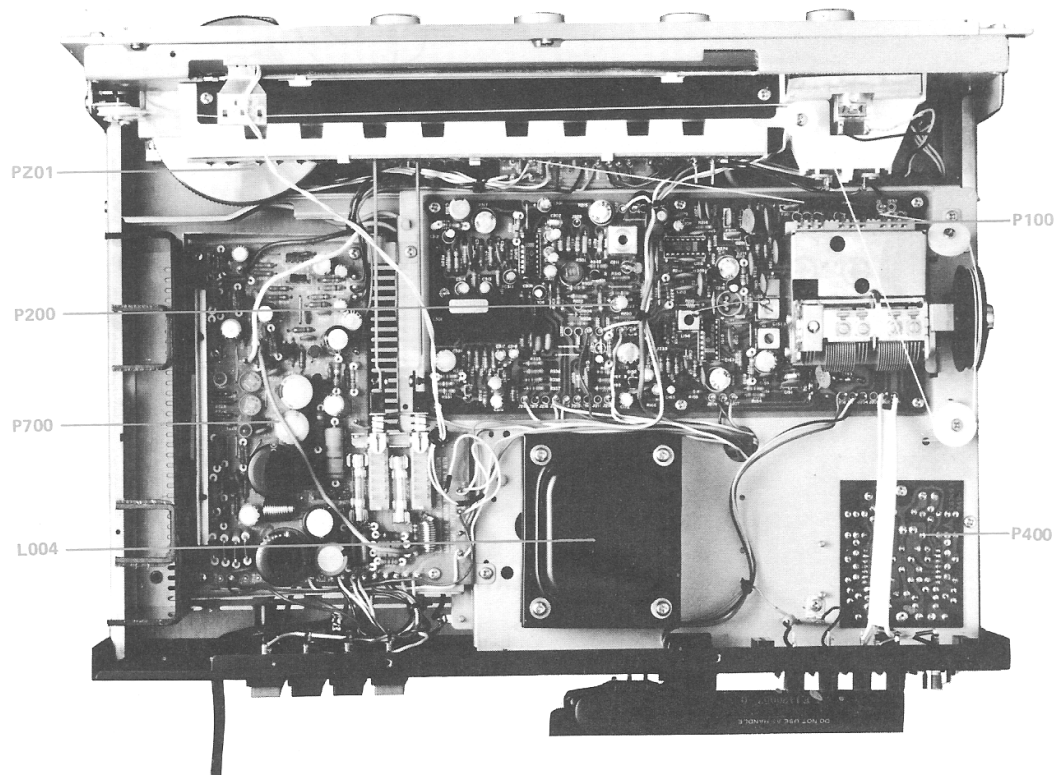

9.3 Rear Panel Adjustment and Component Locations

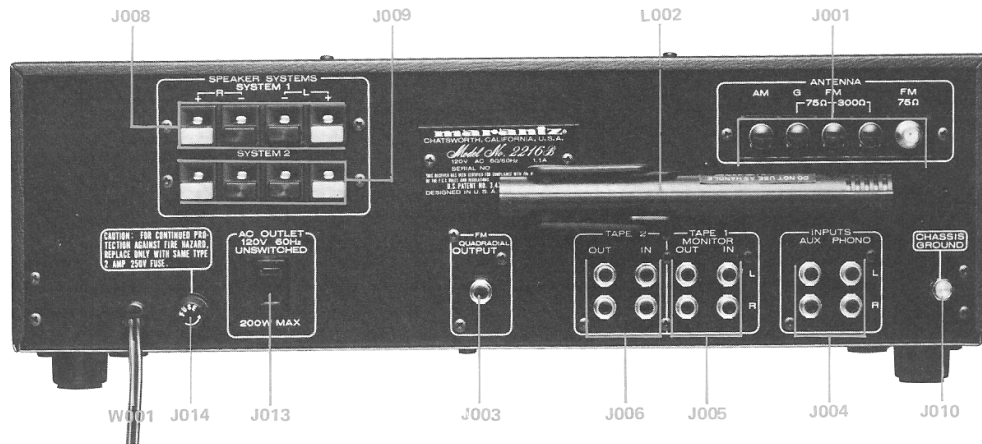

9.4 Main Chassis Component Locations (Bottom View)

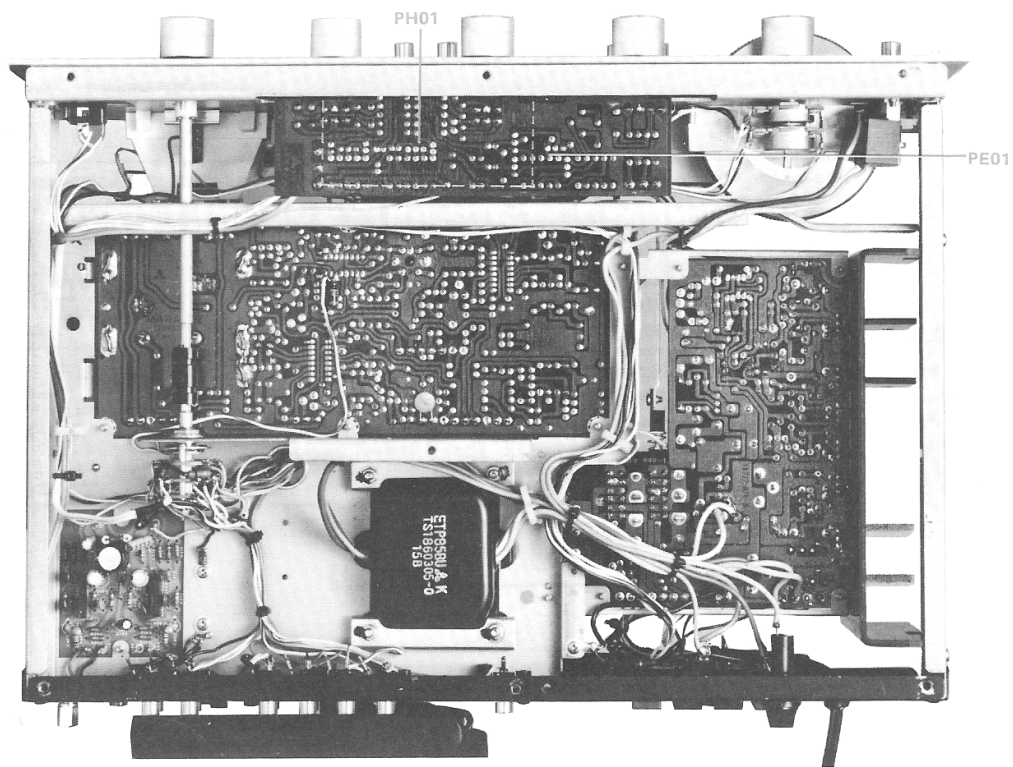

10. DIAGRAM AND COMPONENT LOCATIONS

10.1 FM Front End Assembly (PI00) Schematic Diagram and Component Location

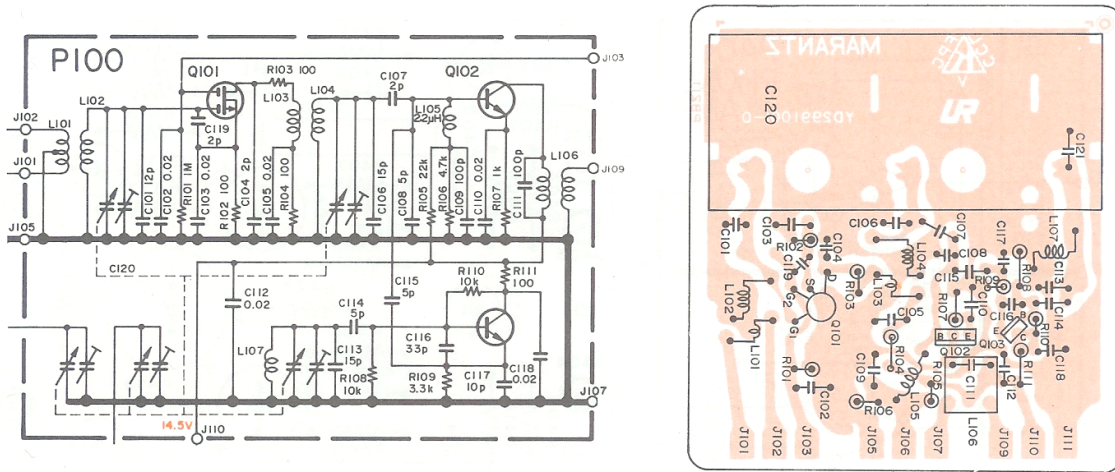

10.2 Monitor, Hi-Filter Loudness Switches Assembly (PH01) Schematic Diagram and Component Location

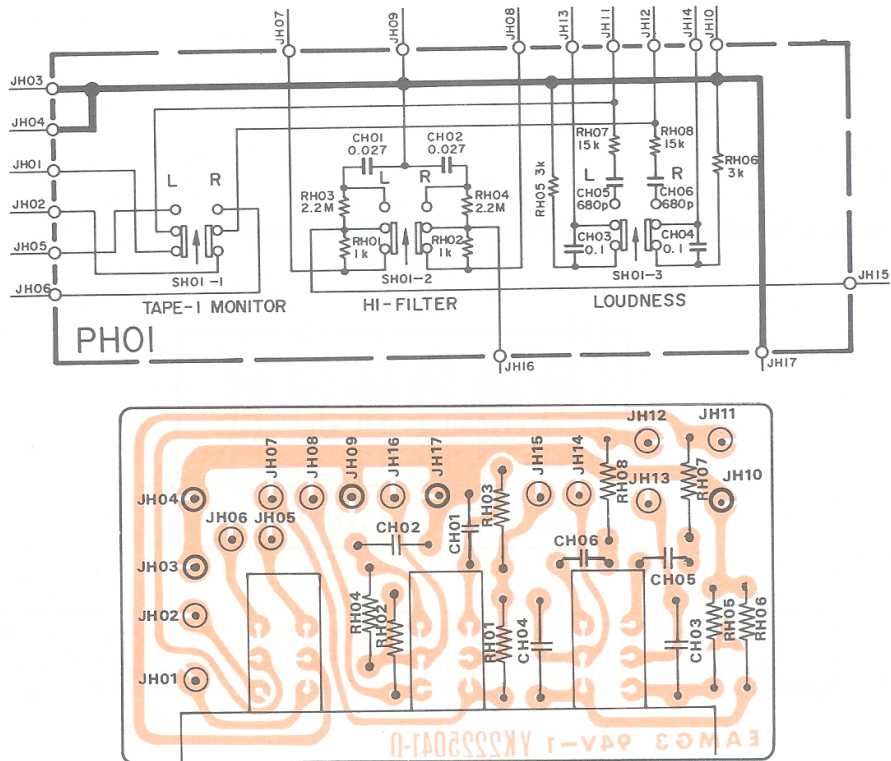

10.5 Pre & Tone Amp. Assembly (PE01) Schematic Diagram and Component Location

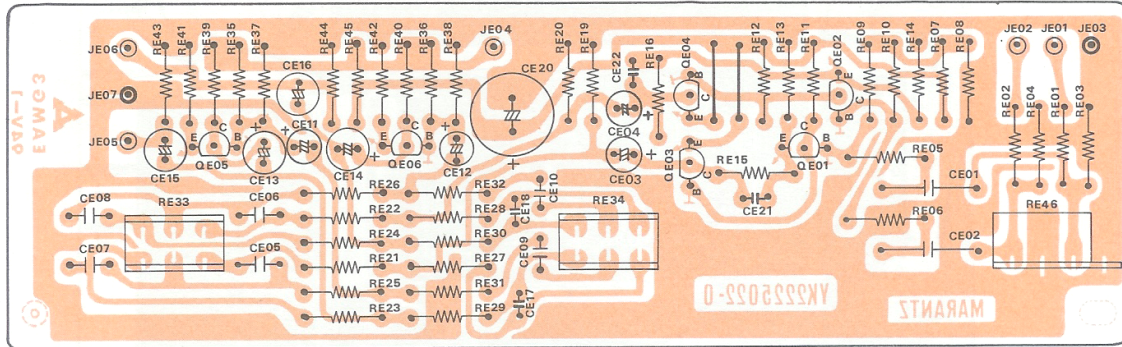
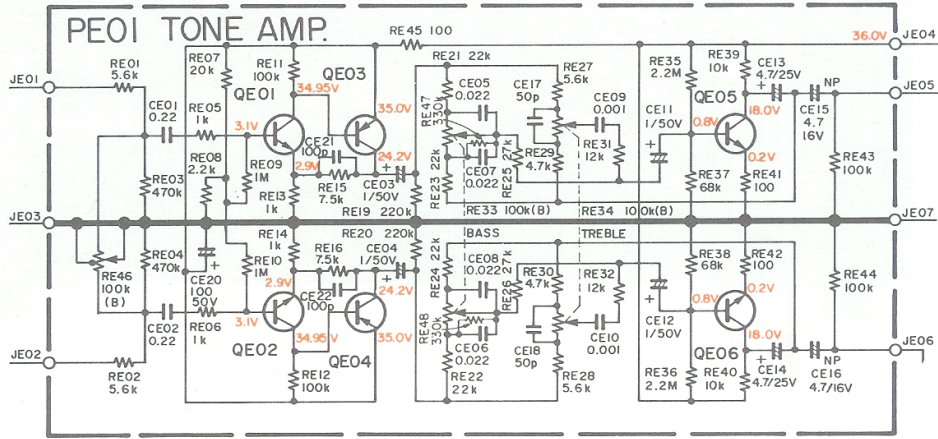

10.6 Tuner Assembly (P200) Schematic Diagram and Component Location

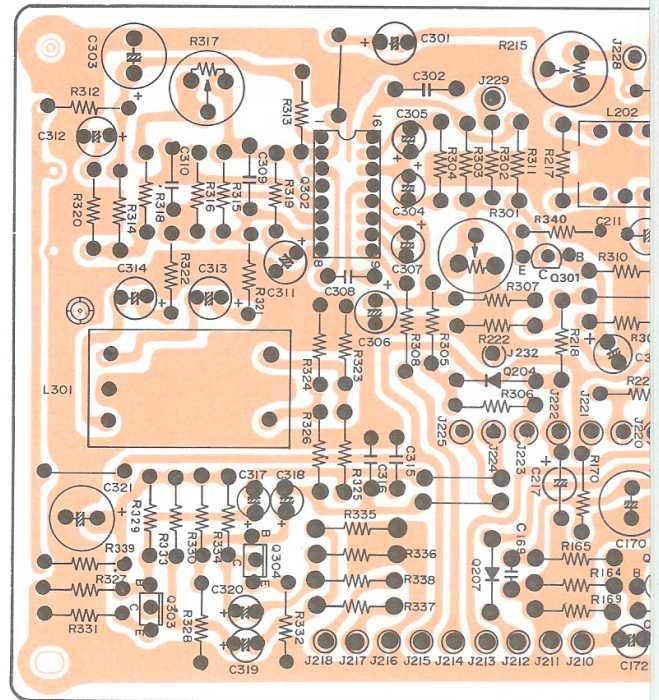
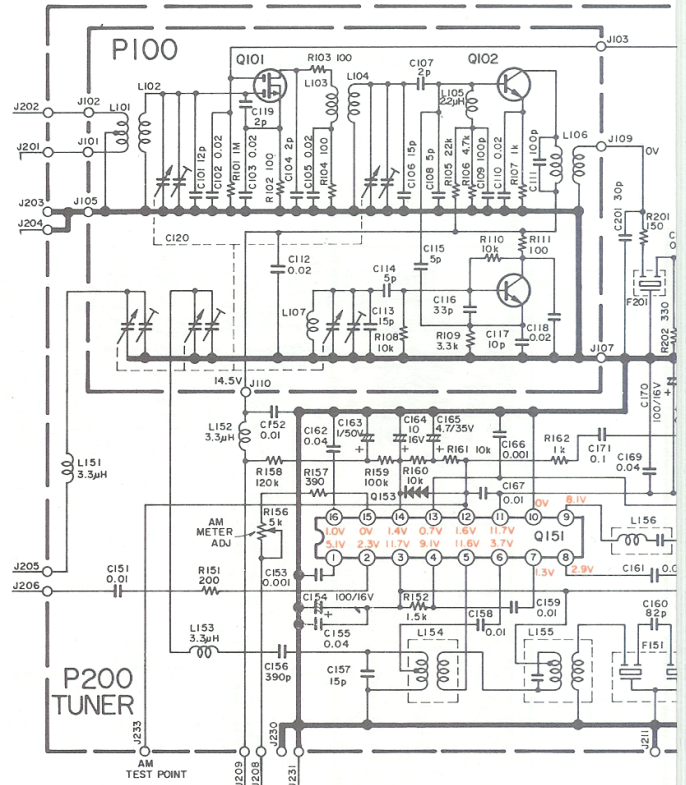

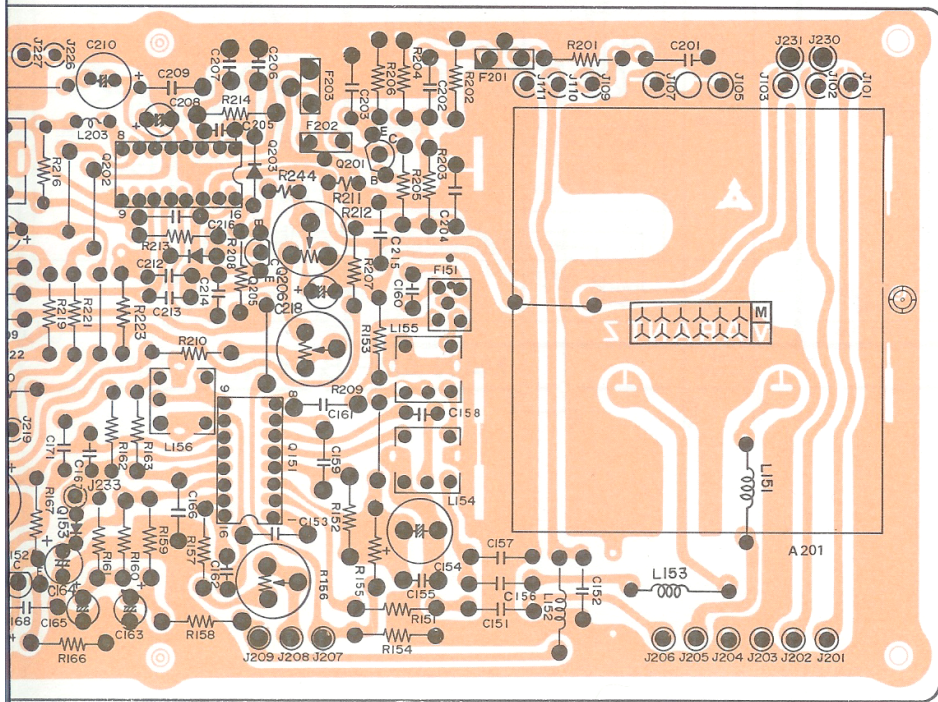
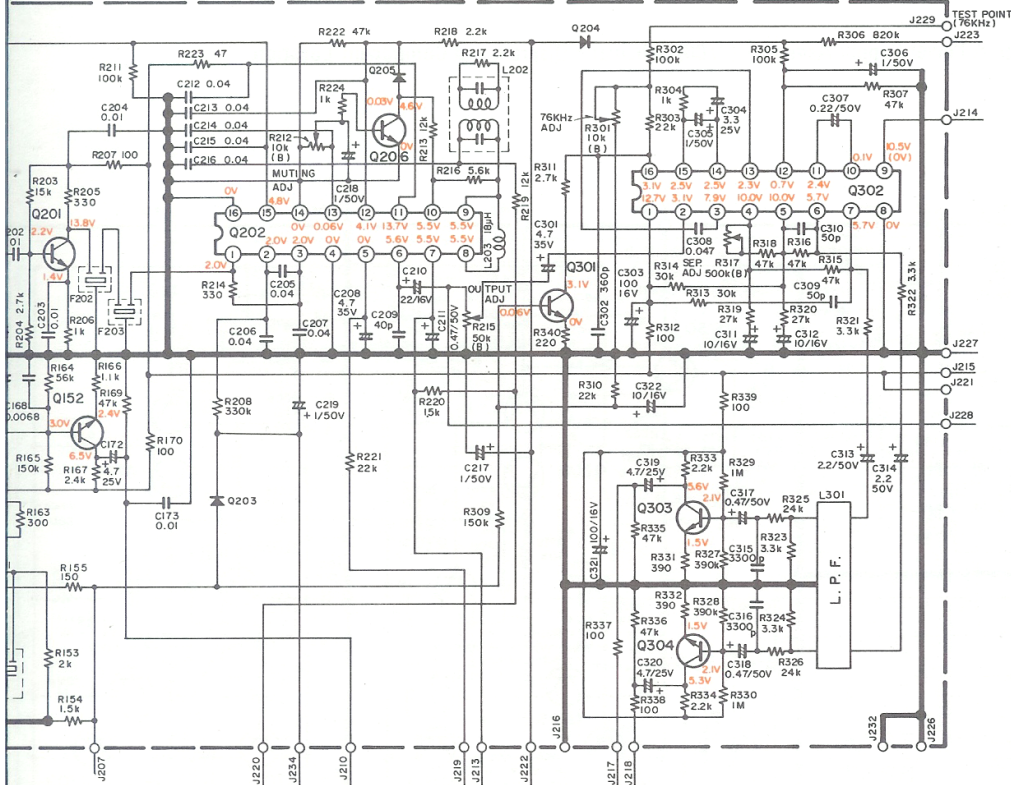

10.7 Main Amp. & Power Supply Assembly (P700) Schematic Diagram and Component Location

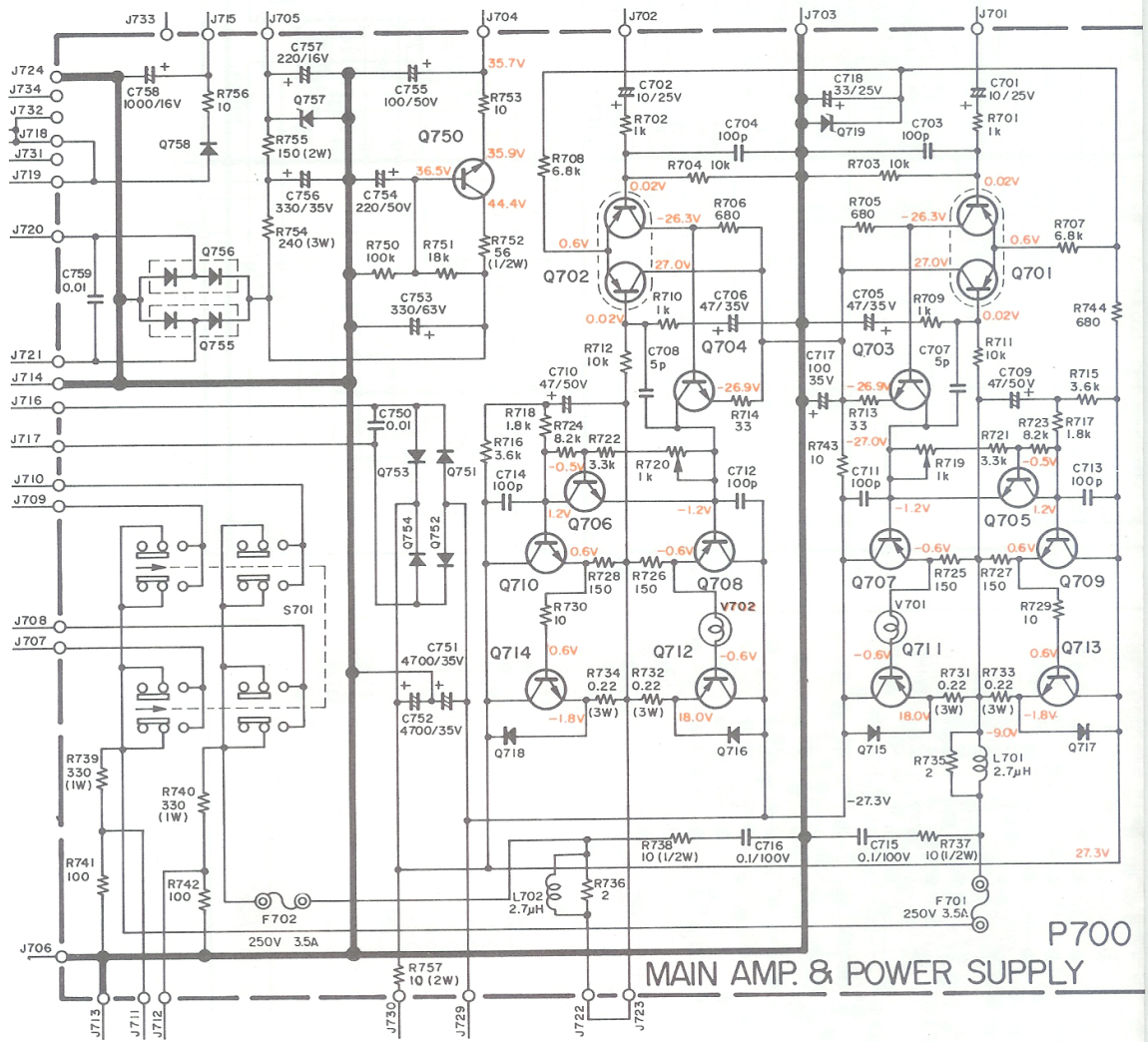

11. BLOCK DIAGRAM

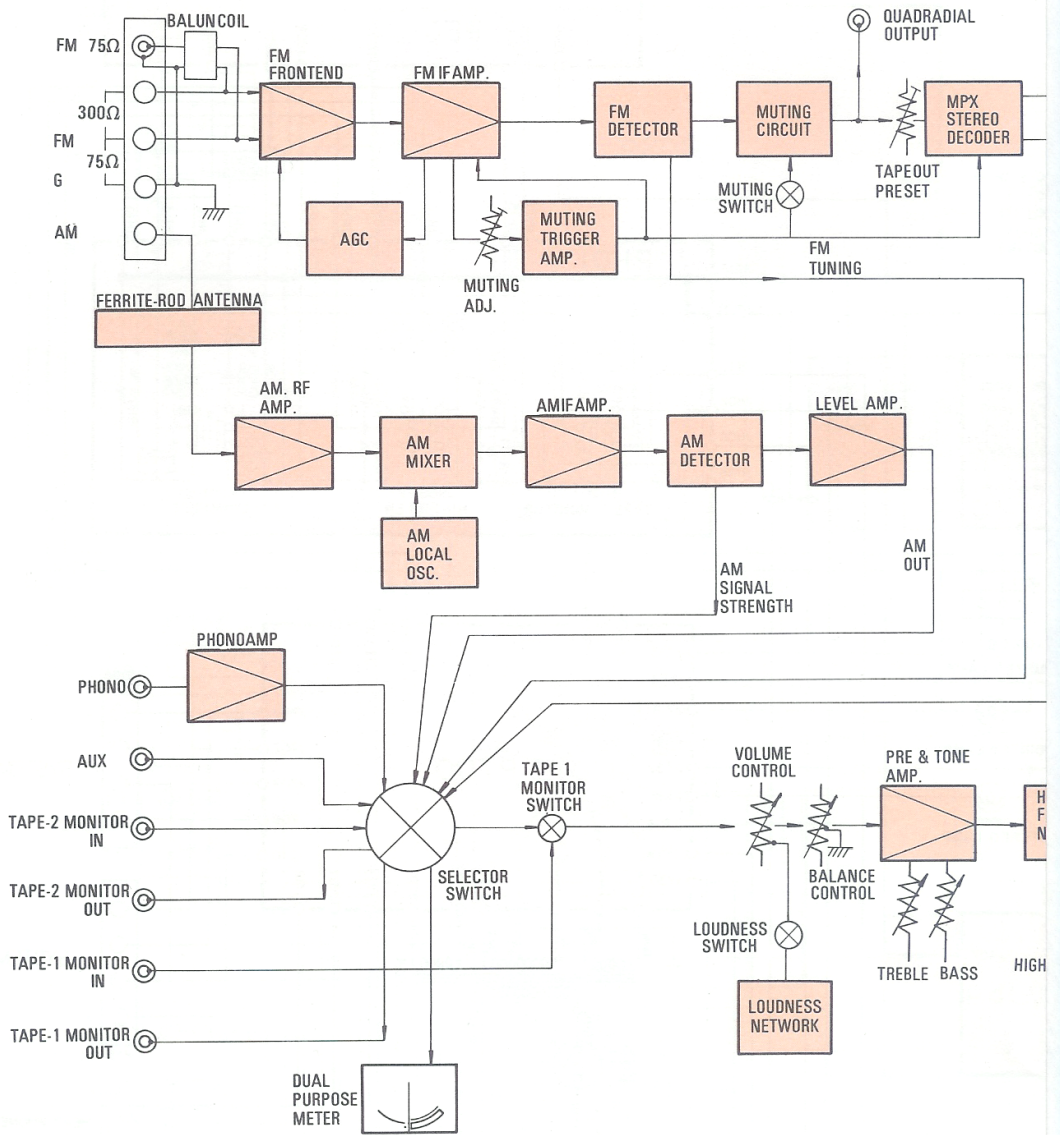

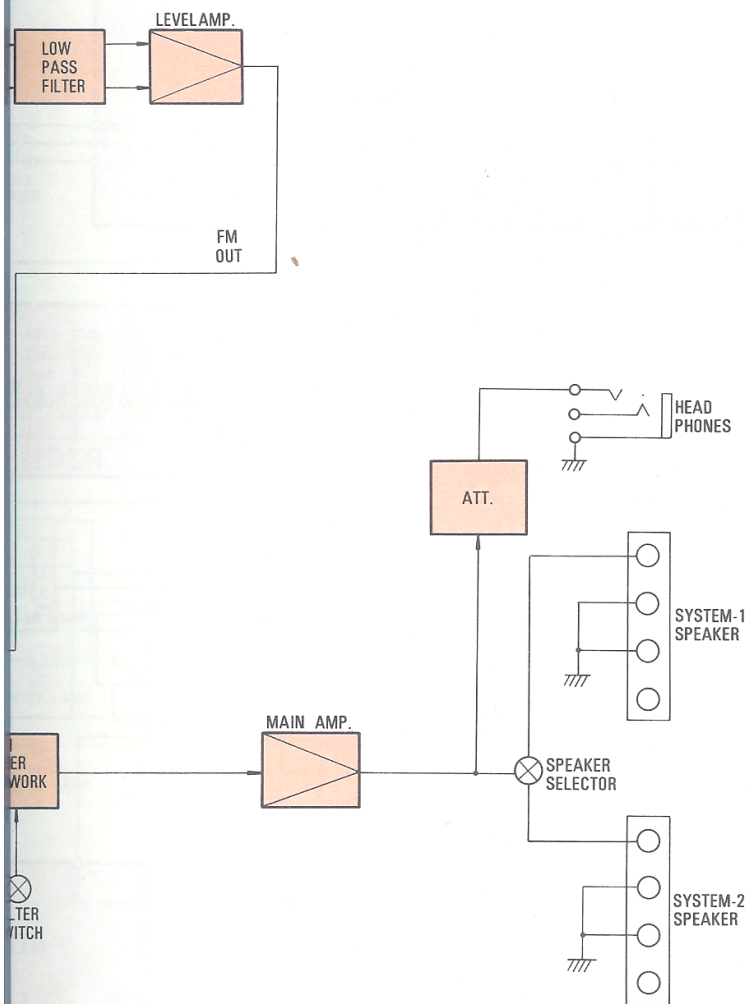

12. CONNECTION DIAGRAMS

12.1 For U.S.A. & Canadian Model

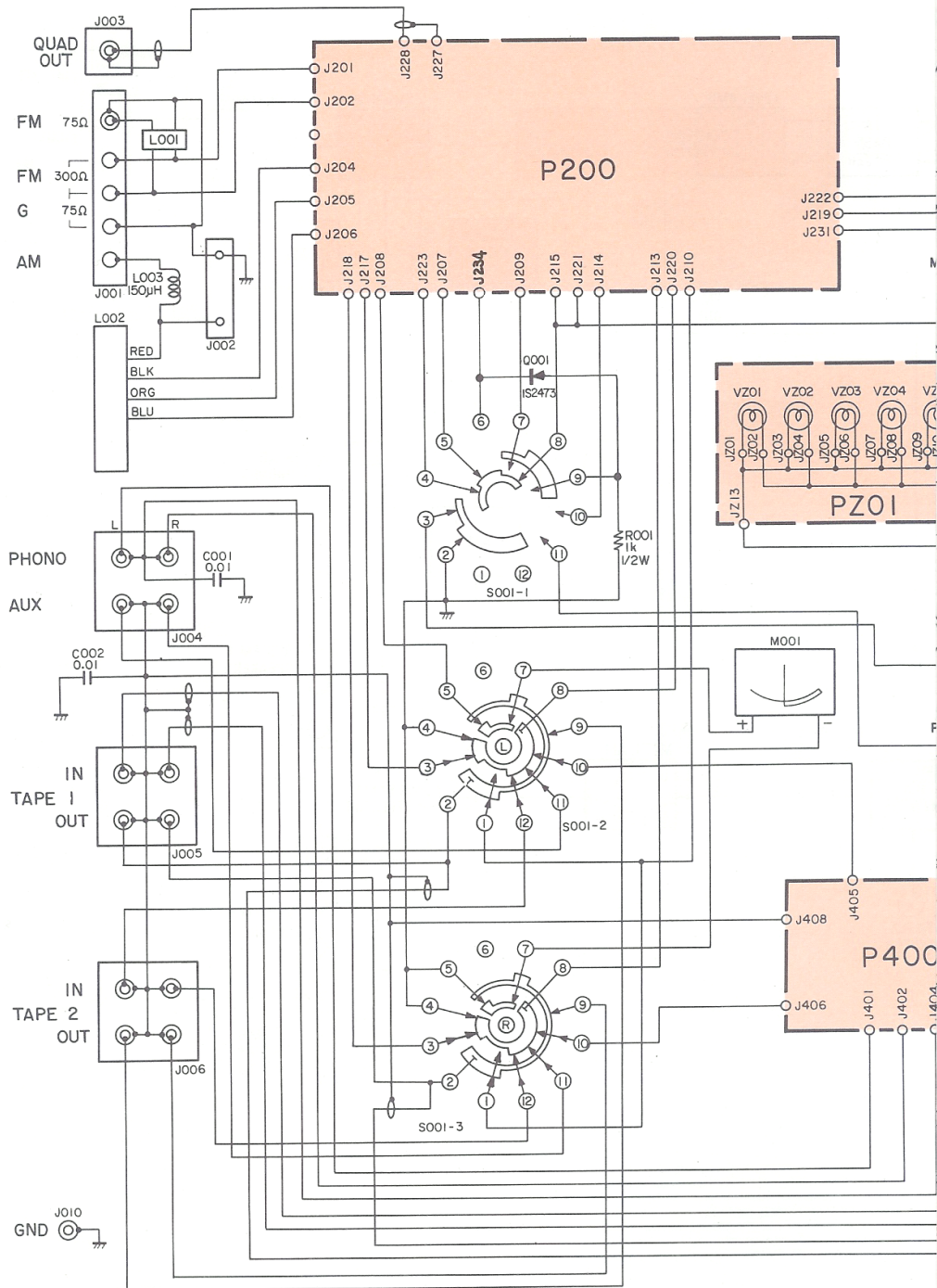

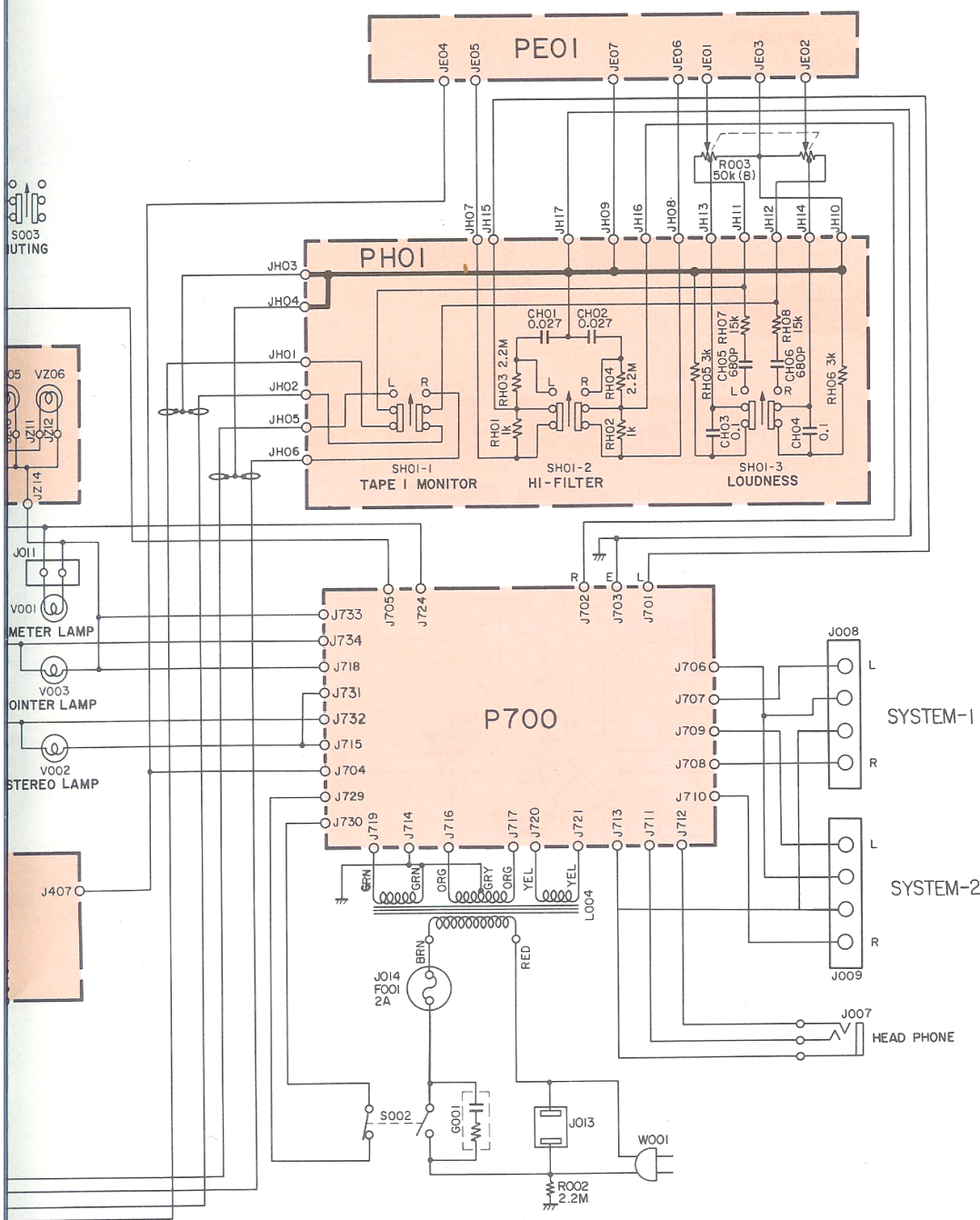

12.2 For European Model

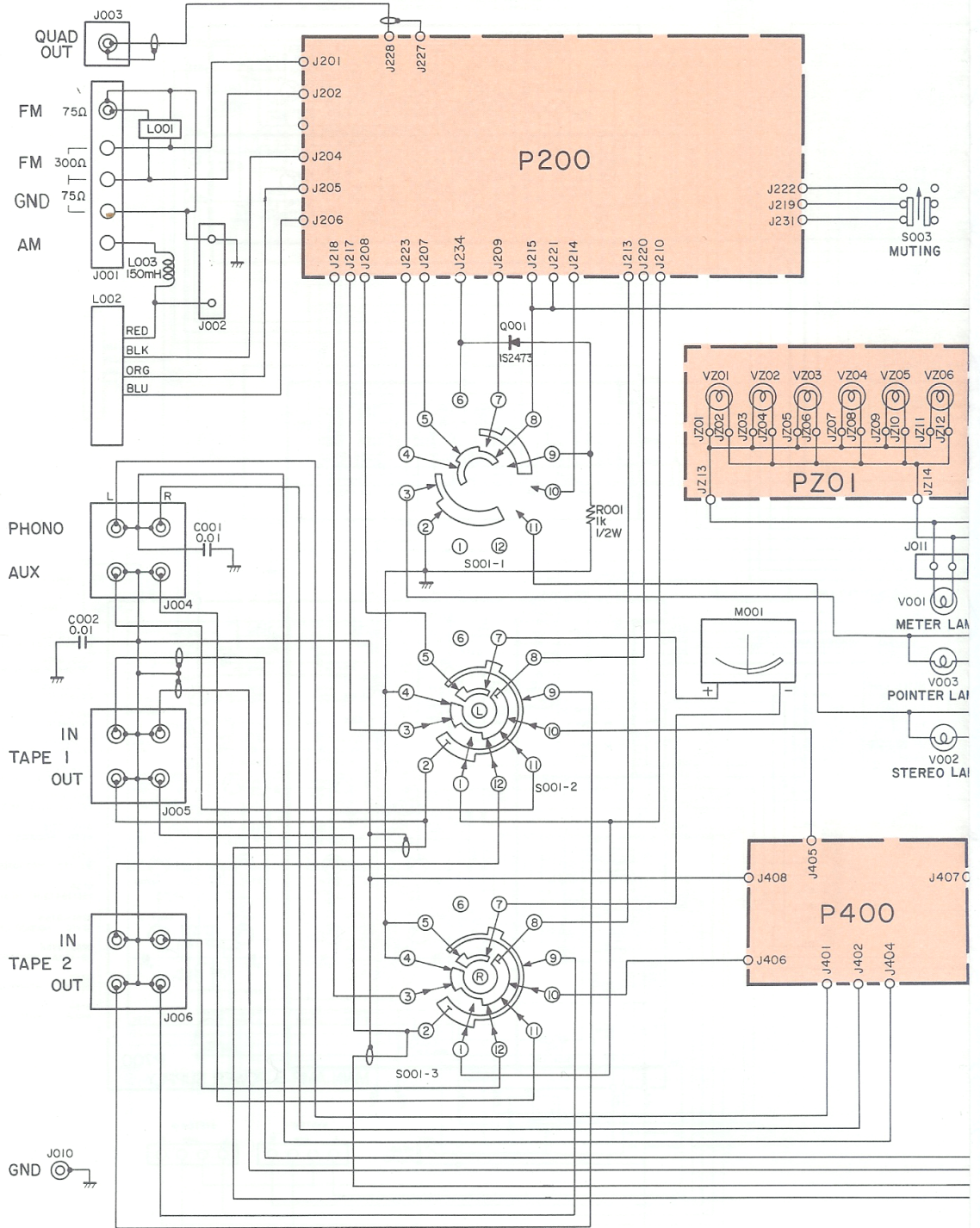

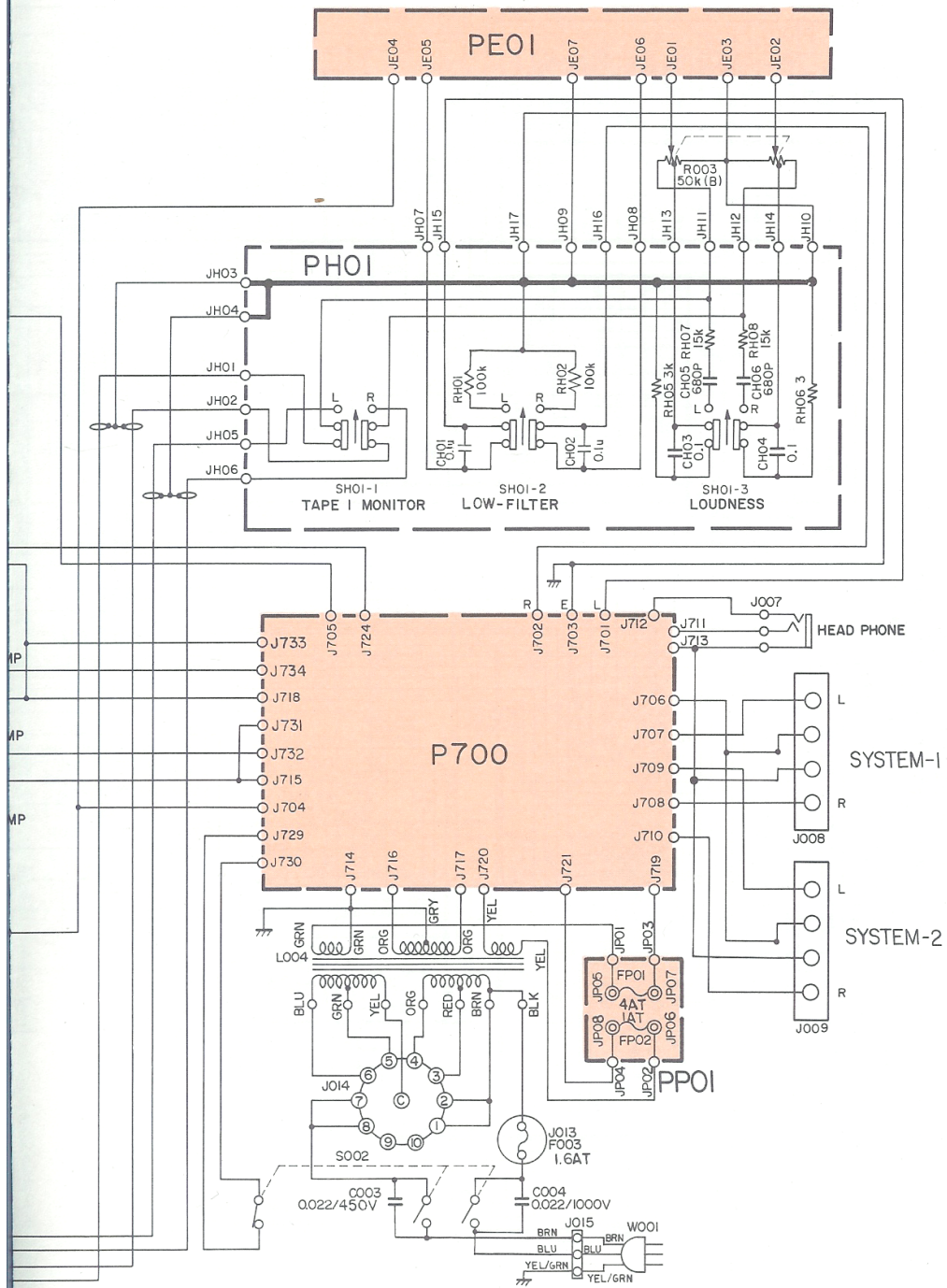

13. SCHEMATIC DIAGRAMS

13.1 For U.S.A. & Canadian Model

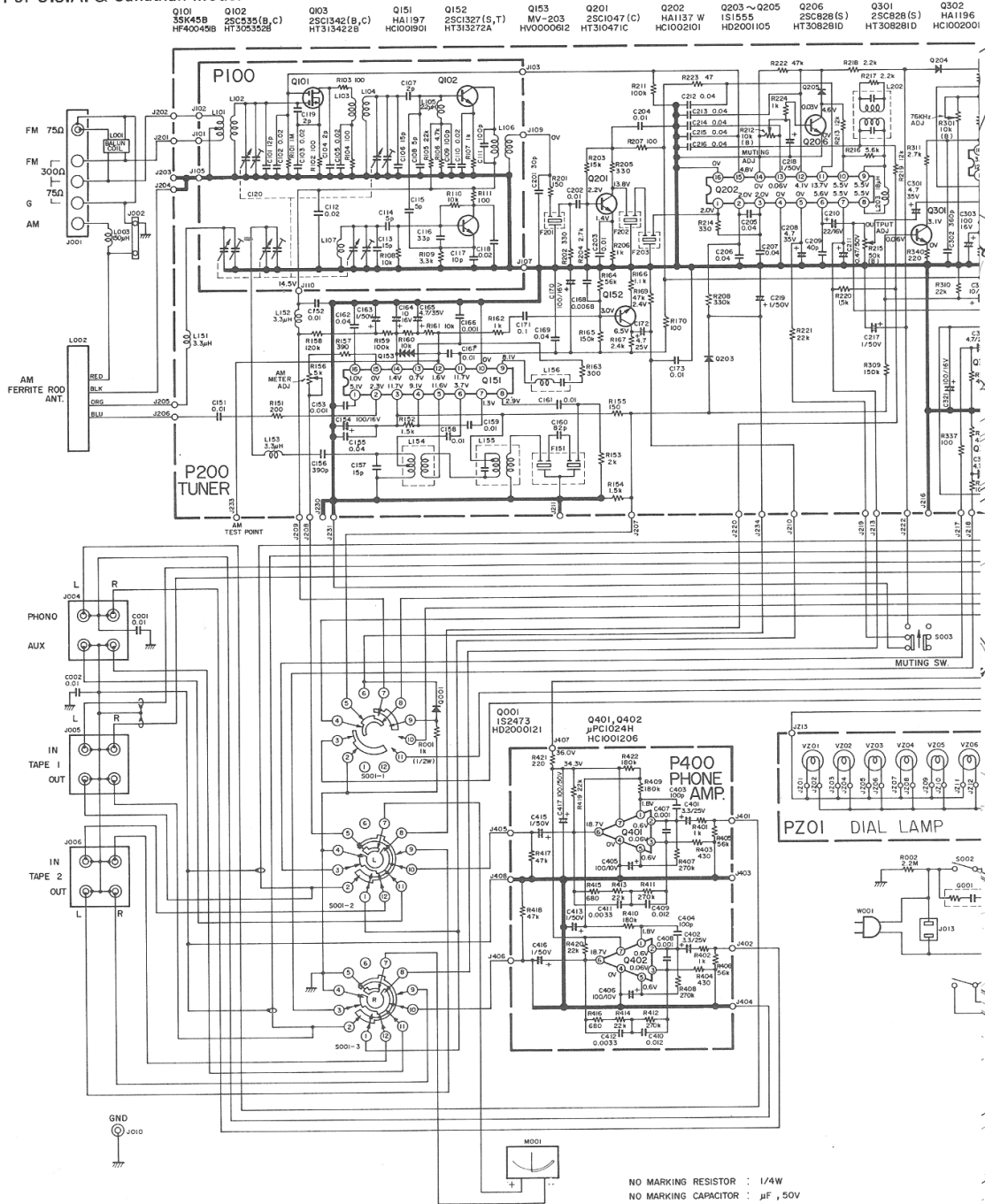

Model 2216B

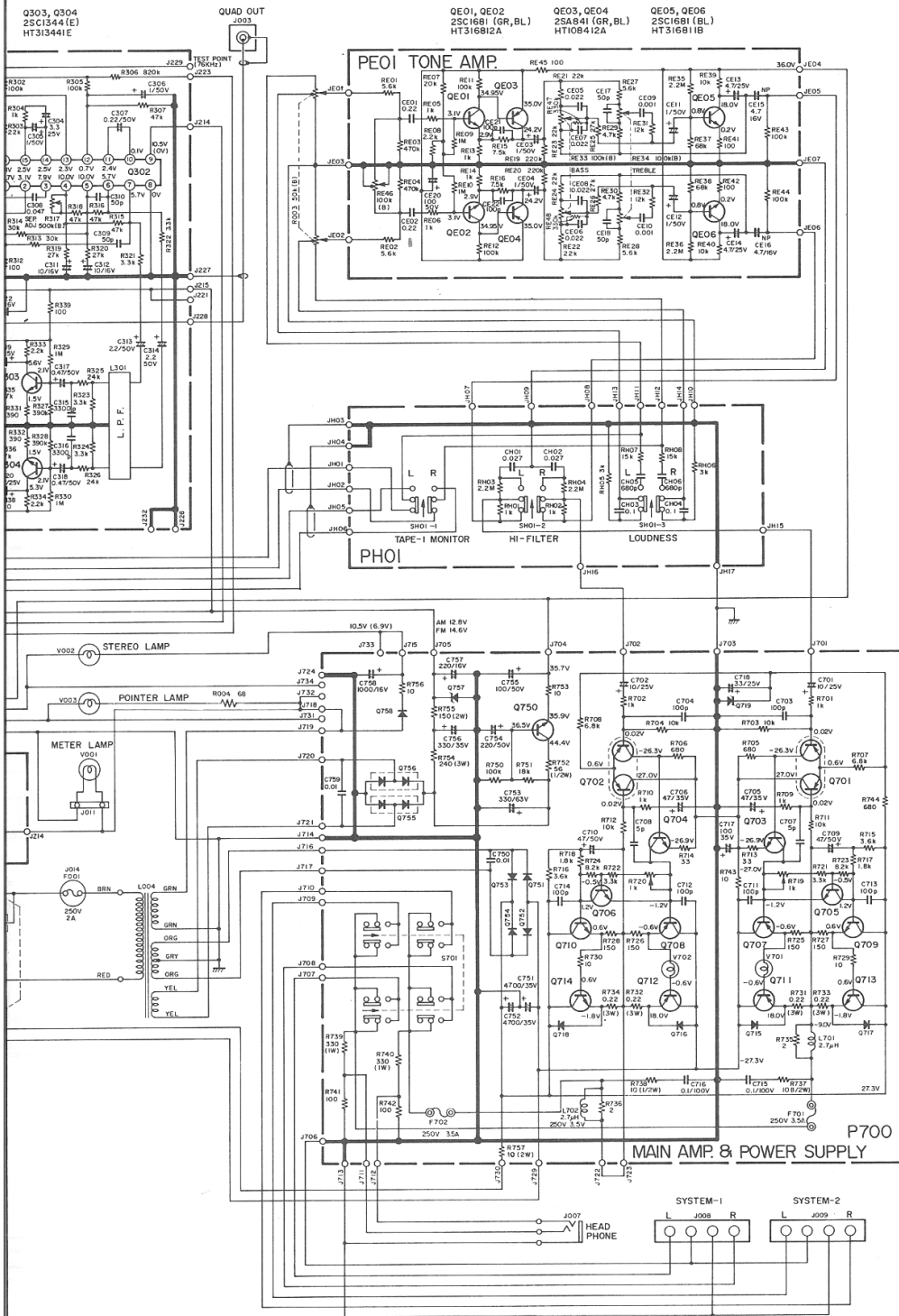

- Q701, Q702 2SA798 (F,S) HT107982A
- Q703, Q704 2SC1384 (R,S) HT313842C
- Q705, Q706 2SC945 (Q) HT309451Q
- Q707, Q708 2SA684 (Q,R) HK138419F
- Q709, Q710 2SC1384 (Q,R) HK138419F
- Q711, Q712 2SB507 (D,E) HK050719A
- Q713, Q714 2SD313 (D,E) HK050719A
- Q715-Q718 W06B HD2000501
- Q719 WZ-177 HD3003009
- Q750 2SC1384 (O,R) HT313842B
- Q751-Q754 53V10 HD2000729
- Q755, Q756 DS-133A HD2000803
- Q757 BZ-140 HD3002109
- Q758 W06B HD2000501

Model 2216B

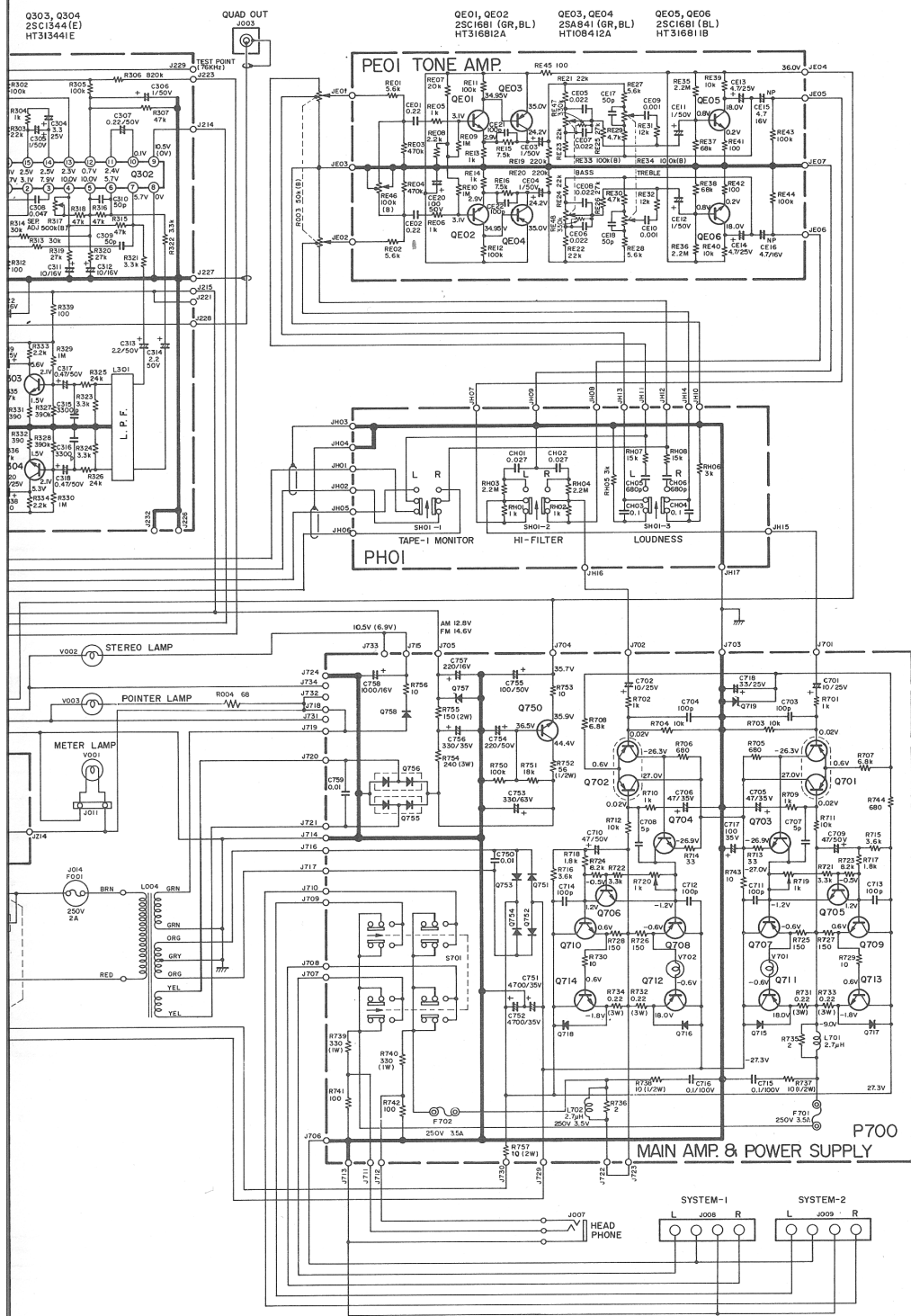

- Q701, Q702 25A798 (F,G) HT107982A
- Q703, Q704 25C1384 (R,S) HT13842C
- Q705, Q706 25C945 (O) HT309451Q
- Q707, Q708 25A684 (Q,R) HK138419F
- Q709, Q710 25C1384 (Q,R) HK138419F
- Q711, Q712 25B507 (D,E) HK050719A
- Q713, Q714 25D313 (D,E) HK050719A
- Q715~Q718 W068 HD2000501
- Q719 WZ-177 HD3003009
- Q750 25C1384 (Q,R) HT13842B
- Q751~Q754 S3V10 HD2000729
- Q755, Q756 DS-133A HD2000803
- Q757 BZ-140 HD3002109
- Q758 W068 HD2000501

13. SCHEMATIC DIAGRAMS

13.1 For U.S.A. & Canadian Model

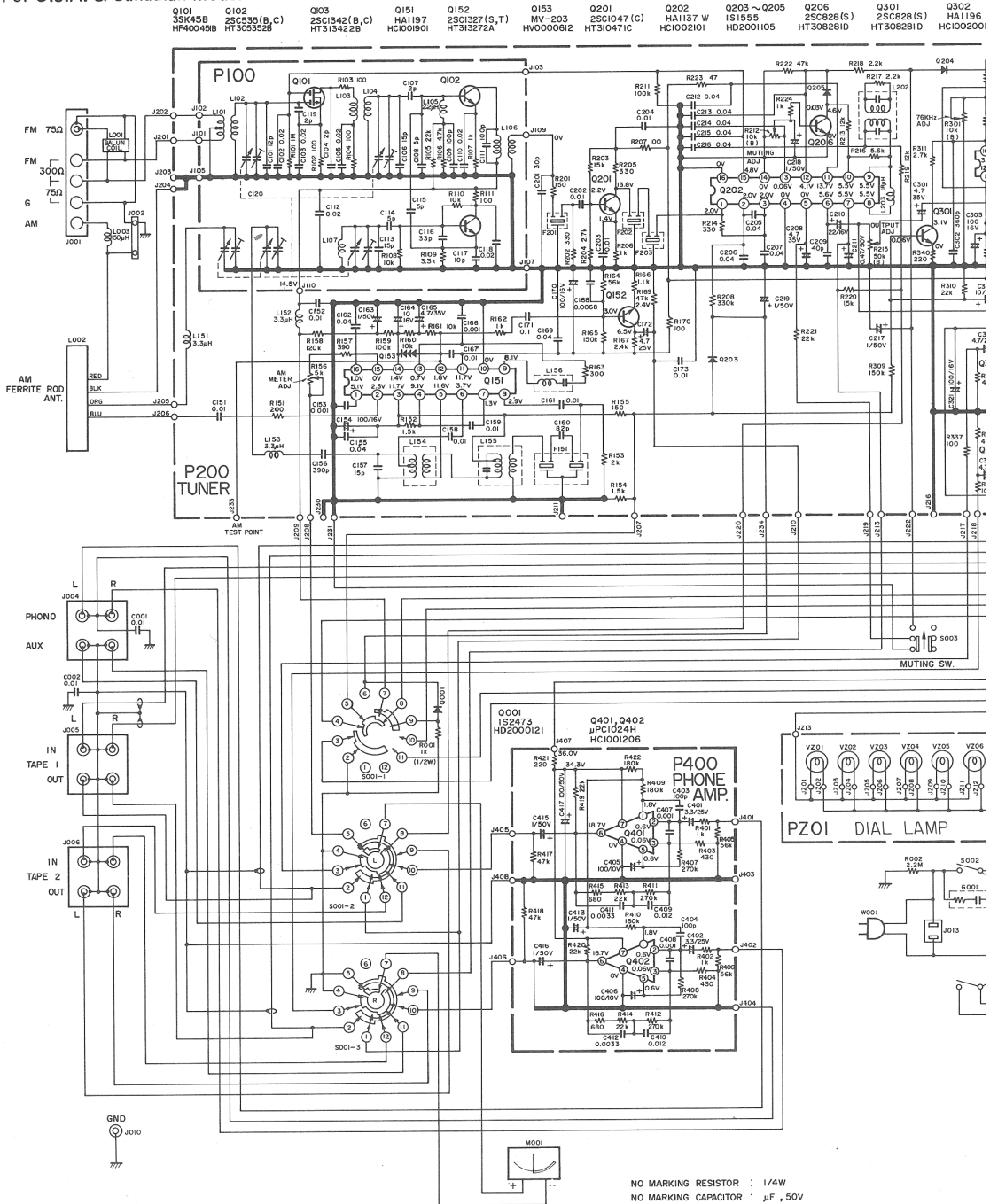

13.2 For European Model

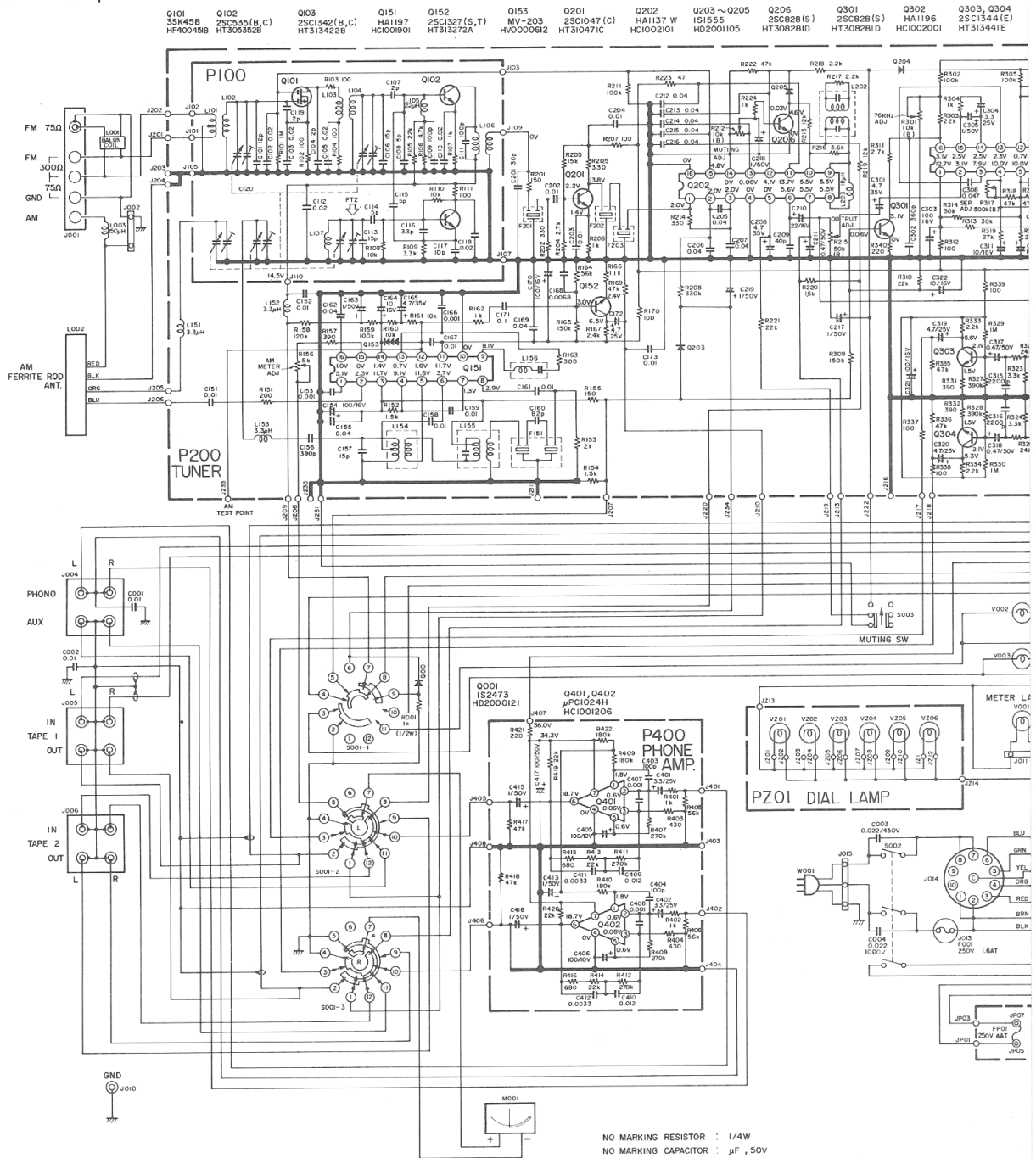

Model 2216B

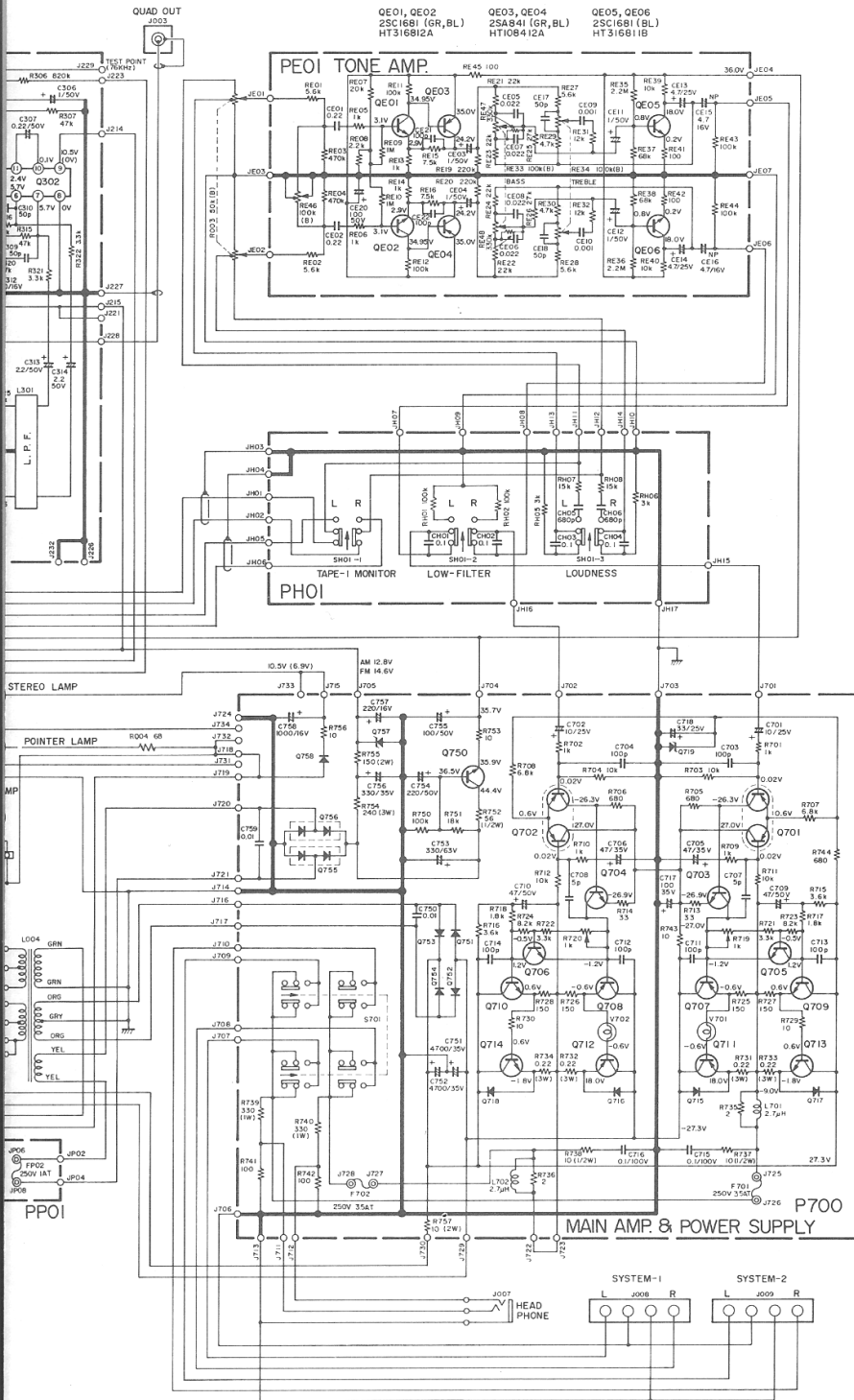

- Q701, Q702 2SA798 (F,G) HT10798 2A
- Q703, Q704 2SC1384 (R,S) HT31384 2C
- Q705, Q706 2SC945 (Q) HT30945 1Q
- Q707, Q708 2SA684 (Q,R) HK1384 19F
- Q709, Q710 2SC1384 (Q,R) HK1384 19F
- Q711, Q712 2SB907 (D,E) HK0507 19A
- Q713, Q714 2SD313 (D,E) HK0507 19A
- Q715~Q718 W06B HD2000501
- Q719 WZ-177 HD3003009
- Q750 2SC1384 (Q,R) HT31384 2B
- Q751~Q754 S3V10 HD2000729
- Q755, Q756 DS-133A HD2000803
- Q757 BZ-140 HD3002109
- Q758 W06B HD2000501

14. EXPLODED MECHANICAL DIAGRAMS

14.1 Cabinet

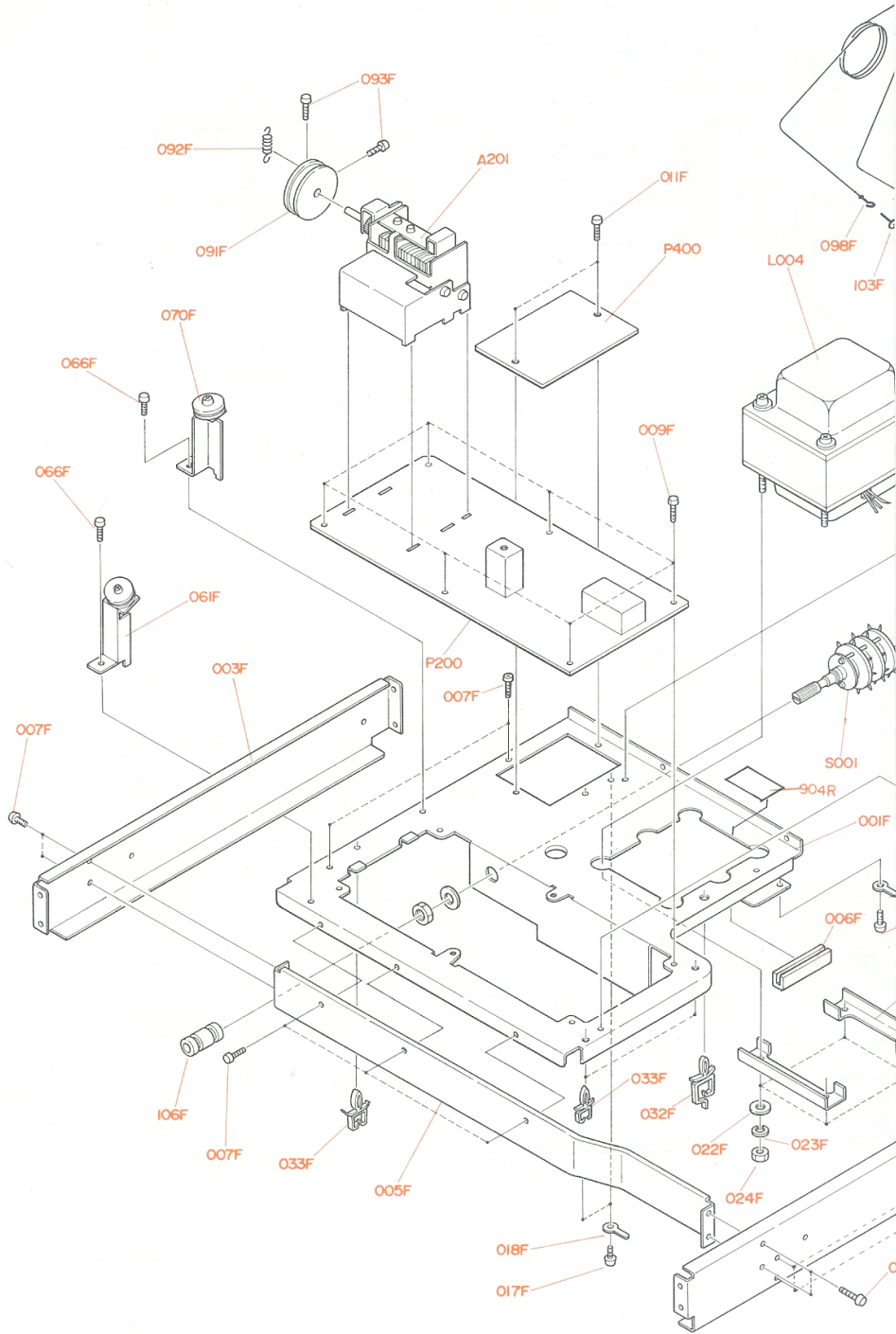

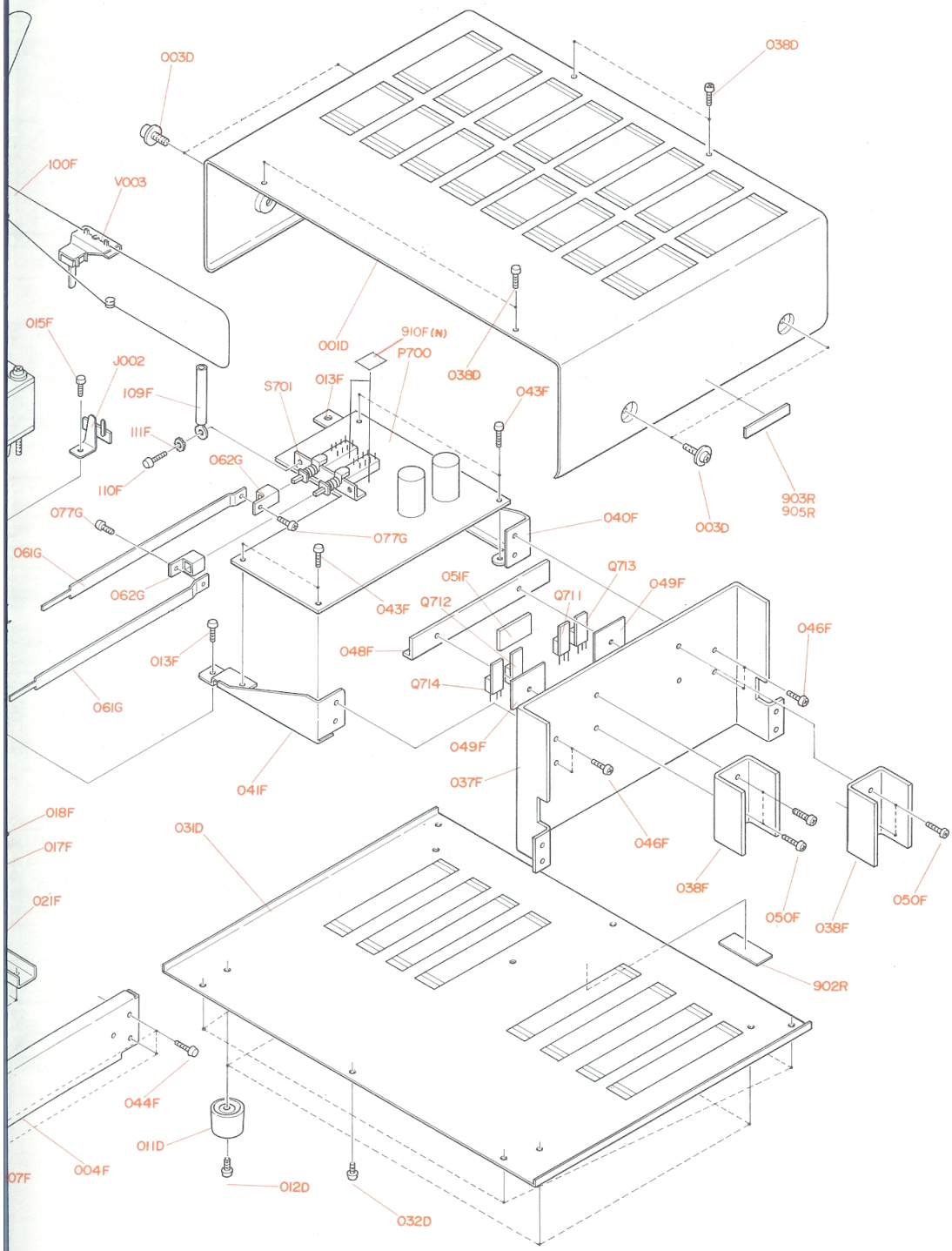

14.2 Chassis

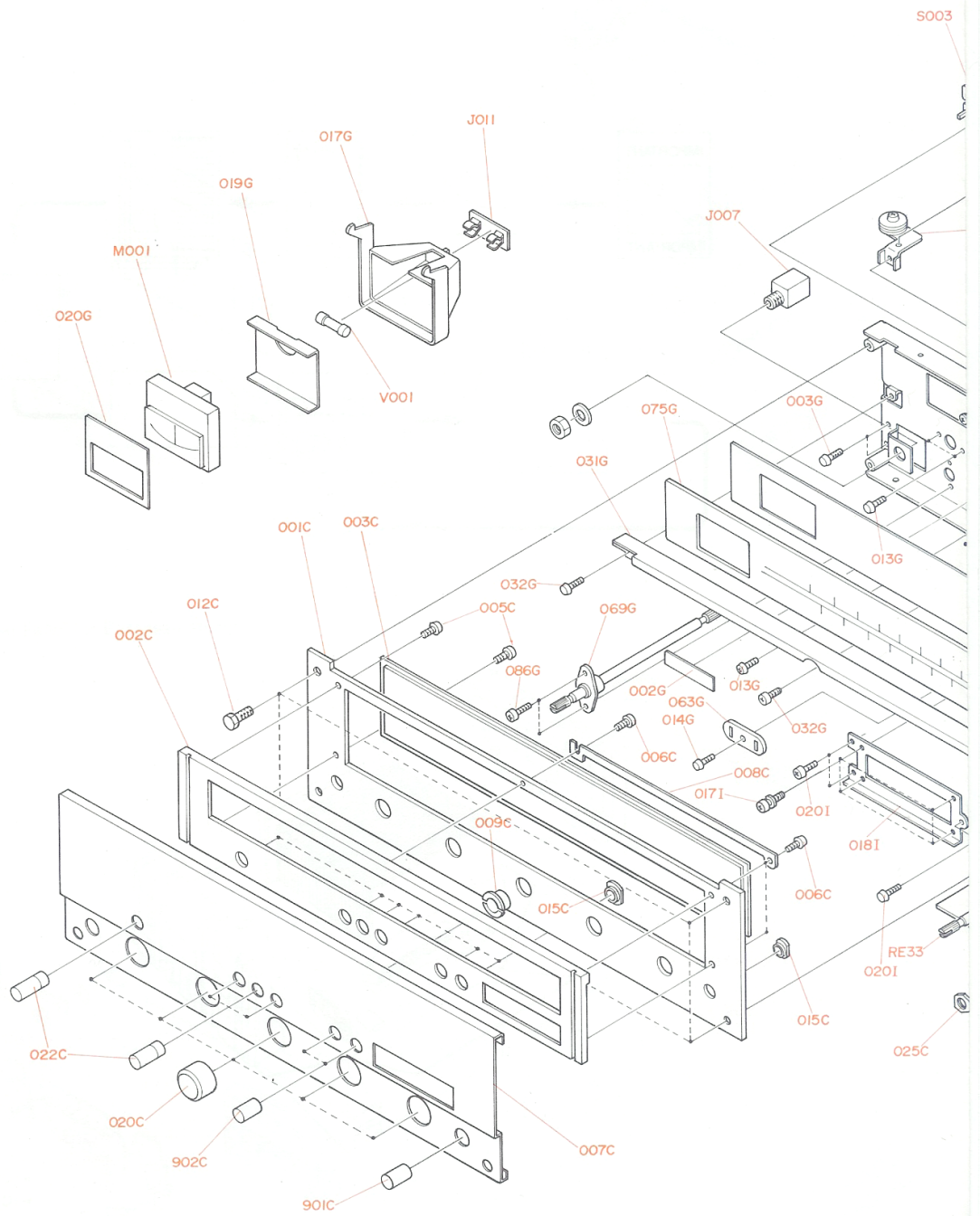

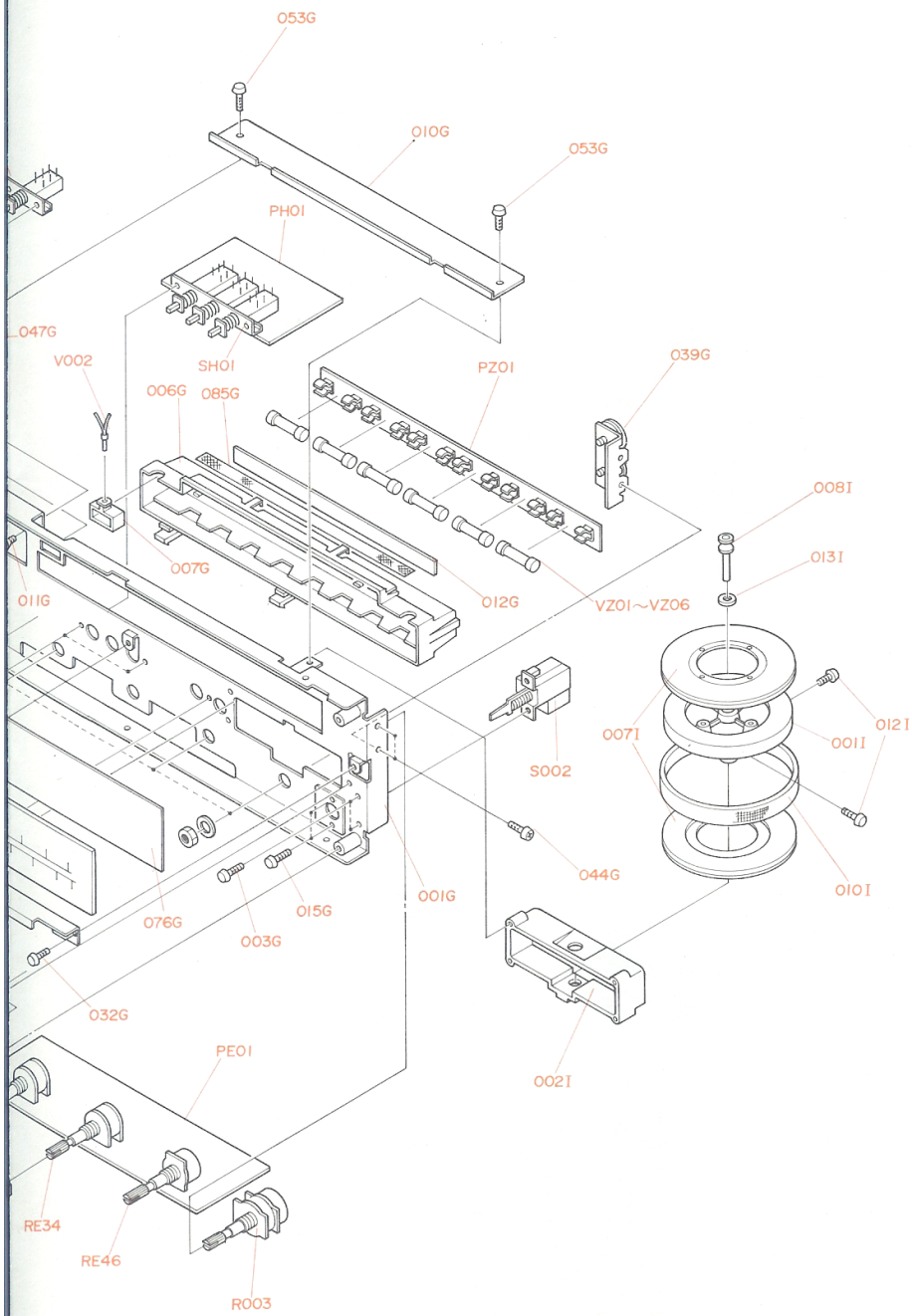

14.3 Rear Panel for U.S.A. & Canadian Model

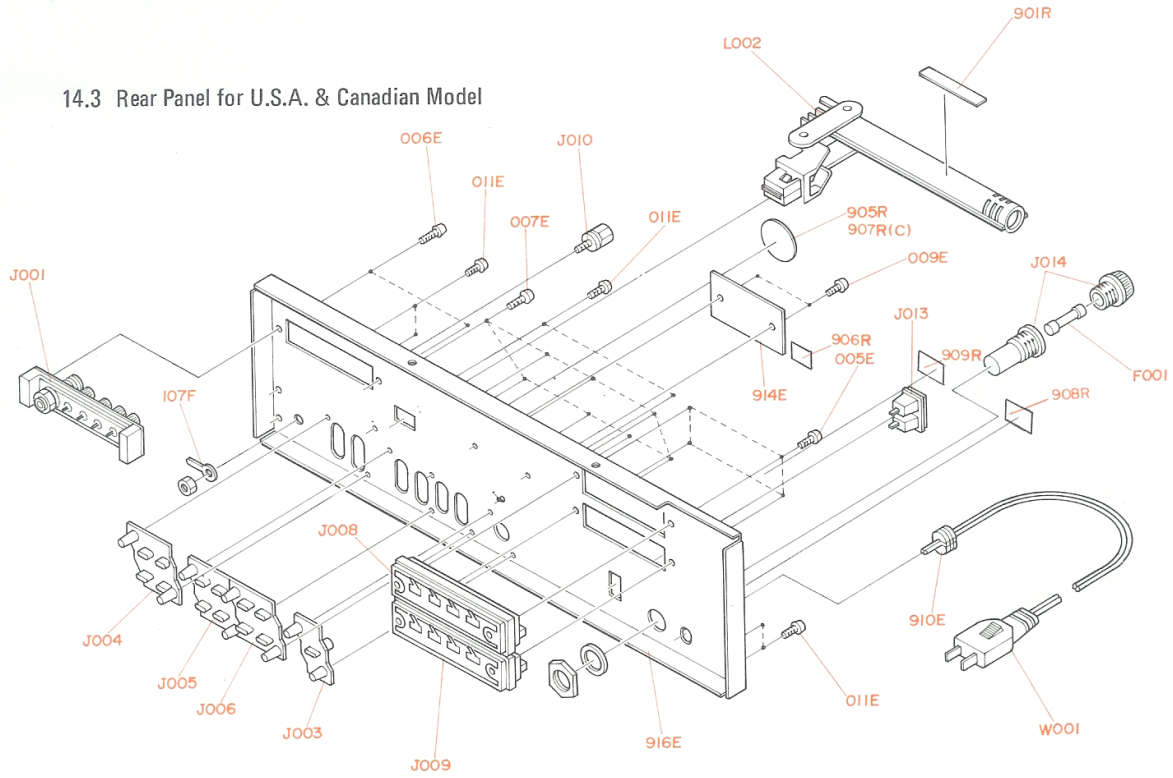

14.4 Rear Panel for European Model

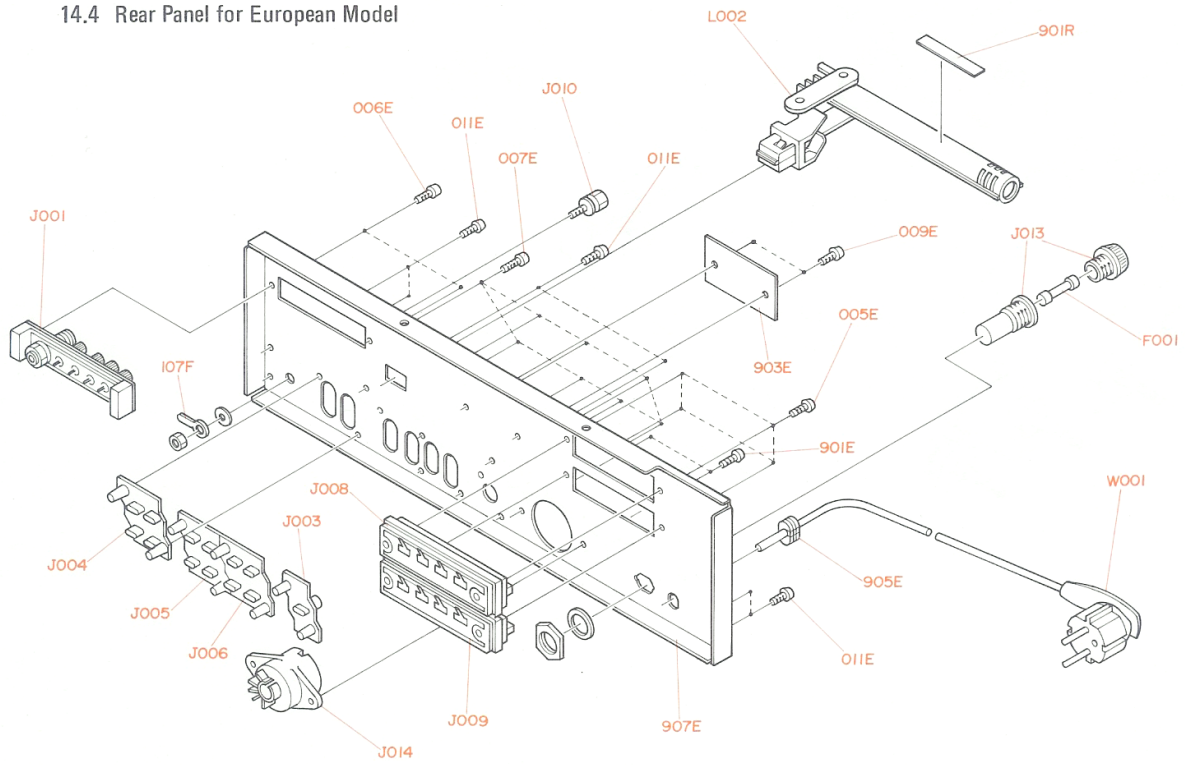

15. PACKING MATERIAL EXPLODED VIEW

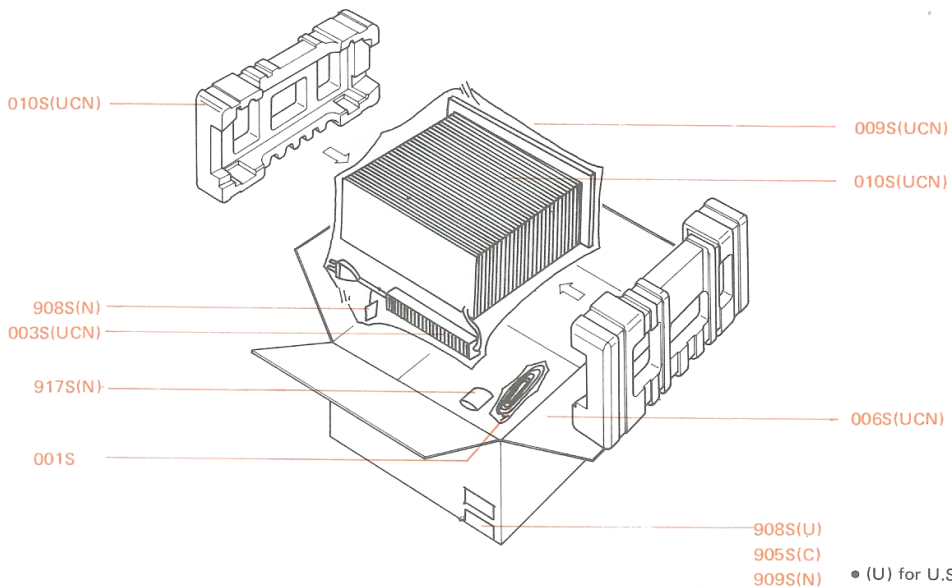
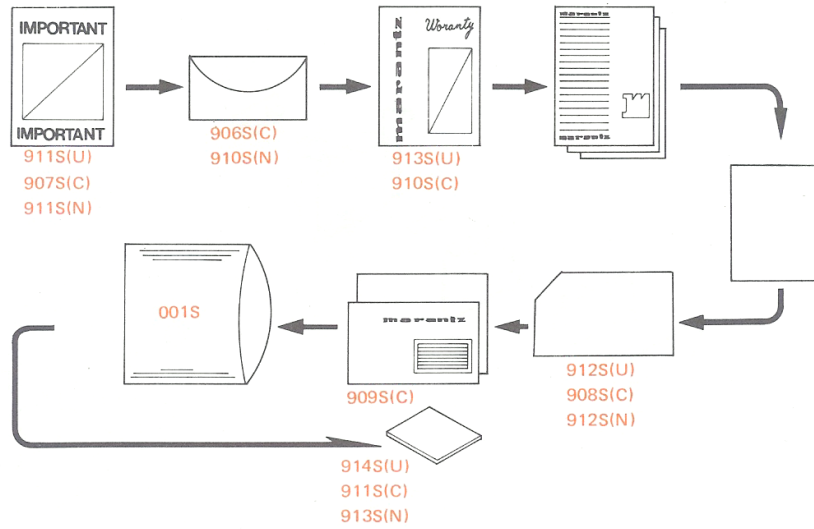

- (U) for U.S.A.
- (C) for Canada
- (E) for Europe

16. PARTS LIST

- (U) for U.S.A.
- (C) for Canada
- (N) for Europe

REF. DESIG.	Q'TY			PART NO.	DESCRIPTION	REF. DESIG.	Q'TY			PART NO.	DESCRIPTION
	U	C	N				U	C	N		
A	1	1	1	2225063400	Front Panel Assembly	003S	1	1	1	2864804010	Sleeve
001C	1	1	1	2225063012	Escutcheon	004F	1	1	1	2225126020	Stay
002C	1	1	1	2225063022	Escutcheon	005E	4	4	4	51280308U0	B.H. Tapped Screw, B3 x 8
003C	1	1	1	2211158110	Window	005F	1	1	1	2225126032	Stay
005C	5	5	5	51100305A9	B.H.M. Screw, B3 x 5	006C	2	2	2	51100306S9	B.H.M. Screw, B3 x 6
007C	1	1	1	2225053012	Cover	006E	2	2	2	51280308U0	B.H. Tapped Screw, B3 x 8
015C	7	7	7	2978259012	Bushing	006F	1	1	1	2225259010	Bushing
B	1	1	1	2219273410	Flywheel Assembly	006G	1	1	1	2215274102	Reflector
0011	1	1	1	2219273010	Flywheel	006S	1	1	1	2225801010	Packing Case
0071	2	2	2	2219063030	Escutcheon	007E	8	8	8	51280308U0	B.H. Tapped Screw, B3 x 8
0101	1	1	1	2215353010	Ring	007F	9	9	9	51280308B0	B.H. Tapped Screw, B3 x 8
0121	2	2	2	51820206B0	P.H.M. Screw, P2 x 6	007G	1	1	1	2211274303	Reflector
C	1	1	1	2219159410	Drum Assembly	007S	2	2	2	2221803010	Partitioner
091F	1	1	1	2219159010	Drum	008C	1	1	1	2213160170	Bracket
092F	1	1	1	71101689L0	Spring	008I	1	1	1	2219112010	Shaft
093F	2	2	2	51064019A9	P.H.M. Screw	009C	1	1	1	2225055012	Collar
D	1	1	1	1202006430	Hook Assembly	009E	2	2	2	51760306B0	OS Tapped Screw, O3 x 6
098F	1	1	1	1202258010	Hook	009F	6	6	6	51280308B0	B.H. Tapped Screw, B3 x 8
100F	2	2	2	72071605A0	String	009S	1	1	1	9014538350	Polyethylene Bag
PE08	2	2	2	2933118020	Spacer	010G	1	1	1	2225051012	Guide
PE12	2	2	2	75061251P0	Jumper	010S	1	1	1	2918107150	Sheet
P208	12	12	12	2933118020	Spacer	011D	4	4	4	2932057010	Leg
P211	9	9	9	75061251P0	Jumper	011E	6	6	6	51280308U0	B.H. Tapped Screw, B3 x 8
P408	2	2	2	2933118020	Spacer	011F	2	2	2	51280308B0	B.H. Tapped Screw, B3 x 8
P707	28	28	28	3444118050	Spacer	011G	2	2	2	51042608A0	F.H.M. Screw, F2.6 x 8
P709	8	8	8	2933118010	Spacer	012C	4	4	4	52017069J0	H. Head Bolt
P711	2	2	2	75061001P0	Jumper	012D	4	4	4	51570410S0	P. Tapped Screw, P4 x 10
P712	3	3	3	75061251P0	Jumper	012G	1	1	1	2225118010	Spacer
P713	1	1	1	75061501P0	Jumper	013F	2	2	2	51280308B0	B.H. Tapped Screw, B3 x 8
P714	2	2	2	75061751P0	Jumper	013G	4	4	4	51100306A9	B.H.M. Screw, B3 x 6
P715	1	1	1	75062001P0	Jumper	013I	1	1	1	59031405G9	Washer
P757	8	8	8	3444118050	Spacer	014G	1	1	1	51280308B0	B.H. Tapped Screw, B3 x 8
P758	6	6	6	2933118020	Spacer	015F	2	2	2	51280308B0	B.H. Tapped Screw, B3 x 8
P759	8	8	8	2933118010	Spacer	015G	2	2	2	51100306A9	B.H.M. Screw, B3 x 6
P761	1	1	1	75061001P0	Jumper	017F	3	3	3	51280308B0	B.H. Tapped Screw, B3 x 8
001D	1	1	1	2225257010	Lid	017G	1	1	1	2225274203	Reflector
001F	1	1	1	2225105013	Chassis	017I	4	4	4	51470306A9	L. Washer Screw, L3 x 6
001G	1	1	1	2225160013	Bracket	018F	3	3	3	62030049W0	Lug
001H	1	1	1	2991103500	Pointer	018I	1	1	1	2205160123	Bracket
001S	1	1	1	9013025010	Polyethylene Bag	019F	1	1	1	62030039W0	Lug
001V	1	1	1	ZA02000070	Ext. Antenna, FM	019G	1	1	1	2213053022	Cover
002G	1	1	1	2991861010	Label	020C	5	5	5	2221154232	Knob
002I	1	1	1	2213104500	Retainer	020F	1	1	1	62030039W0	Lug
003D	4	4	4	51480406S9	F. Washer Screw, F4 x 6	020G	1	1	1	2991107022	Sheet
003F	1	1	1	2225126010	Stay	020I	3	3	3	51280306B0	B.H. Tapped Screw, B3 x 6
003G	4	4	4	51280308B0	B.H. Tapped Screw, B3 x 8	021F	2	2	2	2956160052	Bracket
						022C	4	4	4	2205154030	Knob
						022F	4	4	4	54020401A0	Flat Washer, P
						023F	4	4	4	54040402A0	Spring Washer
						024F	4	4	4	53110403A9	Hexagon Nut
						025C	1	1	1	53118219G0	Hexagon Nut
						031D	1	1	1	2225257022	Lid
						031F	2	2	2	2886005060	Clamper
						031G	1	1	1	2205269013	Protector
						032D	7	7	7	51280408U0	B.H. Tapped Screw, B4 x 8
						032F	1	1	1	2886005020	Clamper
						032G	3	3	3	51280306B0	B.H. Tapped Screw, B3 x 6

- (U) for U.S.A.
- (C) for Canada
- (N) for Europe

REF. DESIG.	Q'TY			PART NO.	DESCRIPTION	REF. DESIG.	Q'TY			PART NO.	DESCRIPTION
	U	C	N				U	C	N		
033F	1	1	1	2886005050	Clamper	905E			1	1455259050	Bushing
037F	1	1	1	2225267012	Heatsink	905R			1	2911861142	Label
038F	2	2	2	2225267020	Heatsink	905R	1			9511101020	Label
039G	1	1	1	2205262510	Pulley	905S			3	9523015120	Serial No. Card
040F	1	1	1	2225160030	Bracket	906F			2	51280314B0	B.H. Tapped Screw, B3 x 14
041F	1	1	1	2225160040	Bracket	906R			1	9510911010	Label
043F	4	4	4	51280308B0	B.H. Tapped Screw, B3 x 8	906S			1	2918813012	Envelope
044F	4	4	4	51280308B0	B.H. Tapped Screw, B3 x 8	907E			1	2225160223	Bracket
044G	2	2	2	51280308B0	B.H. Tapped Screw, B3 x 8	907F			1	2213120010	Insulator
045F	2	2	2	51280308U0	B.H. Tapped Screw, B3 x 8	907S			1	2818851120	Instructions
046F	4	4	4	51280308U0	B.H. Tapped Screw, B3 x 8	908F			2	2970120030	Insulator
047G	1	1	1	2205262502	Pulley	908R			1	2911861012	Label
048F	1	1	1	2956005010	Clamper	908S	3			9522815010	Serial No. Card
050F	2	2	2	51100312S0	B.H.M. Screw, B3 x 12	908S			1	9560000042	Hang Tag
051F	1	1	1	3917118012	Spacer	908S			1	9630000180	Guarantee Card
053G	1	1	1	51280308B0	B.H. Tapped Screw, B3 x 8	909R			1	2911861192	Label
054G	1	1	1	2927160050	Bracket	909S			3	9523015110	Serial No. Card
055G	1	1	1	51570306B0	P. Tapped Screw, P3 x 6	909S			1	9650000050	S. Station Card
056G	1	1	1	2908259010	Bushing	910E	1		1	1455259030	Bushing
061F	1	1	1	2225262500	Pulley	910F			2	2225861020	Label
061G	2	2	2	2225112022	Shaft	910R			1	2911861260	Label
062G	2	2	2	2891271013	Holder	910S			1	2818813010	Envelope
063G	1	1	1	2205259010	Bushing	910S			1	2818854042	Guarantee Card
064G	1	1	1	51280308B0	B.H. Tapped Screw, B3 x 8	911S			1	2577851020	Instructions
066F	2	2	2	51280308B0	B.H. Tapped Screw, B3 x 8	911S			1	2818851120	Instructions
069G	1	1	1	2225112502	Shaft	911S			1	2818854140	Guarantee Card
070F	1	1	1	2205262530	Pulley	912S			1	2577854012	Guarantee Card
075G	1	1	1	2225302012	Dial	912S			1	9630000180	Guarantee Card
076G	1	1	1	2225107012	Sheet	913S			1	2818851140	Instructions
077G	2	2	2	51100306A9	B.H.M. Screw, B3 x 6	913S			1	2818854023	Guarantee Card
085G	1	1	1	2219202050	Net	914E			1	2225265012	Indicator
103F	1	1	1	56382540G0	Eyelet	914E			1	2225265022	Indicator
106F	1	1	1	2963125010	Joint	914S			1	2818851040	Instructions
107F	1	1	1	62040029W0	Lug	915S			1	2225851030	Instructions
109F	1	1	1	2871005010	Clamper	916E			1	2225160210	Bracket
110F	1	1	1	51100306A9	B.H.M. Screw, B3 x 6	916S			1	2225851310	Instructions
111F	1	1	1	54050300R0	T.L. Washer, OR	917S			1	2225851010	Instructions
135F	1	1	1	2991109010	Shield	917S			1	2225851030	Instructions
136F	1	1	1	2991053112	Cover	917S			1	2731821010	Silicagel
901C	1	1		2963154022	Knob	918S			1	2225851020	Instructions
901C			2	2970154012	Knob	918S			1	2886851100	Instructions
901E			2	51100308S9	B.H.M. Screw, B3 x 8	CE01	1		1	DF17224050	Film Cap., 0.22μF ±20% 50V
901F			1	2854160030	Bracket	CE02	1		1	DF17224050	Film Cap., 0.22μF ±20% 50V
901R	1		1	2506265060	Indicator	CE03	1		1	EE10505010	Electrolytic Cap., 1μF ±20% 50V
901R		1		2911861170	Label	CE04	1		1	EE10505010	Electrolytic Cap., 1μF ±20% 50V
902C			1	2218154020	Knob	CE05	1		1	DF16223050	Film Cap., 0.022μF ±10% 50V
902C	2	2		2970154012	Knob	CE06	1		1	DF16223050	Film Cap., 0.022μF ±10% 50V
902F			2	51100306A0	B.H.M. Screw, B3 x 6	CE07	1		1	DF16223050	Film Cap., 0.022μF ±10% 50V
902R	1		1	2578861010	Label	CE08	1		1	DF16223050	Film Cap., 0.022μF ±10% 50V
902R		1		2911861112	Label	CE09	1		1	DF16102050	Film Cap., 0.001μF ±10% 50V
903E			1	2225265030	Indicator	CE10	1		1	DF16102050	Film Cap., 0.001μF ±10% 50V
903F			2	51280308B0	B.H. Tapped Screw, B3 x 8	CE11	1		1	EE10505010	Electrolytic Cap., 1μF ±20% 50V
903R	1		1	2932861010	Label	CE12	1		1	EE10505010	Electrolytic Cap., 1μF ±20% 50V
903R		1		9510601020	Label	CE13	1		1	EE47502510	Electrolytic Cap., 4.7μF ±20% 25V
904R		1		2225861010	Label	CE14	1		1	EE47502510	Electrolytic Cap., 4.7μF ±20% 25V
904R		1		2882861020	Label	CE15	1		1	EQ47501610	Electrolytic Cap., 4.7μF ±30% 16V
904R	1			9510911020	Label						

- (U) for U.S.A.
- (C) for Canada
- (N) for Europe

REF. DESIG.	Q'TY			PART NO.	DESCRIPTION	REF. DESIG.	Q'TY			PART NO.	DESCRIPTION
	U	C	N				U	C	N		
CE16	1	1	1	EQ47501610	Electrolytic Cap., 4.7 μ F \pm 30% 16V	RE41	1	1	1	RT05101140	Resistor, 100 Ω \pm 5% $\frac{1}{4}$ W
CE17	1	1	1	DD16500010	Ceramic Cap., 50pF \pm 10% 50V	RE42	1	1	1	RT05101140	Resistor, 100 Ω \pm 5% $\frac{1}{4}$ W
CE18	1	1	1	DD16500010	Ceramic Cap., 50pF \pm 10% 50V	RE43	1	1	1	RT05104140	Resistor, 100k Ω \pm 5% $\frac{1}{4}$ W
CE20	1	1	1	EA10705090	Electrolytic Cap., 100 μ F \pm 30% 50V	RE44	1	1	1	RT05104140	Resistor, 100k Ω \pm 5% $\frac{1}{4}$ W
CE21	1	1	1	DD16101010	Ceramic Cap., 100pF \pm 10% 50V	RE45	1	1	1	RT05101140	Resistor, 100 Ω \pm 5% $\frac{1}{4}$ W
CE22	1	1	1	DD16101010	Ceramic Cap., 100pF \pm 10% 50V	RE46	1	1	1	RK01040160	Variable Resistor, 100k Ω (B)
JE01						CH01	1	1	1	DF16273050	Film Cap., 0.027 μ F \pm 10% 50V
JE07	7	7	7	YP10001130	Plug	CH02	1	1	1	DF16273050	Film Cap., 0.027 μ F \pm 10% 50V
						CH03	1	1	1	DF16104010	Film Cap., 0.1 μ F \pm 10% 50V
						CH04	1	1	1	DF16104010	Film Cap., 0.1 μ F \pm 10% 50V
						CH05	1	1	1	DK16681010	Ceramic Cap., 680pF \pm 10% 50V
PE01	1	1	1	YK22250220	PE01 TONE AMP. P.W. Board	CH06	1	1	1	DK16681010	Ceramic Cap., 680pF \pm 10% 50V
	1	1	1	ZZ22250220	P.W. Board Assembly	JH01					
						JH07	17	17	17	YP10001130	Plug
QE01	1	1	1	HT316812A0	Transistor, 2SC1681 (GR, BL)	JH17					
QE02	1	1	1	HT316812A0	Transistor, 2SC1681 (GR, BL)						
QE03	1	1	1	HT108412A0	Transistor, 2SA841 (GR, BL)						
QE04	1	1	1	HT108412A0	Transistor, 2SA841 (GR, BL)	PH01	1	1	1	YK22250410	PH01 FILTER BOARD P.W. Board
QE05	1	1	1	HT316811B0	Transistor, 2SC1681 (BL)		1	1	1	ZZ22250410	P.W. Board Assembly
QE06	1	1	1	HT316811B0	Transistor, 2SC1681 (BL)						
RE01	1	1	1	RT05562140	Resistor, 5.6k Ω \pm 5% $\frac{1}{4}$ W	RH01	1	1	1	RT05102140	Resistor, 1k Ω \pm 5% $\frac{1}{4}$ W
RE02	1	1	1	RT05562140	Resistor, 5.6k Ω \pm 5% $\frac{1}{4}$ W	RH02	1	1	1	RT05102140	Resistor, 1k Ω \pm 5% $\frac{1}{4}$ W
RE03	1	1	1	RT05474140	Resistor, 470k Ω \pm 5% $\frac{1}{4}$ W	RH03	1	1	1	RT05225140	Resistor, 2.2M Ω \pm 5% $\frac{1}{4}$ W
RE04	1	1	1	RT05474140	Resistor, 470k Ω \pm 5% $\frac{1}{4}$ W	RH04	1	1	1	RT05225140	Resistor, 2.2M Ω \pm 5% $\frac{1}{4}$ W
						RH05	1	1	1	RT05302140	Resistor, 3k Ω \pm 5% $\frac{1}{4}$ W
RE05	1	1	1	RT05102140	Resistor, 1k Ω \pm 5% $\frac{1}{4}$ W	RH06	1	1	1	RT05302140	Resistor, 3k Ω \pm 5% $\frac{1}{4}$ W
RE06	1	1	1	RT05102140	Resistor, 1k Ω \pm 5% $\frac{1}{4}$ W	RH07	1	1	1	RT05153140	Resistor, 15k Ω \pm 5% $\frac{1}{4}$ W
RE07	1	1	1	RT05203140	Resistor, 20k Ω \pm 5% $\frac{1}{4}$ W	RH08	1	1	1	RT05153140	Resistor, 15k Ω \pm 5% $\frac{1}{4}$ W
RE08	1	1	1	RT05222140	Resistor, 2.2k Ω \pm 5% $\frac{1}{4}$ W	SH01	1	1	1	SP02030020	Pushswitch
RE09	1	1	1	RT05105140	Resistor, 1M Ω \pm 5% $\frac{1}{4}$ W	FP01	1	1	1	FS10400800	Fuse, 4AT (SEMKO)
RE10	1	1	1	RT05105140	Resistor, 1M Ω \pm 5% $\frac{1}{4}$ W	FP02	1	1	1	FS10100800	Fuse, 1AT (SEMKO)
RE11	1	1	1	RT05104140	Resistor, 100k Ω \pm 5% $\frac{1}{4}$ W	JP01					
RE12	1	1	1	RT05104140	Resistor, 100k Ω \pm 5% $\frac{1}{4}$ W	JP02	4	4	4	YP10001130	Plug
RE13	1	1	1	RT05102140	Resistor, 1k Ω \pm 5% $\frac{1}{4}$ W	JP04					
RE14	1	1	1	RT05102140	Resistor, 1k Ω \pm 5% $\frac{1}{4}$ W	JP05					
						JP08	4	4	4	YJ08000200	Jack, Fuse Holder
RE15	1	1	1	RT05752140	Resistor, 7.5k Ω \pm 5% $\frac{1}{4}$ W						
RE16	1	1	1	RT05752140	Resistor, 7.5k Ω \pm 5% $\frac{1}{4}$ W						
RE19	1	1	1	RT05224140	Resistor, 220k Ω \pm 5% $\frac{1}{4}$ W						
RE20	1	1	1	RT05224140	Resistor, 220k Ω \pm 5% $\frac{1}{4}$ W						
RE21	1	1	1	RT05223140	Resistor, 22k Ω \pm 5% $\frac{1}{4}$ W	PP01	1	1	1	YF22250020	PP01 FUSE BOARD P.W. Board
RE22	1	1	1	RT05223140	Resistor, 22k Ω \pm 5% $\frac{1}{4}$ W		1	1	1	ZZ22250020	P.W. Board Assembly
RE23	1	1	1	RT05223140	Resistor, 22k Ω \pm 5% $\frac{1}{4}$ W						
RE24	1	1	1	RT05223140	Resistor, 22k Ω \pm 5% $\frac{1}{4}$ W	JZ01					
RE25	1	1	1	RT05273140	Resistor, 27k Ω \pm 5% $\frac{1}{4}$ W		12	12	12	YJ08000170	Jack, Lamp Holder
RE26	1	1	1	RT05273140	Resistor, 27k Ω \pm 5% $\frac{1}{4}$ W	JZ12					
						JZ13	1	1	1	YP10001130	Plug
RE27	1	1	1	RT05562140	Resistor, 5.6k Ω \pm 5% $\frac{1}{4}$ W	JZ14	1	1	1	YP10001130	Plug
RE28	1	1	1	RT05562140	Resistor, 5.6k Ω \pm 5% $\frac{1}{4}$ W						
RE29	1	1	1	RT05472140	Resistor, 4.7k Ω \pm 5% $\frac{1}{4}$ W						
RE30	1	1	1	RT05472140	Resistor, 4.7k Ω \pm 5% $\frac{1}{4}$ W	PZ01	1	1	1	YF22250010	PZ01 DIAL LAMP BOARD P.W. Board
RE31	1	1	1	RT05123140	Resistor, 12k Ω \pm 5% $\frac{1}{4}$ W		1	1	1	ZZ22250010	P.W. Board Assembly
RE32	1	1	1	RT05123140	Resistor, 12k Ω \pm 5% $\frac{1}{4}$ W						
RE33	1	1	1	RM01040150	Variable Resistor, 100k Ω (B)	VZ01	1	1	1	IN10080070	Lamp, 8V 200mA
RE34	1	1	1	RM01040150	Variable Resistor, 100k Ω (B)	VZ02	1	1	1	IN10080070	Lamp, 8V 200mA
RE35	1	1	1	RT05225140	Resistor, 2.2M Ω \pm 5% $\frac{1}{4}$ W	VZ03	1	1	1	IN10080070	Lamp, 8V 200mA
RE36	1	1	1	RT05225140	Resistor, 2.2M Ω \pm 5% $\frac{1}{4}$ W	VZ04	1	1	1	IN10080070	Lamp, 8V 200mA
						VZ05	1	1	1	IN10080070	Lamp, 8V 200mA
RE37	1	1	1	RT05683140	Resistor, 68k Ω \pm 5% $\frac{1}{4}$ W	VZ06	1	1	1	IN10080070	Lamp, 8V 200mA
RE38	1	1	1	RT05683140	Resistor, 68k Ω \pm 5% $\frac{1}{4}$ W	C001	1	1	1	DK18103010	Ceramic Cap., 0.01 μ F \pm 20% 50V
RE39	1	1	1	RT05103140	Resistor, 10k Ω \pm 5% $\frac{1}{4}$ W	C002	1	1	1	DK18103010	Ceramic Cap., 0.01 μ F \pm 20% 50V
RE40	1	1	1	RT05103140	Resistor, 10k Ω \pm 5% $\frac{1}{4}$ W						

- (U) for U.S.A.
- (C) for Canada
- (N) for Europe

REF. DESIG.	Q'TY			PART NO.	DESCRIPTION
	U	C	N		
C003			1	DO07223510	Oil-Paper Cap., 0.022μF 450V
C004			1	DF17223800	Film Cap., 0.022μF 1000V
F001			1	FS10160800	Fuse, SEMKO 1.6AT
F001	1	1		FS10200060	Fuse, UL 250V 2A
G001	1			BF10400030	Cap.Comp., Spark Killer (UL)
G001	1			BF10400050	Cap.Comp., Spark Killer (CSA)
J001	1	1		BY04050010	Terminal, 4P 75Ω Ant.
J001	1	1		BY04050020	Terminal, 4P 75Ω Ant.
J002	1	1	1	YL01020080	Terminal, 2P
J003	1	1	1	YT02010130	Terminal, 1P Quad. Out
J004	1	1	1	YT02040140	Terminal, 4P Phono,Aux In
J005	1	1	1	YT02040140	Terminal, 4P Tape 1
J006	1	1	1	YT02040140	Terminal, 4P Tape 2
J007	1	1	1	YJ01001080	Jack, Headphones
J008	1	1	1	YT03040160	Terminal, SP. System-1
J009	1	1	1	YT03040160	Terminal, SP. System-2
J010	1	1	1	YT01010050	Terminal, Ground
J011	1	1	1	YJ08000250	Jack, Meter Lamp Holder
J013	1	1	1	YJ04000560	Jack, AC Outlet
J013	1	1	1	YJ08000220	Jack, Fuse Holder
J014			1	BY03110010	Plug, Voltage Selector
J014	1			YJ08000120	Jack, Fuse Holder
J014			1	YJ08000230	Jack, Fuse Holder
J015	1	1	1	YL09030010	Terminal, 3P
L001	1	1	1	LB30075260	Balun Coil
L002	1	1	1	LF11200520	Ant. Coil, AM
L003	1	1	1	LC11540040	Choke Coil, 150μH
L004	1	1	1	TS18603050	Power Transformer
L004	1	1	1	TS18603060	Power Transformer
M001	1	1	1	IM11055070	D.C. Meter, FM Tun., AM Sig. Meter
R001	1	1	1	GF05102120	Resistor, 1kΩ ±5% ½W
R002	1	1	1	RC10225120	Resistor, 2.2MΩ ±10% ½W
R003	1	1	1	RM05030740	Variable Resistor, 50kΩ (B) Vol. ¼
S001	1	1	1	SR06050170	Rotary Switch, Selector
S002	1	1	1	SP02010270	Pushswitch, Power (UL)
S002	1	1	1	SP04010250	Pushswitch, Power (SEMKO)
S003	1	1	1	SP02010090	Pushswitch, FM Muting
V001	1	1	1	IN10080430	Lamp, Meter 8V 300MA
V002	1	1	1	IN10080340	Lamp, Stereo 8V 60MA
W001	1	1	1	YC01900030	A.C.Power Cord
W001	1	1	1	YC02400220	A.C.Power Cord
C101	1	1	1	DD16120020	Ceramic Cap., 12pF ±10%
C102	1	1	1	DK18203030	Ceramic Cap., 0.02μF
C103	1	1	1	DK18203030	Ceramic Cap., 0.02μF
C104	1	1	1	DD11020010	Ceramic Cap., 2pF
C105	1	1	1	DK18203030	Ceramic Cap., 0.02μF
C106	1	1	1	DD16150040	Ceramic Cap., 15pF ±10%
C107	1	1	1	DD11020010	Ceramic Cap., 2pF
C108	1	1	1	DD12050010	Ceramic Cap., 5pF
C109	1	1	1	DD16101010	Ceramic Cap., 100pF ±10%
C110	1	1	1	DK18203030	Ceramic Cap., 0.02μF
C111	1	1	1	DD16101010	Ceramic Cap., 100pF ±10%
C112	1	1	1	DK18203030	Ceramic Cap., 0.02μF
C113	1	1	1	DD15150020	Ceramic Cap., 15pF ±5%
C114	1	1	1	DD10050030	Ceramic Cap., 5pF
C115	1	1	1	DD12050010	Ceramic Cap., 5pF
C116	1	1	1	DD16330020	Ceramic Cap., 33pF ±10%

REF. DESIG.	Q'TY			PART NO.	DESCRIPTION
	U	C	N		
C117	1	1	1	DD12100060	Ceramic Cap., 10pF
C118	1	1	1	DK18203030	Ceramic Cap., 0.02μF
C119	1	1	1	DD11020010	Ceramic Cap., 2pF
C120	1	1	1	CA32400080	Variable Cap.,
C121	1	1	1	CT14200010	Trimming Cap.,
C151	1	1	1	DK17103010	Ceramic Cap., 0.01μF ±20%
C152	1	1	1	DK17103010	Ceramic Cap., 0.01μF ±20%
C153	1	1	1	DK17102010	Ceramic Cap., 0.001μF ±20%
C154	1	1	1	EA10701690	Electrolytic Cap., 100μF 16V
C155	1	1	1	DK18403020	Ceramic Cap., 0.04μF
C156	1	1	1	DF65391010	Film Cap., 390pF
C157	1	1	1	DD16150010	Ceramic Cap., 15pF ±10%
C158	1	1	1	DK18103010	Ceramic Cap., 0.01μF
C159	1	1	1	DK17103010	Ceramic Cap., 0.01μF ±20%
C160	1	1	1	DD16820010	Ceramic Cap., 82pF ±10%
C161	1	1	1	DK17103010	Ceramic Cap., 0.01μF ±20%
C162	1	1	1	DK18403020	Ceramic Cap., 0.04μF
C163	1	1	1	EA10505090	Electrolytic Cap., 1μF 50V
C164	1	1	1	EA10601690	Electrolytic Cap., 10μF 16V
C165	1	1	1	EA47503590	Electrolytic Cap., 4.7μF 35V
C166	1	1	1	DK17102010	Ceramic Cap., 0.001μF ±20%
C167	1	1	1	DK18103010	Ceramic Cap., 0.01μF
C168	1	1	1	DK16682010	Ceramic Cap., 0.0068μF ±10%
C169	1	1	1	DK18403020	Ceramic Cap., 0.04μF
C170	1	1	1	EA10701690	Electrolytic Cap., 100μF 16V
C171	1	1	1	DF16104010	Film Cap., 0.1μF ±10%
C172	1	1	1	EE47502510	Electrolytic Cap., 4.7μF 25V
F151	1	1	1	FF10045160	Ceramic Filter, AM 455kHz
J101	1	1	1	YP10001510	Plug
J102	1	1	1	YP10001510	Plug
J103	1	1	1	YP10001510	Plug
J105	1	1	1	YP10001510	Plug
J107	1	1	1	YP10001510	Plug
J109	1	1	1	YP10001510	Plug
J110	1	1	1	YP10001510	Plug
J111	1	1	1	YP10001510	Plug
L105	1	1	1	LC12220010	Choke Coil
L106	1	1	1	LI10239010	I.F.T.
L151	1	1	1	LC13320020	Choke Coil, 3.3μH
L152	1	1	1	LC13320020	Choke Coil, 3.3μF
L153	1	1	1	LC13320020	Choke Coil, 3.3μH
L154	1	1	1	LO10010480	Osc. Coil, AM
L155	1	1	1	LI10015010	I.F.T., AM
L156	1	1	1	LI10015060	I.F.T., AM
P100 FM FRONT END BOARD					
P100	1	1	1	YD29910010	P.W. Board
A201	1	1	1	AV01202060	FM Front End Assembly
Q101	1	1	1	HF400451B0	F.E.T., 3SK45 B
Q102	1	1	1	HT305352B0	Transistor, 2SC535 (B, C)
Q103	1	1	1	HT313422B0	Transistor, 2SC1342 (B, C)
Q151	1	1	1	HC10019010	IC, HA1197
Q152	1	1	1	HT313272A0	Transistor, 2SC1327 (S, T)
Q153	1	1	1	HV00006120	Varistor, MV-203
R101	1	1	1	GD05105140	Resistor, 1MΩ ±5% ¼W
R102	1	1	1	GD05101140	Resistor, 100Ω ±5% ¼W
R103	1	1	1	GD05101140	Resistor, 100Ω ±5% ¼W

- (U) for U.S.A.
- (C) for Canada
- (N) for Europe

REF. DESIG.	Q'TY			PART NO.	DESCRIPTION	REF. DESIG.	Q'TY			PART NO.	DESCRIPTION
	U	C	N				U	C	N		
R104	1	1	1	GD05101140	Resistor, 100Ω ±5% ¼W	J217					
R105	1	1	1	GD05223140	Resistor, 22kΩ ±5% ¼W	7	7	7	YP10001130	Plug	
R106	1	1	1	GD05472140	Resistor, 4.7kΩ ±5% ¼W	J223					
R107	1	1	1	GD05102140	Resistor, 1kΩ ±5% ¼W	J227	1	1	1	YP10001130	Plug
R108	1	1	1	GD05103140	Resistor, 10kΩ ±5% ¼W	J228	1	1	1	YP10001130	Plug
R109	1	1	1	GD05332140	Resistor, 3.3kΩ ±5% ¼W	J229	1	1	1	YP10001130	Plug, Test Point (76kHz)
R110	1	1	1	GD05103140	Resistor, 10kΩ ±5% ¼W	J231	1	1	1	YP10001130	Plug
R111	1	1	1	GD05101140	Resistor, 100Ω ±5% ¼W	J233	1	1	1	YP10001130	Plug
R151	1	1	1	RT05201140	Resistor, 200Ω ±5% ¼W	L202	1	1	1	LI 14019010	I.F.T., FM
R152	1	1	1	RT05152140	Resistor, 1.5kΩ ±5% ¼W	L203	1	1	1	LC11830010	Choke Coil, 18μH
R153	1	1	1	RT05202140	Resistor, 2kΩ ±5% ¼W						P200 TUNER BOARD
R154	1	1	1	RT05152140	Resistor, 1.5kΩ ±5% ¼W	P200	1	1	1	YD22042012	P.W. Board
R155	1	1	1	RT05151140	Resistor, 150Ω ±5% ¼W	1	1			ZZ22252010	P.W. Board Assembly
R156	1	1	1	RA05020200	Trimming Resistor, 5kΩ	1				ZZ22258010	P.W. Board Assembly
R157	1	1	1	RT05391140	Resistor, 390Ω ±5% ¼W						
R158	1	1	1	RT05124140	Resistor, 120kΩ ±5% ¼W	Q201	1	1	1	HT310471C0	Transistor, 2SC1047 C
R159	1	1	1	RT05104140	Resistor, 100kΩ ±5% ¼W	Q202	1	1	1	HC10021010	IC, HA1137W
R160	1	1	1	RT05103140	Resistor, 10kΩ ±5% ¼W	Q203	1	1	1	HD20011050	Diode, 1S1555
R161	1	1	1	RT05103140	Resistor, 10kΩ ±5% ¼W	Q204	1	1	1	HD20011050	Diode, 1S1555
R162	1	1	1	RT05102140	Resistor, 1kΩ ±5% ¼W	Q205	1	1	1	HD20011050	Diode, 1S1555
R163	1	1	1	RT05301140	Resistor, 300Ω ±5% ¼W	Q206	1	1	1	HT308281D0	Transistor, 2SC828 S
R164	1	1	1	RT05473140	Resistor, 47kΩ ±5% ¼W	R201	1	1	1	RT05151140	Resistor, 150Ω ±5% ¼W
R165	1	1	1	RT05104140	Resistor, 100kΩ ±5% ¼W	R202	1	1	1	RT05331140	Resistor, 330Ω ±5% ¼W
R166	1	1	1	RT05152140	Resistor, 1.5kΩ ±5% ¼W	R203	1	1	1	RT05153140	Resistor, 15kΩ ±5% ¼W
R167	1	1	1	RT05242140	Resistor, 2.4kΩ ±5% ¼W	R204	1	1	1	RT05202140	Resistor, 2kΩ ±5% ¼W
R169	1	1	1	RT05473140	Resistor, 47kΩ ±5% ¼W	R205	1	1	1	RT05331140	Resistor, 330Ω ±5% ¼W
R170	1	1	1	RT05101140	Resistor, 100Ω ±5% ¼W	R206	1	1	1	RT05102140	Resistor, 1kΩ ±5% ¼W
A201	1	1	1	AV01202060	V.H.F. Tuner, FM Front End	R207	1	1	1	RT05101140	Resistor, 100Ω ±5% ¼W
C201	1	1	1	DD15300010	Ceramic Cap., 30pF ±5%	R208	1	1	1	RT05334140	Resistor, 330kΩ ±5% ¼W
C202	1	1	1	DK17103010	Ceramic Cap., 0.01μF ±20%	R211	1	1	1	RT05104140	Resistor, 100kΩ ±5% ¼W
C203	1	1	1	DK17103010	Ceramic Cap., 0.01μF ±20%	R212	1	1	1	RA01030250	Trimming Resistor, 10kΩ B
C204	1	1	1	DK17103010	Ceramic Cap., 0.01μF ±20%	R213	1	1	1	RT05123140	Resistor, 12kΩ ±5% ¼W
C205	1	1	1	DK18403020	Ceramic Cap., 0.04μF	R214	1	1	1	RT05331140	Resistor, 330Ω ±5% ¼W
C206	1	1	1	DK18403020	Ceramic Cap., 0.04μF	R215	1	1	1	RA05030120	Trimming Resistor, 50kΩ B
C207	1	1	1	DK18403020	Ceramic Cap., 0.04μF	R216	1	1	1	RT05562140	Resistor, 5.6kΩ ±5% ¼W
C208	1	1	1	EA47503590	Electrolytic Cap., 4.7μF 35V	R217	1	1	1	RT05222140	Resistor, 2.2kΩ ±5% ¼W
C209	1	1	1	DD15400040	Ceramic Cap., 40pF ±5%	R218	1	1	1	RT05222140	Resistor, 2.2kΩ ±5% ¼W
C210	1	1	1	EA22601690	Electrolytic Cap., 22μF 16V	R219	1	1	1	RT05123140	Resistor, 12kΩ ±5% ¼W
C211	1	1	1	EA47405010	Electrolytic Cap., 0.47μF 50V	R220	1	1	1	RT05152140	Resistor, 15kΩ ±5% ¼W
C212	1	1	1	DK18403010	Ceramic Cap., 0.04μF	R221	1	1	1	RT05223140	Resistor, 22kΩ ±5% ¼W
C213	1	1	1	DK18403010	Ceramic Cap., 0.04μF	R222	1	1	1	RT05473140	Resistor, 47kΩ ±5% ¼W
C214	1	1	1	DK18403010	Ceramic Cap., 0.04μF	R223	1	1	1	RT05470140	Resistor, 47Ω ±5% ¼W
C215	1	1	1	DK18403010	Ceramic Cap., 0.04μF	R224	1	1	1	RT05102140	Resistor, 1kΩ ±5% ¼W
C216	1	1	1	DK18403010	Ceramic Cap., 0.04μF	C301	1	1	1	EA47503590	Electrolytic Cap., 4.7μF 35V
C217	1	1	1	EA10505090	Electrolytic Cap., 1μF 50V	C302	1	1	1	DF65361500	Film Cap., 360pF ±5%
C218	1	1	1	EA10505090	Electrolytic Cap., 1μF 50V	C303	1	1	1	EA10701690	Electrolytic Cap., 100μF 16V
F201	1	1	1	FF11070050	Ceramic Filter, FM 10.7MHz	C304	1	1	1	EE33502510	Electrolytic Cap., 3.3μF 25V
F202	1	1	1	FF11070050	Ceramic Filter, FM 10.7MHz	C305	1	1	1	EE10505010	Electrolytic Cap., 1μF 50V
F203	1	1	1	FF11070050	Ceramic Filter, FM 10.7MHz	C306	1	1	1	EA10505090	Electrolytic Cap., 1μF 50V
J201	1	1	1	YP10001130	Plug	C307	1	1	1	EQ22405010	Electrolytic Cap., 0.22μF 50V
J202	1	1	1	YP10001130	Plug	C308	1	1	1	DF17473010	Film Cap., 0.047μF ±20%
J204						C309	1	1	1	DD15500050	Ceramic Cap., 50pF ±5%
7	7	7	7	YP10001130	Plug	C310	1	1	1	DD15500050	Ceramic Cap., 50pF ±5%
J210						C311	1	1	1	EA10601690	Electrolytic Cap., 10μF 16V
J213	1	1	1	YP10001130	Plug	C312	1	1	1	EA10601690	Electrolytic Cap., 10μF 16V
J214	1	1	1	YP10001130	Plug	C313	1	1	1	EA22505090	Electrolytic Cap., 2.2μF 50V
J215	1	1	1	YP10001130	Plug	C314	1	1	1	EA22505090	Electrolytic Cap., 2.2μF 50V

- (U) for U.S.A.
- (C) for Canada
- (N) for Europe

REF. DESIG.	Q'TY			PART NO.	DESCRIPTION	REF. DESIG.	Q'TY			PART NO.	DESCRIPTION
	U	C	N				U	C	N		
C315			1	DF15222050	Film Cap., 2200pF ±5% 50V	C404	1	1	1	DD16101010	Ceramic Cap., 100pF ±10% 50V
C315	1	1		DF15332050	Film Cap., 3300pF ±5% 50V	C405	1	1	1	EA10701090	Electrolytic Cap., 100μF ^{+5%} / _{-10%} 10V
C316			1	DF15222050	Film Cap., 2200pF ±5% 50V	C406	1	1	1	EA10701090	Electrolytic Cap., 100μF ^{+5%} / _{-10%} 10V
C316	1	1		DF15332050	Film Cap., 3300pF ±5% 50V	C407	1	1	1	DK17102010	Ceramic Cap., 0.001μF ±20% 50V
C317	1	1	1	EA47405010	Electrolytic Cap., 0.47μF 50V	C408	1	1	1	DK17102010	Ceramic Cap., 0.001μF ±20% 50V
C318	1	1	1	EA47405010	Electrolytic Cap., 0.47μF 50V	C409	1	1	1	DF15123010	Film Cap., 0.012μF ±5% 50V
C319	1	1	1	EE47502510	Electrolytic Cap., 4.7μF 25V	C410	1	1	1	DF15123010	Film Cap., 0.012μF ±5% 50V
C320	1	1	1	EE47502510	Electrolytic Cap., 4.7μF 25V	C411	1	1	1	DF15332010	Film Cap., 0.0033μF ±5% 50V
C321	1	1	1	EA10701690	Electrolytic Cap., 100μF 16V	C412	1	1	1	DF15332010	Film Cap., 0.0033μF ±5% 50V
C322	1	1	1	EE10601610	Electrolytic Cap., 10μF 16V	C413	1	1	1	EA10505090	Electrolytic Cap., 1μF ^{+7%} / _{-16%} 50V
L301	1	1	1	LS35025010	M.P.X. Coil	C415	1	1	1	EE10505040	Electrolytic Cap., 1μF ±20% 50V
Q301	1	1	1	HT308281D0	Transistor, 2SC828 S	C416	1	1	1	EE10505040	Electrolytic Cap., 1μF ±20% 50V
Q302	1	1	1	HC10020010	IC, HA1196	C417	1	1	1	EA10705090	Electrolytic Cap., 100μF ^{+5%} / _{-10%} 50V
Q303	1	1	1	HT313441E0	Transistor, 2SC1344 E	J401	1	1	1	YP10001130	Plug
Q304	1	1	1	HT313441E0	Transistor, 2SC1344 E	J402	1	1	1	YP10001130	Plug
R301	1	1	1	RA01030310	Trimming Resistor, 10kΩ B	J404					
R302	1	1	1	RT05104140	Resistor, 100kΩ ±5% ¼W	J408	5	5	5	YP10001130	Plug
R303	1	1	1	RT05223140	Resistor, 22kΩ ±5% ¼W						
R304	1	1	1	RT05102140	Resistor, 1kΩ ±5% ¼W						
R305	1	1	1	RT05104140	Resistor, 100kΩ ±5% ¼W						
R306	1	1	1	RT05824140	Resistor, 820kΩ ±5% ¼W						
R307	1	1	1	RT05473140	Resistor, 47kΩ ±5% ¼W						
R309	1	1	1	RT05154140	Resistor, 150kΩ ±5% ¼W						
R310	1	1	1	RT05223140	Resistor, 22kΩ ±5% ¼W						
R311	1	1	1	RT05272140	Resistor, 2.7kΩ ±5% ¼W						
R312	1	1	1	RT05101140	Resistor, 100Ω ±5% ¼W						
R313	1	1	1	RT05303140	Resistor, 30kΩ ±5% ¼W						
R314	1	1	1	RT05303140	Resistor, 30kΩ ±5% ¼W						
R315	1	1	1	RT05473140	Resistor, 47kΩ ±5% ¼W						
R316	1	1	1	RT05473140	Resistor, 47kΩ ±5% ¼W						
R317	1	1	1	RA05040080	Trimming Resistor, 500kΩ B						
R318	1	1	1	RT05473140	Resistor, 47kΩ ±5% ¼W						
R319	1	1	1	RT05273140	Resistor, 27kΩ ±5% ¼W						
R320	1	1	1	RT05273140	Resistor, 27kΩ ±5% ¼W						
R321	1	1	1	RT05332140	Resistor, 3.3kΩ ±5% ¼W						
R322	1	1	1	RT05332140	Resistor, 3.3kΩ ±5% ¼W						
R323	1	1	1	RT05332140	Resistor, 3.3kΩ ±5% ¼W						
R324	1	1	1	RT05332140	Resistor, 3.3kΩ ±5% ¼W						
R325	1	1	1	RT05243140	Resistor, 24kΩ ±5% ¼W						
R326	1	1	1	RT05243140	Resistor, 24kΩ ±5% ¼W						
R327	1	1	1	RT05394140	Resistor, 390kΩ ±5% ¼W						
R328	1	1	1	RT05394140	Resistor, 390kΩ ±5% ¼W						
R329	1	1	1	RT05105140	Resistor, 1MΩ ±5% ¼W						
R330	1	1	1	RT05105140	Resistor, 1MΩ ±5% ¼W						
R331	1	1	1	RT05391140	Resistor, 390Ω ±5% ¼W						
R332	1	1	1	RT05391140	Resistor, 390Ω ±5% ¼W						
R333	1	1	1	RT05222140	Resistor, 2.2kΩ ±5% ¼W						
R334	1	1	1	RT05222140	Resistor, 2.2kΩ ±5% ¼W						
R335	1	1	1	RT05473140	Resistor, 47kΩ ±5% ¼W						
R336	1	1	1	RT05473140	Resistor, 47kΩ ±5% ¼W						
R337	1	1	1	RT05101140	Resistor, 100Ω ±5% ¼W						
R338	1	1	1	RT05101140	Resistor, 100Ω ±5% ¼W						
R339	1	1	1	RT05101140	Resistor, 100Ω ±5% ¼W						
R340	1	1	1	RT05201140	Resistor, 200Ω ±5% ¼W						
C401	1	1	1	EV33502560	Electrolytic Cap., 3.3μF ±20% 25V	C701	1	1	1	EE10602540	Electrolytic Cap., 10μF ±20% 25V
C402	1	1	1	EV33502560	Electrolytic Cap., 3.3μF ±20% 25V	C702	1	1	1	EE10602540	Electrolytic Cap., 10μF ±20% 25V
C403	1	1	1	DD16101010	Ceramic Cap., 100pF ±10% 50V	C703	1	1	1	DD16101010	Ceramic Cap., 100pF ±10% 25V
						C704	1	1	1	DD16101010	Ceramic Cap., 100pF ±10% 25V
						C705	1	1	1	EE47603550	Electrolytic Cap., 47μF ±20% 35V
						C706	1	1	1	EE47603550	Electrolytic Cap., 47μF ±20% 35V
						C707	1	1	1	DD11050500	Ceramic Cap., 5pF ±0.25pF 500V
						C708	1	1	1	DD11050500	Ceramic Cap., 5pF ±0.25pF 500V
						C709	1	1	1	EA47605090	Electrolytic Cap., 47μF ^{+5%} / _{-10%} 50V
						C710	1	1	1	EA47605090	Electrolytic Cap., 47μF ^{+5%} / _{-10%} 50V
						C711	1	1	1	DK16101500	Ceramic Cap., 100pF ±10% 500V

- (U) for U.S.A.
- (C) for Canada
- (N) for Europe

REF. DESIG.	Q'TY			PART NO.	DESCRIPTION	REF. DESIG.	Q'TY			PART NO.	DESCRIPTION		
	U	C	N				U	C	N				
C712	1	1	1	DK16101500	Ceramic Cap., 100pF ±10% 500V	Q751	1	1	1	HD20007290	Diode, S3V10		
C713	1	1	1	DK16101500	Ceramic Cap., 100pF ±10% 500V	Q752	1	1	1	HD20007290	Diode, S3V10		
C714	1	1	1	DK16101500	Ceramic Cap., 100pF ±10% 500V	Q753	1	1	1	HD20007290	Diode, S3V10		
C715	1	1	1	DF16104050	Film Cap., 0.1μF ±10% 100V	Q754	1	1	1	HD20007290	Diode, S3V10		
C716	1	1	1	DF16104050	Film Cap., 0.1μF ±10% 100V	Q755	1	1	1	HD20008030	Diode, DS-133A		
C717	1	1	1	EA10703590	Electrolytic Cap., 100μF $\pm\frac{50}{10}\%$ 35V	Q756	1	1	1	HD20008030	Diode, DS-133A		
C718	1	1	1	EA33602590	Electrolytic Cap., 33μF $\pm\frac{50}{10}\%$ 25V	Q757	1	1	1	HD30021090	Zener, BZ-140		
C750	1	1	1	DK18103510	Ceramic Cap., 0.01μF ±20% 500V	Q758	1	1	1	HD20005010	Diode, W06B		
C751	1	1	1	EB47803520	Electrolytic Cap., 4700μF $\pm\frac{50}{10}\%$ 35V	R701	1	1	1	RT05102140	Resistor, 1kΩ ±5% ¼W		
C752	1	1	1	EB47803520	Electrolytic Cap., 4700μF $\pm\frac{50}{10}\%$ 35V	R702	1	1	1	RT05102140	Resistor, 1kΩ ±5% ¼W		
C753	1	1	1	EA33706310	Electrolytic Cap., 330μF $\pm\frac{50}{10}\%$ 63V	R703	1	1	1	RT05103140	Resistor, 10kΩ ±5% ¼W		
C754	1	1	1	EA22705090	Electrolytic Cap., 220μF $\pm\frac{50}{10}\%$ 50V	R704	1	1	1	RT05103140	Resistor, 10kΩ ±5% ¼W		
C755	1	1	1	EA10705090	Electrolytic Cap., 100μF $\pm\frac{50}{10}\%$ 50V	R705	1	1	1	RT05681140	Resistor, 680Ω ±5% ¼W		
C756	1	1	1	EA33703590	Electrolytic Cap., 330μF $\pm\frac{50}{10}\%$ 35V	R706	1	1	1	RT05681140	Resistor, 680Ω ±5% ¼W		
C757	1	1	1	EA22701690	Electrolytic Cap., 220μF $\pm\frac{50}{10}\%$ 16V	R707	1	1	1	RT05682140	Resistor, 6.8kΩ ±5% ¼W		
C758	1	1	1	EA10801690	Electrolytic Cap., 1000μF $\pm\frac{50}{10}\%$ 16V	R708	1	1	1	RT05682140	Resistor, 6.8kΩ ±5% ¼W		
C759	1	1	1	DK18103510	Ceramic Cap., 0.01μF ±20% 500V	R709	1	1	1	RT05102140	Resistor, 1kΩ ±5% ¼W		
F701	1	1	1	FS10350010	Fuse, SP. 3.5A 250V (UL)	R710	1	1	1	RT05102140	Resistor, 1kΩ ±5% ¼W		
F701	1	1	1	FS10350800	Fuse, SP. 3.5AT 250V (SEMKO)	R711	1	1	1	RT05103140	Resistor, 10kΩ ±5% ¼W		
F702	1	1	1	FS10350010	Fuse, SP. 3.5A 250V (UL)	R712	1	1	1	RT05103140	Resistor, 10kΩ ±5% ¼W		
F702			1	FS10350800	Fuse, SP. 3.5AT 250V (SEMKO)	R713	1	1	1	GF05330140	Resistor, 33Ω ±5% ¼W		
J701			24	24	24	YP10001130	Plug	R714	1	1	1	GF05330140	Resistor, 33Ω ±5% ¼W
J724								R715	1	1	1	RT05362140	Resistor, 3.6kΩ ±5% ¼W
J725			4	4	4	YJ08000210	Jack,	R716	1	1	1	RT05362140	Resistor, 3.6kΩ ±5% ¼W
J728								R717	1	1	1	RT05182140	Resistor, 1.8kΩ ±5% ¼W
J729								R718	1	1	1	RT05182140	Resistor, 1.8kΩ ±5% ¼W
J734			6	6	6	YP10001130	Plug	R719	1	1	1	RA01020150	Trimming Resistor, 1kΩ (B)
L701	1	1	1	LC22720010	Choke Coil, 2.7μH	R720	1	1	1	RA01020150	Trimming Resistor, 1kΩ (B)		
L702	1	1	1	LC22720010	Choke Coil, 2.7μH	R721	1	1	1	RT05332140	Resistor, 3.3kΩ ±5% ¼W		
								R722	1	1	1	RT05332140	Resistor, 3.3kΩ ±5% ¼W
								R723	1	1	1	RT05822140	Resistor, 8.2kΩ ±5% ¼W
								R724	1	1	1	RT05822140	Resistor, 8.2kΩ ±5% ¼W
								R725	1	1	1	GF05151140	Resistor, 150Ω ±5% ¼W
								R726	1	1	1	GF05151140	Resistor, 150Ω ±5% ¼W
								R727	1	1	1	GF05151140	Resistor, 150Ω ±5% ¼W
								R728	1	1	1	GF05151140	Resistor, 150Ω ±5% ¼W
								R729	1	1	1	GF05100140	Resistor, 10Ω ±5% ¼W
								R730	1	1	1	GF05100140	Resistor, 10Ω ±5% ¼W
								R731	1	1	1	GX10222030	Resistor, 0.22Ω ±10% 3W
								R732	1	1	1	GX10222030	Resistor, 0.22Ω ±10% 3W
								R733	1	1	1	GX10222030	Resistor, 0.22Ω ±10% 3W
								R734	1	1	1	GX10222030	Resistor, 0.22Ω ±10% 3W
								R735	1	1	1	RC10020120	Resistor, 2Ω ±10% ¼W
								R736	1	1	1	RC10020120	Resistor, 2Ω ±10% ¼W
								R737	1	1	1	RC10100120	Resistor, 10Ω ±10% ¼W
								R738	1	1	1	RC10100120	Resistor, 10Ω ±10% ¼W
								R739	1	1	1	GJ05331010	Resistor, 330Ω ±5% 1W
								R740	1	1	1	GJ05331010	Resistor, 330Ω ±5% 1W
								R741	1	1	1	GF05101140	Resistor, 100Ω ±5% ¼W
								R742	1	1	1	GF05101140	Resistor, 100Ω ±5% ¼W
								R743	1	1	1	GF05100140	Resistor, 10Ω ±5% ¼W
								R744	1	1	1	GF05681140	Resistor, 680Ω ±5% ¼W
								R750	1	1	1	RT05104140	Resistor, 100kΩ ±5% ¼W
								R751	1	1	1	RT05183140	Resistor, 18kΩ ±5% ¼W
								R752	1	1	1	GF05560120	Resistor, 56Ω ±5% ¼W
								R753	1	1	1	GF05100140	Resistor, 10Ω ±5% ¼W
								R754	1	1	1	GJ05241030	Resistor, 240Ω ±5% 3W
								R755	1	1	1	GJ05151020	Resistor, 150Ω ±5% 2W
								R756	1	1	1	GF05100140	Resistor, 10Ω ±5% ¼W
								R757	1	1	1	GJ05100010	Resistor, 10Ω ±5% 1W
								S701	1	1	1	SP04020200	Pushswitch,
								V701	1	1	1	IN10060390	Lamp, 6V
								V702	1	1	1	IN10060390	Lamp, 6V

17. TECHNICAL SPECIFICATIONS

FOR U.S.A. MODEL ONLY

AMPLIFIER SECTION:

RATED POWER OUTPUT, MINIMUM CONTINUOUS AVERAGE POWER PER CHANNEL, BOTH CHANNELS DRIVEN	16 W
POWER BAND	20 Hz to 20 kHz
TOTAL HARMONIC DISTORTION	0.15%
LOAD IMPEDANCE	8 OHMS
RATED POWER OUTPUT, MINIMUM CONTINUOUS AVERAGE POWER PER CHANNEL, BOTH CHANNELS DRIVEN	20 W
POWER BAND	40 Hz to 20 kHz
TOTAL HARMONIC DISTORTION	0.3%
LOAD IMPEDANCE	4 OHMS

I.M. Distortion

(I.H.F. method, 60 Hz and 7 kHz mixed 4:1 at rated power output)	
at 8 ohm load impedance	0.15%
at 4 ohm load impedance	0.3%
Damping Factor (at 40 Hz)	40

PREAMPLIFIER SECTION:

Phono	
Input Overload at 1 kHz	100 mV
Equivalent Input Noise	2.5 μ V
Dynamic Range	
(Dynamic Range is the ratio of input overload to equivalent input noise)	92 dB
Input Sensitivity	2.5 mV
Input Impedance	47k ohms
Input Capacitance	100 pF
Frequency Response, RIAA 20 Hz to 20 kHz	± 1.0 dB
Signal-to-Noise Ratio	
(at rated output and 7.75 mV input)	74 dB
High Level (Aux and Tape)	
Input Sensitivity	180 mV
Input Impedance	20k ohms
Frequency Response	
(includes power amp)	20 Hz to 60 kHz ± 1.5 dB
Signal-to-Noise Ratio	
(ref. to rated output and 775 mV input)	85 dB
Output Levels	
Tape Out (ref. 7.75 mV at Phono inputs)	525 mV
Output Impedance	
Tape Out	600 ohms

FM TUNER SECTION:

Sensitivity	
IHF Usable	10.8 dBf (1.9 μ V)
IHF 50 dB Quieting (Mono)	16.3 dBf (3.2 μ V)
(Stereo)	37.3 dBf (40 μ V)
Quieting Slope (Mono)	
RF Input for 30 dB Quieting	9.3 dBf (1.6 μ V)
Quieting at:	
20 dBf (5.5 μ V)	55 dB
25 dBf (10 μ V)	60 dB
40 dBf (55 μ V)	70 dB
65 dBf (1000 μ V)	75 dB
Quieting Slope (Stereo)	
Quieting at:	
30 dBf (17 μ V)	42 dB
40 dBf (55 μ V)	53 dB
50 dBf (173 μ V)	58 dB
65 dBf (1000 μ V)	65 dB

Distortion (Mono) at 65 dBf (1000 μ V)

100 Hz	0.3%
1000 Hz	0.2%
6000 Hz	0.35%

Distortion (Stereo) at 65 dBf (1000 μ V)

100 Hz	0.5%
1000 Hz	0.4%
6000 Hz	0.55%

Distortion (Mono and Stereo)

at 50 dB Quieting, 1000 Hz	0.6%
----------------------------	------

Hum and Noise

at 65 dBf (1000 μ V)	
Mono	70 dB

Frequency Response

30 Hz to 15 kHz	
Mono	+0.2 dB, -1.5 dB
Stereo	± 1.5 dB

Capture Ratio at 65 dBf (1000 μ V)

Alternate Channel Selectivity	70 dB
-------------------------------	-------

Spurious Response Rejection

Image Response Rejection	80 dB
--------------------------	-------

I.F. Rejection (Balanced)

	55 dB
--	-------

A.M. Suppression

	90 dB
--	-------

Stereo Separation

100 Hz	40 dB
--------	-------

1000 Hz	45 dB
---------	-------

10 kHz	40 dB
--------	-------

Subcarrier Rejection	60 dB
----------------------	-------

AM TUNER SECTION:

IHF Usable Sensitivity	15 μ V
------------------------	------------

Distortion (THD), 30% Modulation	0.5%
----------------------------------	------

Signal-to-Noise Ratio	50 dB
-----------------------	-------

Alternate Channel Selectivity	40 dB
-------------------------------	-------

Image Rejection	45 dB
-----------------	-------

Spurious Response Rejection	60 dB
-----------------------------	-------

I.F. Rejection	40 dB
----------------	-------

GENERAL:

Power Requirements	120V AC, 60 Hz
--------------------	----------------

Power Consumption at rated output, both channels operating	97 W
--	------

Idling Power (Volume Control at zero)	27 W
---------------------------------------	------

Dimensions:

Panel Width	440 mm (17-5/16 inches)
-------------	-------------------------

Panel Height	137 mm (5-3/8 inches)
--------------	-----------------------

Depth	293 mm (11-7/16 inches)
-------	-------------------------

Weight:

Unit alone	9 kg (19.8 lbs)
------------	-----------------

Packed for Shipment	10.5 kg (23.1 lbs)
---------------------	--------------------

Model 2216B

FOR EUROPEAN MODEL ONLY

AUDIO SECTION

POWER OUTPUT AT 1% DISTORTION	33 W
RATED POWER OUTPUT, 1 kHz	22 W
TOTAL HARMONIC DISTORTION AT RATED POWER OUTPUT, 1 kHz	0.3%
I.M. DISTORTION AT RATED POWER OUTPUT (I.H.F. METHOD, 300 Hz AND 10 kHz MIXED 4:1 AT RATED POWER OUTPUT)	0.3%
POWER BANDWIDTH, 1/2 RATED POWER OUTPUT	8 Hz ~ 30 kHz
LOAD IMPEDANCE	4 OHMS
POWER OUTPUT AT 1% DISTORTION	27 W
RATED POWER OUTPUT, 1 kHz	18 W
TOTAL HARMONIC DISTORTION AT RATED POWER OUTPUT, 1 kHz	0.15%
I.M. DISTORTION AT RATED POWER OUTPUT (I.H.F. METHOD, 300 Hz AND 10 kHz MIXED 4:1 AT RATED POWER OUTPUT)	0.3%
POWER BANDWIDTH, 1/2 RATED POWER OUTPUT	8 Hz ~ 30 kHz
LOAD IMPEDANCE	8 OHMS

Damping Factor, SP Output	
40 Hz	40
1 kHz	40
12.5 kHz	30
Frequency Response	
Phono ±2 dB	20 Hz ~ 20 kHz
Aux ±1.5 dB	15 Hz ~ 35 kHz
Signal-to-Noise Ratio, 1 kHz	
Phono	50 dB
Aux	50 dB
Input Sensitivity, 1 kHz (Rated Input Voltage)	
Phono	2.7 mV
Aux	180 mV
Input Impedance, 1 kHz	
Phono	47k ohms
Aux	20k ohms
Phono Equivalent Input Noise	2.5 µV
Phono Dynamic Range	90 dB
Phono Input Capacitance	100 pF
Channel Balance	
Phono 0 ~ -40 dB	2.5 dB
Aux 40 Hz ~ 16 kHz	2.0 dB
Interchannel Crosstalk	
Phono 1 kHz	35 dB
250 Hz ~ 10 kHz	30 dB
Aux 1 kHz	43 dB
250 Hz ~ 10 kHz	30 dB
Tape 1 kHz	43 dB
250 Hz ~ 10 kHz	30 dB
Intersource Crosstalk, Worst Point	
1 kHz	43 dB
250 Hz ~ 10 kHz	30 dB
Output Voltage, 1 kHz	
Tape Out	0.18 V
Output Impedance, 1 kHz	
Tape Out	120 ohms
Overload Margin, 1 kHz	
Phono	30 dB
Aux	40 dB
Power Consumption	
Idling	27 W
Rated Power, 1 kHz	100 W
FM TUNER SECTION:	
Frequency Range	87.5 ~ 108 MHz
Usable Sensitivity 40 kHz Deviation, 98 MHz	
Mono S/N 26 dB	1.6 µV
Stereo S/N 46 dB	47 µV
Alternate Channel Selectivity 98 MHz, ±300 kHz	50 dB
Image Response Rejection, 98 MHz	60 dB
IF Rejection, 98 MHz	80 dB
Spurious Response Rejection, 98 MHz	80 dB
AM Suppression, 98 MHz	50 dB
Signal-to-Noise Ratio at 98 MHz	
Un-weighted Mono	65 dB

Weighted Stereo	58 dB
Mono	68 dB
Stereo	62 dB
Pilot Signal & Subcarrier Rejection	
19 kHz	60 dB
38 kHz	65 dB
Total Harmonic Distortion at 98 MHz	
Mono	0.2%
Stereo	0.4%
Frequency Response	
30 Hz ~ 15 kHz	+0.2 dB, -2.0 dB
Separation	
250 Hz ~ 6.3 kHz	40 dB
6.3 kHz ~ 12.5 kHz	35 dB
Channel Balance	0.5 dB
Output Voltage, 1 kHz	565 mV
Output Impedance, 1 kHz	2.3k ohms
Acceptable Load Impedance, 1 kHz	47k ohms
Antenna Terminals	
Balanced	300 ohms
Unbalanced	75 ohms
AM TUNER SECTION:	
Frequency Range	515 ~ 1650 kHz
Usable Sensitivity 26 dB S/N 30% Mod., 1 MHz	25 µV
Selectivity 1 MHz, ±9 kHz	20 dB
Image Rejection, 1 MHz	18 dB
IF Rejection, 1 MHz	3 dB
Spurious Response Rejection, 1 MHz	60 dB
Signal-to-Noise Ratio, 1 MHz	52 dB
Frequency Response 1 MHz, ±3 dB	40 Hz ~ 2.3 kHz
Total Harmonic Distortion, 1 MHz	0.5%
GENERAL:	
Power Requirements	200 V ~ 50 Hz
(E and N versions are featuring an external voltage selector for use on 110/120/240V. Other versions can be converted by a qualified technician to operate on 110/120/240V.)	
Power Consumption at rated output, both channels	
operating	97 W ± 15 W
Idling Power	27 W ± 5 W
Semiconductor Complement	
Integrated Circuits	5
Transistors	29
Diodes	18
Field Effect Transistors	1
Dimensions	
Panel Width	440 mm (17-5/16 inches)
Panel Height	137 mm (5-25/64 inches)
Depth	293 mm (11-17/32 inches)
Weight	
Unit Alone	9.0 kg (19.8 lbs)
Packed for Shipment	10.5 kg (23.1 lbs)

Model 2216B



marantz

MARANTZ CO., INC. · P. O. BOX 577 · CHATSWORTH, CALIFORNIA · 91311

A WHOLLY-OWNED SUBSIDIARY OF SUPERSCOPE INC., CHATSWORTH, CALIFORNIA · 91311

