

SERVICE MANUAL

YP-D10

YP-D10



SINCE 1887



YAMAHA

NIPPON GAKKI CO., LTD. HAMAMATSU, JAPAN

004339

January 78 1.8K   Printed in Japan

CONTENTS

- PACKAGE INSTRUCTION 2
- SPECIFICATIONS 3
- APPELLATION OF PARTS 3
- DISASSEMBLY PROCEDURES..... 4
- ADJUSTMENTS 5
- OUTLINE OF CIRCUITS 6
- BLOCK DIAGRAM 8
- WIRING 9
- CIRCUIT BOARDS 9
- SCHEMATIC DIAGRAM 11
- EXPLODED VIEW 12
- PARTS LIST 13

PACKAGE INSTRUCTION

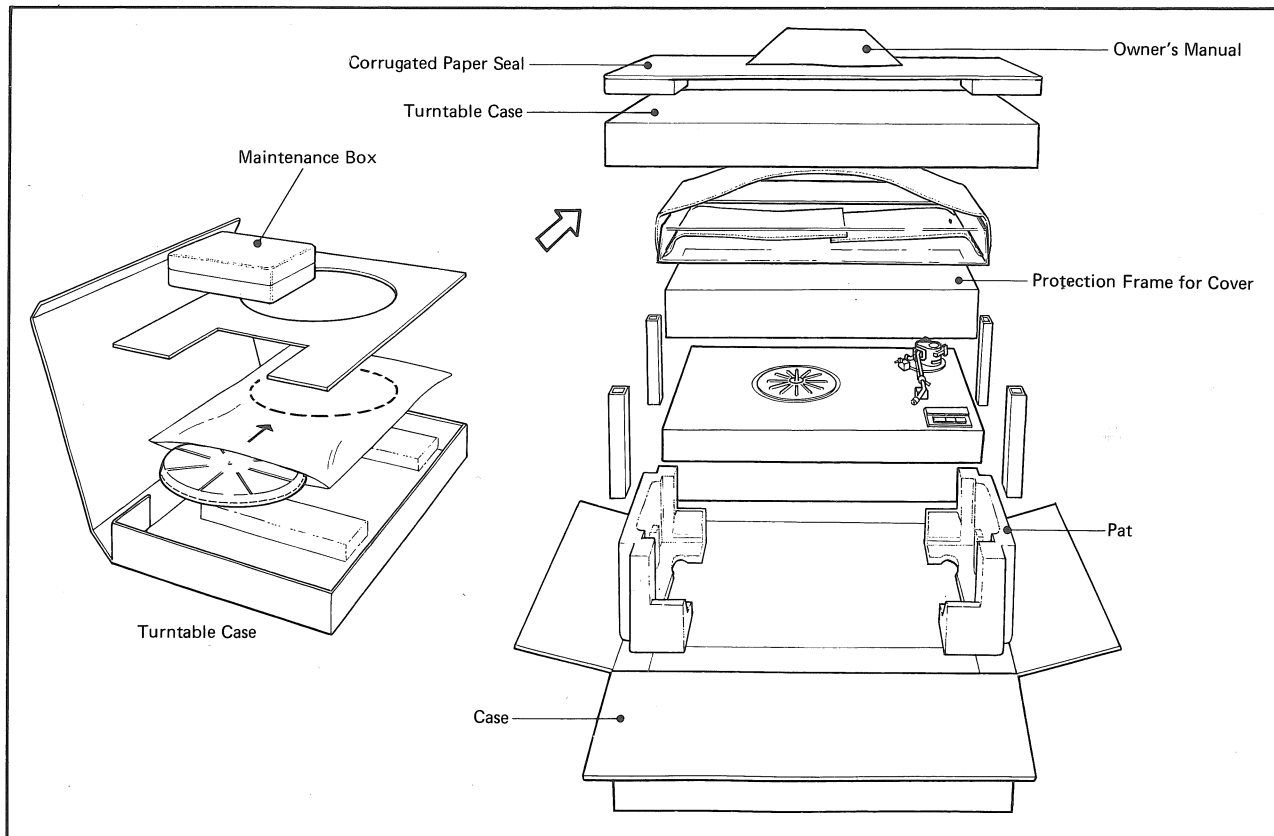

SPECIFICATIONS

TURNTABLE MOTOR SECTION

Drive System	Direct drive
Motor	12-Pole 24-slot DC Hall motor
Servo-Control System	Switchable: Quartz PLL/FG
Quartz Oscillator Frequency	4.32 MHz
Turntable Platter	31 cm (12-1/4") die-cast aluminum. Weight, 2.4 kg (5 lb 5 oz). Moment of inertia, 350 kg·cm ² including rubber platter mat, with single stroboscope marks around the turntable skirt.
Strobe Pulses	Excited by quartz crystal oscillator
Wow and Flutter (wrms)	Less than 0.03%
Single-to-Noise Ratio	Better than 73 dB (DIN-B)
Speed Accuracy (Quartz PLL-ON)	±20 ppm
Deviation Under Load (Quartz PLL-ON)	No deviation in speed for loads under 600g·cm
	(Quartz PLL-OFF) 0.003%/g·cm
Fine Speed Adjustment (Quartz PLL-OFF)	±3%

TONARM SECTION

Arm Type	S-type static balance arm with gimbal supports
Tonearm Length	320 mm (12-5/8")
Tonearm Effective Length	232 mm (9-1/8")
Overhang	16 mm
Sensitivity	Vertical, 3 mg; horizontal, 5 mg
Tonearm Stand Base	Diecast zinc
Anti-Skating Device	Counterweight and strung roller

Auto-Up Stop	Non-contact photo-electric speed detector, linked with cueing lever and power OFF switch.
Headshell	Diecast aluminum alloy (interchangeable to EIA specs: weight 11 g)
Possible Cartridge Weights	4 ~ 16 g (with headshell provided)
Output Leads	Gold-plated plugs fitted, using NEGLEX type wire

GENERAL

Power Supplies	120V/60Hz (US. and CANADA) 240V/50Hz (UK. and AUSTRALIA) 110, 130, 220, 240V/50, 60 Hz (EUROPE and General export models)
Power Consumption	10 W
Cabinet	High density coniferous particle board with black polyurethane open-pore decorative paint finish
Dust Cover	Acrylic
Hinges	Free-setting, detachable
Acoustic Insulators	Large double-type insulators, with adjustable height.
Dimensions (W x H x D)	470 x 163 x 378 mm (18-1/2" x 6-1/16" x 14-7/8")
Weight	16 kg (35 lb 4 oz)

Specifications subject to change without notice.

APPELLATION OF PARTS (The photo depict the UL model)

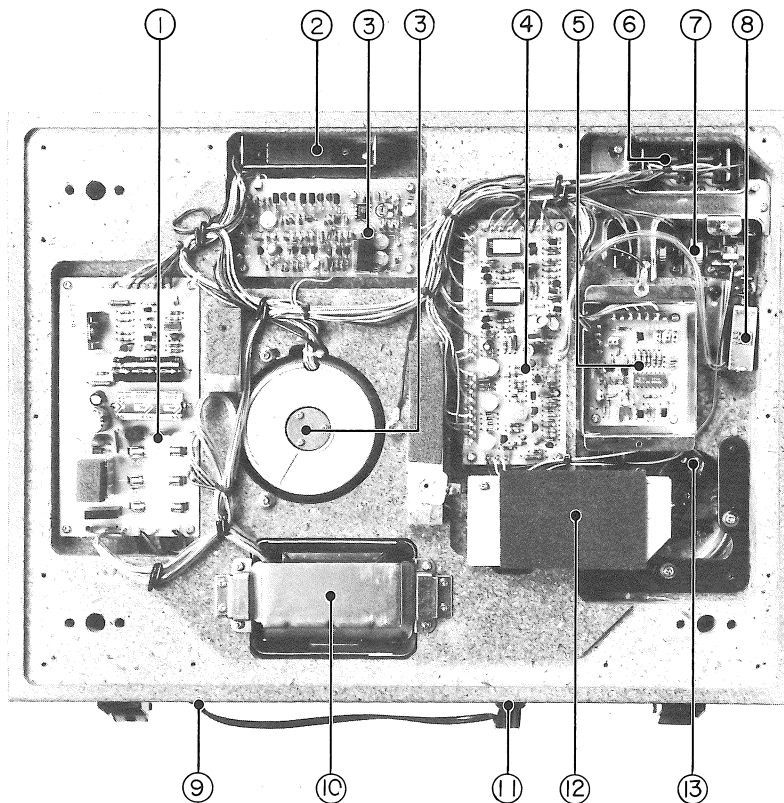

- ① Power C. Board
- ② Stroboscope
- ③ Motor & Motor C. Board Assembly
- ④ Control C. Board
- ⑤ PL. C. Board
- ⑥ LED C. Board
- ⑦ Control Block
- ⑧ Solenoid Plunger
- ⑨ AC Cord
- ⑩ Power Transformer
- ⑪ Output Cord
- ⑫ Shield Plate
- ⑬ DET. C. Board

DISASSEMBLY PROCEDURES

Before disassembling the unit, remove the platter and cartridge, and securely tie the arm to the arm rest with string, etc. Then, gently turn the unit upside-down and place it on books, etc. piled up on both sides to protect the arm and cabinet from damage.

1. Rear Panel Removal

Remove 16 screws and washers, then take the rear panel out.

2. Tonearm Removal

Remove the shield plate by unscrewing two screws (Photo 1) and also, remove six lead wires (see color code in Photo 1), DET printed circuit board and lifter wire. Here, it is recommended to remove the lifter wire from the controls section rather than from the arm section. Finally, remove three sets of screws, S-washers and flat washers, all securing the tonearm assembly.

Note: When the arm assembly is reattached, re-adjustment of the auto-return position is needed (see "ADJUSTMENTS"). Therefore, do not dismantle the arm assembly unless required.

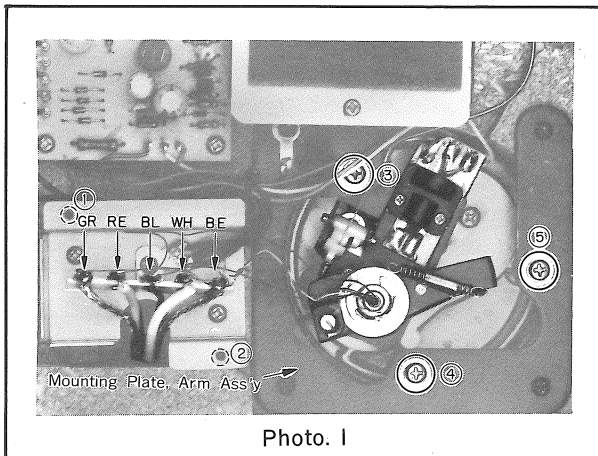

Photo. 1

3. Controls Removal

3.1 Removal of switch mounting board

Take off the screws ① to ⑥ shown in Photo 2. This condition is shown in Photo 3.

3.2 Removal of switches and variable resistors

Remove screws ① to ⑥ and hexagonal supports ⑦ to ⑩, shown in Photo 3. Now you can remove the respective parts. Here, be careful not to remove screws other than the above.

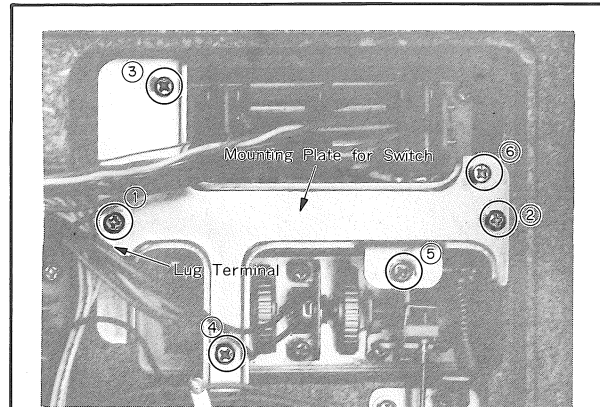

Photo. 2

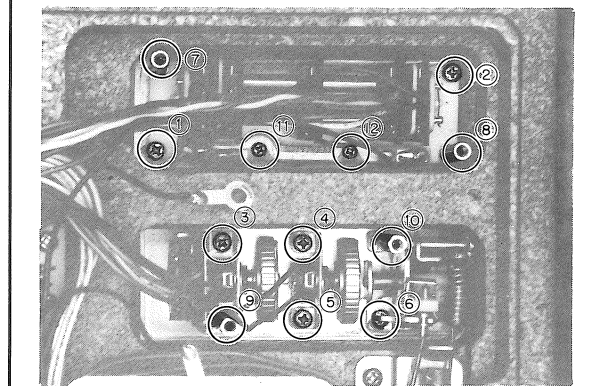

Photo. 3

4. Motor Removal

Remove the motor-shielding board from the cabinet surface first and unscrew ① to ③ securing the motor shown in Photo 4. After that, remove the motor together with the motor-mounting board without disconnecting 15 lead wires connected to the copper-plated side of the motor-mounting board, since the motor and the motor-mounting board are monolithically assembled.

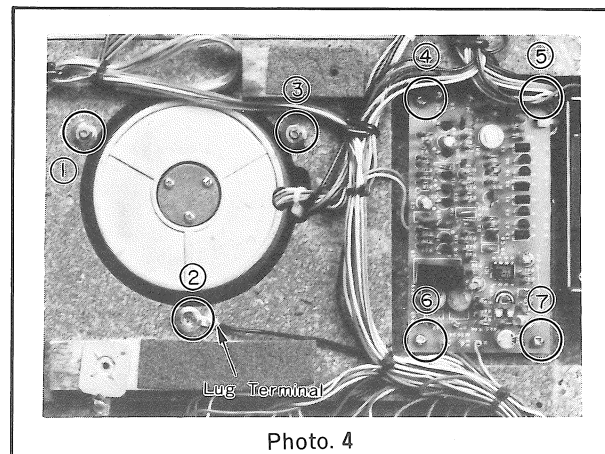

Photo. 4

ADJUSTMENTS

1. Circuit Board Adjustments

■ PL Circuit Board

Oscillating-frequencies check (4.32MHz): Connect a frequency counter to the collector of TR302.

■ Motor Circuit Board (PLL R.P.M adjustment)

Among adjusting points of the motor circuit board, VR1 and VR4 require exclusive jigs for adjustment. They are, however, completely pre-adjusted before shipping. So, never touch or adjust them; otherwise the performance will be deteriorated or normal functions will not be achieved.

[VR2] 45 rpm

[VR3] 33-1/3 rpm

Connect an oscilloscope between PD and E terminals of the control circuit board. Next, turn on the PLL switch and SPEED SELECTOR switch (33/45). Finally, adjust VR2 (45 rpm) and VR3 (33-1/3 rpm) so that they are stabilized when the duty ratio of square wave on the oscilloscope is 1 ± 0.2 .

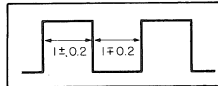

■ Control Circuit Board (FG rpm adjustment)

Be sure to make this adjustment after completion of motor circuit board adjustment.

[VR202] 33-1/3 rpm

[VR203] 45 rpm

Set the PLL switch to OFF FG (Frequency Generator) position, and set the fine adjustment knob, located in controls section, to the center of the variable range. Then, turn on the SPEED SELECTOR switch (33/45). Finally, adjust VR202 (33-1/3 rpm) and VR203 (45 rpm) by rotating so that movement of the strobo markings stops.

■ Control Circuit Board (auto-return adjustment)

[VR206] CdS bias voltage

Connect a DC voltmeter (with input impedance of not less than 100 k Ω) between CdS and 1+ terminals of the control Circuit Board. And turn on the SPEED SELECTOR switch (33/45). (The arm is positioned on the arm rest.) Fully turn VR206 clockwise, then turn it back counter-clockwise until the voltmeter reads $10 \pm 0.2V$.

[VR205] Return point adjustment

After adjusting the mechanism, adjust VR205 while monitoring the output when the test record ES-1008 (NEC) is played.

1. Adjusting the return point (3mm pitch grooves on the first side of the test record.

Fully turn VR205 clockwise, then descend the cartridge onto the outside (count of 10 or less of the 3mm pitch grooves of the test record. After that, turn VR205 counter-clockwise so that the arm automatically ascends at count of

15 to 21. If this adjustment cannot be achieved at one time, repeat it for complete adjustment.

2. Confirming the non-action of the arm (1mm pitch grooves on the second side of the test record)

Confirm that the arm does not automatically ascend at count of 21 or more after the cartridge is lowered on the outside (count of 10 or less) of the 1mm pitch grooves of the test record. If the arm automatically ascends, make readjustment according to Item 1 "Adjusting the return point".

2. Mechanism Adjustment

(Positioning of the sub-arm assembly)

When the sub-arm assembly is removed for replacement of the arm, etc., the following adjustment will be required thereafter.

■ Rough adjustment (Attaching the sub-arm assembly)

With the tonearm locked on the arm rest, tighten the set screws so that the distance between the lamp holder and sub arm is 22 mm as illustrated below. Here, previously set the sub arm near the center of the adjustable range by means of the fine adjustment screw. Tighten the set screw 1 first and tighten the set screw 2 after turning the sub arm A clockwise, using a hexagonal wrench for M3 (1.5 mm dia.)

■ Fine adjustment (Setting the end groove position)

This fine adjustment is made while monitoring the voltage between CdS and 1+ terminals of the control circuit board. After setting VR206 (see "Circuit Board Adjustments"), move the tonearm so that the stylus tip is positioned at a distance of 53.2 mm from the center shaft — that is, the final groove on a template attached. Then, after having fully turned the fine adjustment screw for sub arm assembly clockwise, rotate it counter-clockwise so that the voltage between CdS and 1+ terminals becomes $5.0 \pm 0.1V$. Use a voltmeter with input impedance of 100 k Ω or more.

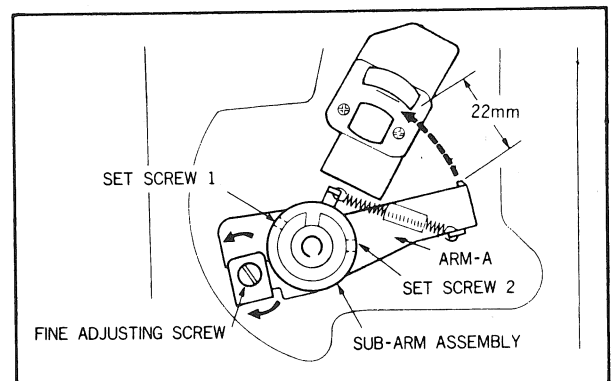

OUTLINE OF CIRCUITS

Quartz-Oscillating PLL Control

In conventional FG (Frequency Generator) servo control system, a Frequency Generator built into the motor induces a frequency proportional to the turntable speed. Feedback is introduced to keep the Frequency at a constant value. Stability against load fluctuations, however, is restricted since the feedback value is limited. Furthermore, when the turntable speed is controlled by a strobo synchronous with the power frequency, accuracy of the speed is limited to that of the power frequency (instantaneous variations $\pm 0.5\%$, normal $\pm 0.2\%$). On the contrary, this unit's PLL (Phase Locked Loop) control system is a servo system that is designed to reduce the phase difference between FG frequency and a quartz-oscillating frequency by means of feedback gain. As a result, accuracy of turntable speed can be improved up to that of the quartz-oscillating frequency (0.002%). Also, this PLL control system is, in principle, unaffected by DC load changes — for instance, changes in tracking force. (In case of the YP-D10, tracking force is ineffective up to about 120 g, and the friction factor is 0.3 under load at the extreme outside groove).

The PLL control system is active when the phase difference between frequencies is within $\pm 180^\circ$, it does not work when the phase difference is over $\pm 180^\circ$ since this cannot be detected. To cope with this disadvantage, the FG servo system is employed simultaneously.

Generally, the PLL control system hardly responds to dynamic load variations (disturbance torque), but well responds to extremely slow load variations. For load variations to which the PLL cannot respond, the FG servo system is effective. Moreover, inertia torque of the turntable (350 kg-cm) absorbs higher speed load variations (wow and

flutter).

Elements of PLL

The PLL circuit consists of five transistors and one IC on PL printed circuit board, which is housed in a shielded case to prevent radio interference. The PLL consists mainly of a reference frequency oscillating circuit, a phase comparing circuit, low pass filter and VCO (Voltage-controlled oscillator). In this unit, the FG motor serves as VCO.

By dividing the quartz-oscillating frequency of 4.32 MHz, the reference frequency is adjusted to match the frequency (100 Hz/33 rpm or 135 Hz/45 rpm) from the FG motor. After that, if a phase difference is observed when both frequencies are compared, a corresponding DC voltage will be induced. The output derived from the phase-comparing circuit contains the input frequencies (100 and 135 Hz). Therefore, only direct currents are derived through low-pass filters (R309, C310/R231, and C206).

Those direct currents control a motor drive circuit, and the motor oscillates at a frequency corresponding to its speed. Accordingly, a loop system whose frequency is compared with the reference frequency is repeated infinitely. Thus, an extremely stable speed which is synchronous with the reference frequency can be always obtained.

IC YM27500 for PLL

Shown below is the block diagram of YM27500.

IC REPLACEMENT NOTE

The YM27500 is a MOS type IC which has high input impedance at each port, so that there is danger of electrostatic damage when terminals are left open. When replacing the IC, previously provide grounding of serviceman himself and metal portion of the soldering iron.

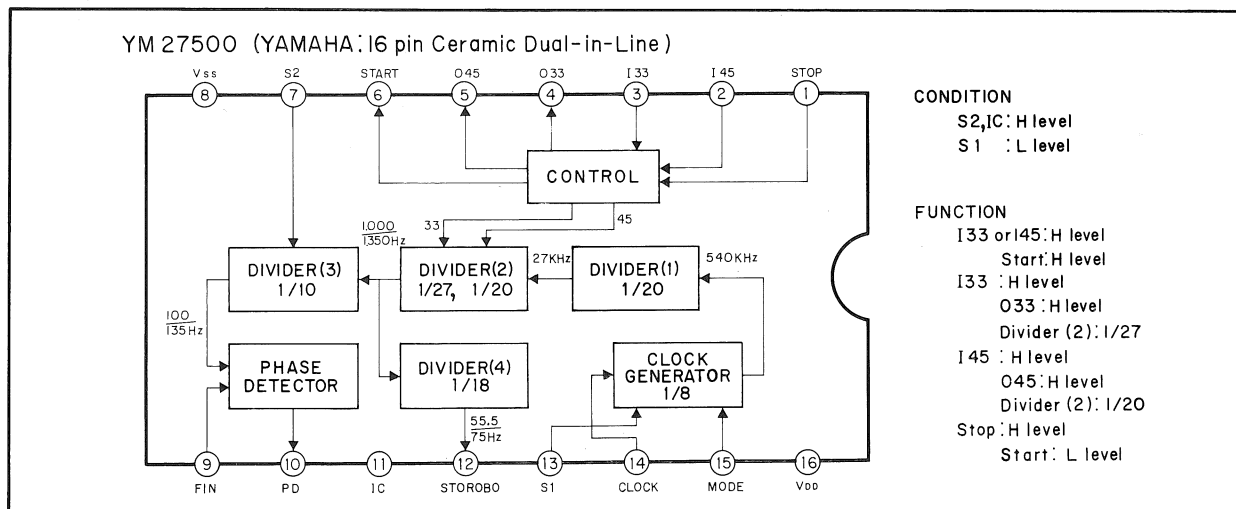

■ BLOCK DIAGRAM

■ Non-contact Photo-electric Detection Auto Stop

The YP-D10 employs a photo-electric detection auto stop mechanism that detects the end groove of the record, lifts the arm and simultaneously turns off the power.

In the end groove detection mechanism, a shutter interlocked with the arm is inserted between LED and CdS. This shutter serves to block light between

LED and CdS. At this time, the speed of the shutter is detected to actuate electric circuits which operate the cueing lever through a solenoid plunger. Thus, this non-contact photo-electric detection system poses no load to the arm and has no adverse effect on tracking ability. Shown below is a block diagram of the non-contact photo-electric detection system.

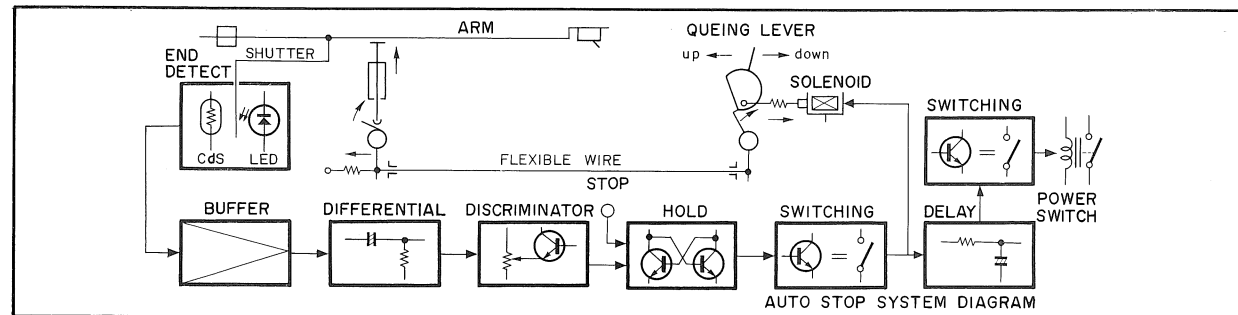

[Start]

When the switch 33 or 45 is pressed, a micro-switch turns on the primary side of the power transformer, and current flows to the circuits. At the same time, another microswitch functions in the control block of IC301 (see the block diagram on the preceding page) to select the speed and to turn on TR111 and TR212. As a result, a relay (RY101) actuates, and the primary side of the power transformer remains in ON condition.

When the power source circuit is turned on, current momentarily flows into C203 on the control circuit board to actuate a flip-flop circuit which holds TR205 in ON condition and TR204 in OFF condition.

[Detection Circuit]

When the stylus tip approaches the end of the record, the shutter interlocked with the arm (sub arm) inserts between LED and CdS to change the amount of light which is radiated to CdS. Therefore, the resistance value of CdS increases. When the stylus tip traces the inside grooves with rough pitches (4 to 9 mm - JIS) after the end of play, the resistance of CdS changes rapidly. The resistance of CdS determines the base voltage of TR201, changes in the resistance appear at the emitter of TR201 (emitter follower) and are transmitted to the gate of FET202 through C202.

C202 and R206 constitute a differentiation circuit. This means the higher the change speed, the shorter the rising time and the higher the trigger wave height. Thus, the end of the record can be detected by means of the inside rough pitch grooves.

[Discriminating Circuit]

VR205 (see Item "ADJUSTMENT") delivers the bias voltage to the emitter of TR218 to discriminate whether the waveform of currents from the detection circuit is caused by rough pitch grooves or not. This discriminating circuit actuates when groove pitch is 3 mm or more, and prevents erroneous operation due to eccentricity of the record (loose fit between the center shaft and record hole). Only the waveform above the Zener voltage of the inverse-connected D221 can pass the discriminating circuit.

[Hold Circuit]

This hold circuit holds TR205 in ON condition and TR204 in OFF condition when the power is turned on. When the pulse that passes D221 is transmitted to the base of TR204, the hold circuit is inverted.

[Switching Circuit]

At the moment when TR205 is turned off, the rising portion of the voltage passes through C212, which turns on TR219 and TR206. As a result, the solenoid plunger is actuated to operate the cueing lever. Thus lifting of the arm is completed.

[Delay Circuit and Relay Off Circuit]

The pulse that drives the solenoid plunger is simultaneously delivered to a delay circuit consisting of R217 and C211. After a lapse of time until the action of the plunger is completed, switching is made to TR207, TR209 and TR210. As a result, the base voltage of TR211 becomes zero, and the relay RY101 is switched off. This turns off the power switch interlocked with the relay. Now the circuitry is completely shut off. (Refer to the attached schematic diagram.)

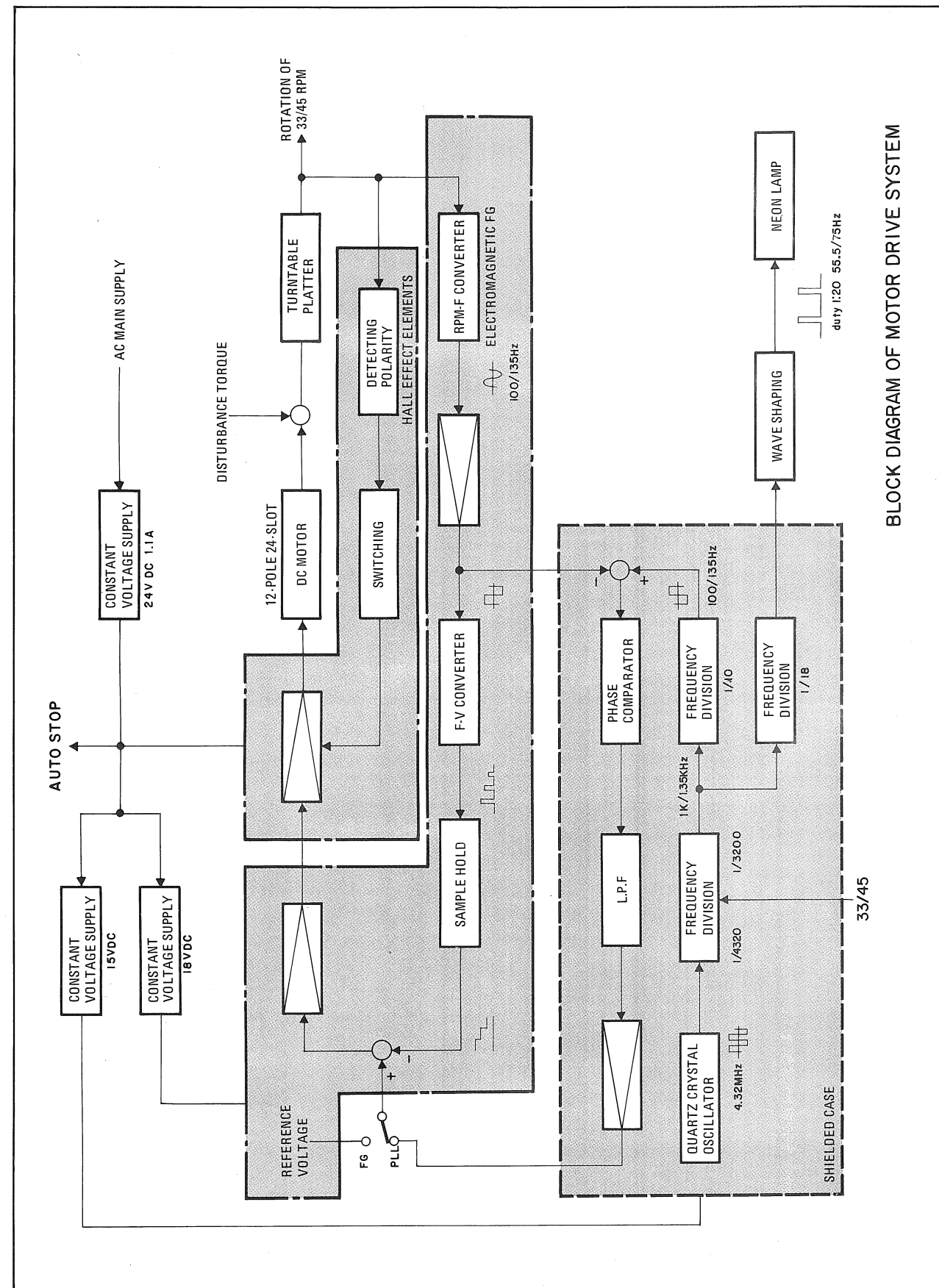

WIRING

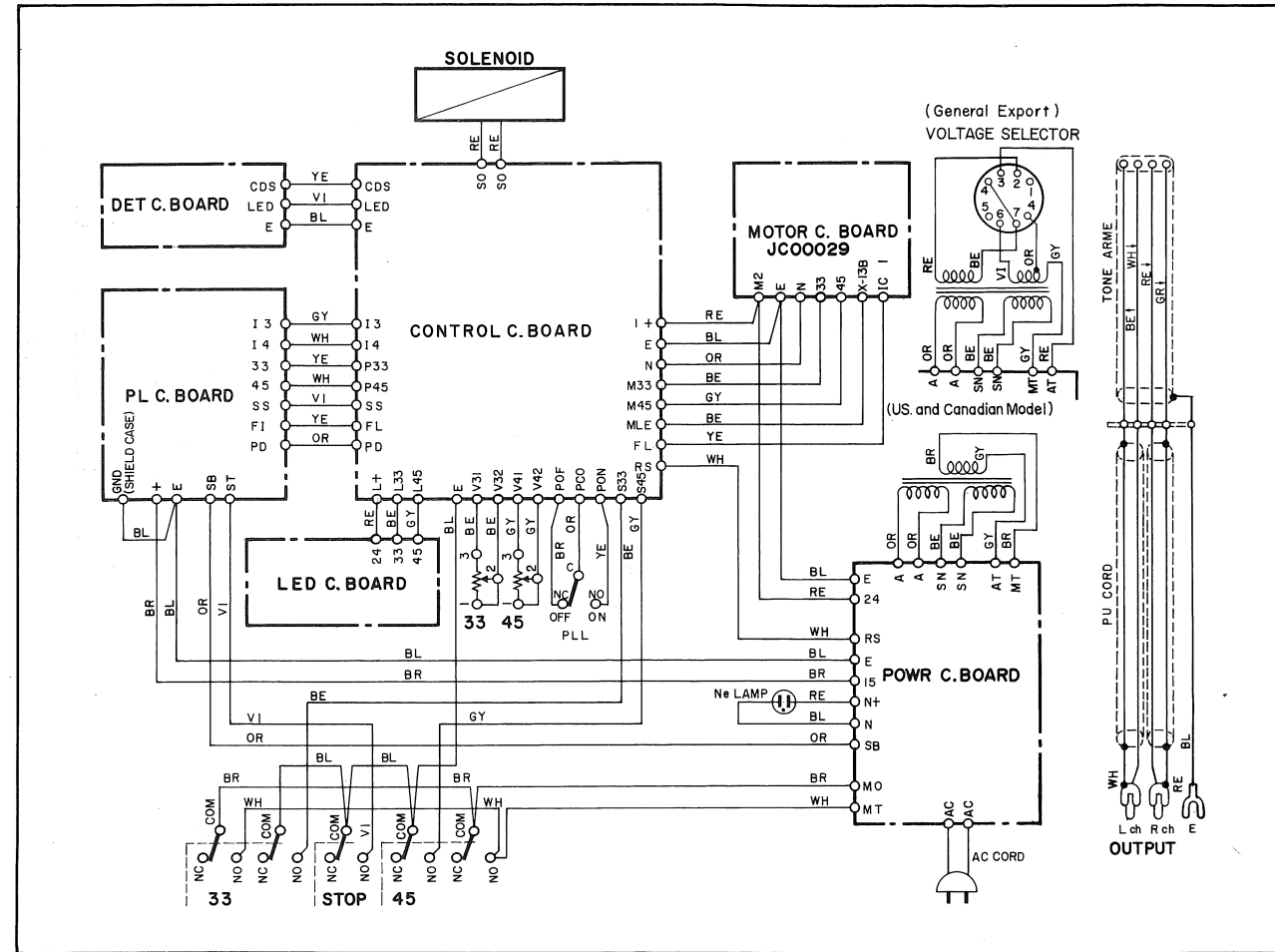

CIRCUIT BOARDS
POWER C. BOARD

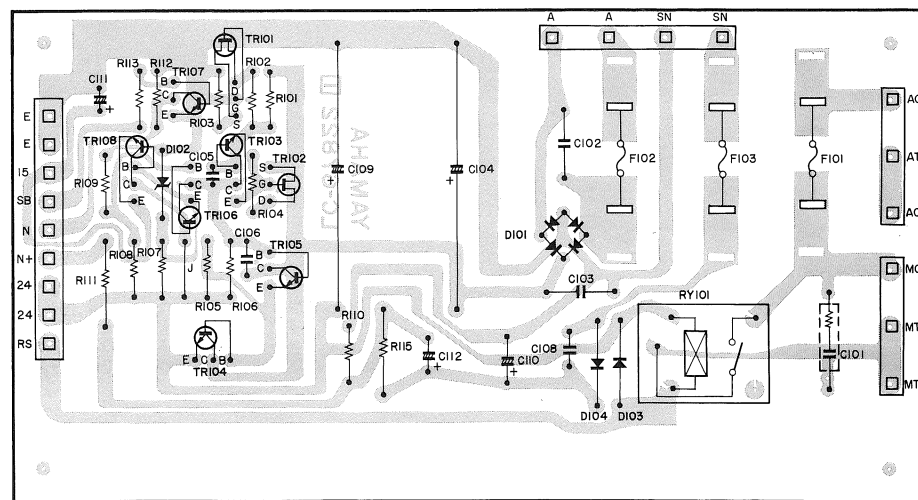

(US. and Canadian Model)

CONTROL C. BOARD

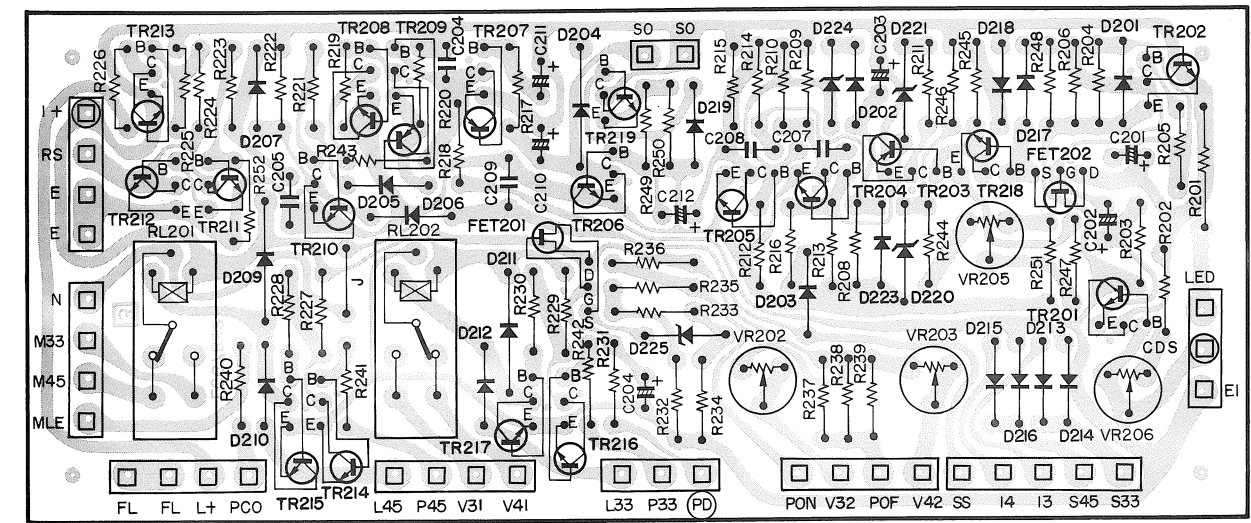

○; TEST POINT

MOTOR C. BOARD

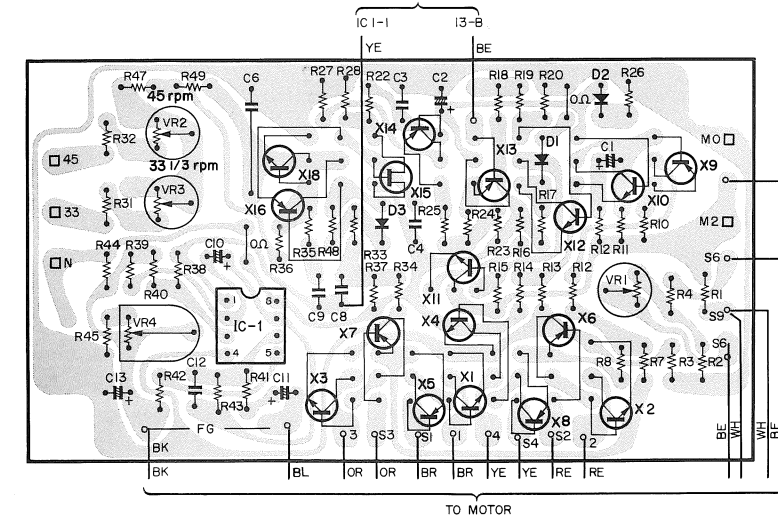

TO MOTOR

PL. C. BOARD

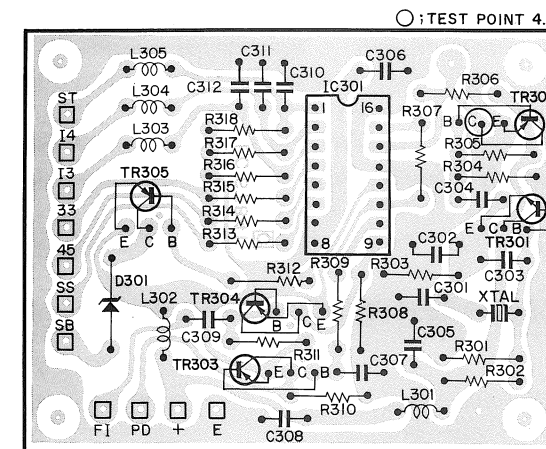

○; TEST POINT 4.32 MHz

LED C. BOARD



DET C. BOARD

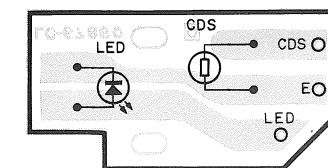

- CONTROL C. BOARD ADJUSTMENTS**
- * VR202 : 33 1/3 rpm (FG rpm adjustment)
 - * VR203 : 45 rpm (-do-)
 - * VR205 : Return point adjustment
 - * VR206 : Cds bias voltage adjustment

SCHEMATIC DIAGRAM

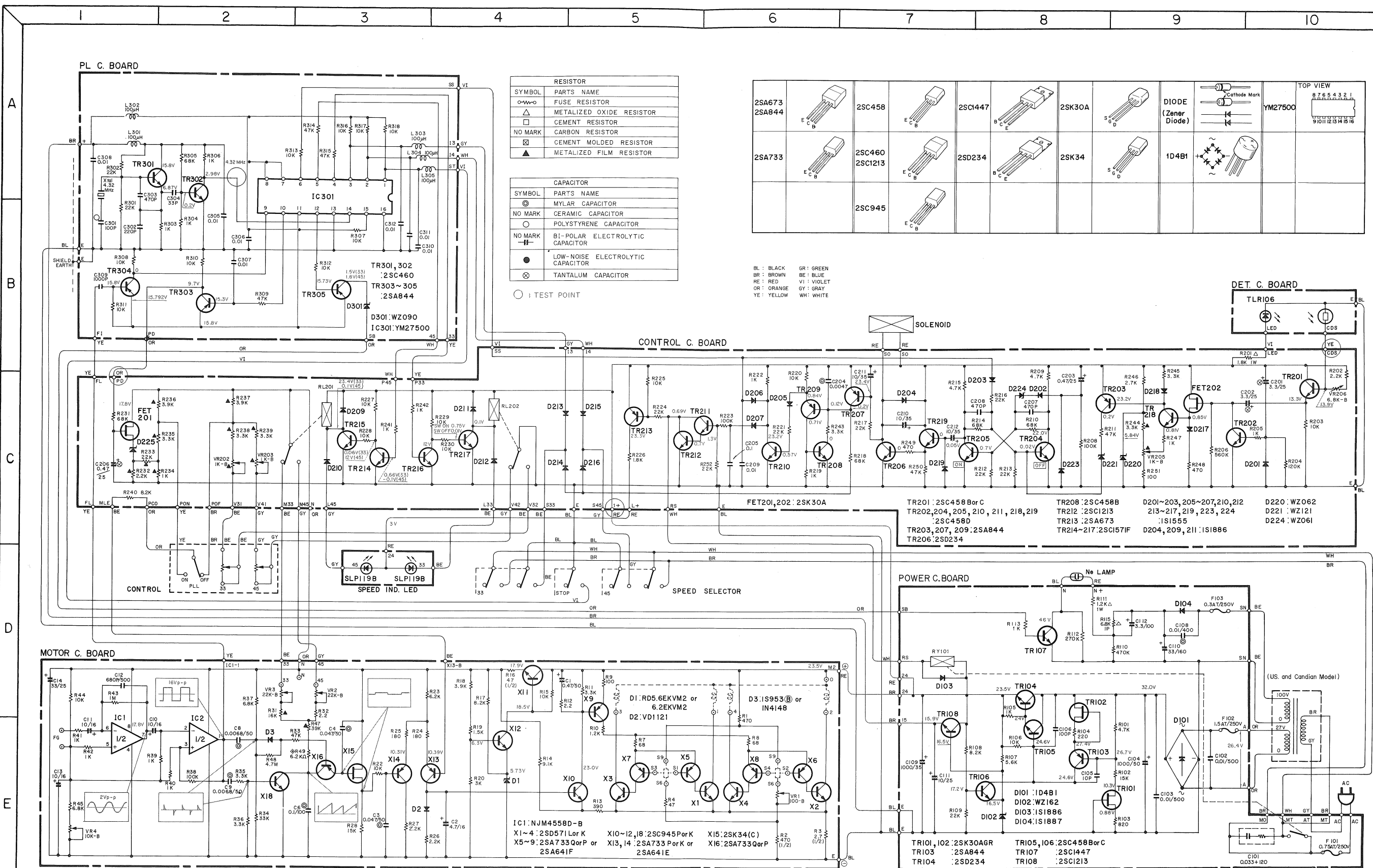

RESISTOR	
SYMBOL	PARTS NAME
	FUSE RESISTOR
	METALIZED OXIDE RESISTOR
	CEMENT RESISTOR
	CARBON RESISTOR
	CEMENT MOLDED RESISTOR
	METALIZED FILM RESISTOR

CAPACITOR	
SYMBOL	PARTS NAME
	MYLAR CAPACITOR
	CERAMIC CAPACITOR
	POLYSTYRENE CAPACITOR
	BI-POLAR ELECTROLYTIC CAPACITOR
	LOW-NOISE ELECTROLYTIC CAPACITOR
	TANTALUM CAPACITOR

○ : TEST POINT

2SA673 2SA844	2SC458	2SC1447	2SK30A	DIODE (Zener Diode)	YM27500		
2SA733	2SC460 2SC1213	2SD234	2SK34	1D4B1			
	2SC945						

BL : BLACK GR : GREEN
BR : BROWN BE : BLUE
RE : RED VI : VIOLET
OR : ORANGE GY : GRAY
YE : YELLOW WH : WHITE

※ When it is not possible to adjust with adjusting resistors VR2 and VR3 then replace them with resistors of 2.2~10KΩ.

EXPLODED VIEW

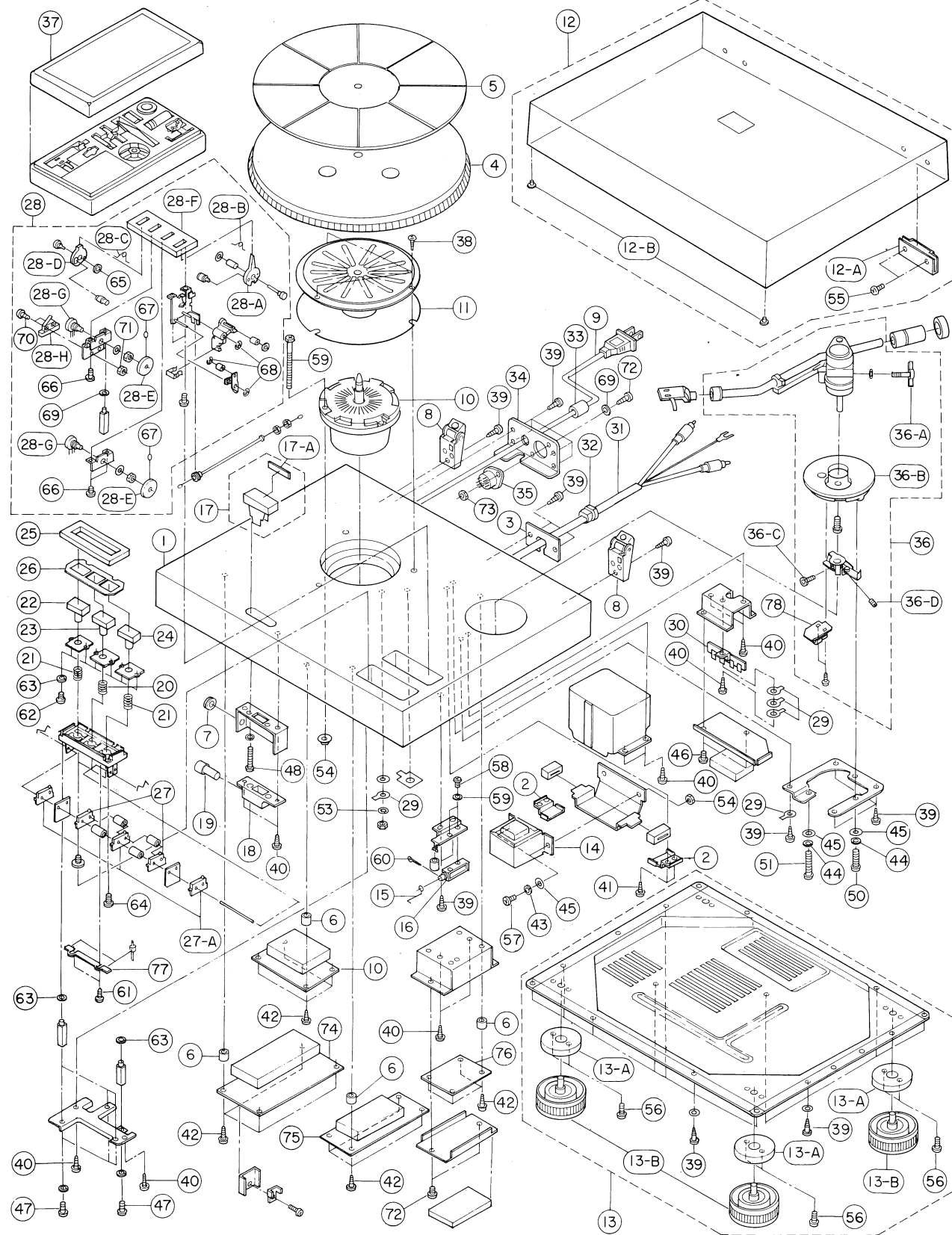

PARTS LIST

Ref. No.	Part No.	Description	Markets	Remarks
1	320094.25 61.66.10	Cabinet	U,C	
	320094.25 61.75.10	-do.-	R	
2	320000A A 08.40.80	Transformer Fixing Metal		
3	320000A A 08.41.10	Cord Holder		
4	320000B A 07.01.90	Turntable Platter		
5	320000C B 08.19.60	Rubber Mat	R,E,A,B,C	
	320000C B 08.30.30	-do.-	U	
6	420000C B 01.09.80	Spacer		
7	320000C B 07.58.70	Bush		
8	320000N B 08.23.50	Hinge Ass'y		
9	420000M G 00.03.40	AC Cord POT64 #18		
10	420000J C 00.02.90	Motor and Motor C.Board Ass'y		
11	420000C B 07.85.90	Cushion, Shield Plate		
12	320000N B 08.03.50	Top Cover Ass'y		
12-A	320000A A 08.90.40	Lock Plate		
12-B	320000C B 07.40.20	Rubber for Top Cover		
13	320000N B 08.03.80	Bottom Cover Ass'y		
13-A	320000A A 08.46.30	Insulator Cover		
13-B	320000N B 08.23.30	Insulator Ass'y	R,E,A,B,C	
1	320000N B 08.29.80	-do.-	U	
14	420000G A 61.37.00	Power Transformer	R,A,B,E	
1	420000G A 61.36.00	-do.-	U,C	
15	320000A A 08.76.40	Solenoid Rod		
16	420000J F 00.00.50	Solenoid		
17	320000N B 08.04.10	Strobo Case Ass'y		
17-A	320000C B 08.02.30	Lens, Strobo		
18	320000C B 08.02.50	Neon Lamp Case		
29	420000J B 00.05.20	Neon Lamp NL-79		
20	320000A A 08.60.30	Spring Button A		
21	320000A A 08.60.40	-do.- B		
22	320000B A 07.09.40	Push Button 45		
23	320000B A 07.09.30	-do.- STOP		
24	320000B A 07.06.30	-do.- 33		
25	320000B A 07.06.90	Make-up Plate, Switch		
26	320000C B 08.02.20	Bottom Guide		
27	420000K A 60.02.80	Micro Switch AH24044	R,U,C	
27-A	420000K A 60.02.70	-do.- AH2404	R,U,C,A,B	
28	320000N B 08.04.40	Make-up Plate VR Ass'y		
28-A	320000B A 07.06.40	Lever A		
28-B	320000A A 08.59.50	Spring		
28-C	320000A A 08.89.00	-do.-		
28-D	320000B A 07.06.50	Lever B		
28-E	320000B A 07.08.10	Knob, Variable Resistor		
28-F	320000N B 08.04.60	Make-up Plate, Variable Resistor		
28-G	420000H S 13.00.10	Variable Resistor φ13 B-1K		
28-H	420000K A 60.02.30	Micro Switch AH2424		
39	420000L A 00.02.90	Lug Terminal φ4mm		
30	420000L A 00.01.10	-do.- 4pIL P=10		
31	420000M i 06.63.30	PU Cord		

Ref. No.	Part No.	Description	Markets	Remarks
32	420000:CB 0784:50	Cord Stopper HEYCO SR-30-1		
33	420000:CB 0706:90	-do.- EA-5		
34	320000:AA 0882:80	Rear Panel	R	
	320000:AA 0882:70	-do.-	U,C	
	320000:AA 0882:90	-do.-	E	
35	420000:LB 2002:50	Voltage Selector	R,E	
36	320000:SS 0601:20	Tone Arm Unit (YA-18)	R,E,A,B,C	
	320000:SS 9900:10	-do.-	U	
36-A	320000:BE 0602:20	Lock Shaft		
36-B	320000:BE 0603:30	Arm Base		
36-C	420000:EZ 0004:20	Hexagonal Set Screw	M3×6	
36-D	420000:EZ 0002:10	-do.-	M3×4	
37	320000:NB 0808:60	Maintenance Box		
38	420000:EQ 3311:30	Round Head Wood Screw	3.1×13 ZMC2-Bℓ	
39	420000:EQ 3311:60	-do.-	3.1×16 -do.-	
40	420000:EQ 0311:30	-do.-	3.1×13 ZMC2-Y	
41	420000:EQ 0311:60	-do.-	3.1×16 -do.-	
42	420000:EQ 0312:00	-do.-	3.1×20 -do.-	
43	420000:EV 3003:00	Spring Lock Washer	φ3 -do.-	
44	420000:EV 3004:00	-do.-	φ4 -do.-	
45	420000:EV 2004:00	Flat Washer	φ4 -do.-	
46	420000:EH 0300:60	Sems Screw	M3×6 -do.-	
47	420000:EH 0300:80	Cums Screw	M3×8 -do.-	
48	420000:EA 0302:50	Pan Head Screw	M3×25 -do.-	
49	420000:EA 0406:50	-do.-	M4×65 -do.-	
50	420000:EA 0402:50	-do.-	M4×25 -do.-	
51	420000:EA 0403:50	-do.-	M4×35 -do.-	
52	420000:EL 0300:60	Tap Tight Screw	M3×6 -do.-	
53	420000:EV 4100:40	Toothed Lock Washer	φ4 FNM3-3G	
54	420000:EV 1004:00	Hexagonal Nut ※	M4 ZMC2-Y	
55	420000:ED 3300:80	Bind Head Screw	M3×8 ZMC2-Bℓ	
56	420000:EJ 3300:60	Pan Head Tapping Screw	M3×6 -do.-	
57	420000:EH 0400:80	Cums Screw	M4×8 ZMC2-Y	
58	420000:EA 0260:50	Pan Head Screw	M2.6×5 -do.-	
59	420000:EV 3002:60	Spring Lock Washer	φ2.6 -do.-	
60	420000:EZ 0005:10	Sprit Pin	φ2 12ℓ	
61	420000:EN 0101:10	Tapping Screw	M2.6×6	
62	420000:EA 0300:50	Pan Head Screw	M3×5 ZMC2-Y	
63	420000:EV 3003:00	Spring Lock Washer	φ3 -do.-	
64	420000:EA 0301:20	Pan Head Screw	M3×12 -do.-	
65	420000:EV 2003:00	Flat Washer	φ3 -do.-	
66	420000:EH 0300:60	Sems Screw	M3×6 -do.-	
67	420000:EZ 0000:70	Hexagonal Socket Head Screw	M3×3	
68	420000:EV 5012:00	E Ring	φ2 FNM3-3G	
69	420000:EV 3003:00	Spring Lock Washer	φ3 ZMC2-Y	
70	420000:EA 0201:00	Pan Head Screw	M2×10 -do.-	
71	420000:EV 1002:00	Hexagonal Nut	M2 -do.-	
72	420000:EA 3300:80	Pan Head Screw	M3×8 ZMC2-Bℓ	
73	420000:EV 1003:00	Hexagonal Nut	M3 ZMC2-Y	

※ When servicing, add flat washer (EV200400)

Ref. No.	Part No.	Description	Markets	Remarks
74	320000:NA:069790	Power Supply C.Board	U	
	320000:NA:069800	-do.-	C	
	320000:NA:069780	-do.-	E,B,A	
	320000:NA:069810	-do.-	R	
TR101	420000:i E 000020	FET 2SK30A GR		
102	420000:i E 000020	-do.- 2SK30A GR		
103	420000:i A 084400	Transistor 2SA844		
104	420000:i D 023400	-do.- 2SD234		
105	420000:i C 045830	-do.- 2SC458 C		
106	420000:i C 045830	-do.- 2SC458 B.C		
107	420000:i C 144700	-do.- 2SC1447		
108	420000:i C 121330	-do.- 2SC1213		
D101	420000:i H 000470	Diode 1D4B1		
102	420000:i F 000650	Zener Diode WZ162		
103	420000:i H 000025	Diode 1S1886		
104	420000:i H 000330	-do.- 1S1887		
R101	420000:HK 356470	Carbon Resistor 4.7K		
102	420000:HK 357150	-do.- 15K		
103	420000:HK 355820	-do.- 820		
104	420000:HK 355220	-do.- 220		
105	420000:HK 356100	-do.- 1K		
106	420000:HK 357100	-do.- 10K		
107	420000:HK 356560	-do.- 5.6K		
108	420000:HK 356820	-do.- 8.2K		
109	420000:HK 357220	-do.- 22K		
110	420000:HK 358470	-do.- 470K		
111	420000:HL 416120	Metal Oxide Film Resistor 1P 1.2kΩ		
112	420000:HK 358270	Carbon Resistor 270K		
113	420000:HK 356100	-do.- 1K		
115	420000:HL 416680	Metal Oxide Film Resistor 1P 6.8kΩ		
C101	420000:FZ 000110	Spark Killer Capacitor 0.033μF 120V	U	
	420000:FZ 001150	-do.- 0.033μF 125V	C	
	420000:FZ 000690	-do.- 0.022μF 250V	E,A,B	
	420000:FZ 000540	-do.- 0.033μF 350V	R	
102	420000:FH 234100	Ceramic Capacitor 0.01μF		
103	420000:FH 234100	-do.- 0.01μF		
104	420000:FK 169100	Electlytic Capacitor 1000μF 50V		
105	420000:FG 211100	Ceramic Capacitor 10pF		
106	420000:FG 212100	-do.- 100pF		
108	420000:FC 044100	Mylar Capacitor 0.01μ 400V		
109	420000:FK 159100	Electrolytic Capacitor 1000μ 35V		
110	420000:FJ 407330	-do.- 33μ 160V		
111	420000:FJ 347100	-do.- 10μ 25V		
112	420000:FJ 296330	-do.- 3.3μ 100V		
F101	420000:KB 001220	UL Fuse 750mA 250V	U,C	

Ref. No.	Part No.	Description	Markets	Remarks
102	420000:KB 00:12:90	-do.- 1.5A 250V	U,C	
103	420000:KB 00:10:00	UL Fuse 0.3A 250V	U,C	
F101	420000:KB 00:07:40	S Fuse 1.6AT 250V	E,Bs	
102	420000:KB 00:06:70	-do.- 630mA 250V	E,Bs	
103	420000:KB 00:06:50	-do.- 315mA 250V	E,Bs	
	420000:KC 00:04:80	Relay AZ535-08-2		
	320000:BA 06:94:50	Heat Sink		
	420000:LA 00:20:30	Lapping Pin Type I 4P P=5		
	420000:LA 00:20:40	-do.- 5P P=5		
	420000:LA 00:21:60	-do.- 4P P=10		
	420000:LA 00:21:50	-do.- 3P P=10		
75	320000:NA 06:97:30	Control C,Board		
TR201	420000:i C 04:59:10	Transistor 2SC458D		
202	420000:i C 04:59:10	-do.- 2SC458D		
203	420000:i A 08:44:00	-do.- 2SA844		
204	420000:i A 04:59:10	-do.- 2SC458 D		
205	420000:i A 04:59:10	-do.- 2SC458 D		
206	420000:i D 02:34:20	-do.- 2SD234 Y		
207	420000:i A 08:44:00	-do.- 2SA844		
208	420000:i C 04:58:20	-do.- 2SC458 B		
209	420000:i A 08:44:00	-do.- 2SA844		
210	420000:i C 04:59:10	-do.- 2SC458 D		
211	420000:i C 04:59:10	-do.- 2SC458 D		
212	420000:i C 12:13:30	-do.- 2SC1213 C,D		
213	420000:i A 06:73:10	-do.- 2SA673 A-CD		
214	420000:i C 15:71:20	-do.- 2SC1571 F		
215	420000:i C 15:71:20	-do.- 2SC1571 F		
216	420000:i C 15:71:20	-do.- 2SC1571 F		
217	420000:i C 15:71:20	-do.- 2SC1571 F		
218	420000:i C 04:59:10	-do.- 2SC458 D		
219	420000:i C 04:59:10	-do.- 2SC458 D		
FET 201	420000:i E 00:00:10	FET 2SK30 A-Y		
202	420000:i E 10:10:00	-do.- 2SK30 A-E		
D201	420000:i F 00:00:40	Diode 1S1555		
202	420000:i F 00:00:40	-do.- 1S1555		
203	420000:i F 00:00:40	-do.- 1S1555		
204	420000:i H 00:02:50	-do.- 1S1886		
205	420000:i F 00:00:40	-do.- 1S1555		
206	420000:i F 00:00:40	-do.- 1S1555		
207	420000:i F 00:00:40	-do.- 1S1555		
209	420000:i H 00:02:50	-do.- 1S1886		
210	420000:i F 00:00:40	-do.- 1S1555		
211	420000:i H 00:02:50	-do.- 1S1886		
212	420000:i F 00:00:40	-do.- 1S1555		

Ref. No.	Part No.	Description	Markets	Remarks
213	420000 i F 000040	Diode 1S1555		
214	420000 i F 000040	-do.- 1S1555		
215	420000 i F 000040	-do.- 1S1555		
216	420000 i F 000040	-do.- 1S1555		
217	420000 i F 000040	-do.- 1S1555		
218	420000 i F 000040	-do.- 1S1555		
219	420000 i F 000040	-do.- 1S1555		
220	420000 i F 000320	Zener Diode WZ061		
221	420000 i F 000200	-do.- WZ120		
223	420000 i F 000040	Diode 1S1555		
224	420000 i F 000320	Zener Diode WZ061		
R201	420000 HL 316180	Metal Oxide Film Resistor 1P 1.8K		
202	420000 HK 356220	Carbon Resistor 2.2K		
203	420000 HK 357100	-do.- 10K		
204	420000 HK 358120	-do.- 120K		
205	420000 HK 356100	-do.- 1K		
206	420000 HK 358560	-do.- 560K		
208	420000 HK 358100	-do.- 100K		
209	420000 HK 356470	-do.- 4.7K		
210	420000 HK 357680	-do.- 68K		
211	420000 HK 357470	-do.- 47K		
212	420000 HK 357220	-do.- 22K		
213	420000 HK 357220	-do.- 22K		
214	420000 HK 357680	-do.- 68K		
215	420000 HK 356470	-do.- 4.7K		
216	420000 HK 357220	-do.- 22K		
217	420000 HK 357220	-do.- 22K		
218	420000 HK 357680	-do.- 68K		
219	420000 HK 356100	-do.- 1K		
220	420000 HK 357100	-do.- 10K		
221	420000 HK 357220	-do.- 22K		
222	420000 HK 356100	-do.- 1K		
223	420000 HK 358100	-do.- 100K		
224	420000 HK 357220	-do.- 22K		
225	420000 HK 357100	-do.- 10K		
226	420000 HK 356180	-do.- 1.8K		
227	420000 HK 357100	-do.- 10K		
228	420000 HK 357100	-do.- 10K		
229	420000 HK 357100	-do.- 10K		
230	420000 HK 357100	-do.- 10K		
231	420000 HK 357680	-do.- 68K		
232	420000 HU 576100	Metal Film Resistor 1K		
233	420000 HU 577100	-do.- 10K		
234	420000 HU 576100	-do.- 1K		
235	420000 HU 576330	-do.- 3.3K		
236	420000 HU 576390	-do.- 3.9K		
237	420000 HU 576390	-do.- 3.9K		
238	420000 HU 576330	-do.- 3.3K		

Ref. No.	Part No.	Description	Markets	Remarks
239	420000 HU 576330	Metal Film Resistor 3.3K		
240	420000 HK 356820	Carbon Resistor 8.2K		
241	420000 HK 356100	-do.- 1K		
242	420000 HK 356100	-do.- 1K		
243	420000 HK 356330	-do.- 3.3K		
244	420000 HU 576330	Metal Film Resistor 3.3K		
245	420000 HK 356330	Carbon Resistor 3.3K		
246	420000 HK 356270	-do.- 2.7K		
247	420000 HK 356100	-do.- 1K		
248	420000 HK 355470	-do.- 470		
249	420000 HK 355470	-do.- 470		
250	420000 HK 357470	-do.- 47K		
251	420000 HK 355100	-do.- 100		
VR202	420000 HT 410020	Variable Resistor 1K		
203	420000 HT 410020	-do.- 1K		
205	420000 HY 000190	Variable Resistor (Metal Grazed) 1K		
206	420000 HT 410060	Variable Resistor 6.8K		
C201	420000 FP 146330	Tantalum Capacitor 3.3 μ F 25V		
202	420000 FP 146330	-do.- 3.3 μ F 25V		
203	420000 FJ 245470	Electrolytic Capacitor 0.47 μ F 25V		
204	420000 FA 153470	Mylar Capacitor 0.0047 μ F 50V		
205	420000 FA 155100	-do.- 0.1 μ F 50V		
206	420000 FJ 245470	Electrolytic Capacitor 0.47 μ F 25V		
207	420000 FG 112470	Ceramic Capacitor 470pF 50WV		
208	420000 FG 112470	-do.- 470pF		
209	420000 FG 244100	-do.- 0.01 μ F		
210	420000 FJ 157100	Electrolytic Capacitor 10 μ F 35V		
211	420000 FJ 157100	-do.- 10 μ F 35V		
212	420000 FJ 157100	-do.- 10 μ F 35V		
	420000 KC 000240	Relay AE5344 NR DC24V		
	420000 LA 002110	Lapping Pin Type I 2P P=5		
	420000 LA 002120	-do.- 3P P=5		
	420000 LA 002030	-do.- 4P P=5		
	420000 LA 002040	-do.- 5P P=5		
76	320000 NA 069740	PL C.Board		
TR301	420000 i C 046080	Transistor 2SC460 B,C		
302	420000 i C 046080	-do.- 2SC460 B,C		
303	420000 i A 084400	-do.- 2SA844		
304	420000 i A 084400	-do.- 2SA844		
305	420000 i A 084400	-do.- 2SA844		
IC301	420000 i G 002390	IC YM27500		
Xtal	420000 QU 000100	Crystal HC18/U 4.32MHz		
D301	420000 i F 000190	Zener Diode WZ090		

Ref. No.	Part No.	Description	Markets	Remarks
R301	420000:HK 35:72:20	Carbon Resistor 22k Ω		
302	420000:HK 35:72:20	-do.- 22k Ω		
303	420000:HK 35:61:00	-do.- 1k Ω		
304	420000:HK 35:61:00	-do.- 1k Ω		
305	420000:HK 35:76:80	-do.- 68k Ω		
306	420000:HK 35:61:00	-do.- 1k Ω		
307	420000:HK 35:71:00	-do.- 10k Ω		
308	420000:HK 35:71:00	-do.- 10k Ω		
309	420000:HK 35:74:70	-do.- 47k Ω		
310	420000:HK 35:71:00	-do.- 10k Ω		
311	420000:HK 35:71:00	-do.- 10k Ω		
312	420000:HK 35:71:00	-do.- 10k Ω		
313	420000:HK 35:71:00	-do.- 10k Ω		
314	420000:HK 35:74:70	-do.- 47k Ω		
315	420000:HK 35:74:70	-do.- 47k Ω		
316	420000:HK 35:71:00	-do.- 10k Ω		
317	420000:HK 35:71:00	-do.- 10k Ω		
318	420000:HK 35:71:00	-do.- 10k Ω		
C301	420000:F D 15:21:00	Polystyrene Capacitor 100pF		
302	420000:F G 21:22:20	Ceramic Capacitor 220pF		
303	420000:F G 21:24:70	-do.- 470pF		
304	420000:F G 21:13:30	-do.- 33pF		
305	420000:F G 24:41:00	-do.- 0.01 μ F		
306	420000:F G 24:41:00	-do.- 0.01 μ F		
307	420000:F G 24:41:00	-do.- 0.01 μ F		
308	420000:F G 24:41:00	-do.- 0.01 μ F		
309	420000:F G 24:31:00	-do.- 1000pF		
310	420000:F G 24:31:00	-do.- 1000pF		
311	420000:F G 24:41:00	-do.- 0.01 μ F		
312	420000:F G 24:41:00	-do.- 0.01 μ F		
L301	420000:GE 30:01:20	Rf Inductor Coil 100 μ H		
302	420000:GE 30:01:20	-do.- 100 μ H		
303	420000:GE 30:01:20	-do.- 100 μ H		
304	420000:GE 30:01:20	-do.- 100 μ H		
305	420000:GE 30:01:20	-do.- 100 μ H		
	420000:LA 00:20:30	Lapping Pin Type I 4P P=5		
	420000:LA 00:20:50	-do.- 7P P=5		
77	320000:NA 06:97:50	LED C.Board		
	420000:i F 00:04:90	LED SLP-119B		
78	320000:NA 06:97:60	DET C.Board		
	420000:i F 00:08:90	LED TLR-106		
	420000:i K 00:01:70	Cds MKB-7H69		
	320000:CB 08:02:10	Lamp Holder		

POSITIONING OF THE SUB-TONEARM

■ FINE ADJUSTMENT

This fine adjustment can be made by regulating voltage between terminals of CDS and 1+ on the Control circuit board. After completion of setting VR206 (see Item "Electrical Adjustment—Control Circuit Board Adjustment").

Position the stylus-tip of the tonearm at distance of 53.2mm (2-3/32 in.) from the center shaft, which is just on the finishing concentric groove of the record, and also indicated on a template provided.

Here, fully turn clockwise the fine adjustment screw for positioning the sub-tonearm assembly, then turn it counter-clockwise until voltage between CDS and 1+ becomes 5.0±0.1 volt, using a voltmeter with input impedance of not less than 100kΩ. REFER TO 5 PAGE

回転アームAss'y位置調整

■微調整（最終溝位置調整）

微調整は、コントロールシート、CdS、1+端子の電圧を測定しながら行ないます。VR206（シート調整の項参照）のセッティングが完了したのち、トーンアームを移動し、針先位置がセンターシャフトから53.2mmにしたとき、回転アーム Ass'y 位置微調整ネジを右（時計方向）に回わしきった状態から、左（反時計方向）に回わしていき、CdS、1+端子間の電圧（入力インピーダンス100KΩ以上の電圧計使用）が、5.0±0.1Vになるようにします。本文5ページ参照

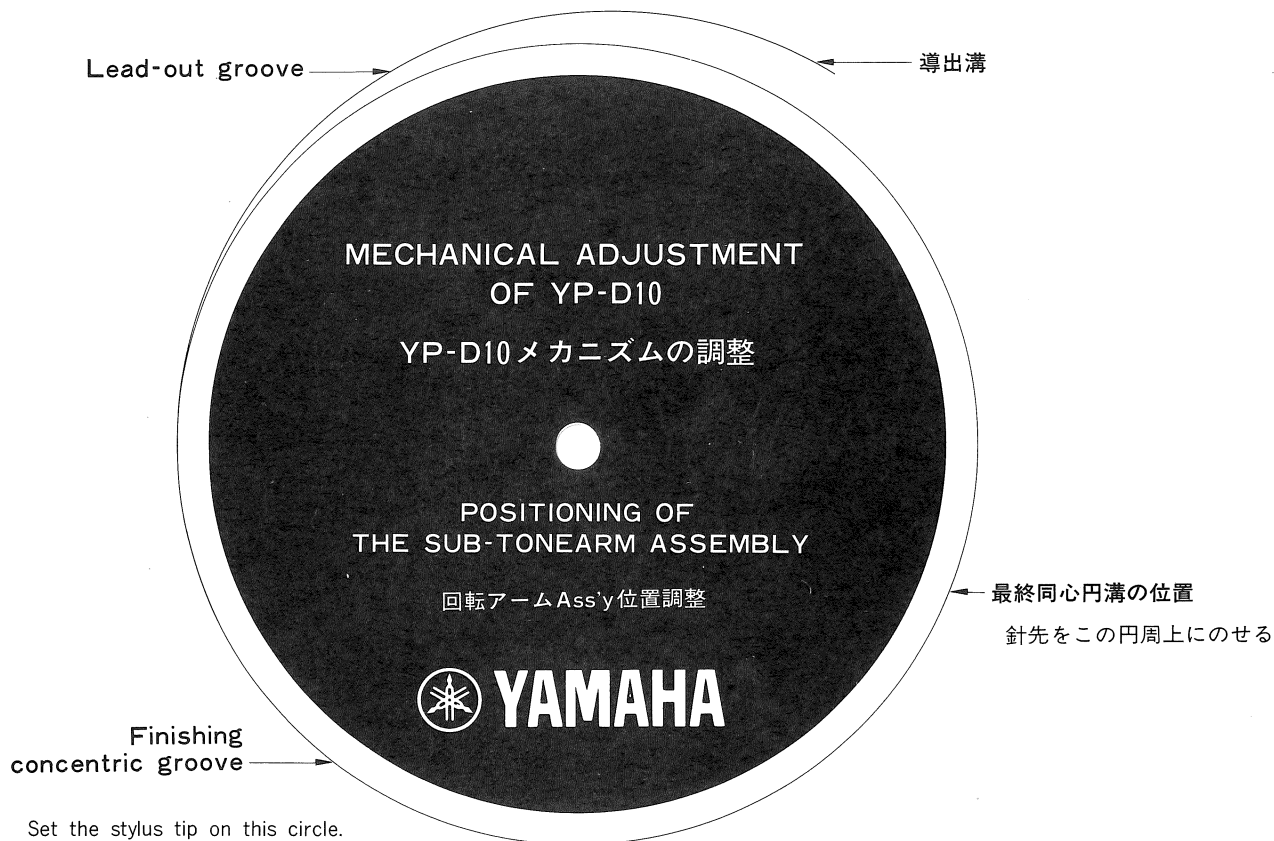

Set the stylus tip on this circle.

