



YAMAHA

AM/FM STEREO TUNER

T-1

OWNER'S MANUAL

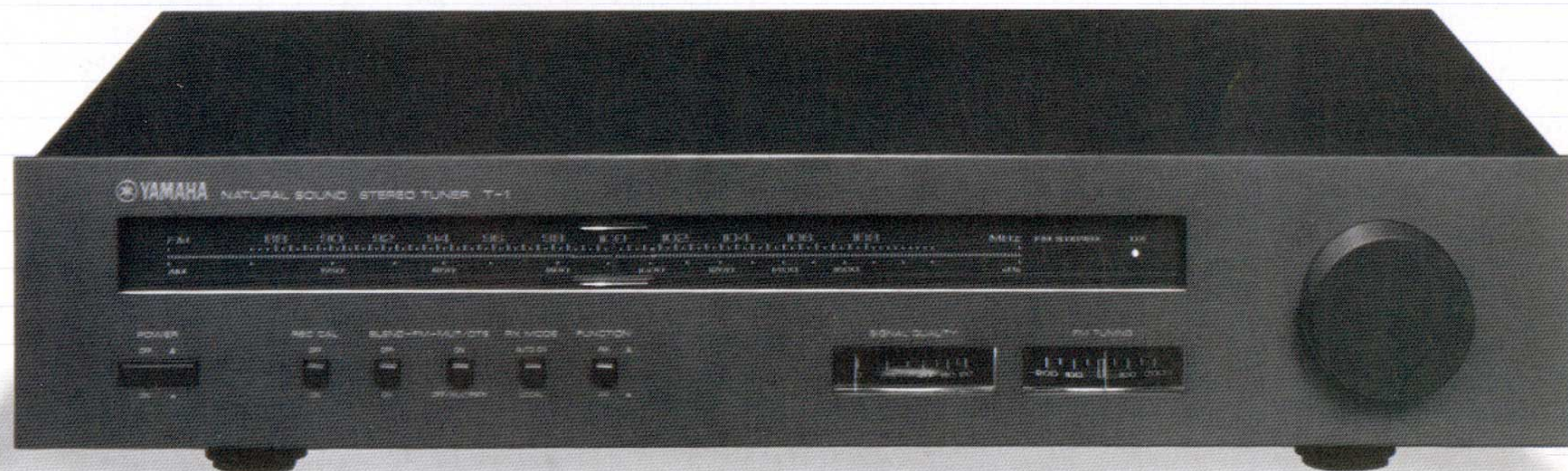

Thank you for your purchase of this new Yamaha T-1 AM/FM Stereo Tuner. You will find it to be the product of the most sophisticated Yamaha research and technology which continually attempts to make the best possible audio performance available to the widest range of enthusiasts. To make the most of the outstanding performance features of this tuner, you are encouraged to thoroughly familiarize yourself with the operating instructions in these pages.

FEATURES

- The front end is equipped with a dual-gate MOS, FET and FM 4-gang frequency linear variable capacitor, and the interstage double tune construction and IF stage with AUTO DX circuit make for excellent interference suppression characteristics.
- The IF stage with 7-stage current limiter features direct readout of differential gain and, thanks to the newly developed AUTO DX circuit, enables high quality reception with low distortion in any signal area. It also retains 60dB selectivity on local and provides a wider range of sound regeneration.
- This Yamaha-developed DC-NFB-PLL-MPX circuit with the new-type complete pilot cancellation circuit keeps MPX distortion under 0.003% and insures high-performance across a wide reproduction range (SN ratio of 100dB, DC-18kHz).
- A signal quality meter detects interference and following the tuning a built-in optimum tuning system (OTS) automatically "locks" local oscillator's frequency precisely into the right wave frequency. The tuning indicator lights up brightly when tuning is done and operates as the station indicator dial, these features make tuning utterly easy and accurate.
- Also engineered especially for greater tonal quality, the AM section features an RF 1 stage with three-gang frequency linear variable capacitor, differential mixer circuit, IF stage with ceramic filters – all of which insure great sensitivity, a fine dynamic range, minimal spurious response and low distortion.
The combination signal input system enables extremely sensitive AM reception with outdoor FM antenna.
- The excellent touch and extra-slim design make this Yamaha T-1 Tuner a real value-for-money audio product.

CONTENTS

Features	2
Caution: Read This Before Operating	
Your T-1	3
Connection Diagram	4
Connections	5
Connecting an FM(AM) Antenna	5
Connecting to a Stereo Amplifier	5
Connecting to a Tape Deck	5
Names and Functioning of Components	6
Rear Panel	6
Front Panel	7
Broadcast Reception	9
FM Reception	9
AM Reception	9
RX MODE Switch	10
REC CAL Switch	10
Multipath Detection	10
Circuit Explanation	11
Performance Graphs	13
Block Diagram	16
Schematic Diagram	17
Specifications	18
Troubleshooting	19

Special Instructions for British-Standard Model

IMPORTANT

THE WIRES IN THE MAINS LEAD ARE COLOURED IN ACCORDANCE WITH THE FOLLOWING CODE:

BLUE: NEUTRAL
BROWN: LIVE

As the colours of the wires in the mains lead of this apparatus may not correspond with the coloured markings identifying the terminals in your plug, proceed as follows. The wire which is coloured BLUE must be connected to the terminal which is marked with the letter N or coloured BLACK. The wire which is coloured BROWN must be connected to the terminal which is marked with the letter L or coloured RED.

CAUTION: READ THIS BEFORE OPERATING YOUR T-1**1**

The T-1 is a high performance AM/FM stereo tuner with excellent selectivity, sensitivity, and several special features. This manual is required reading if you are to get the best from it.

2

Do not drop or otherwise jar the T-1 which is a precision instrument.

3

Do not place the T-1 where it will be exposed to direct sunlight, excessive heat (for instance over a radiator or on top of an amplifier which generates a fair amount of heat), moisture, or dust.

4

Do not use chemical solvents (such as benzene or alcohol) to remove traces of dirt. Wipe only with a soft, slightly damp cloth.

5

Do not attempt to carry out internal adjustments or repairs. Leave this to your local service representative.

6

Do not assume your T-1 is faulty before checking the 'Trouble Shooting' list on page 19 for common operating errors.

7

Operate all switches and knobs in accordance with the instructions. Avoid applying undue force, which should never be necessary, and do not attempt to use intermediate settings.

8

Keep this manual in a safe place for future reference, and refer to it frequently until you are perfectly familiar with all T-1 controls and functions.

9

If your T-1 has a voltage selector, check that it is set to your local voltage before you plug in the AC supply.

If not properly set, unscrew the two switch-guard retaining screws, and reset the switch to indicate your supply voltage (110–130V, or 220–240V).

After setting the voltage selector switch to your local mains voltage, fit the switch guard and fix it with two retaining screws.

(European and General models only.)

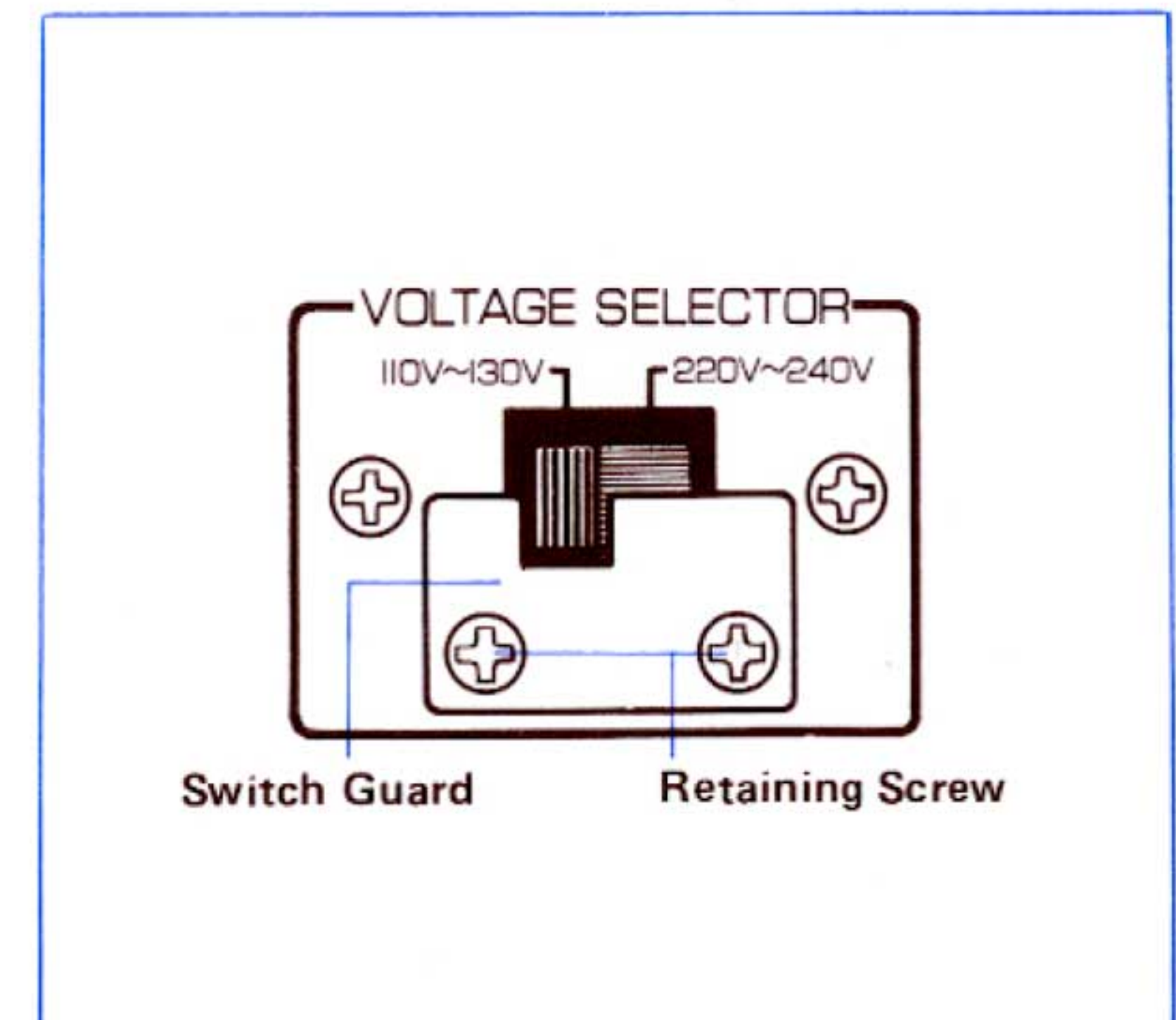

CONNECTION DIAGRAM

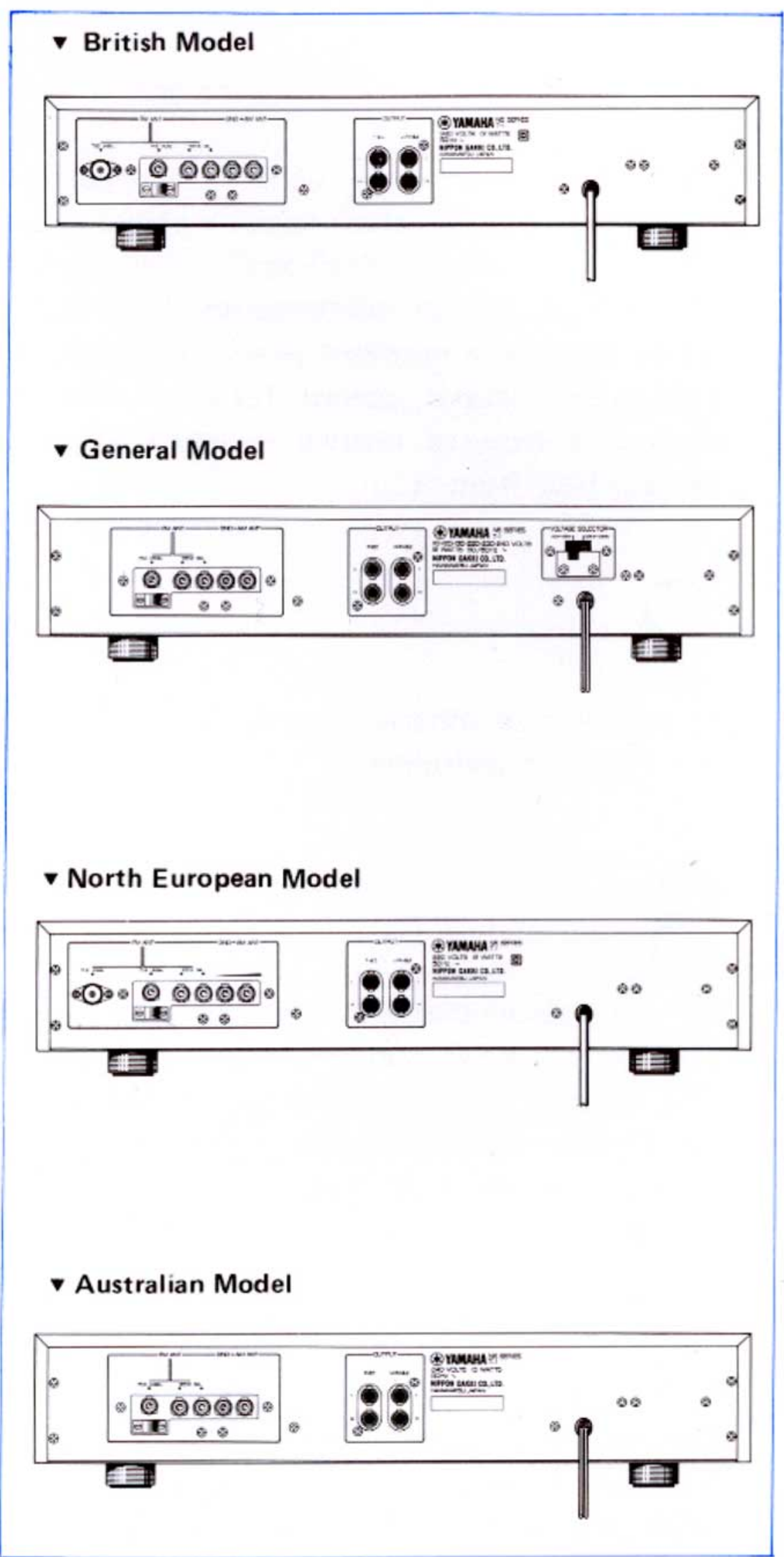
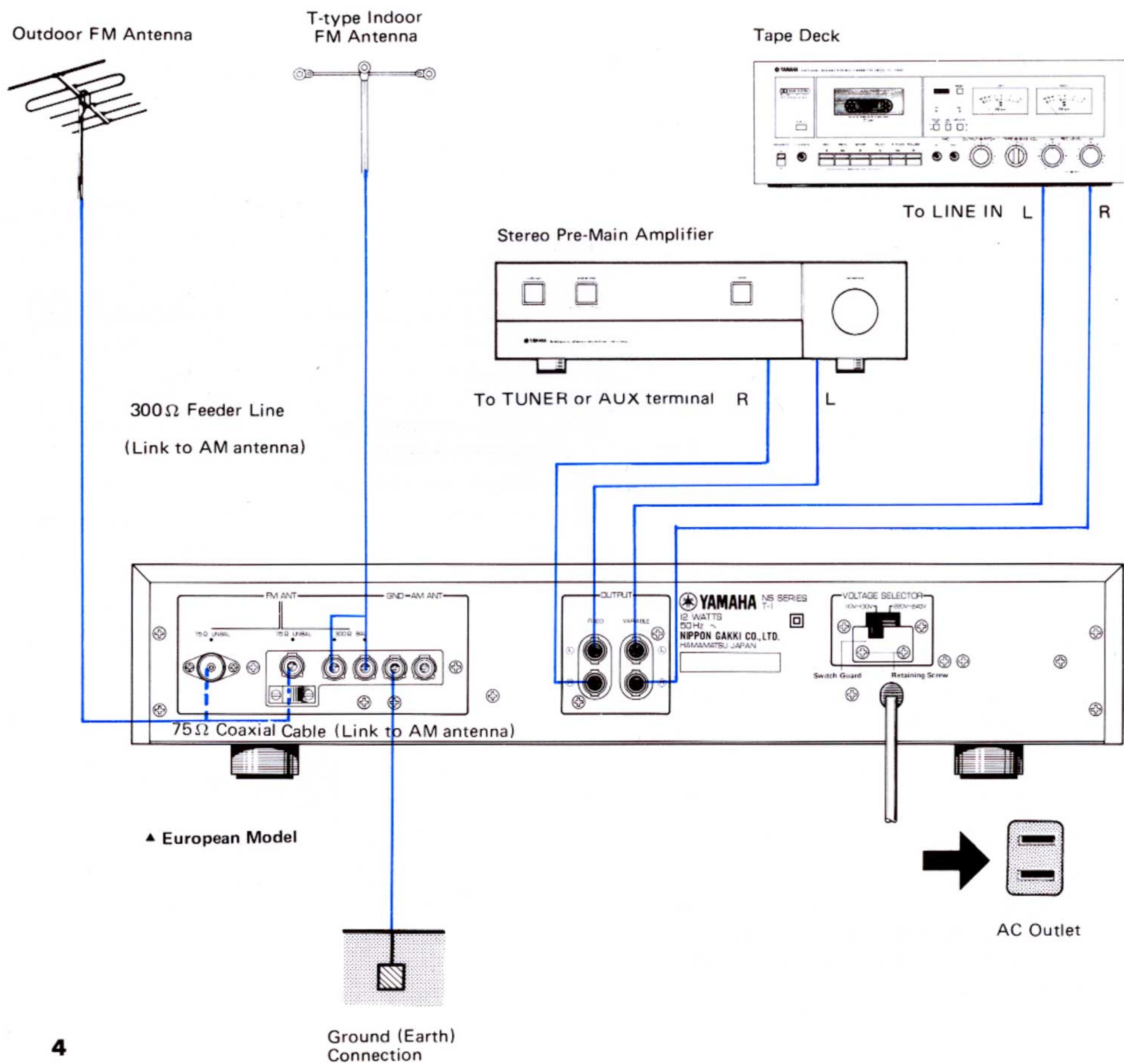

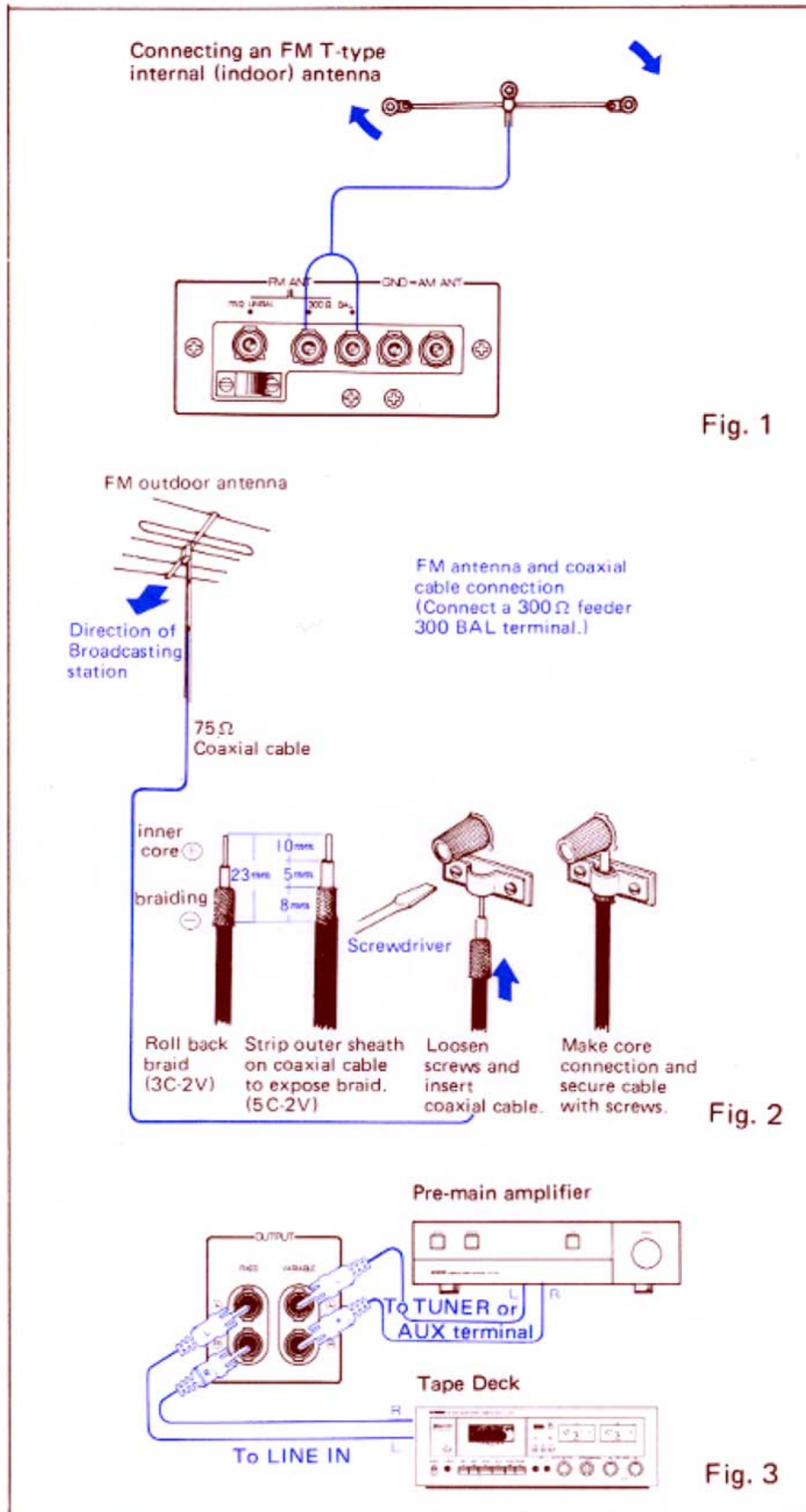

CONNECTING AN FM (AM) ANTENNA

The T-1 Tuner uses an FM antenna for AM as well as FM reception, so always install an FM antenna – even when you want AM broadcast reception.

* Since FM (AM) reception will differ in terms of conditions in the area (buildings, mountains, etc.), select your antenna in terms of signal strength. (Refer to page 9 for more details on reception.)

1 T-TYPE INTERNAL (INDOOR) ANTENNA

The T-type internal (indoor) antenna, which comes with the tuner itself, is for use in areas close to the broadcasting station where there is a strong signal.

(Use the T-type antenna or install an FM outdoor antenna for AM reception also.)

First, connect the feeder line of the T-type antenna to the rear panel FM300Ω BAL terminals (Fig. 1). Extend the two antenna arms horizontally to form a T, then slowly turn the T until you find the position at which reception is best. Secure the arms in that orientation by attaching to walls or ceiling.

2 FM (AM) OUTDOOR ANTENNA

If reception is unsatisfactory with the T-type internal (indoor) antenna, install an outdoor FM (AM) antenna (good for both FM and AM reception).

• An FM antenna may be connected to the 300 Ω and 75 Ω terminals on the rear panel. For an FM (AM) antenna, you may use either a 300 Ω balanced feeder or a 75 Ω coaxial cable. How-

ever, in areas in which there is much outside static from motorcycle or auto ignition noise, a 75 Ω coaxial cable (3C-2V or 5C-2V) is recommended.

- When connecting up a coaxial cable, be careful not to let the braiding and inner core contact one another so as to cause a short (see Fig. 2).

CONNECTING TO A STEREO AMPLIFIER

As shown in Fig. 3, use the pin-plug cables provided with the T-1 to connect the OUTPUT VARIABLE terminals to the TUNER (input) or AUX terminals on the amplifier.

CONNECTING TO A TAPE DECK

A tape deck can be hooked up directly to the tuner in order to record programs.

As shown in Fig. 3, the pin-plug cables from LINE IN terminals on the tape deck can be connected to the OUTPUT FIXED terminals on the tuner.

Precautions When Making Connections

- When connecting the T-1 OUTPUT terminals with the stereo amp or tape deck INPUT terminals, be sure to use the corresponding channel (matching L with L, and R with R).
- Pin-plugs should be carefully inserted all the way when making the connections, or there will be sound failure or static.
- Winding your input/output cord into a tight coil together with your power cord and/or speaker cord can cause ham interference or static.

REAR PANEL

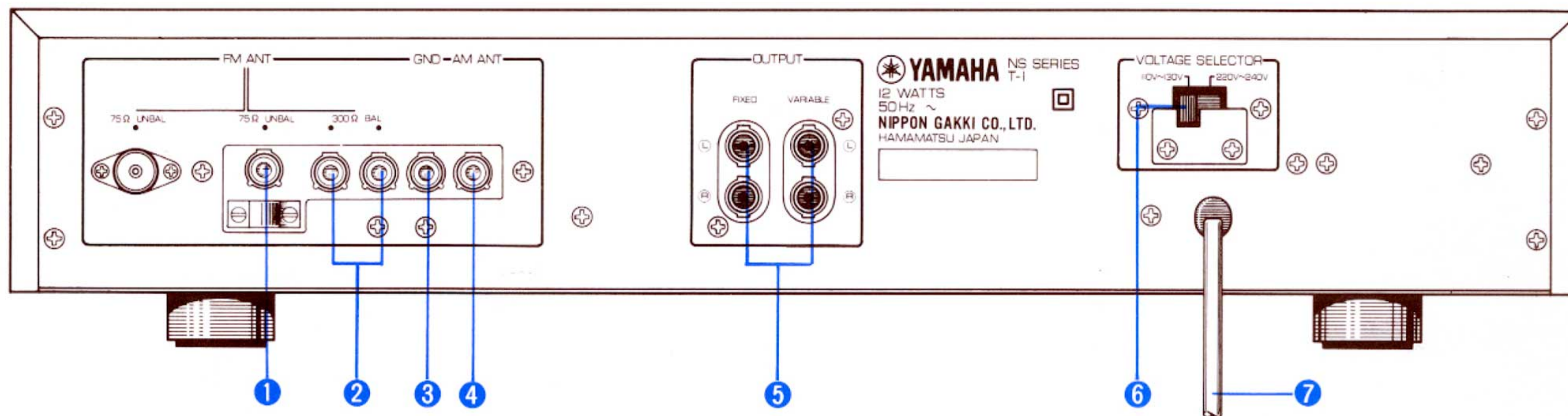

① FM ANT 75Ω UNBAL

(75Ω FM Antenna Terminal)

The 75Ω UNBAL (unbalanced) terminal is used for an unbalanced type 75Ω coaxial cable.

(Refer to p. 8.)

② FM ANT 300Ω BAL

(300Ω FM Antenna Terminal)

Use this terminal to connect a 300Ω balanced type feeder line.

(Refer to p. 8.)

③ GND (Ground Terminal)

This is your ground terminal. You are encouraged to ground the tuner for safety and the elimination of static during reception.

④ AM ANT (Terminal for AM Reception)

Since the FM antenna is used also for AM on the T-1, there is no need to use an AM antenna as long as you have installed an FM antenna and only long-distance reception is involved.

⑤ OUTPUT (Output Terminals)

The output terminals on the T-1 provide a fully variable signal for pre-main amplifiers or tape

decks. Use the pin-plugs to make the connection. The output of the FIXED terminal is constant. That of the VARIABLE terminals can be adjusted with the OUTPUT LEVEL control.

(Refer to p. 8.)

⑥ VOLTAGE SELECTOR

This must be set to your local AC mains voltage. Failure to do so will result in seriously impaired performance or even severe damage to your T-1. *(European and General models only)*

⑦ POWER SUPPLY CORD

Always plug into an AC receptacle or the spare AC OUTLET on an amplifier.

NAMES AND FUNCTIONS OF COMPONENTS

FRONT PANEL

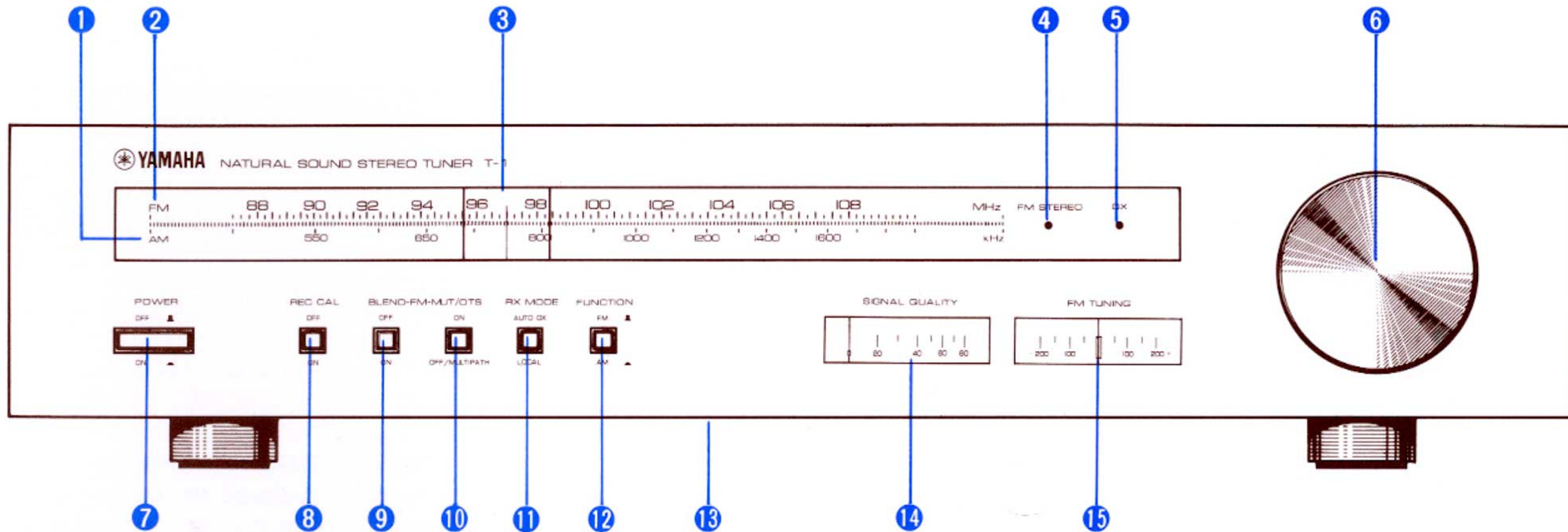

① AM Tuning Scale

The AM frequency indication is calibrated in kHz (kilohertz) units.

② FM Tuning Scale

The FM frequency indication is calibrated in MHz (megahertz) units.

③ Tuning Indicator

By turning the tuning knob, this indicator can be set to a given station frequency. The tuning indicator lamp grows brighter at the time the sound of a broadcast is picked up on the speaker. Thus it serves as a station indicator also (to ascertain current tuning).

④ FM STEREO (FM Stereo Indicator)

This indicator comes on automatically when FM stereo broadcasting is received; it goes out automatically when there is monoaural reception. (There is no lighting for monoaural reception.)

⑤ DX (DX Indicator)

If the DX indicator light is on when the RX MODE switch ⑪ is in the AUTO (■) DX position, it signifies that the tuner is operating in the DX MODE. During FM broadcasts in which there is tuning to a powerful local station, the LOCAL MODE takes over. (Refer to p. 10 for RX MODE switch.)

⑥ Tuning Knob

You can select the station by simply turning this knob. Clear, sharp reception can be obtained by watching the signal meter when tuning in AM and by checking both the signal meter and tuning meter for FM.

⑦ POWER Switch



When this switch is pressed in, the power supply comes ON (■); when it is depressed again, the power supply is turned OFF (■). (When the power supply is switched ON, the signal meter, FM tuning meter and tuning indicator light up.)

⑧ REC CAL (Recording Level Calibration Switch)



When this switch is pressed ON () the 333Hz (ca. 50% modulation) signal which determines the recording output level is sent from the OUTPUT terminals.

(Refer to p. 10 to REC CAL switch.)

⑨ FM BLEND Switch

In feeble reception areas, when a screeching or high-pitched noise makes for poor FM stereo reception, press ON () this switch. The blend circuit will cut in to eliminate the high-range noise completely. If the FM BLEND is switched OFF (), you can obtain better FM stereo separation in the higher ranges whenever there is strong signal.

⑩ FM MUT./OTS (FM Muting/OTS Switch)

With this switch ON (), you can reduce the background noise that appears when selecting FM broadcasting. However, in poor reception areas, the muting circuit activation may eliminate the weak station itself, so you are encouraged to put on the OFF/MULTIPATH switch when tuning in from a weak signal area. (In the OFF/MULTIPATH () position, FM Multipath detection is possible.

(Refer to p. 10 for multipath detection.)

⑪ RX MODE Switch

Use of the switch permits effective use of the T-1 AUTO DX circuit in order to tune in an AM or FM station.

● AUTO DX () Position



Set at this position for reception in areas with weak reception or much interference. The DX indicator will light up and reception will become more clear. When interference is less and antenna input is sufficient during reception, the DX indicator light goes out and the tuner is switched automatically to the LOCAL MODE. The DX indicator will light up when there is momentarily strong interference (from a passing vehicle, for example) or in the event of a temporarily weak signal. In this case you can retune with the tuning knob or switch to the LOCAL () position.

(Note: There is only DX operation during AM reception.)

● LOCAL () Position

In areas where AM or FM reception is sufficiently strong, switching to this position provides a wide range of reception with greater resolution.

⑫ FUNCTION Switch

- Set this switch to FM () for FM reception.
- Set this switch to AM () for AM reception.

⑬ OUTPUT LEVEL CONTROL

This dial permits you to adjust the output level of the rear panel OUTPUT VARIABLE terminals from 0.1 to 1 Vr.m.s (100% FM modulation). At the click stop in the center, the output level is 0.5 Vr.m.s.

(r.m.s. = root mean square)

⑭ SIGNAL QUALITY Meter

This meter indicates the quality (static, interference level) of the signal being received. When there is much interference the meter indicator will flutter, the amount of deviation reflecting the degree of interference.

* During FM reception, when the FM MUT./OTS switch is set to OFF/MULTIPATH (), the meter indicator flutter means multipath detection is in process. When the multipath has been detected, adjust in accordance with the multipath detection instructions on p. 10.

⑮ FM TUNING Meter

This is used when tuning in FM stations: the indicator points to dead center when the tuning knob is turned and the signal quality meter indicator moves to the right.

FM RECEPTION

- 1 Check the antenna and amp connections, then put on the power switch.
- 2 Set the front panel FUNCTION switch to the FM (■) position.
- 3 The FM MUT./OTS switch is usually on, and the RX MODE switch is set to the AUTO DX (■) position.

*The DX indicator lights up when the tuning is off at this time.

- 4 With the tuning knob, turn the tuning indicator approximately to the desired station. The indicator light grows brighter as you begin catching the station signal.

*When the signal you receive is sufficiently strong, the LOCAL MODE takes over and the DX indicator light goes out.

- 5 While referring to Fig. 4, tune in FM stations by turning the TUNING knob so that the TUNING meter indicator is placed at the center when that of the SIGNAL QUALITY meter deflects to the extreme right.

- 6 Change the orientation or position of the antenna so that there will be maximum deviation of the signal quality meter indicator when the tuning meter indicator points to dead center. (Fig. 4).

- 7 The FM STEREO indicator lights up when the station is broadcasting stereo. It goes out automatically in the case of monoaural. Adjust the output of the OUTPUT VARIABLE terminal by means of the OUTPUT LEVEL control. (Fig. 5)

* If it is difficult to tune in to a desired station because of interference from a closer station when you are far away in a poor reception area, set the FM MUT./OTS switch to the OFF/MULTIPATH (■) position and put the RX MODE switch on AUTO DX (■) to easily obtain good reception.

* When the AM/FM stations are both nearby and the signal is quite strong, set the RX MODE switch to the LOCAL (■) position for better quality sound.

AM RECEPTION

- 1 Set the front panel FUNCTION switch to the AM (■) position.
- 2 The RX MODE switch is usually set to AUTO DX (■).
- 3 Turn the tuning knob, aligning the indicator with the frequency.
- 4 The position at which there is maximum deflection of the signal quality meter is the optimal tuning point. (Fig. 4)

*The FM tuning meter does not work during AM reception.

- 5 Adjust the output of the OUTPUT VARIABLE terminal by means of the OUTPUT LEVEL control. (Fig. 5)

*Since the FM antenna you may have is also to be used for the T-1 AM antenna, no AM antenna is required. However, an outdoor AM antenna should be installed if you are located in an especially poor reception district. In this case you will obtain better reception if you also ground the AM antenna.

Reading SIGNAL QUALITY meter and TUNING meter

When there is an interference wave, the SIGNAL QUALITY meter indicator deflects as follows.

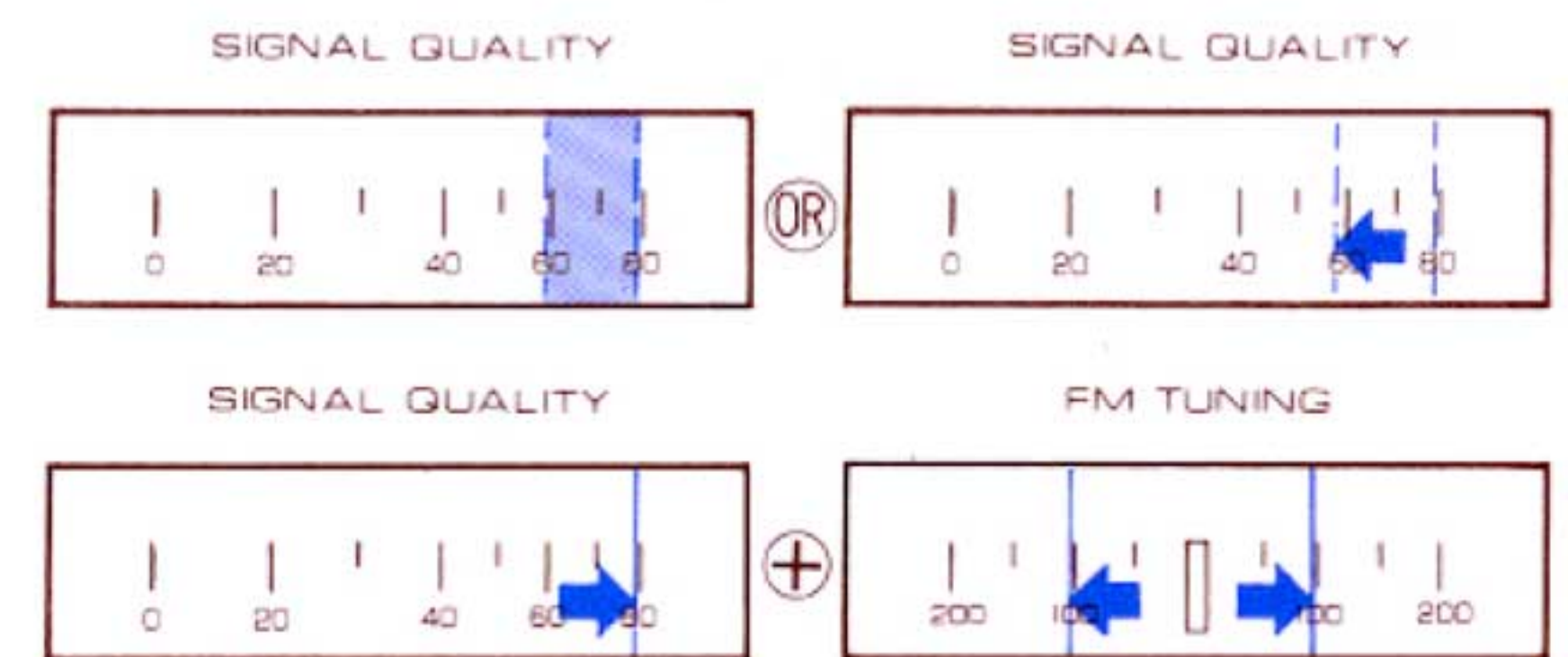

If the SIGNAL QUALITY meter indicator deflects to larger degree when the TUNING meter indicator is displaced from the center position than when it is in the center position, there is an interference wave. Adjust the direction and height of antenna so that the SIGNAL QUALITY meter indicator deflects to the extreme right with the TUNING meter indicator placed in the center.

When there is no interference wave:



Fig. 4

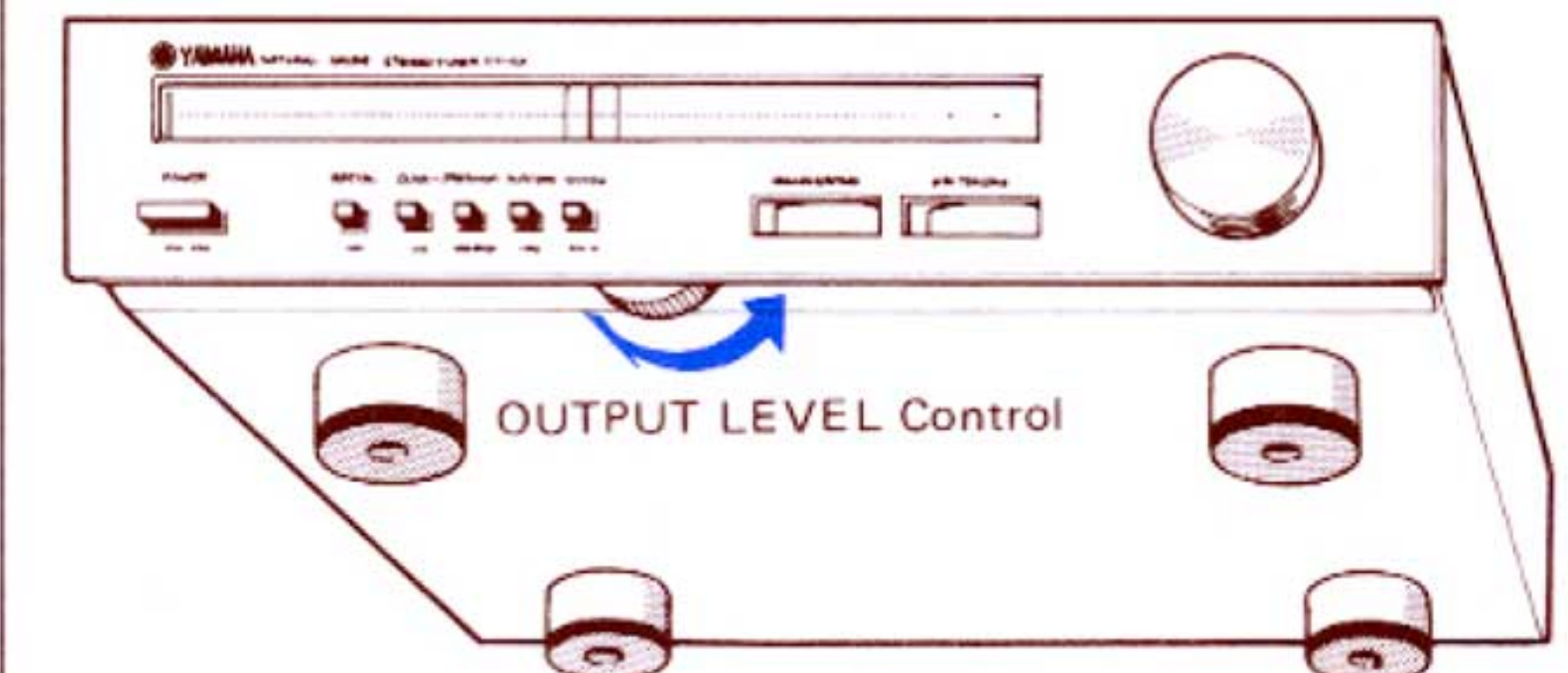

Fig. 5

RX MODE

AUTO DX



LOCAL

Fig. 6

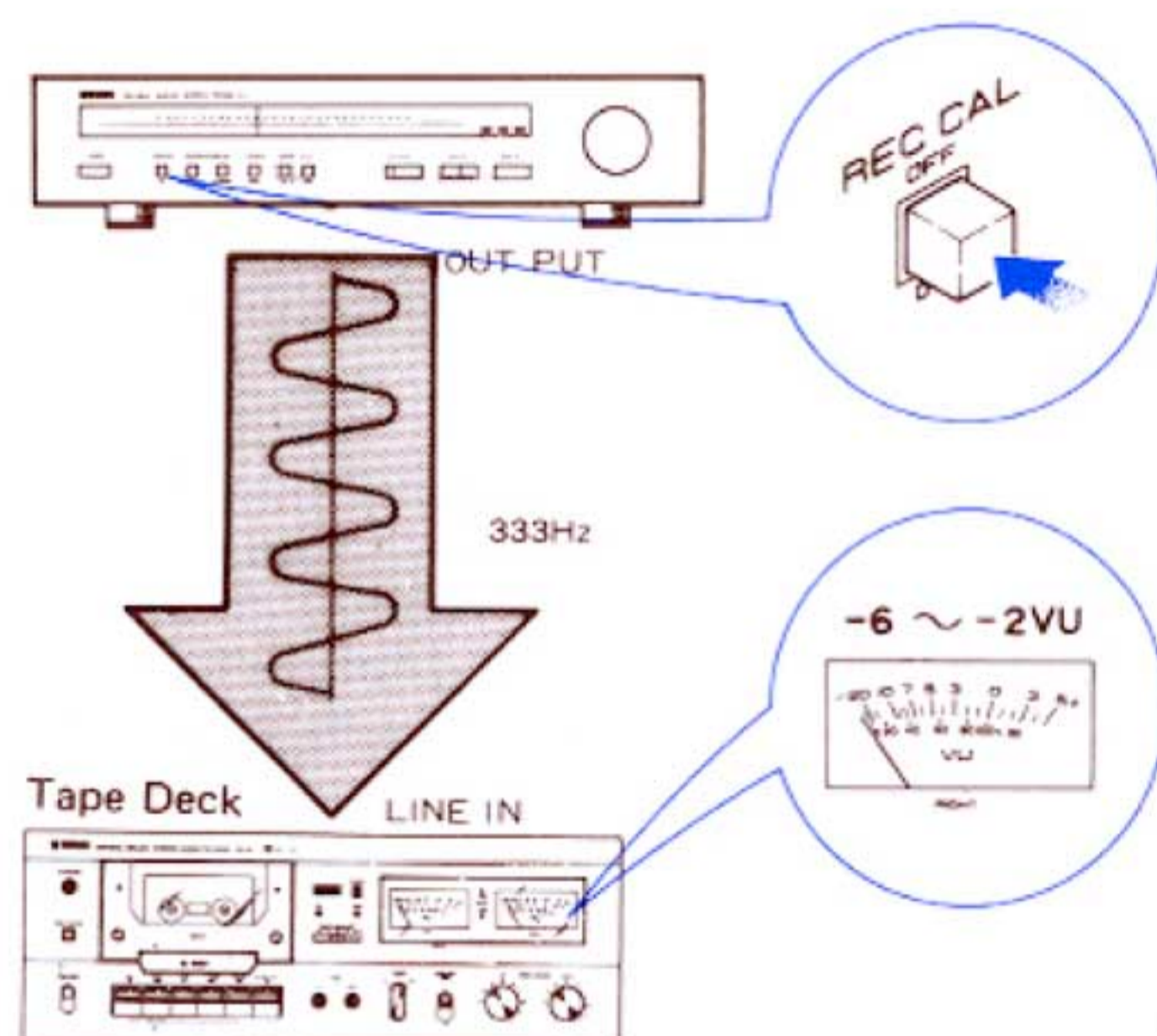

Fig. 7

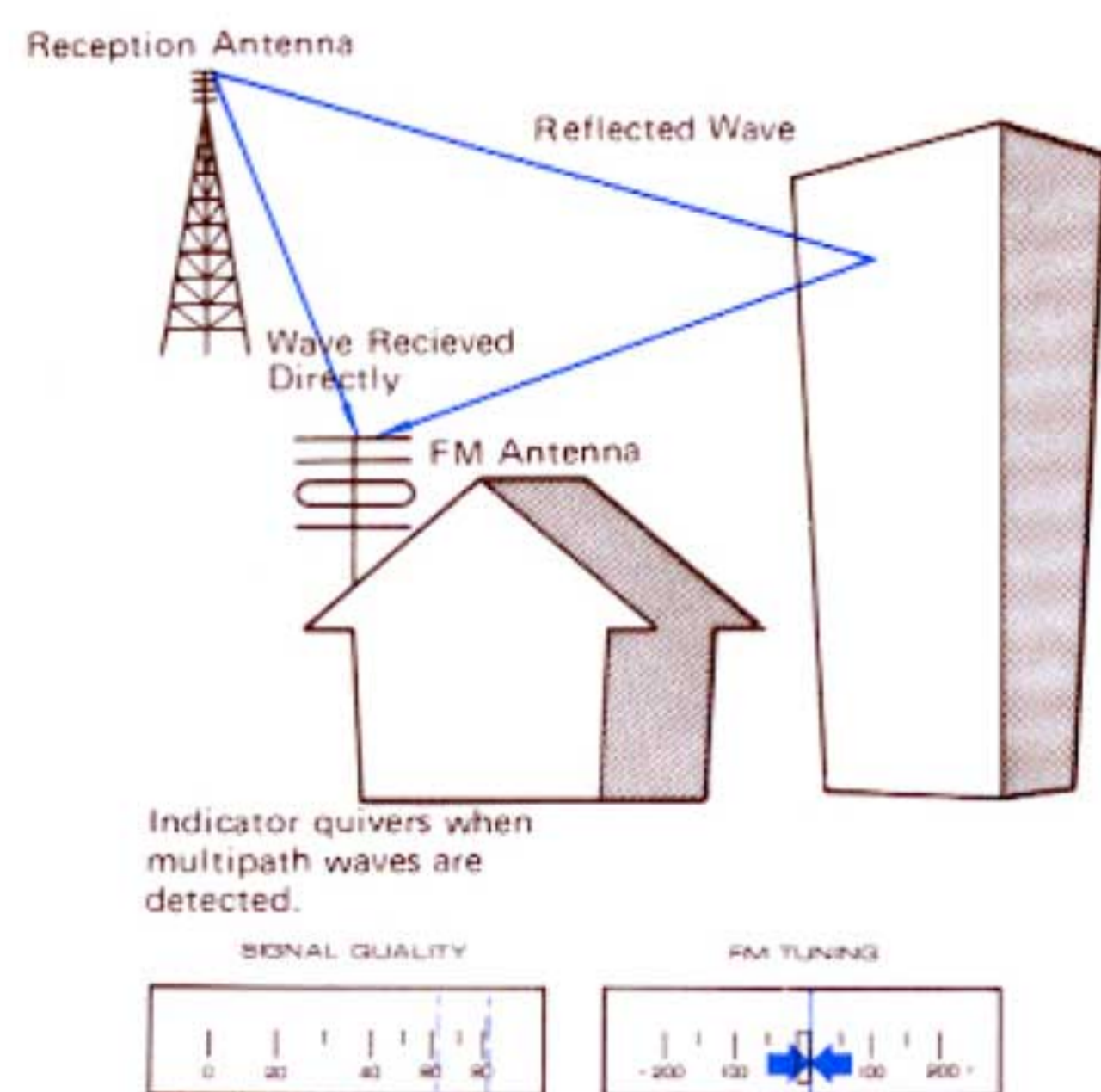

Fig. 8

RX MODE SWITCH

This T-1 switch (Fig. 6) enables you to obtain good reception in remote areas where there is considerable interference.

●AUTO DX (■) Position

In a poor AM or FM reception area or when there is interference from a nearby station, setting to the AUTO DX (■) position will automatically activate the DX MODE and its indicator light will come on. In the AUTO DX (■) position you get maximum suppression of interference as well as excellent sensitivity when listening to weak signals. When the station signal is sufficiently strong, the T-1 automatically switches to LOCAL MODE for a wider range of reception with minimal distortion and excellent quality sound.

* There is only DX operation during AM reception.

●LOCAL (■) Position

Set to this position whenever there is sufficiently large antenna input and only slight interference with reception. The low distortion characteristic takes over and you obtain crystal clear sound of very high resolution.

* In remote areas with poor reception, you are encouraged to set to the AUTO DX (■) position.

REC CAL SWITCH

A suitable sound level is essential if you hope to obtain good sound quality when recording FM broadcasts. Press on the REC CAL switch for an OUTPUT terminal signal of 333 Hz (50% modulation). When the tape deck is connected up, you can thus obtain a suitable recording level at all times

irrespective of the program (Fig. 7). When setting for the right recording level, adjust either the T-1 OUTPUT LEVEL control or the deck LINE INPUT level control to the values indicated in the table below.

Tape Used	Setting Level By REC CAL
CrO2 tape	-6VU
LH tape	-4VU
FeCr type	-2VU

* The above values are only a rule of thumb. The actual value may differ in terms of the tape deck or FM modulation.

* If you switch off the power in the REC CAL (■) position, a certain amount of signal sound remains.

MULTIPATH DETECTION

FM multipath is somewhat like the TV "ghost" phenomenon. As shown in Fig. 8, some FM signals are received directly by the antenna while others reach it from many directions, bouncing off buildings or mountains. The latter are called multipath waves. These are received only slightly later than the direct waves, and this causes some sound distortion, separation and deterioration in tonal quality. This multipath effect can be prevented by using a tall antenna with good directional characteristics and by installing it after careful study to obtain the right orientation so as to eliminate interference.

Multipath Detection

During FM reception, a delicate quiver of the signal meter indicator when the FM MUT./OTS switch is set to OFF/MULTIPATH (■) indicates multipath interference. Change your antenna orientation or position so that the indicator stabilizes.

1. FRONT END

The front end provides outstanding interference suppression characteristics, thanks to its dual-gate MOS FET and FM 4-gang frequency linear variable control in team with the superb IF stage with inter-stage double tune construction.

2. IF (Intermediate Frequency Amplification) STAGE

To insure high quality reception in any signal conditions, the T-1 is equipped with an AUTO DX circuit which checks the quality of waves received and automatically switches to the IF band. In relatively mild interference conditions, the LOCAL position can provide outstanding audio performance characteristics. The IF stage features direct

readout of differential gain, incorporates two ceramic filters and an IF amplifier with a 7-stage current limiter and buffer amps. The outstanding transmission characteristics of the IF block filters guarantee sufficient tuning selectivity in ordinary (55dB) areas, in districts where there is much interference, the use of the DX position for fine reception assures effective tuning at 92dB, thanks to the addition of four low-spurious type ceramic filters to check transmission characteristics by the direct readout of differential gain. This AUTO DX circuit detects interference through an interference detection circuit and switches to the IF band by means of a transistorized switching system. Like the IF stage, the discriminator also has the direct assessment of differential gain feature with

an analyzed wide-band balanced type of ratio detector that insures extremely low distortion.

Direct Readout of Differential Gain

The problem in FM reception is that, in improving interference suppression characteristics by finer tuning, more distortion and less fidelity results. Yamaha has pioneered a unique system that provides direct readout of differential gain in order to sophisticate tuning and prevent distortion or separation. This technique enables readout of the amplitude conversion gain in terms of microwave frequency deviation in the stereo signal transmission system; the needed tuning selectivity is maintained and the differential gain is minimized so that excellent audio performance results.

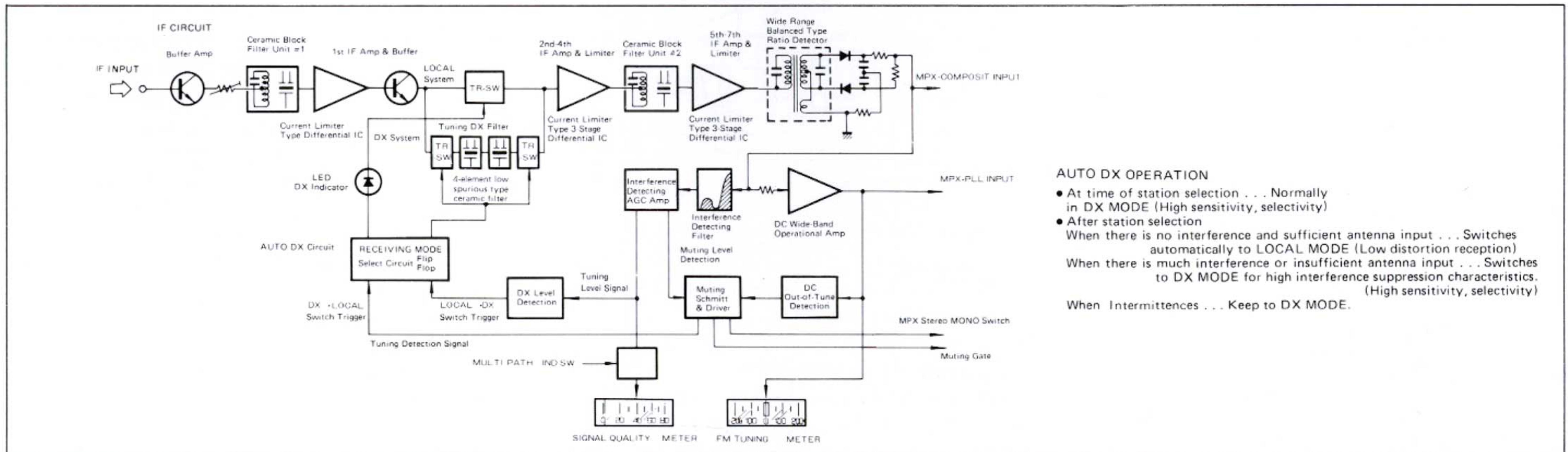

AUTO DX OPERATION

- At time of station selection . . . Normally in DX MODE (High sensitivity, selectivity)
- After station selection
 - When there is no interference and sufficient antenna input . . . Switches automatically to LOCAL MODE (Low distortion reception)
 - When there is much interference or insufficient antenna input . . . Switches to DX MODE for high interference suppression characteristics. (High sensitivity, selectivity)
- When Intermittences . . . Keep to DX MODE.

3. DC·NFB·PLL·MPX CIRCUITS

In order to switch and demodulate stereo composite signal with the 38 kHz subcarrier of MPX circuit, the intermodulation distortion in the circuit must be diminished. This is because the switched composite signal has a frequency components more than 1 MHz from DC. Thus, the T-1 MPX circuit features an original DC-NFB switching circuit based on a high through rate DC amplifier. An interference suppression filter has been added to the phase locked loop (PLL) for subcarrier generation, and there is a built-in anti-interference PLL system to virtually eliminate disturbance from stereo sound signals. Moreover, using the 19kHz generated by the PLL, a 19kHz signal is regenera-

ted in accordance with the input pilot signal level and the phase. And since passage is through a wave conversion circuit, the pilot signal can be cancelled at the switching circuit input point almost perfectly in accordance with the wave configuration, level and phase. Thanks to this tracking type pilot perfect cancellation operation, a 19kHz pilot signal (not needed for a multiplex signal stereo decoder) is not incorporated. Only pure composite signals are regenerated. As a result, an MPX demodulation system with extremely small discoloration from mixed modulation is used, and the following low-pass filter cutoff frequency can be kept at over 19 kHz. This provides a virtually flat regenerative frequency characteristic up to 18kHz.

4. METERS AND MUTING SYSTEM

The signal meter is an interference detection type which indicates the signal quality (almost all S/N for stereo). There is faster time constant setting with the MUTING/OTS SW OFF POSITION, and the multipath fading interference can be easily detected. The muting system features extremely acute error detection, incorporating a Schmitt circuit to pick up off-tune and interference signals. Driven gates are equipped at each stage before and after the active load emitter follower buffers (2-stage symmetric gate muting circuit). There is also a timing circuit for power ON and OFF, and muting is performed.

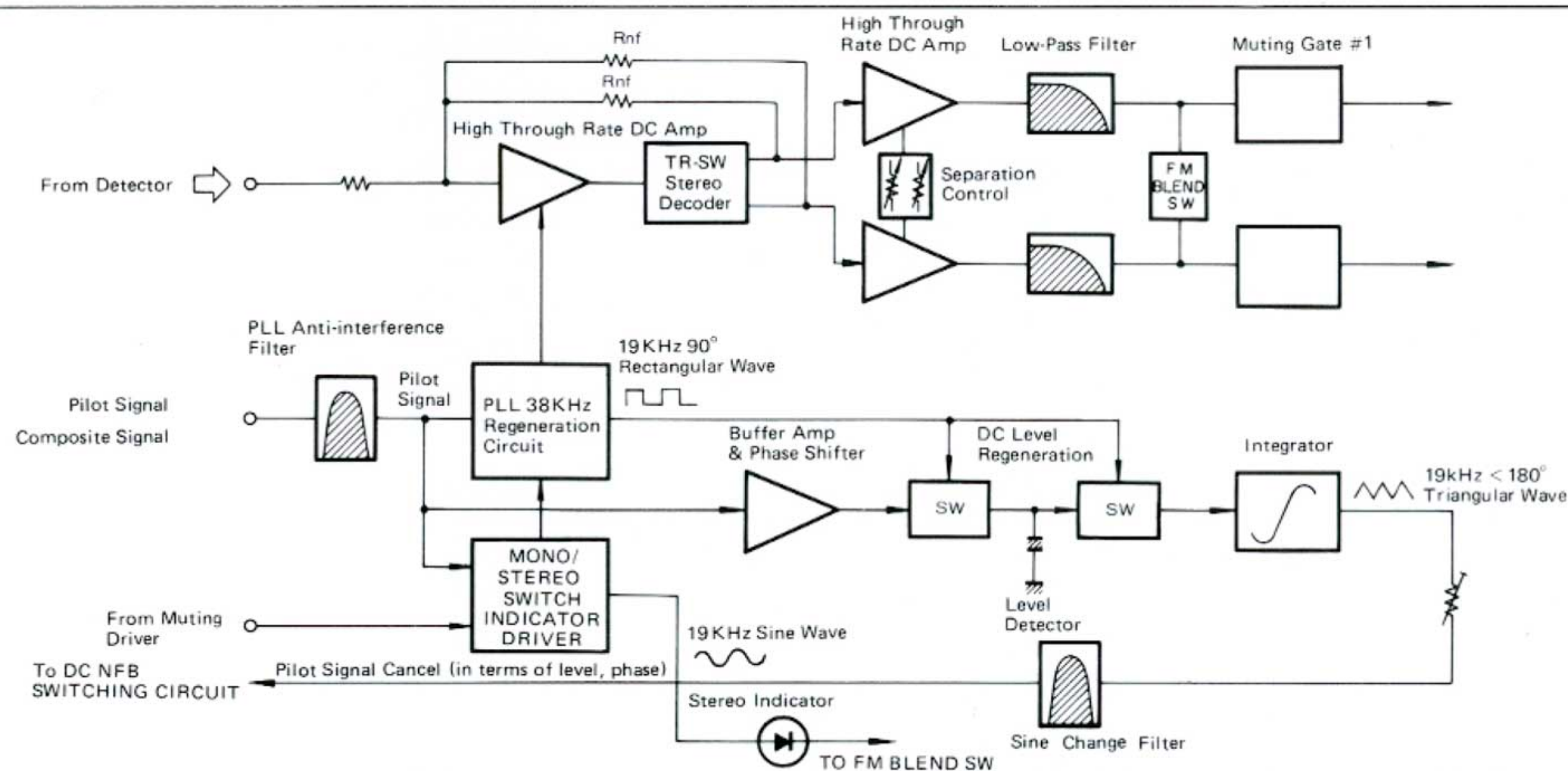

Output And Noise Level Characteristics In Terms Of Antenna Input Level

- The output signal curve remains uniform once the antenna input level is over 10dBf. In the range from 10 to 120dBf (approx. 1 volt), distortion increases when there is variation in level, but with the T-1 there is a flat characteristic even with variation in the antenna input.
- As to the noise level curves, the SN ratio is below 85dB for both stereo and monoaural among antenna input signal level curves, which makes for crystal-clear sound of extremely high tonal quality.
- The muting operation level is 5 μ V. Since no inputs lower than this are received, unpleasant station noise is effectively eliminated.

■ Output/Noise Level vs. Antenna Input Level

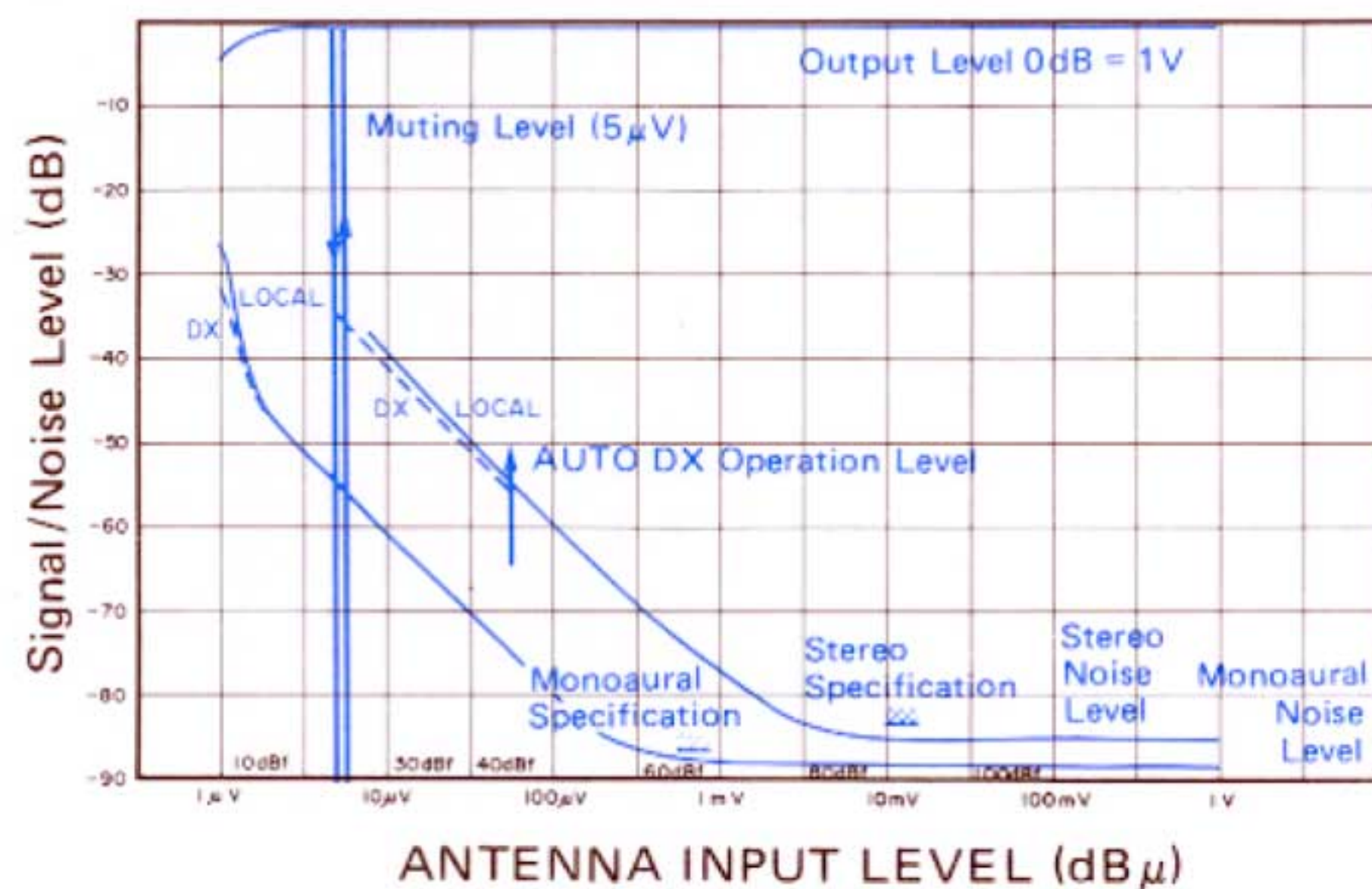

Total Harmonic Distortion Characteristics In Terms Of Antenna Input Level

- The graph indicates the stereo and monoaural distortion characteristics in terms of antenna input signal level. The actual IHF sensitivity of the monoaural curve is seen to have a total harmonic distortion of less than 3 percent.
- Even should the antenna input level become high, it is still less than 0.05% on the T-1. With the low antenna input level, the relative stereo (as compared to monoaural) distortion can be attributed to insufficient S/N.

■ Antenna Input Level vs. Total Harmonic Distortion

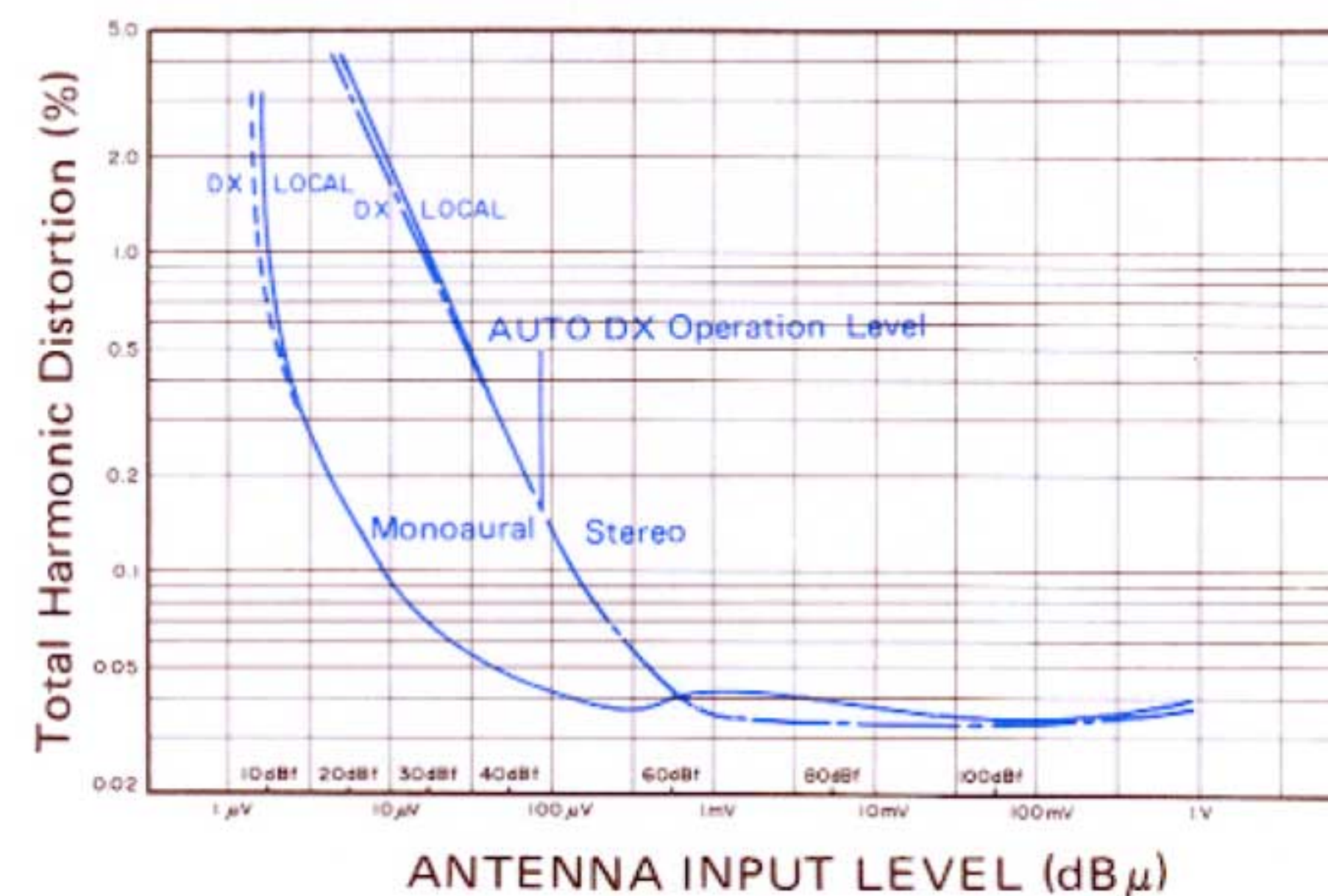

Effect Of Mistuning On Distortion

- It is impossible to obtain good FM reception with a tuner on which a very slight mistuning results in sudden distortion. The T-1 OTS system circuitry is engineered so that a setting which is just slightly off the optimal tuning point will not result in distortion. (Distortion is less than 0.05% when the tuning meter indicator is on the center marking.)
- Since stereo requires a broader range than monoaural, mis-tuning greatly increases distortion and more precise tuning is required. When the OTS circuit is activated (ON curve), however, the range is sufficient and the distortion rate is seen to be low.

■ Distortion, Mistuning And OTS Effect

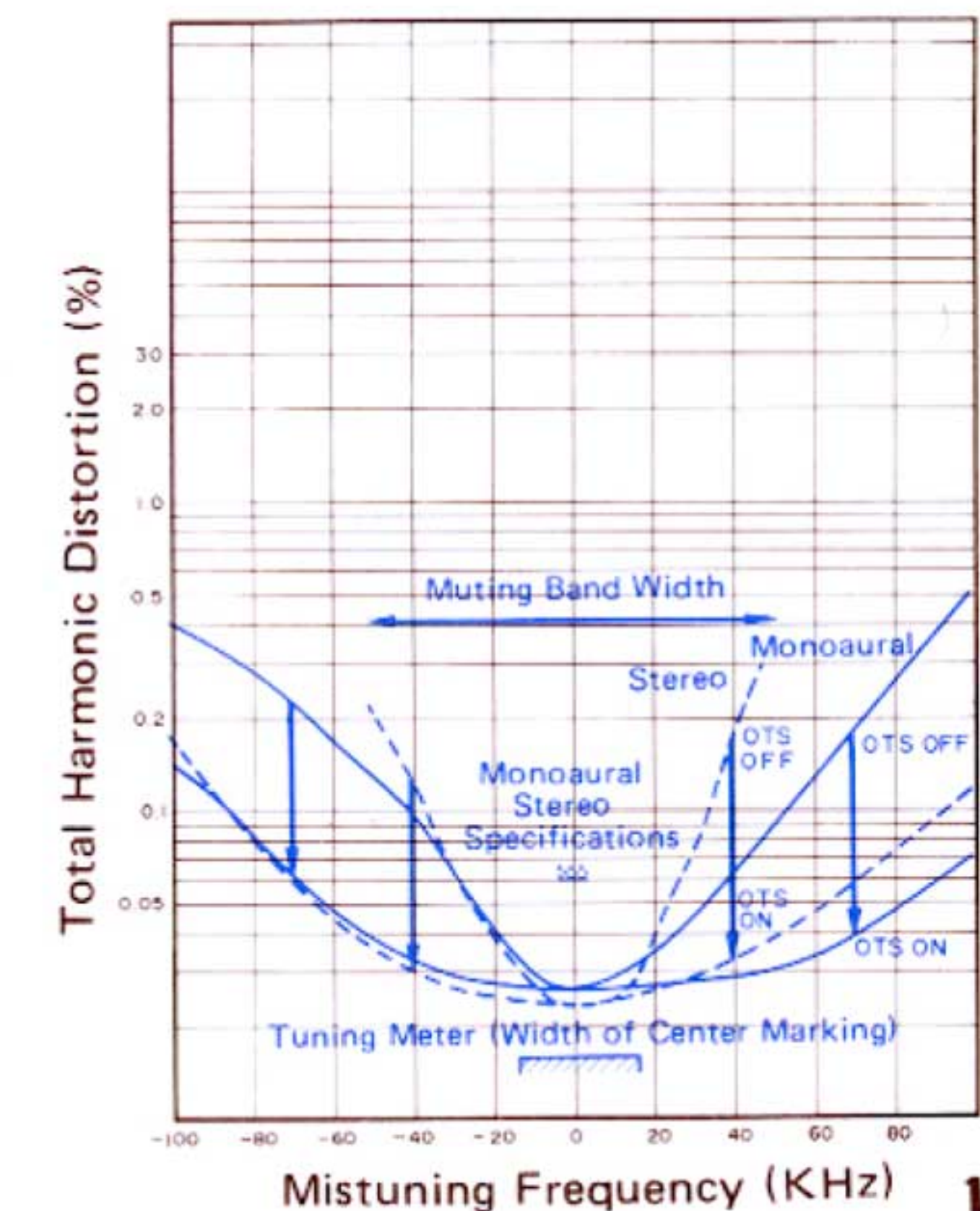

Frequency In Terms Of Total Harmonic Distortion Characteristics

- The monoaural distortion rate is mainly a matter of the IF stage band width or the linearity of discriminator. Stereo distortion increases with MPX circuit distortion or pilot signal leakage in addition to the effect from the wider IF stage band.
- The drop at 10kHz seen with the monoaural curve is ascribed to the fading of the second harmonic wave from the tuner low-pass filter. The reason for the rise in the stereo frequency in the high range is the 19kHz leakage or appearance of beat. The T-1, however, displays a good level of less than 0.1% even at 10kHz.

Frequency Characteristic And Separation Characteristic

- The wave frequency characteristic is measured by

■ Modulation Frequency vs. Total Harmonic Distortion

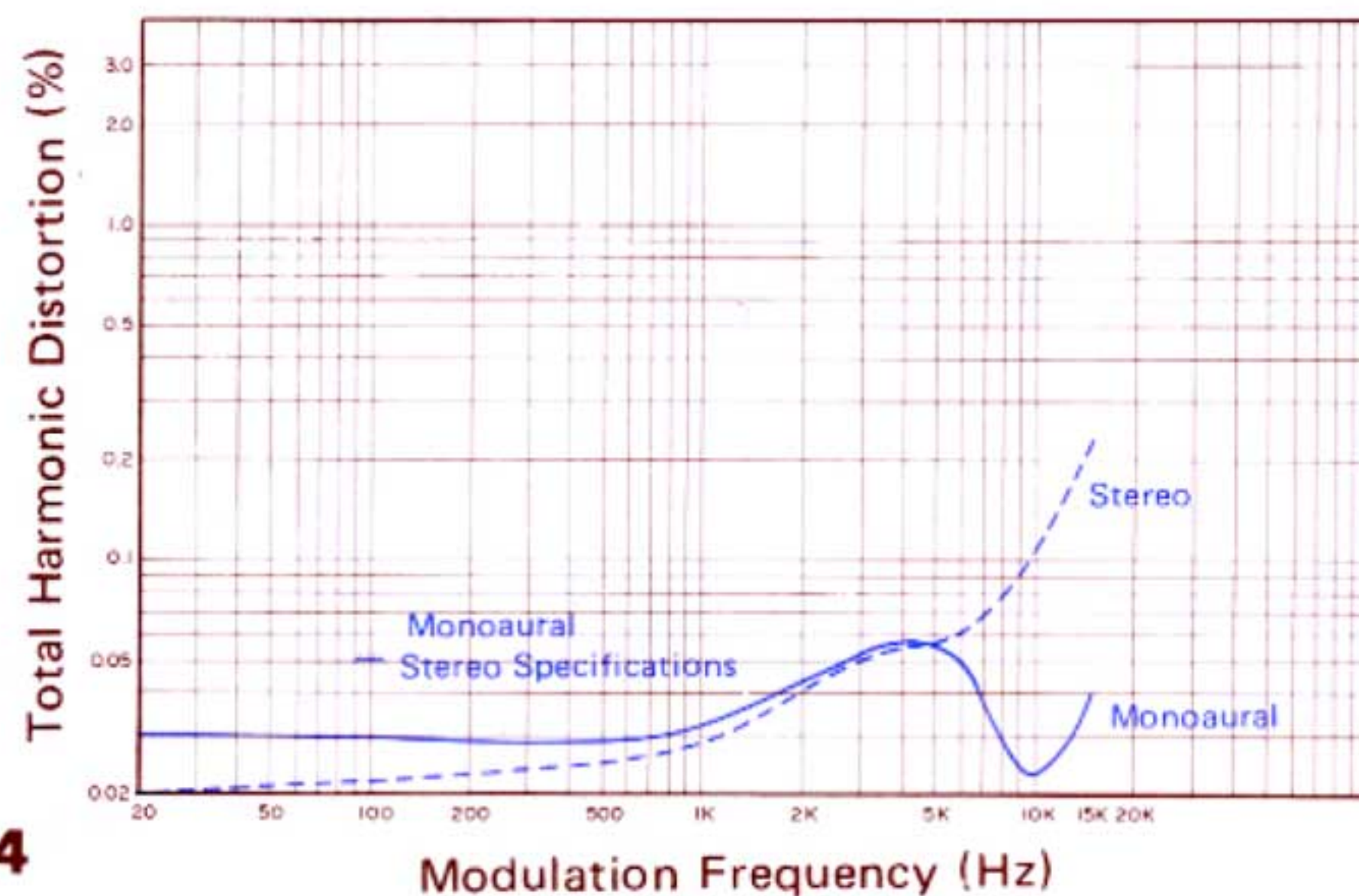

varying the modulation frequency of the stereo signal generator with the input signal level in the uniform state, and it is largely determined by the low-pass de-emphasis curve deviation. The measurement data serve as the basis for further calculation in which compensation is made for the de-emphasis curve. (refer to de-emphasis curve and low pass filter characteristic).

- Since the frequency characteristic extends up to the high range, there is much noise when the program source or the station's own SN ratio is inferior. The characteristic remains virtually flat up to 18kHz across a wide range – so much so that one might think the SN ratio of the tuner itself is bad.
- In measuring the separation level, a low-pass filter is inserted to remove any effect of pilot signal leakage. (Refer to de-emphasis curve, low-pass filter characteristics.)

The stereo separation level is determined by the amplitude characteristic in the IF stage band, the phase characteristic and the MPX circuit charac-

■ Frequency Characteristic and Separation Characteristic

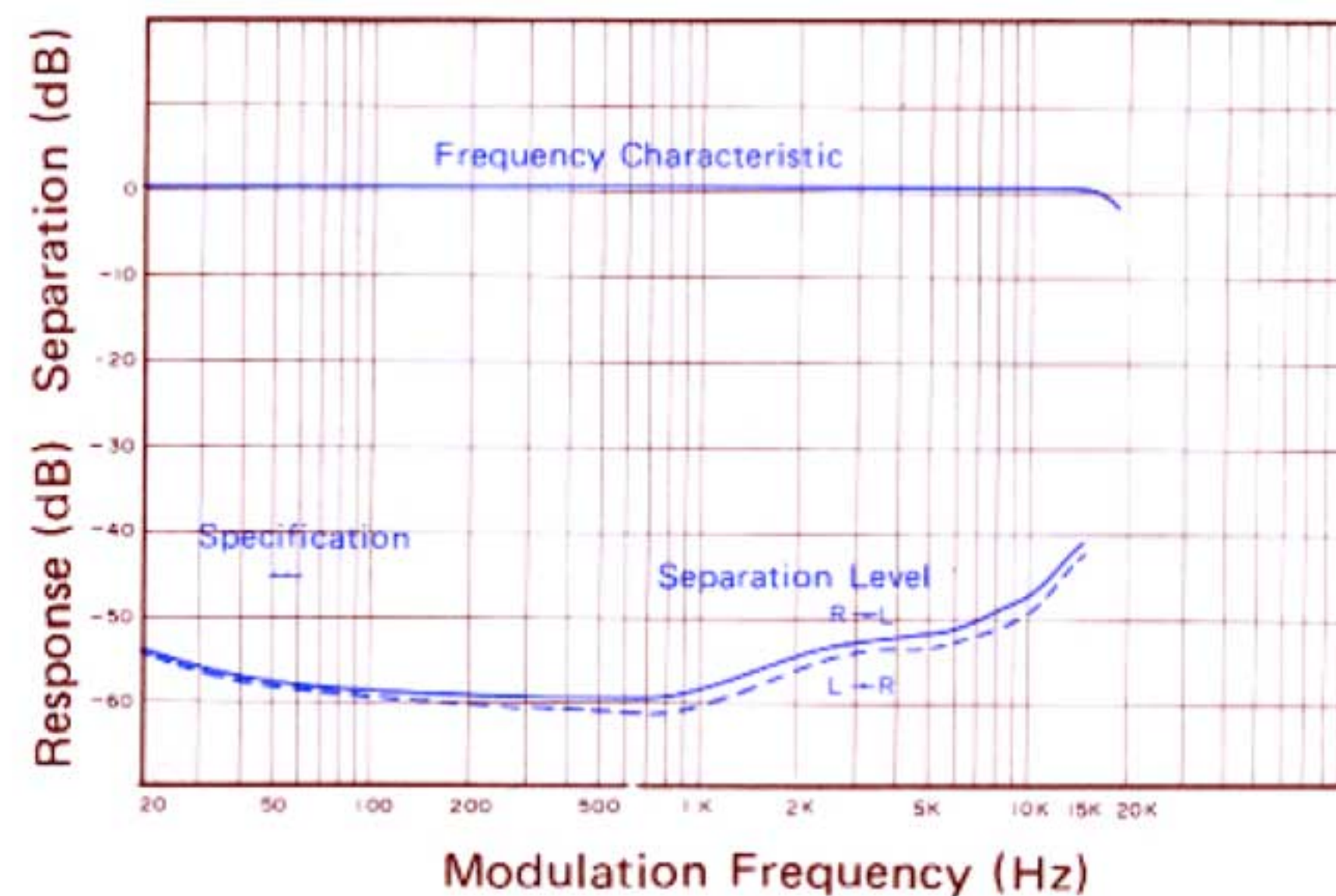

teristics. The IF stage band width in the high range in particular is apt to cause deterioration.

T-1 exhibits a sufficient value, remaining within a range from -40 to -60dB (55dB at 1kHz).

Capture Ratio

- The capture ratio is measured by means of the desired signal and the interference signal. The ratio indicates the suppression characteristic when there are two or more stations broadcasting on the same frequency and the weaker FM frequency is suppressed by a stronger one. When many stations are involved, the capture ratio permits you to know whether or not there is jamming.
- The capture ratio is affected by the characteristics of the IF stage and limiter stage, but only slightly; the jamming disappears.

■ Capture Ratio

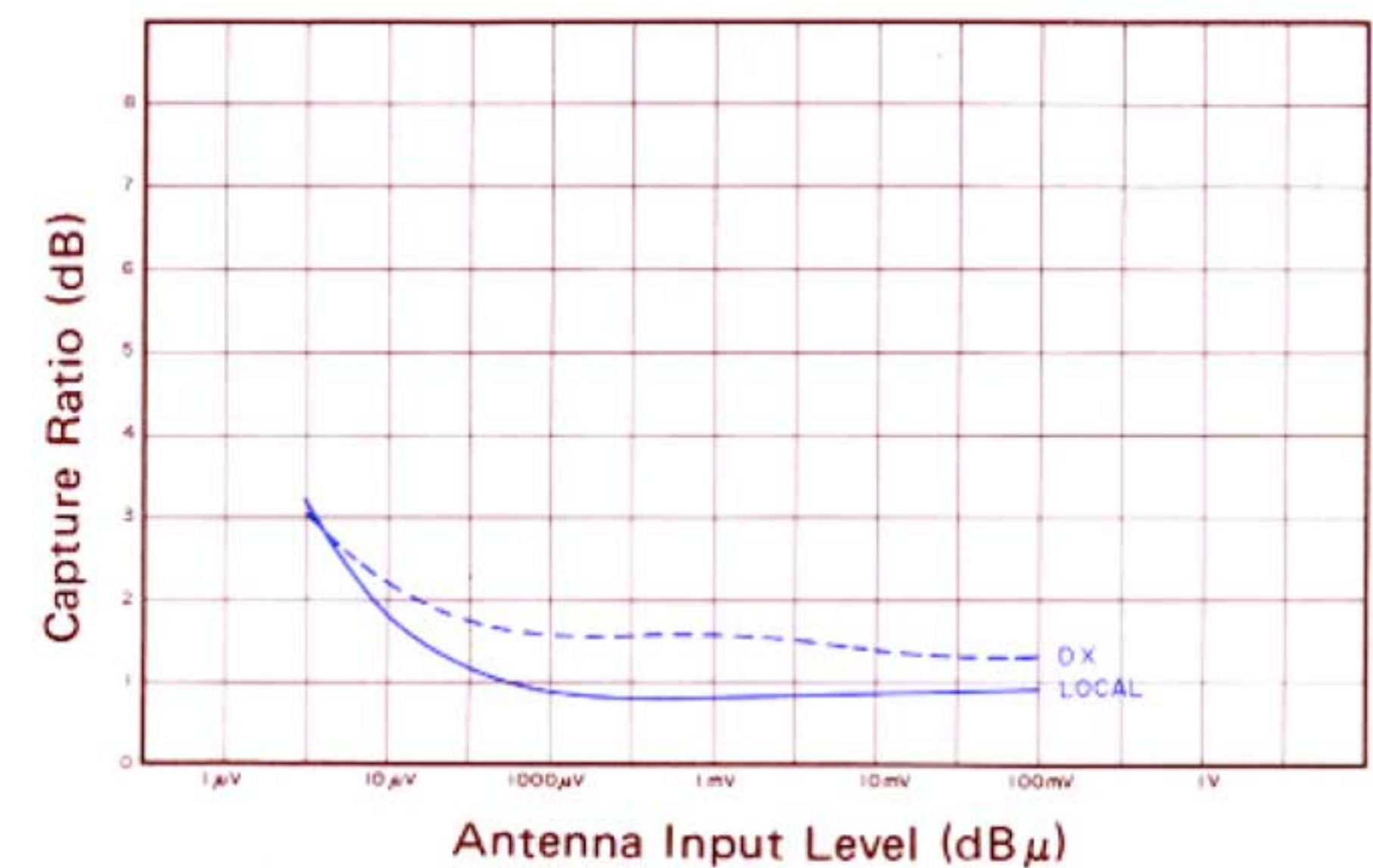

Effective Selectivity Characteristic

- Greater selectivity is needed to as FM broadcasting increase to prevent interference from nearby stations.
- Two oscillators are used to measure the desired signal and the interference signal. The curve that is obtained is used to study the blocking characteristic and the capture effect in addition to the selectivity characteristic.

MPX Circuit Characteristic Comparison

- The DC-NFB-SWITCHING PLL, MPX circuit with its high through rate DC amplifier and pilot signal cancellation feature prevents sound discoloration from mixed modulation and insures a wide T-1 frequency characteristic.
- Yamaha has greatly improved and updated conventional NFB-PLL, MPX circuitry. The present stereo distortion rate on the T-1 DC-NFB, PLL-MPX circuit is 0.004% against the former 0.045%.

De-emphasis Curve and Low-pass Filter Characteristic

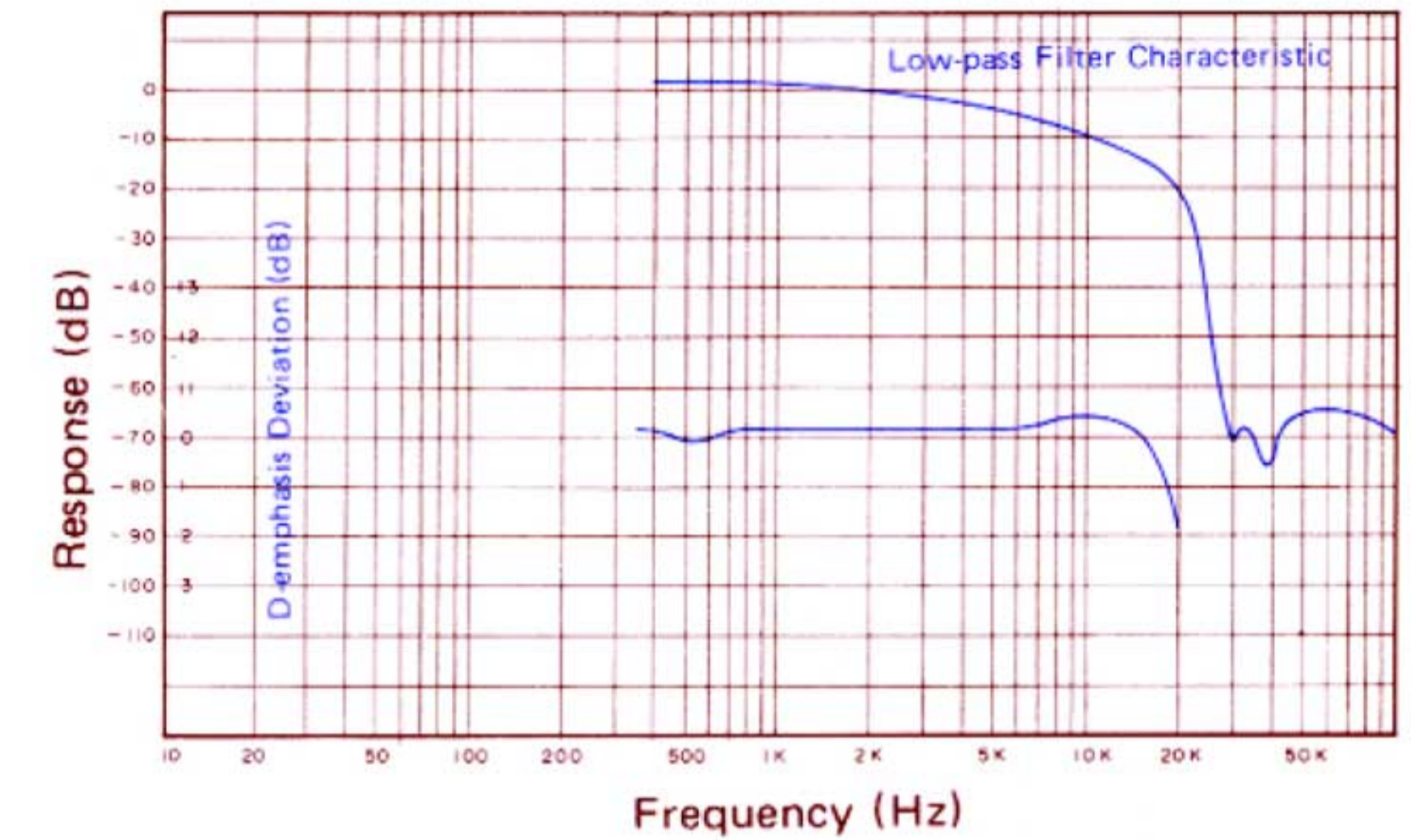

Effective Selectivity Characteristic

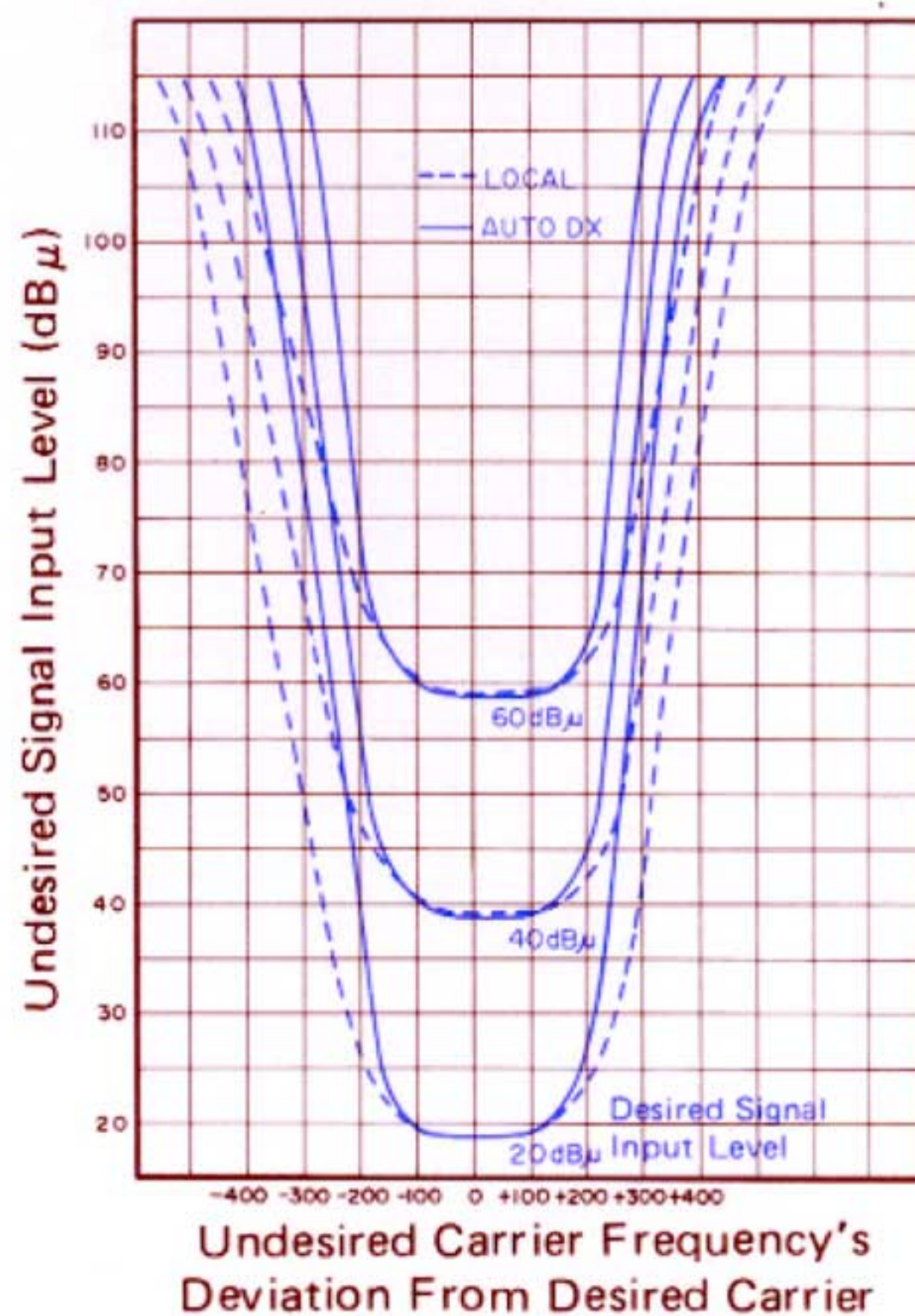

Comparison of MPX Circuit Characteristics

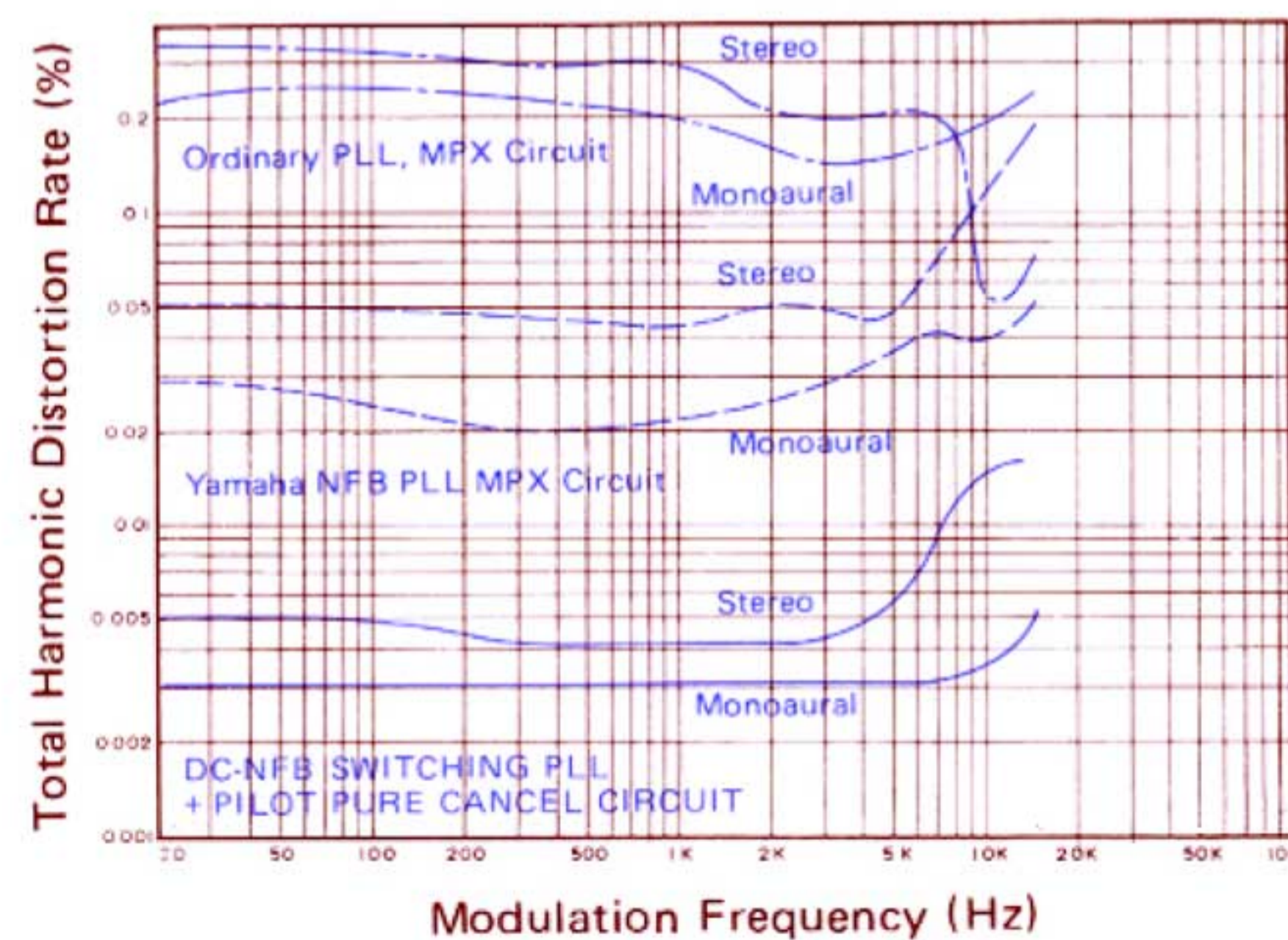

Signal Quality Meter Indication Characteristic

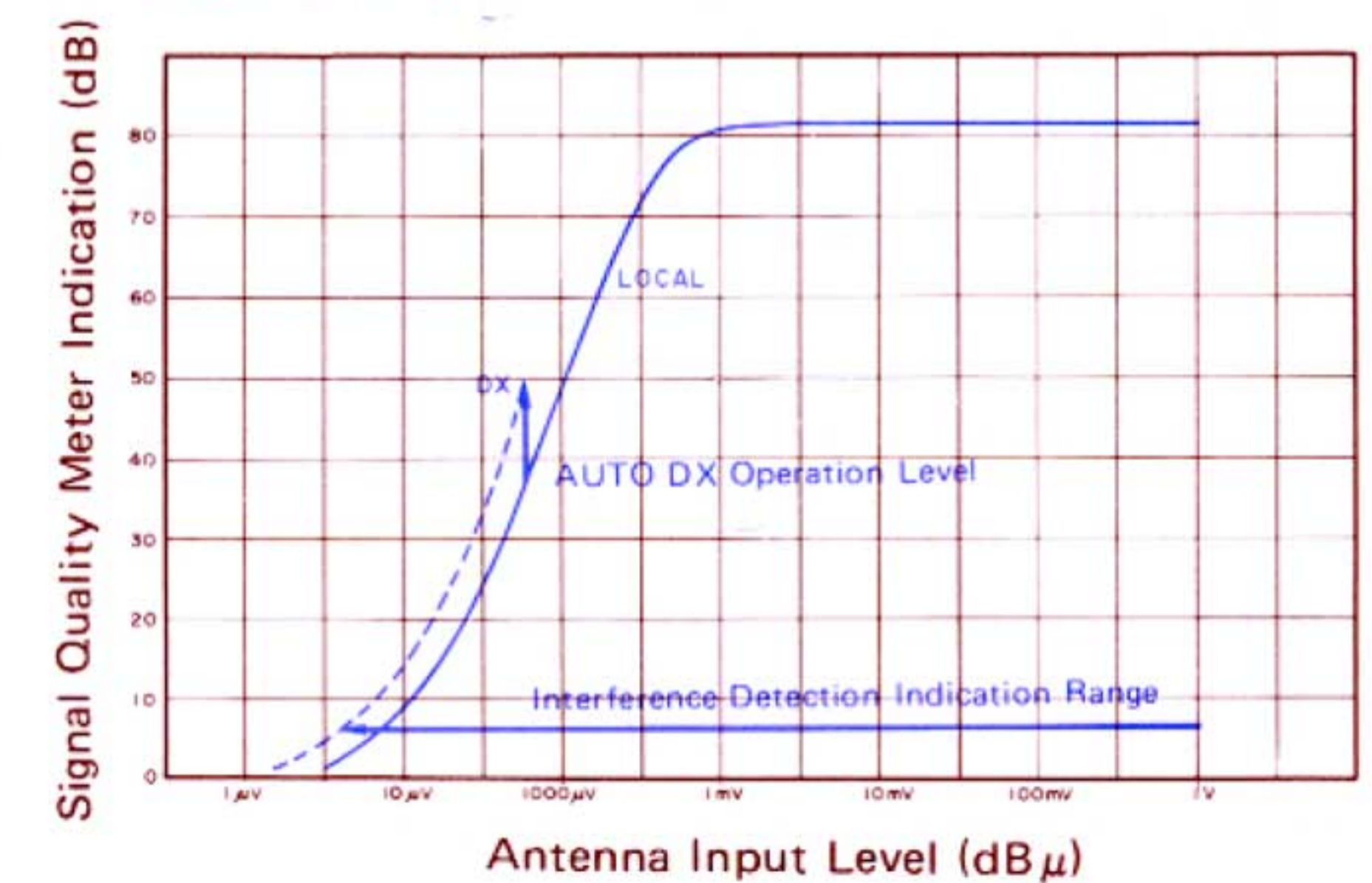

BLOCK DIAGRAM

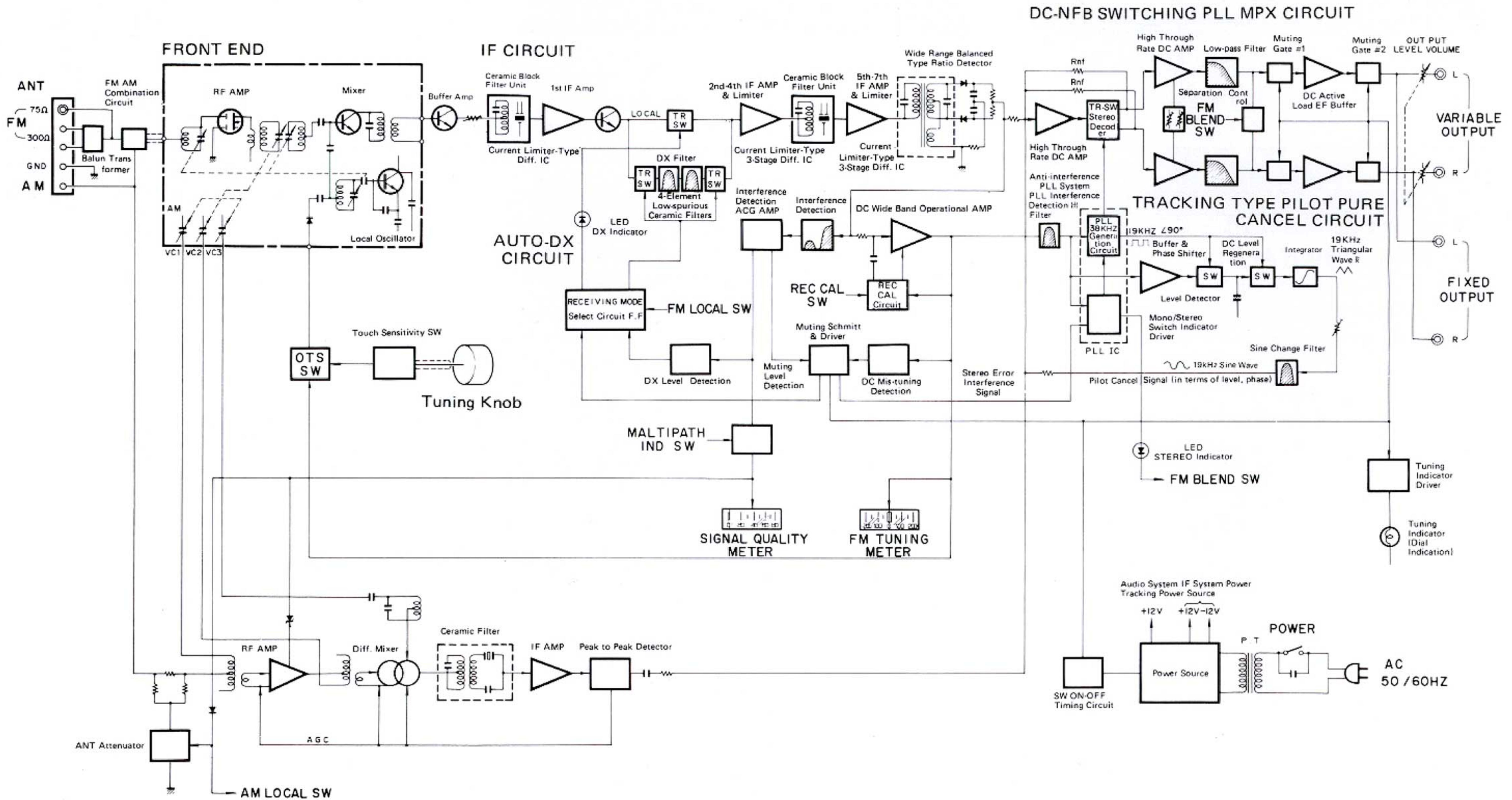

T11 SCHEMATIC DIAGRAM

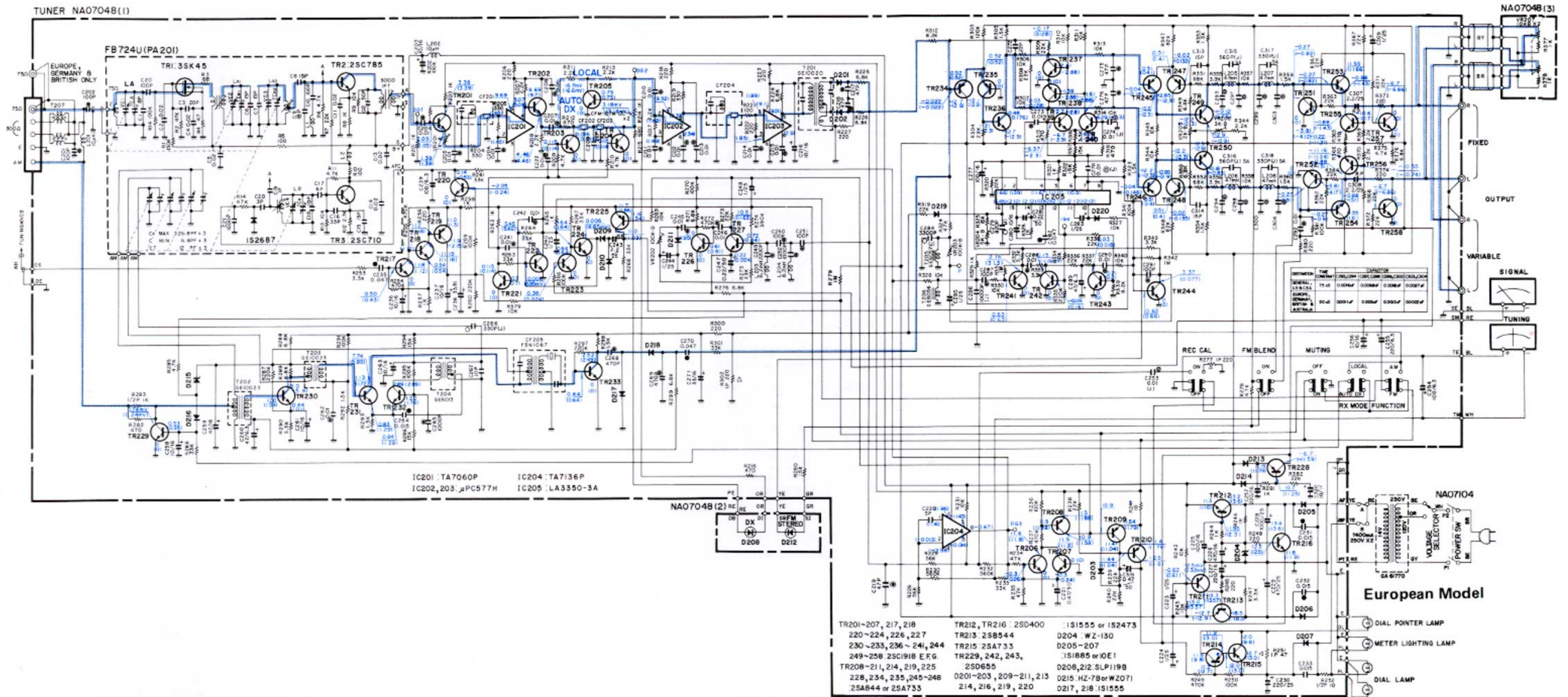

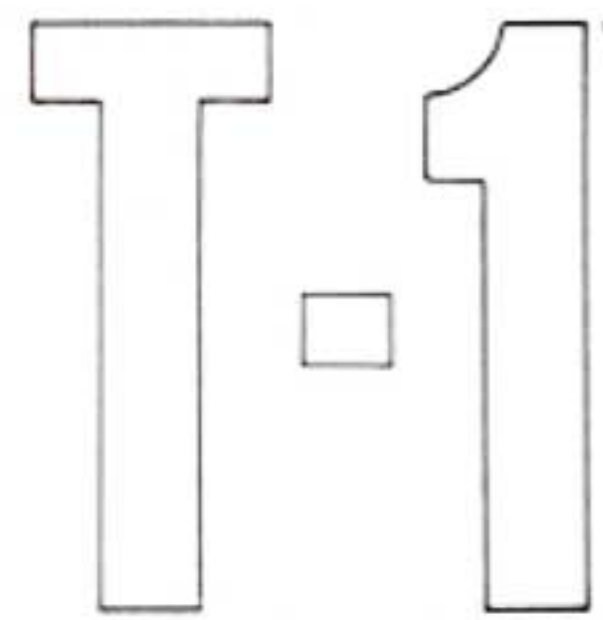

SPECIFICATIONS

FM SECTION	
Tuning Range	87.6 to 108MHz
50dB Quieting Sensitivity	
Mono	3 μ V (14.8dBf)
Stereo	35 μ V (36dBf)
Usable Sensitivity	
IHF Mono (98MHz)	1.7 μ V (300 Ω) 9.8dBf
(40kHz DEV.)	0.85 μ V (75 Ω) 9.8dBf
DIN Mono (40kHz DEV.: S/N 26dB)	1.1 μ V
Stereo (40kHz DEV.: S/N 46dB)	35 μ V
Image Response Ratio (98MHz)	90dB
IF Response Ratio (98MHz)	100dB
Spurious Response Ratio (98MHz)	100dB
AM Suppression Ratio (IHF)	65dB
Capture Ratio (IHF)	1.0dB
Alternate Channel Selectivity	
DX	92dB
Local	55dB
DIN (\pm 300kHz 40kHz DEV.)	65dB
Signal-to-Noise Ratio (at 65dBf)	
Mono	86dB
Stereo	84dB
DIN (40kHz DEV.) Mono	80dB
Stereo	78dB
Distortion (at 65dBf)	
Local Mode Mono	
100Hz	0.05%
1kHz	0.05%
6kHz	0.08%
10kHz	0.05%
Stereo	
100Hz	0.05%
1kHz	0.05%
6kHz	0.08%
10kHz	0.13%
Intermodulation Distortion (IHF)	
Mono	0.05%
Stereo	0.08%
Stereo Separation	
Local Mode	55dB (1kHz)
	46dB (50Hz~10kHz)
Frequency Response	
50Hz to 10kHz	\pm 0.3dB
30Hz to 15kHz	\pm 0.5dB

10Hz to 18kHz	+0.5dB, -3.0dB
Subcarrier Product Ratio	70dB
Muting Threshold	
AUTO DX Mode	5 μ V (19.2dBf)
AUTO DX Active Level	50 μ V (39.2dBf)
	Automatic switching to DX MODE at approx. -50dB interference level in stereo mode.

AM SECTION	
Tuning Range	525 to 1,605kHz
Usable Sensitivity (IHF)	15 μ V
Alternate Channel Selectivity	
1,000Hz \pm 10kHz	30dB
Signal-to-Noise Ratio	50dB (80dBm)
Image Response Ratio	70dB (1,000kHz)
Spurious Response Ratio	70dB (1,000kHz)
Distortion	0.4%
IF Response Ratio	70dB

AUDIO SECTION	
Output Level/Impedance	
FM (100% mod.)	0.1 to 1V/220 Ω (VR min. to max.) 500mV/2.5k Ω (VR center)
AM (30% mod.)	25 to 250mV/220 Ω (VR min. to max.) 125mV/2.5k Ω (VR center)
REC CAL Signal	50 to 500mV/220 Ω (VR min. to max.) 250mV/2.5k Ω (VR center)
	(333Hz: Corresponding to 50% FM modulation)

GENERAL	
Semiconductors	60 Transistors, 5 ICs, 1 FET, 17 Diodes, 2 Zener Diodes, 2 LEDs, 2 FM Ceramic Filters, and 1 AM Ceramic Filter
Power Supply	
General model	110~130V/ 220~240V, 50/60Hz
European model	110~130V/ 220~240V, 50Hz
North European model	220V, 50Hz
British & Australian models	240V, 50Hz
Power Consumption	12W 13W (British & Australian models)
Dimensions (W x H x D)	435 x 97 x 376mm (17-1/8" x 3-13/16" x 14-13/16")
Weight	5.7kg (12 lb 9 oz)

1. Measuring Instruments

This tuner was adjusted and measured by the following measuring instruments which include standard type and our specially-specified ones.

VHF FM SG: MSG-297 or 296 (Meguro Denpa Sokki)

VHF FM SG: GE-501A (Ando)

Stereo Modulator: MSG-211FSII

(Meguro Denpa Sokki)

Matching Transformer (50 to 300 Ω): ST Model 100

(Sound Technology)

Distortion Analyzer: YHP-4333A

(Yokogawa-Hewlett-Packard)

2. Adjustment and Measurement Conditions

Adjustment and measurement were made in accordance with the surrounding and measurement conditions provided by our company. (Conform to IHFM T-200.)

Specification subject to change without notice.

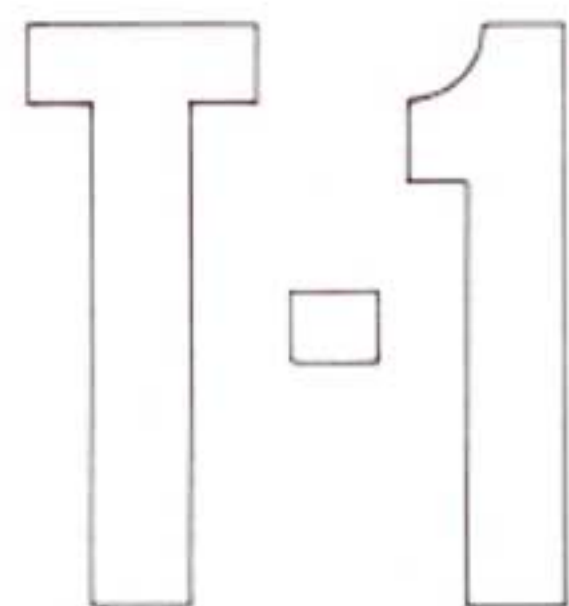

TROUBLESHOOTING

Before assuming that your T-1 is malfunctioning, check the following troubleshooting list. There may be corrective action you can undertake by yourself without having to call a service representative.

	Fault	Cause	Cure
AM Broadcast Reception	Weak reception	No FM antenna	Install an FM antenna both for FM and AM.
	A persistent "hum" occurs when the station is tuned in.	Known as modulation hum, this can affect whole areas where reception conditions are unfavorable.	This cannot be eliminated in certain areas, but changing the T-1 location may help.
	Intermittent crackling or continuous background roar.	Atmospheric electricity, electric storms, fluorescent lighting or other electrical equipment.	Install outdoor FM antenna away from static source and ground carefully to reduce fault.
	High pitched whistles or screeching, particularly at night.	Signals from nearby stations are interfering with reception.	A certain amount of interference from adjacent stations cannot be helped.
The T-1 is being operated next to a TV set.		Keep the TV and tuner apart.	
FM Broadcast Reception	Occasional crackling interference, especially in poor reception areas.	Ignition noise from passing cars, motorcycles.	Install a tall FM antenna as far from the road as possible. Use a coaxial feeder.
		Interference from thermostat-equipped electricals.	Equip the offending device with a noise suppressor.
	Stereo reception ruined by annoying static.	FM stereo broadcasts are prone to this in remote areas with weak antenna input.	Install an outdoor FM antenna, or increase the number of elements in the one you already have. Switch on FM BLEND or change from FM MUT./OTS to OFF/MULTIPATH.
	The FM STEREO indicator flickers and there is much static during stereo reception.	Insufficient antenna input, imperfect tuning.	Install an antenna to match your local signal strength.
	Sound is distorted or reception not clear despite use of an outdoor FM antenna.	Signal input from the antenna is too strong.	Try changing back to the indoor T-type antenna (standard equipped).
	During stereo test transmissions, sound which should come from only one channel is heard faintly from the other.	This is the crosstalk phenomenon. A certain degree is normal.	This does not constitute a fault as long as the leakage of one channel into the other is very small compared to the normal level for that channel.

Service should be requested at the point of purchase or at the audio department of your nearest Yamaha dealer.

SINCE 1887  **YAMAHA**
NIPPON GAKKI CO., LTD. HAMAMATSU , JAPAN