

STEREO POWER AMPLIFIER

B-2x

SERVICE MANUAL

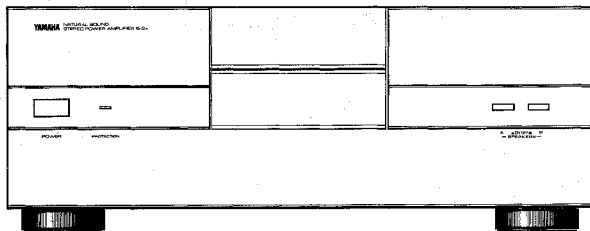

● FRONT PANEL

■ CONTENTS

SPECIFICATIONS.....	1	SCHEMATIC DIAGRAM.....	4
BLOCK DIAGRAM.....	1	CIRCUIT BOARD.....	5
NAMES OF THE PARTS.....	2	EXPLODED VIEW.....	7
DISASSEMBLY PROCEDURE.....	2	PARTS LIST.....	9
ADJUSTMENT.....	3	PARTS LIST.....	11

004609

SINCE 1887



YAMAHA

NIPPON GAKKI CO., LTD. HAMAMATSU, JAPAN

2.0K-151 (1) Printed in Japan '85.1.

TO SERVICE PERSONNEL

1. Critical Components Information.

Components having special characteristics are marked Δ and must be replaced with parts having specifications equal to those originally installed.

2. Leakage Current Measurement (For 120V Model Only).

When service has been completed, it is imperative that you verify that all exposed conductive surfaces are properly insulated from supply circuits.

● Meter impedance should be equivalent to 1500 ohm shunted by 0.15 μ F.

● Leakage current must not exceed 0.5mA.

● Be sure to test for leakage with AC plug in both polarities.

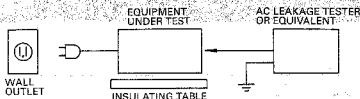

IMPORTANT NOTICE

This manual has been provided for the use of authorized Yamaha Retailers and their service personnel. It has been assumed that basic service procedures inherent to the industry, and more specifically Yamaha Products, are already known and understood by the users, and have therefore not been restated.

WARNING: Failure to follow appropriate service and safety procedures when servicing this product may result in personal injury, destruction of expensive components and failure of the product to perform as specified. For these reasons, we advise all Yamaha product owners that all service required should be performed by an authorized Yamaha Retailer or the appointed service representative.

IMPORTANT: The presentation or sale of this manual to any individual or firm does not constitute authorization, certification, recognition of any applicable technical capabilities, or establish a principal-agent relationship of any form.

The data provided is believed to be accurate and applicable to the unit/s indicated on the cover. The research, engineering, and service departments of Yamaha are continually striving to improve Yamaha products. Modifications are, therefore, inevitable and changes in specification are subject to change without notice or obligation to retrofit. Should any discrepancy appear to exist, please contact the distributor's Service Division.

WARNING: Static discharges can destroy expensive components. Discharge any static electricity your body may have accumulated by grounding yourself to the ground buss in the unit (heavy gauge black wires connect to this buss).

IMPORTANT: Turn the unit OFF during disassembly and parts replacement. Recheck all work before you apply power to the unit.

SPECIFICATIONS

CONTINUOUS POWER	
8 Ω (20Hz~20KHz, T.H.D. 0.002%)	170W+170W
6 Ω (20Hz~20KHz, T.H.D. 0.002%)	200W+200W
4 Ω (20Hz~20KHz, T.H.D. 0.003%)	240W+240W
DIN STANDARD OUT PUT POWER PER CHANNEL	
1KHz 1%/10% THD 4 Ω	306W/350W (G)
DYNAMIC HEADROOM	
8 Ω / 6 Ω / 4 Ω	1.86dB/2.27dB/2.70dB (U)
DYNAMIC POWER PER CHANNEL	
1KHz 8 Ω / 6 Ω / 4 Ω / 2 Ω	262W/337W/447W/625W (U)
POWER BANDWIDTH	
8 Ω (T.H.D. 0.02%, 85W)	10Hz~100KHz
INPUT SENSITIVITY/IMPEDANCE	
(8 Ω, 170W, 1KHz)	1.3V/25KΩ
QUENCY RESPONSE	
(8 Ω, 1W) 10Hz	0dB
1KHz	0dB
100KHz	-1dB
TOTAL HARMONIC DISTORTION	
10Hz~20KHz (8 Ω, 85W)	LESS THAN 0.002%
IM DISTORTION RATIO	
(8 Ω, 85W, 50Hz, 7KHz)	LESS THAN 0.002%

CHANNEL SEPARATION	
(INPUT SHORTED, VR:MAX, OUTPUT CH 120W/8 Ω)	
1KHz	MORE THAN 95dB
20KHz	MORE THAN 75dB
RESIDUAL NOISE	
(INPUT SHOSTED, IHF A NET-WORK, RL=8 Ω)	23μV
S/N RATIO	
(INPUT SHORTED, IHF A NET-WORK, RL=8 Ω)	LESS THAN 124dB
DAMPING FACTOR (8 Ω, 1KHz)	
	200
POWER SUPPLY	
	AC100V 50/60Hz (J)
	110-120/220-240V 50/60 (R)
	AC120V 60Hz (U)
	AC220V 50Hz (G)
POWER CONSUMPTION	
	470W
	540W (U)
	1300W (G)
AC DIMENSIONS	
	300W (MAX)
WEIGHT	
	435×164×422mm
	25kg

* Specifications subject to change without notice.

J Japanese Model
 R General Model
 U U·S·A Model
 G European Model

BLOCK DIAGRAM

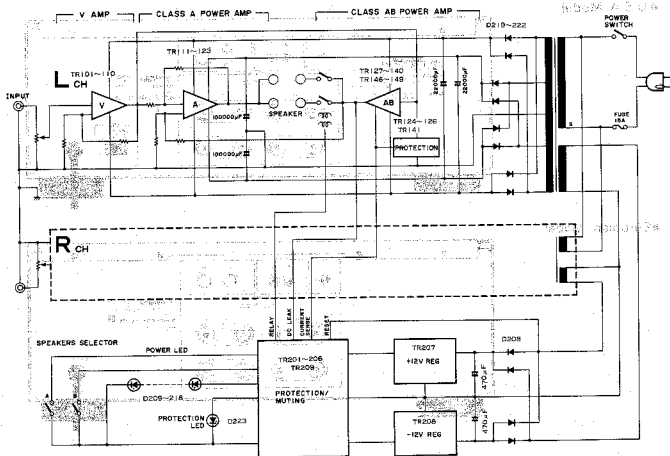

REAR PANELS

Japanese Model

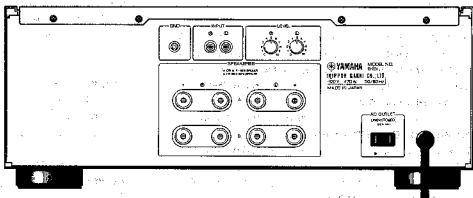

General Model

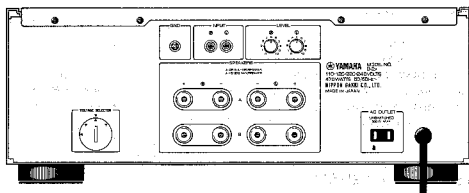

U.S.A. Model

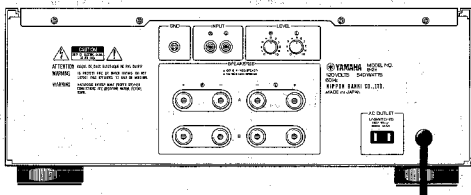

European Model

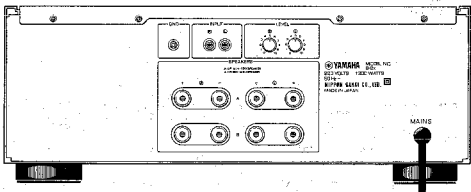

NAME OF THE PARTS

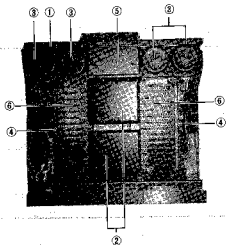

- ① AG Outlet
- ② Power Transformer
- ③ Electrolytic Cap.
- ④ Main Circuit Board
- ⑤ Relay Circuit Board
- ⑥ Heat Sink

DISASSEMBLY PROCEDURES

Remove parts in order to Disassembly as numbered.

1. Remove the top cover by removing screw ①.
2. Remove the side panel by removing screw ②.
3. Remove the Front panel and the bottom cover by removing screw ③ and ④.
4. Remove the Heat Sink by removing screw ⑤.
5. Remove the Main Circuit Board by removing screw ⑥.

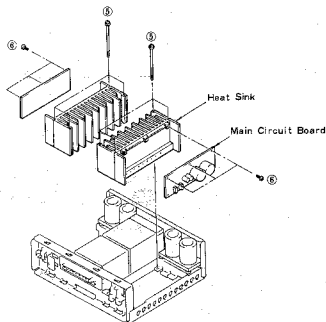
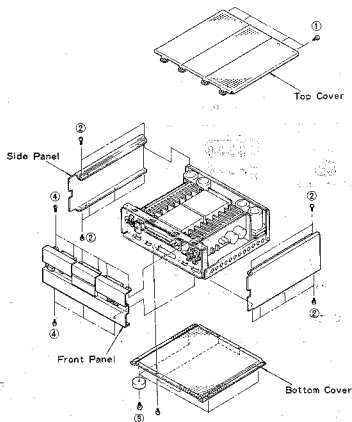

ADJUSTMENTS

Before Adjustment

- Wait 3~4 minutes after power on to stabilize amplifier operation.
- Make sure that the MAIN VOLUME is minimum.

Step	Adjustment	Location	Test Equipment	Test point	Standard
1	DC BALANCE	VR101	DC-V Meter	Test point A—B	$0 \pm 10\text{mV}$
2	IDLING A CLASS AMP	VR102	DC-V Meter	Test point APE—A	$200\text{mV} \pm 10\text{mV}$
3	IDLING AB CLASS AMP	VR103	DC-V Meter	Test point BNE—B	$15\text{mV} \pm 3\text{mV}$

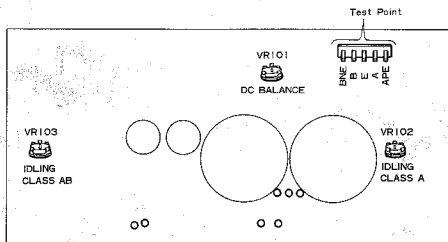

■総合回路図(SCHEMATIC DIAGRAM)

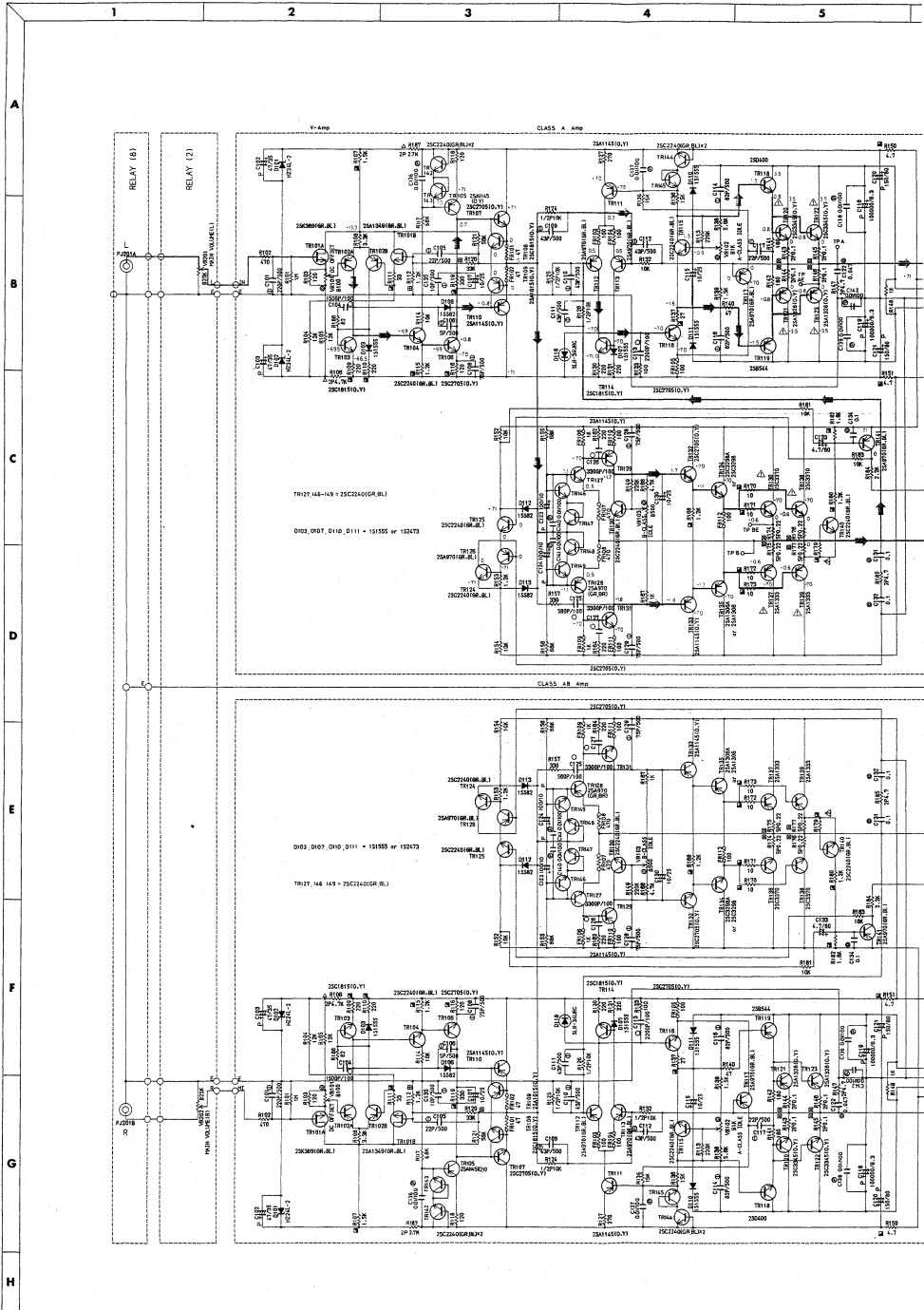

6 7 8 9 10

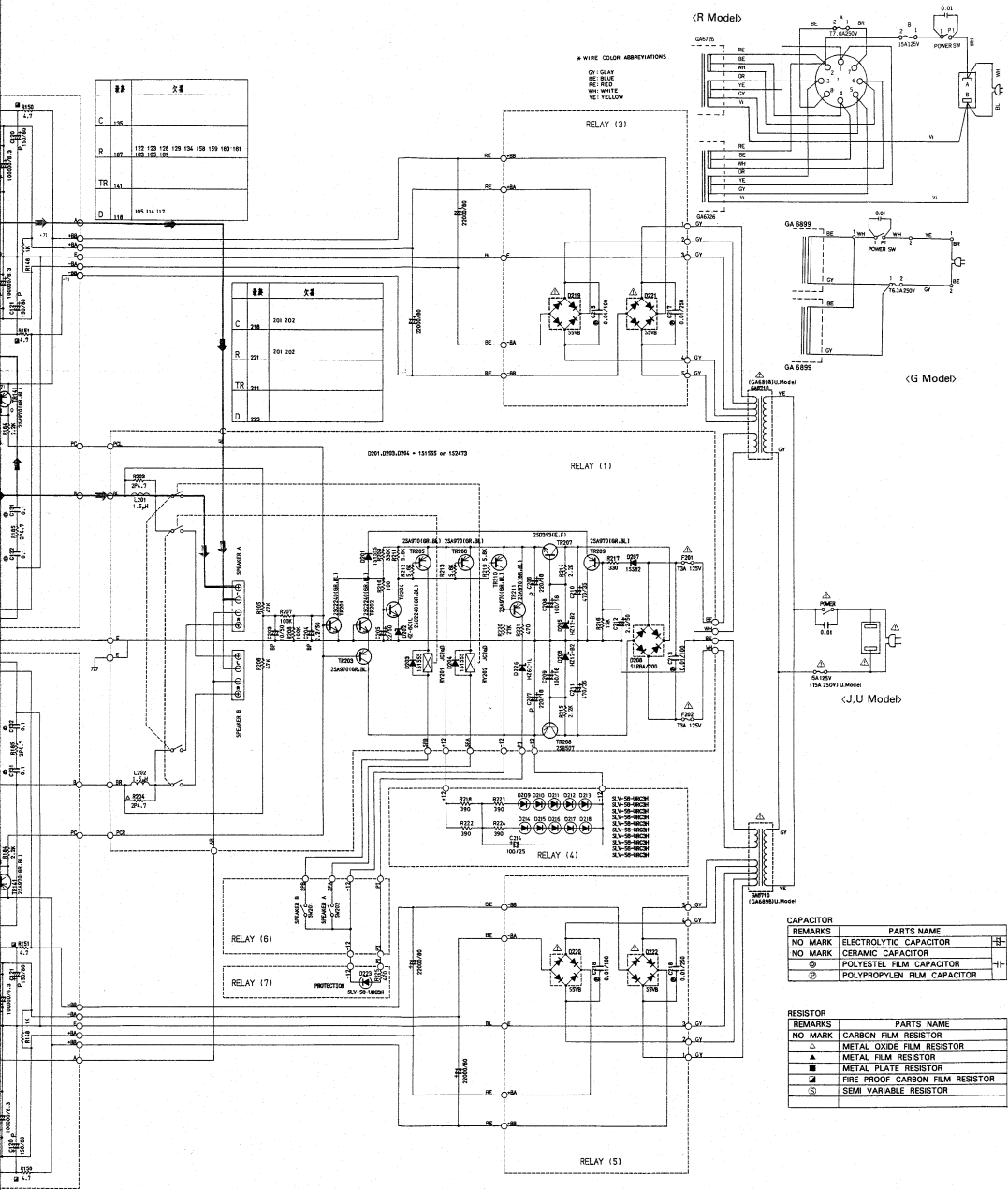

<R Model>

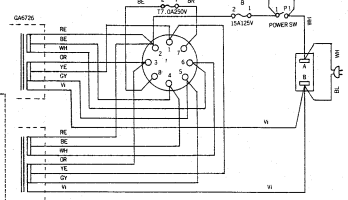

<G Model>

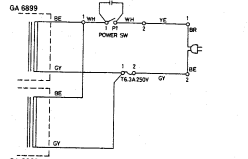

<J.U Model>

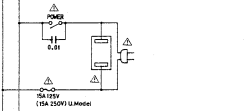

品番	数量
C 336	
R 187	132 133 135 139 134 150 159 160 163
TR 141	
D 118	105 114 117

品番	数量
C 218	201 202
R 221	201 202
TR 211	
D 222	

REMARKS	PARTS NAME
NO MARK	ELECTROLYTIC CAPACITOR
△	CERAMIC CAPACITOR
□	POLYESTER FILM CAPACITOR
⊕	POLYPROPYLENE FILM CAPACITOR

REMARKS	PARTS NAME
NO MARK	CARBON FILM RESISTOR
△	METAL OXIDE FILM RESISTOR
▲	METAL FILM RESISTOR
■	METAL PLATE RESISTOR
⊕	FIRE PROOF CARBON FILM RESISTOR
⊖	SEMI VARIABLE RESISTOR

*電圧は内部抵抗10MΩの電圧計で測定したものです。
*本回路図は標準回路図です。改良のため予告なく変更することがございます。

* All voltages are measured with a 10 MΩ/DC electric volt meter.
* Schematic diagram is subject to change without notice.

PRINTED CIRCUIT BOARD PATTERN SIDE~MAIN

PRINTED CIRCUIT BOARD PATTERN SIDE~RELAY

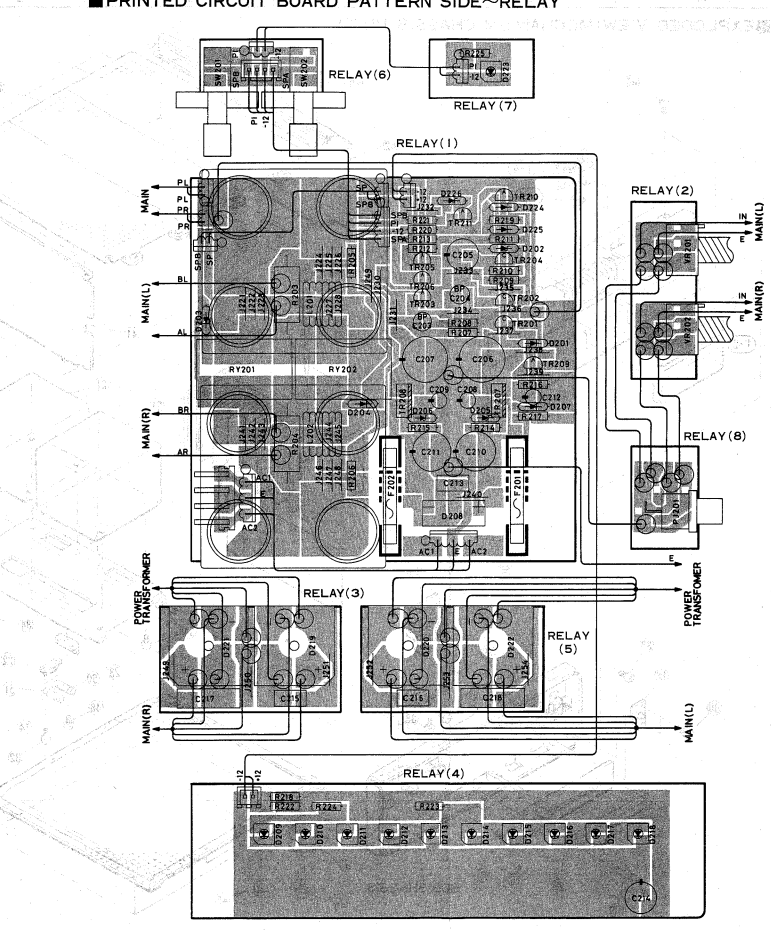
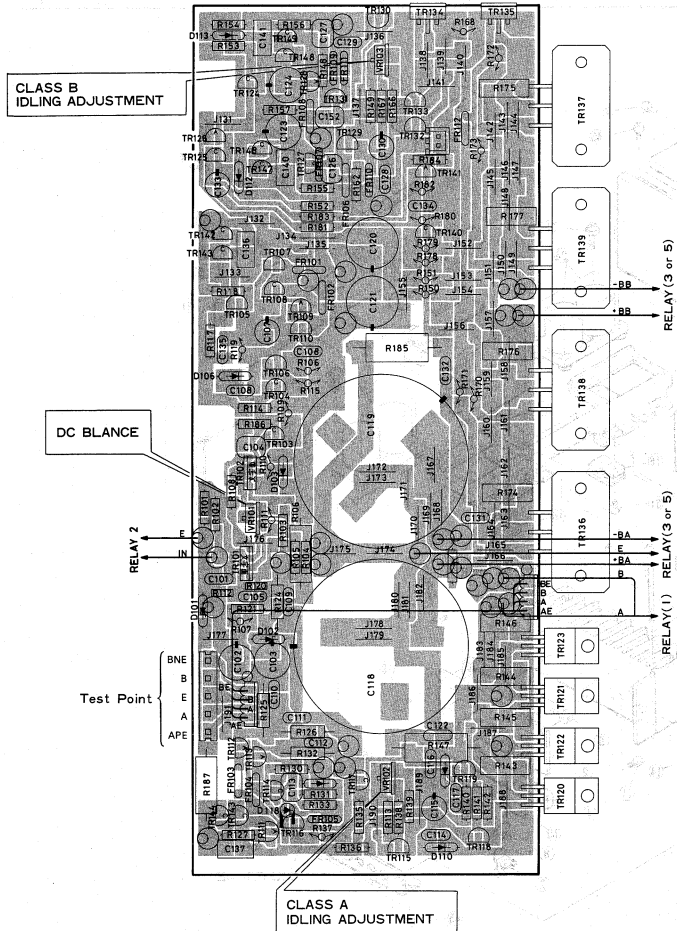

B-2x**B-2x**

A | B | C | D | E | F | G | H | I

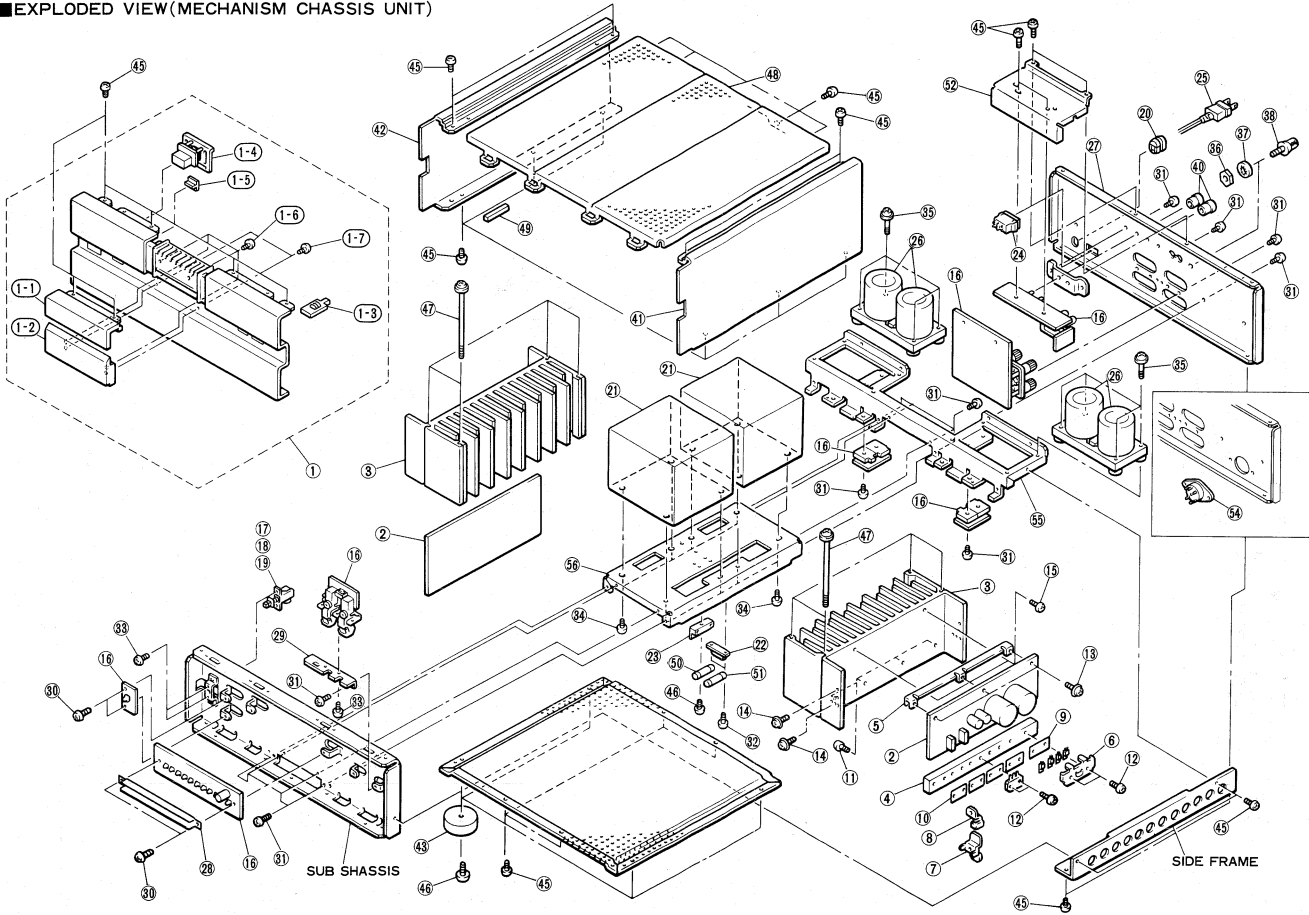
EXPLODED VIEW (MECHANISM CHASSIS UNIT)

PARTS LIST~MECHANISM CHASSIS UNIT

Ref. No.	Part No.	Description	部 品 名	Remarks	Common Model	Markets	ランク
1	NB:61:79:20	Panel Unit	パネルユニット				
1-1	BA:08:91:00	Sub Panel A	サブパネルA				
1-2	BA:08:91:10	Sub Panel B	サブパネルB				
1-3	NB:60:14:80	Push Button Assy	プッシュボタンASSY		B-70		
1-4	NB:61:82:30	" Assy	"				
1-5	CB:09:95:50	Lamp Lens	ランプレンズ		B-6		
1-6	ED:33:00:66	Binding Head Screw	3x6 FCM3-BI	PACK			
1-7	ED:33:00:86	Binding Head Screw	3x8 FCM3-BI	PACK			
2	NA:08:33:10	Main Circuit Board	メインシート				
3	BA:08:90:80	Heat Sink	放 熱 板				
4	BA:08:90:90	Block Tr	トリブロック				
5	AA:82:00:50	Circuit Board Holder	シートホルダー		A-2000		
6	AA:82:00:80	Holder Tr	トリホルダー		A-2000		
7	AA:82:00:90	"	"		A-2000		
8	AA:82:04:40	"	"		A-2000		
9	CB:82:62:20	Mica Circuit Board	マイカシート		A-2000		
10	IL:00:05:10	Mica Base	AC-243 マイカベース				
11	ED:34:01:06	Binding Head Screw	4x10 FCM3-BI	PACK			
12	ED:33:01:06	Binding Head Screw	3x10 FCM3-BI	PACK			
13	EK:36:50:80	BW Head Tapping Screw	3x8 FCM3-BI	PACK			
14	ED:33:00:66	Binding Head Screw	3x6 FCM3-BI	PACK			
15	EI:33:00:86	Bind Tapping Screw	3x8 FCM3-BI	PACK			
16	NA:08:33:20	Relay Circuit Board	リレーシート				
17	KA:80:43:00	Push Switch	TV-8 ESB-997 プッシュスイッチ				
18	FI:38:41:00	Ceramic Cap	VA-1 0.01 セラコン			R	
19	CB:60:19:00	Cover	HY-0103 コンデンサーカバー			J	
20	CB:07:27:50	Cord Stopper	CM-22B コードストッパー			R,G	
"	CB:80:68:50	"	SR-6N3-4 "			J,U	
21	GA:67:10:00	Power Transformer	電源トランス			J,R,U	
"	GA:88:98:00	"	"			U	
"	GA:88:99:00	"	"			G	
"	GA:87:28:00	"	"			R	
22	LA:00:29:50	2P Relay Terminal	MA0092A 2 P 中継端子台			J,U,G	
23	LB:20:13:40	Fuse Holder	IPFH フェノール ヒューズホルダー			J	
"	LB:20:14:70	"	IPFHMフェノール			G	
24	LB:20:18:10	AC Outlet	S-6498 黒速 ACアウトレット				
25	MG:00:12:20	Power Cord	2m 15A 125V 電源コード			J	
"	MG:00:07:80	"	2m 6A 250V "			R	
"	MG:00:09:10	"	2m 6A 250V "			G	
"	MG:00:07:10	"	2.44m 13A 125V "			U	
26	FZ:00:53:80	Electolytic Cap	22000/80 ケミコンセット				
27	AA:82:05:60	Rear Panel	リヤパネル			J	
"	AA:82:05:70	"	"			R	
"	AA:82:61:30	"	"			U	
"	AA:82:61:40	"	"			G	
28	AA:82:06:20	L.E.D	LEDリフレクター				
29	AA:82:08:30	Switch Holder	スイッチホルダー				
30	EI:33:01:26	Bind Tapping Screw	3x12 FCM3-BI	PACK			
31	EI:33:00:86	"	3x8 FCM3-BI	PACK			
32	EI:33:01:48	"	3x14 FCM3-BI	PACK			
33	ED:33:00:66	Bind Head Screw	3x6 FCM3-BI	PACK			
34	EZ:00:13:20	Cap Screw	4x6 FCM3-BI				
35	EX:60:00:80	Cup Screw	3x24 FCM3-BI				

*New Parts (新規部品)

Ref. No.	Part No.	Description	部品名	Remarks	Common Model	Markets	ランク
36	LA 00:16:80	HEXAGONAL NUT	M8×0.75	六角ナット			
37	EV 41:00:86	Rock Washer	円筒形 8S	書付厚金	PACK		
38	NB 08:26:40	Ground Terminal Screw	#8264	アース端子 ASSY			
39	AA 62:05:50	Bottom Cover		ボトムカバー			
40	BA 06:66:10	Knob		ツマミ		M-4	
41	BA 08:90:60	Side Cover		サイドカバー	R		
42	BA 08:90:70	#		#	L		
43	BA 08:92:20	Tran Leg		レッグ ASSY		C-2X	
44	CB 06:88:80	Plastic Rivet		プラスチックリベット			
45	EI 33:00:86	Bind Tapping Screw	3×8 FCM3-BI	バインドタッピングネジ	PACK		
46	EI 34:00:66	Bind Tapping Screw	4×6 FCM3-BI	バインドタッピングネジ	PACK		
47	EX 60:00:30	BW Head Screw	4×132 FCM3-BI	ブレークシャフト小ネジ			
48	AA 62:04:90	Top Cover		トップカバー			
49	CB 62:70:40	Görn Antivibration		防振ゴム			
#	CB 06:92:50	Binding Tie		インシュロックタイ			
50	KB 00:12:70	FUSE	15A 125V	ヒューズ			
	KB 00:13:80	#	15A 250V	#		U	△
	KB 00:17:60	#	T6.3A 250V	#		G	△
51	KB 00:13:00	#	T7.0A 250V	#		R	△
52	AA 62:13:60	COVER		カバー			
53	AA 62:13:70	HOLDER,CIRCUIT BOARD		ホルダー			
54	LB 20:14:80	VOLTAGE SELECTOR		電圧切換器		R	
55	AA 62:05:40	Hölder, EL Cap		ケミコンホルダー			
56	AA 62:05:90	Hölder, Transöfmer		トランスホルダー			

*New Parts (新規部品)

Carbon resistors of this amp. are 1/4 W.
There is no description about them in this parts list.
Use the "Part No." HJ350000 or equivalent.

■ PARTS LIST~ELECTRICITY

Ref. No.	Part No.	Description	部 品 名	Remarks	Common Model	Markets	ランク
	NA-08-33-10	Main Circuit Board	メインシート				
FF	12-25-60	Stylole Capacitor	560P 100V	ドウハクスチコン	C125		
FF	12-32-20	"	2200P 100V	"	C113		
FF	12-33-30	"	3300P 100V	"	C126,127		
FF	12-31-50	"	1500P 100V	"	C104		
FU	35-05-00	FE Mica Capacitor	5P 500V	F E マイカコン	C106		
FU	35-12-20	"	22P 500V	"	C105,117,135		
FU	35-14-30	"	43P 500V	"	C109-112		
FU	35-17-50	"	75P 500V	"	C108,128,129		
FU	35-18-20	"	82P 500V	"	C114,116		
FU	35-22-20	"	220P 500V	"	C101		
FV	06-74-70	Electrolytic Cap	47 μ 35V	プラスチックケミコン	C102,103		
FV	02-81-00	"	100 μ 10V	"	C123,124		
FV	08-81-50	"	150 μ 80V	"	C120,121		
FZ	00-59-50	"	100000 μ 6.3V	"	C118,119		
FT	85-41-00	Polypropylene Film Cap	0.01 μ 100V	ポリプロコン	C142		
FZ	00-54-20	Electrolytic Cap	10 μ 25V	ブラックゲート(F)コンデンサ	C107,115,130		
FZ	00-54-30	Polypropylene Film Cap	0.01 μ 100V	ポリプロコン	C136-141		
FZ	00-49-40	Mylar Capacitor	0.1 μ 50V	ドワリードマイラー	C131,132,134		
FZ	00-55-80	"	0.047 μ 50V	"	C122		
UW	68-64-70	Electrolytic Cap	4.7 μ 80V	小型ケミコン自立型	C133		
HV	45-34-70	Flame Proof Resistor	4.7 Ω ERD-25FV	不燃化カーボン抵抗	R150,151		
HV	45-41-00	"	10 Ω ERD-25FV	"	R170-173		
HV	45-43-30	"	33 Ω ERD-25FV	"	R111		
HV	45-42-70	"	27 Ω ERD-25FV	"	R137		
HV	45-51-20	"	120 Ω ERD-25FV	"	R116		
HV	45-52-20	"	220 Ω ERD-25FV	"	R109,110		
HV	45-53-30	"	330 Ω ERD-25FV	"	R119		
HV	45-53-90	"	390 Ω ERD-25FV	"	R179		
HV	45-61-20	"	1.2K Ω ERD-25FV	"	R115,168,180		
HV	45-61-50	"	1.5K Ω ERD-25FV	"	R107		
HV	45-61-80	"	1.8K Ω ERD-25FV	"	R178,182		
HL	32-62-70	Metal Oxide Resistor	2.7K Ω 2P	酸金板抵抗	R187		
HL	32-64-70	"	4.7K Ω 2P	"	R106		
HZ	00-39-30	Carbon Resistor	4.7 Ω	カーボン抵抗	R147,185		
HZ	00-39-40	"	10K Ω	"	R124-126,132		
HZ	00-24-00	Metal Plate Resistor	0.22 Ω 5P	金属板抵抗	R174-177		
HZ	00-38-30	"	0.1 Ω 2P	"	R143-146		
HU	27-61-20	Metal Film Resistor	1.2K Ω	金属皮膜板抵抗	R112		
HU	27-73-30	"	33K Ω	"	R120		
HT	18-02-40	Metal Grose VR	B500 Ω	メタルグレースVRタテ	VR103		
HT	18-02-50	"	B1K Ω	"	VR102		
HT	18-03-70	"	B100 Ω	"	VR101		
HW	79-44-70	Fuse Resistor	47 Ω	ヒューズ抵抗	FR101,102,1		
HW	79-51-00	"	100 Ω	"	FR103-105,110-112		
HW	79-54-70	"	470 Ω	"	FR107,108		
HW	79-61-00	"	1K Ω	"	FR106,109		
IA	09-70-00	Transistor	2SA970 GR.BL	トランジスタ	TR117,126,128,141		
IA	10-15-50	"	2SA1015 μ Y	"	TR109		
IA	11-45-00	"	2SA1145 μ Y	"	TR105,110,111,129,133		

Ref. No.	Part No.	Description	部 品 名	Remarks	Common Model	Markets	ランク
IA	13 49 00	Dual Transistor	2SA1349 GR,BL	デュアルトランジスタ	TR102		
IA	09 70 10	Transistor	2SA970 BL	トランジスタ	TR112,113	Interchangeable	
IA	09 70 20	"	2SA970 GR	"	TR112,113		
IC	18 15 10	"	2SC1815 φ,Y	"	TR103,108,114		
IC	22 40 00	"	2SC2240 GR,BL	"	TR104,124,125,127, 130,132-149		
IC	22 40 00	"	2SC2240 GR,BL	"	TR116,130		
IC	27 05 00	"	2SC2705 φ,Y	"	TR106,107,116, 131,132		
IE	10 45 00	Dual EFT	2SK389 GR,BL	デュアル F E T	TR101		
IX	60 30 50	Transistor	2SA1333	トランジスタ	TR137,139		
IX	60 30 60	"	2SC3370	"	TR136,138		
IX	60 22 40	Transistor	2SA1306A	"	TR135		
IX	60 22 50	"	2SC3298A	"	TR134		
IX	60 22 60	"	2SA1328	"	TR121,123		
IX	60 22 70	"	2SC3345	"	TR120,122		
IB	05 44 00	"	2SB544	"	TR119		
ID	04 00 00	"	2SD400	"	TR118		
IF	00 00 40	Diode	1S1555	ダイオード	D103,107, 110,111	Interchangeable	
IF	00 06 70	"	1S2473	"	D103,107, 110,111		
IF	00 13 80	"	1SS82	"	D106,112,113		
IF	00 20 90	Zener Diode	HZ24L-2	ツェナーダイオード	D101,102		
IF	00 23 80	LED (RED)	SLR-34URC	L E D	D118		
LA	00 20 40	Wrapping Terminal Type 1	P=5 5P	〒型ラッピング端子板			
LB	91 80 20	XH Base Pin I Model	2P	XHベースピンI型			
CB	06 92 50	Binding Tie	BK-1	インシュロックタイ			
NA	08 33 20	Protection Circuit Board		リレーシート			
FZ	00 54 30	Polypropylene Film Cap	0.01μF 100V	ポリプロコン	C213,215,216		
FZ	00 54 40	"	0.01μF 250V	"	C217,218		
FV	03 82 20	Electrolytic Cap	220μF 16V	プラスチックケミコン	C206,207		
FV	64 81 00	"	100μF 25V	"	C214		
FV	06 72 20	"	22μF 50V	"	C205		
UW	86 62 20	"	2.2μF 50V	小型ケミコン自立型	C204		
FM	11 71 00	"	10μF 50V	B・B コン	C203		
UW	83 81 00	Electrolytic Cap	100μ 16V	小型ケミコン自立型	C208,209		
UW	85 84 70	"	470μ 35V	"	C210,211		
UJ	16 82 20	"	2.2μ 50V	"	C212		
GD	90 03 70	Coil	1.5μH	タウシンコイル	L201,202		
HZ	00 39 30	Carbon Resistor	4.7Ω RM2W	カーボン抵抗	R203,204		
HS	41 20 70	Rotary VR	B25KΩ	ロータリーVR	VR201,202		
IA	09 70 00	Transistor	2SA970 GR,BL	トランジスタ	TR203,205,206, 209-211	Interchangeable	
IB	05 07 00	"	2SB507	"	TR208		
IC	22 40 00	"	2SC2240 GR,BL	"	TR201,202,204		
ID	03 13 00	"	2SD313 E,F	"	TR207		
IF	00 00 40	Diode	1S1555	ダイオード	D201,203,204, 224,225	Interchangeable	
IF	00 06 70	"	1S2473	"	D201,203,204, 224,225		
IF	00 14 00	"	1SS82	"	D207		
IF	00 15 10	Zener Diode	HZ-6C1L	ツェナーダイオード	D202,226		
IF	00 23 50	"	HZ12-B2	"	D205,206		
IF	00 42 70	LED (RED)	SLR-55URC3H	L E D (赤)	D223		

Ref. No.	Part No.	Description	部品名	Remarks	Common Model	Markets	ランク
	IF 00:44:40	"	SLV-56JRC3H	"			
	IH 00:07:70	Diode	SIRBA	ダイオード	D209-218 D208		
	IH 00:09:20	"	S5VB	"	D219-222		
	KA 90:22:30	Push Switch	NS2-2	プッシュスW	SW201,202		
	KC 00:16:10	Relay	JC20D DC24V	リレー	RY201,202		
	KB 00:02:40	Fuse	T3A 125V	ヒューズ	F201,202		
	LB 20:27:50	Pin Jack 2P		2Pピンジャック	FJ201		
	LA 00:23:70	Wrapping Terminal Type-L	P=5 4P	L型ラッピング端子板			
	LA 00:53:30	SP Terminal	4P	スピーカーターミナル			
	LA 00:18:80	Fuse Hdder Pin	PC-FHI	ヒューズホルダーピン			
	LB 91:80:20	XH Base Pin I Model	2P	XHベースピンI型			
	LB 91:80:40	"	4P	"			
	AA 62:06:30	Switch Holder		スイッチホルダー			
	AA 62:06:40	VR Plste.	B 2 5 K Q	V R プレート			
	ED 33:00:66	Bind Head Screw	3×6 FCM3-BI	鉄バインド小ネジ	PACK		

B-2x

YAMAHA
