

Service Manual

QUARTZ Synthesizer FM/MW/LW Stereo Tuner

ST-5L

[EX], [EK], [EF], [EB]

ST-5L(K)

[EX], [EK]

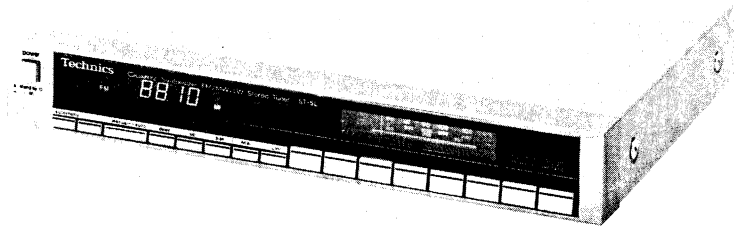

Areas

- * [EX] is available in Switzerland and Scandinavia.
- * [EK] is available in United Kingdom.
- * [EF] is available in France.
- * [EB] is available in Belgium.

* The cabinet and front panel are available in black color and silver types.

* The black type model is provided with (K) in the Service Manual.

Specifications

(Specifications are subject to change without notice for further improvement.)

(DIN 45 500)

■ FM TUNER SECTION

Frequency range	87.50~108.00 MHz
Sensitivity	1.0 μ V (IHF, usable)
(For United Kingdom)	
S/N 30 dB	2.0 μ V (300 Ω), 1.0 μ V (75 Ω)
S/N 26 dB	1.8 μ V (300 Ω), 0.9 μ V (75 Ω)
S/N 20 dB	1.6 μ V (300 Ω), 0.8 μ V (75 Ω)
(For others)	
S/N 30 dB	1.0 μ V (75 Ω)
S/N 26 dB	0.9 μ V (75 Ω)
S/N 20 dB	0.8 μ V (75 Ω)
IHF 46 dB stereo quieting sensitivity	22.0 μ V/75 Ω
Total harmonic distortion	
MONO	0.08%
STEREO	0.15%
S/N	
MONO	70 dB (78 dB, IHF)
STEREO	65 dB (73 dB, IHF)
Frequency response	20 Hz~15 kHz, +0.5 dB~ -1.5 dB
Alternate channel selectivity	
normal \pm 400 kHz	65 dB
Capture ratio	1.0 dB
Image rejection at 98 MHz	55 dB
IF rejection at 98 MHz	80 dB
Spurious response rejection at 98 MHz	80 dB
AM suppression	55 dB
Stereo separation	
1 kHz	40 dB
10 kHz	30 dB
Carrier leak	
19 kHz	-30 dB (-35 dB, IHF)
38 kHz	-45 dB (-50 dB, IHF)
Channel balance (250 Hz~6,300 Hz)	\pm 1.0 dB
Limiting point	1.9 μ V

Bandwidth

IF amplifier	180 kHz
FM demodulator	1000 kHz

Antenna terminals (For United Kingdom)

300 Ω (balanced)
75 Ω (unbalanced)
75 Ω (unbalanced)

(For others)

■ AM TUNER SECTION

Frequency range

MW	522~1611 kHz (9-kHz steps)
LW	530~1620 kHz (10-kHz steps)
	153~353 kHz (9-kHz steps)

Sensitivity (S/N 20 dB)

MW	20 μ V, 300 μ V/m
LW	50 μ V

Selectivity (\pm 9 kHz)

MW	55 dB
LW	55 dB

Image rejection at 999 kHz

MW	40 dB
LW (at 254 kHz)	40 dB

IF rejection at 999 kHz

MW	65 dB
LW (at 254 kHz)	35 dB

■ GENERAL

Output voltage	0.6V
Power consumption	9W
Power supply	
(For United Kingdom)	AC 50 Hz/60 Hz, 240V
(For others)	AC 50 Hz/60 Hz, 220V
Dimensions (W×H×D)	315 × 50 × 244 mm
	(12-13/32" × 1-31/32" × 9-9/32")
Weight	2.0 kg
	(4.4 lb.)

Technics

Matsushita Electric Trading Co., Ltd.
P.O. Box 288, Central Osaka Japan

CONTENTS

	Page		Page
LOCATION OF CONTROLS	2, 3	TERMINAL OPERATION OF PLL	
DISASSEMBLY INSTRUCTIONS	3 ~ 5	CONTROLLER (IC901)	11
CONNECTION TO AMPLIFIER	5	BLOCK DIAGRAM	12 ~ 14
AM LOOP ANTENNA	5	SCHEMATIC DIAGRAM	15 ~ 17
MEASUREMENTS AND ADJUSTMENTS	6, 7	EXPLODED VIEWS	18, 19
RESISTORS & CAPACITORS	8	REPLACEMENT PARTS LIST	20
CIRCUIT BOARDS AND			
WIRING CONNECTION DIAGRAM	9, 10		

LOCATION OF CONTROLS

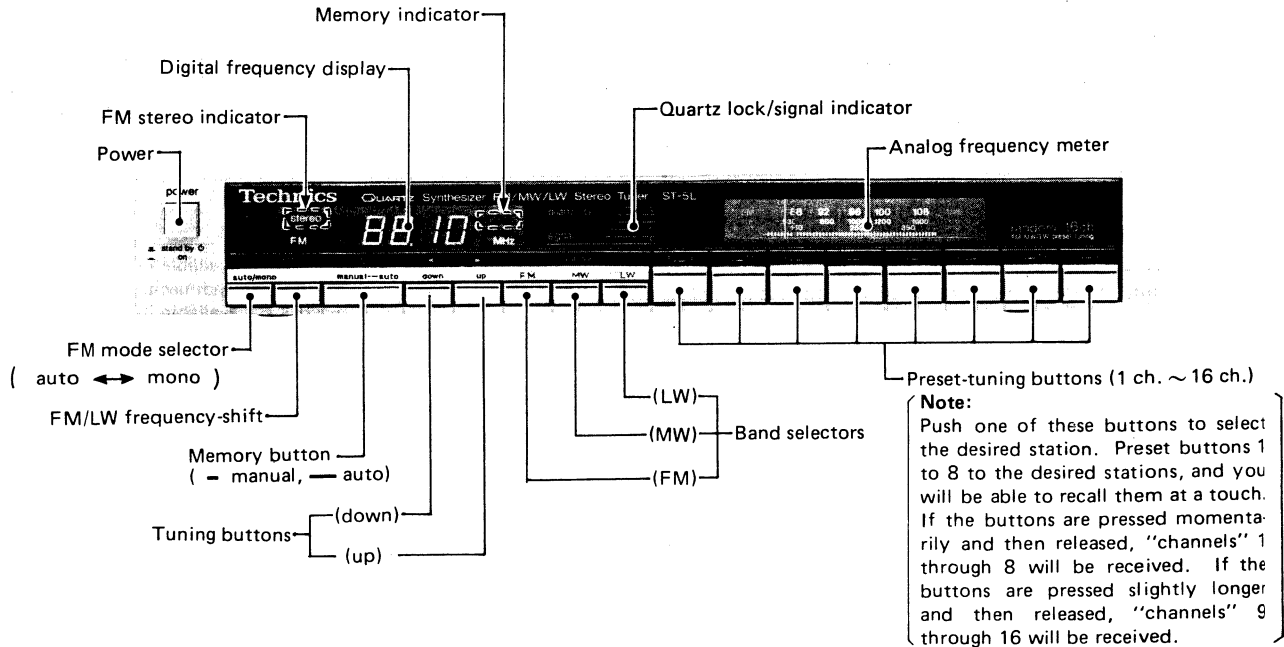

• Operation of FM/LW frequency-shift selector (freq. shift)

This switch is used to shift the reception frequency of the unit in accordance with the transmission frequency of the broadcasting station.

For FM broadcasts:

When the button is pressed, the reception frequency increases by 0.025 MHz (25 kHz). (Note, however, that the indication will only be 0.02 MHz.)

So, for example, to receive 98.025 MHz, tune to 98.00 MHz, and then press this button. Likewise, to receive 98.075 MHz, tune to 98.05 MHz, and then press this button.

In order to return to the original frequency indication, press this button again.

For LW broadcasts:

When this button is pressed, the reception frequency decreases by 0.002 MHz (2 kHz.)

So, for example, to receive 153 kHz, tune to 155 kHz, and then press this button.

In order to return to the original frequency indication, press this button again.

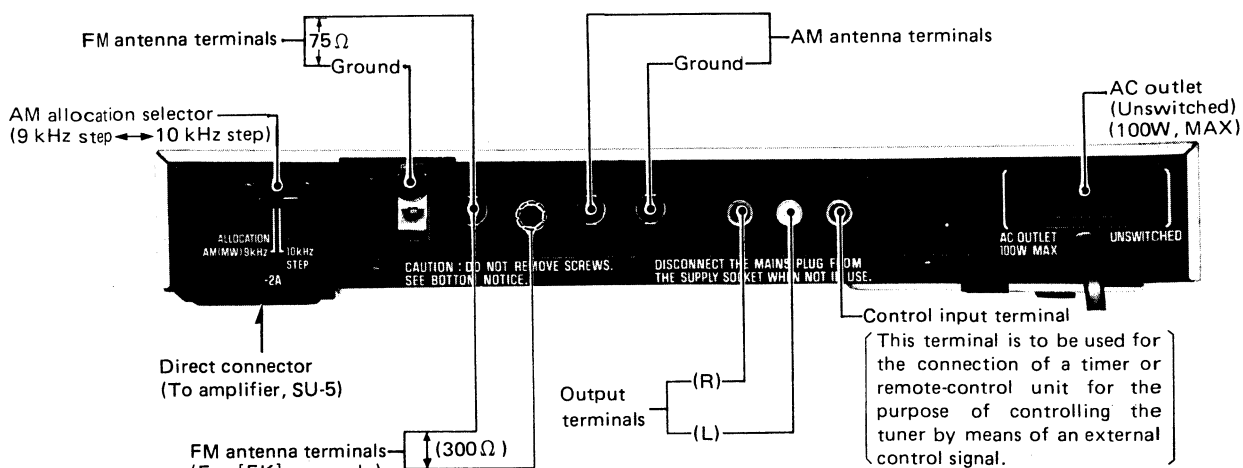

• The power supply for this unit varies depending upon the areas.

2 Also, the parts used for power supply are different.

* 220V (50/60 Hz) for Continental Europe,

* 240V (50/60 Hz) for United Kingdom.

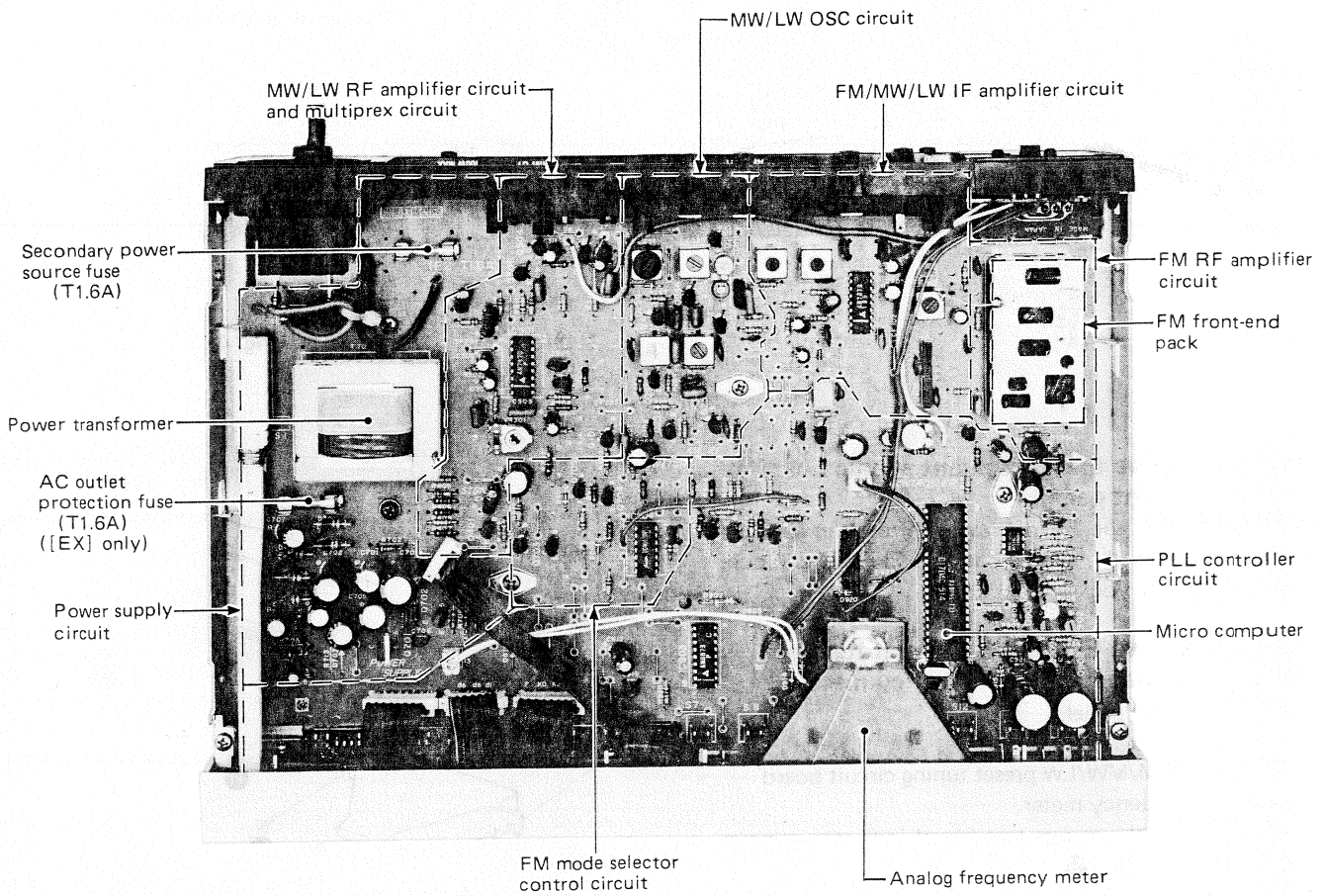

■ DISASSEMBLY INSTRUCTIONS

Note: When repairing the FM front-end pack, replace it with the adjusted part for repair.

(1) How to remove the front panel

1. Remove the 4 setscrews (① ~ ④ in Fig. 1) of the cabinet.
2. Move the cabinet in the direction of the arrow **A** in the Fig. 1.
3. Disconnect the 6 leads (Fig. 2 : **A** ~ **F**) connected from the front panel to the set.
4. Remove the 4 setscrews (Fig. 1 : ⑤, ⑥ Fig. 2 : ⑦, ⑧) of the front panel.
Then remove the front panel as shown in Fig. 3.

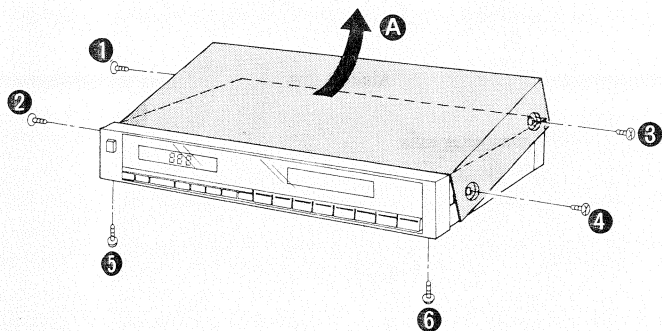

[Fig. 1]

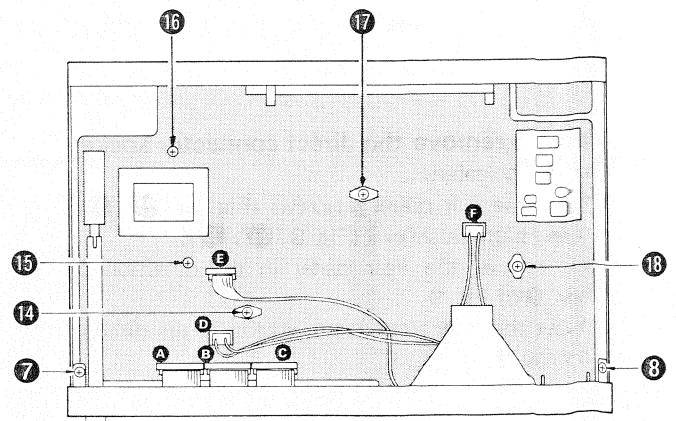

[Fig. 2]

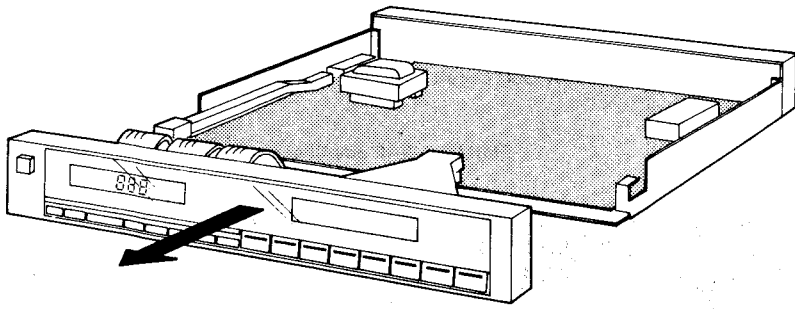

[Fig. 3]

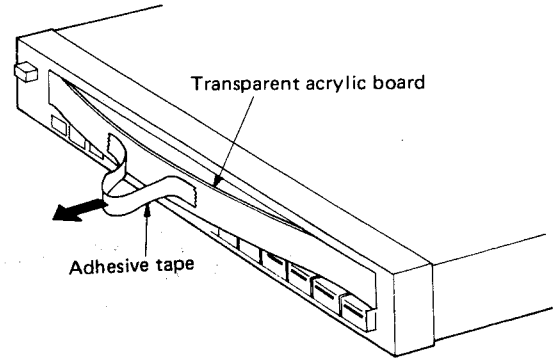

[Fig. 4]

(2) How to remove the transparent acrylic board at FL of the front panel.

When removing the FL display tube to clean it, stick adhesive tape to the acrylic board as in Fig. 4 and pull the tape toward you.

(3) How to remove FM/MW/LW preset-tuning circuit board and analog frequency meter.

1. Remove the front panel.
2. Remove the 4 setscrews (Fig. 5 : 9, 10, 12, 13) used to secure the FM/MW/LW preset tuning circuit board and analog frequency meter.
3. When removing the quartz lock/signal indicator, remove the setscrew (Fig. 5 : 11).

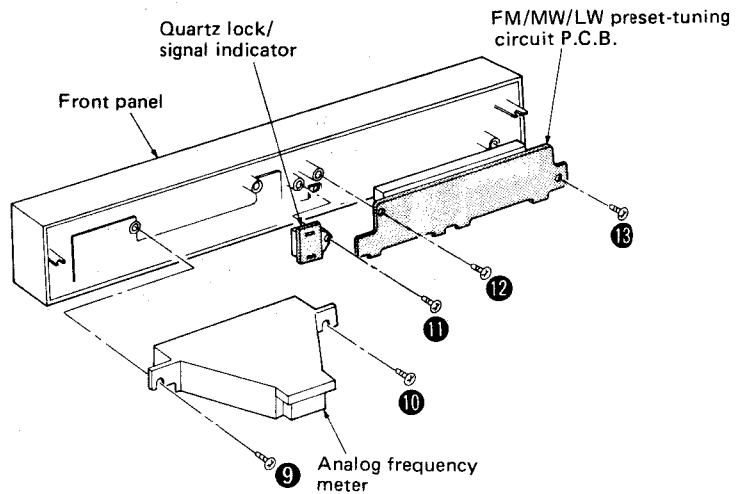

[Fig. 5]

(4) How to remove the main P.C.B.

1. Remove the front panel.
2. Remove the 5 setscrews (Fig. 2 : 14 ~ 18).
3. Remove the 2 setscrews (Fig. 6 : 19, 20) of the terminal plate, and remove the main P.C.B. as in Fig. 7.
4. When mounting the main P.C.B., completely fit the main P.C.B. onto the spacer and secure it with the setscrews.

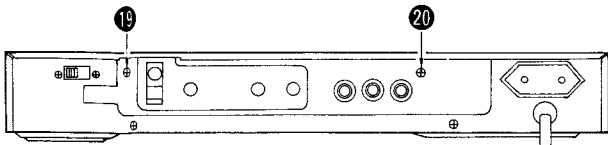

[Fig. 6]

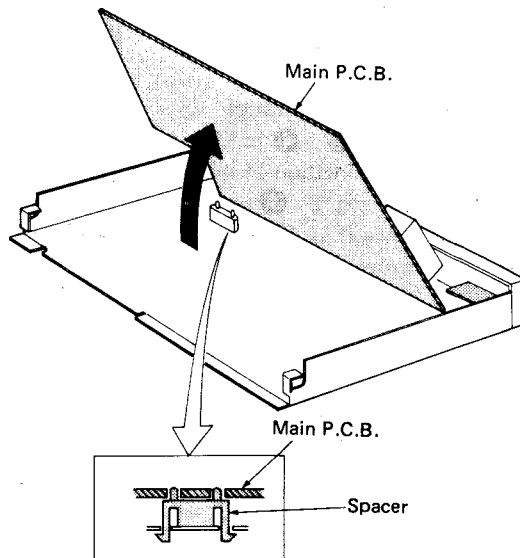

[Fig. 7]

(1) How to remove the direct connector socket

1. Remove the cabinet.
2. Remove the rear panel setscrews (Fig. 8 : 21, 22) and terminal plate setscrews (Fig. 8 : 23, 24). Then remove the rear panel in the direction of the arrow B of Fig. 9.
3. Remove the direct connector socket in the direction of the arrow C of Fig. 9.

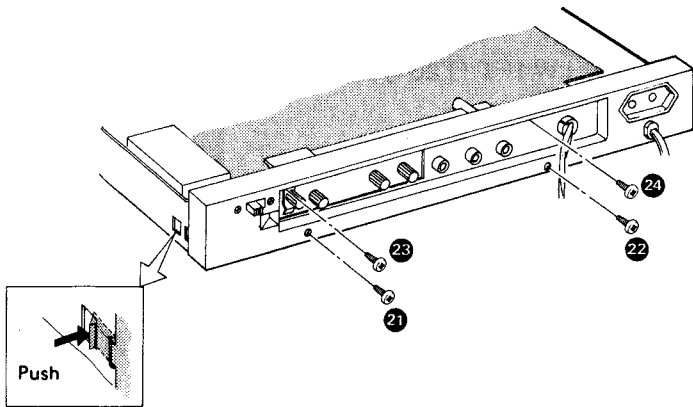

[Fig. 8]

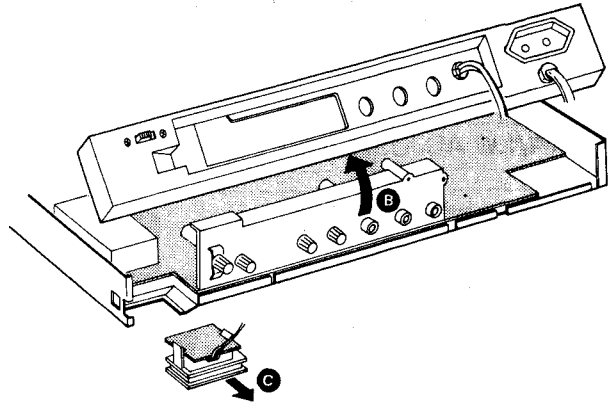

[Fig. 9]

■ CONNECTION TO AMPLIFIER

When Stacking the Units Vertically, connect using direct connectors.

- ① Lift the direct connector on the amplifier and move the stabilizing pin from the back panel to the upper surface.
- ② Connect the power cord of the tuner to the AC outlet of the amplifier.

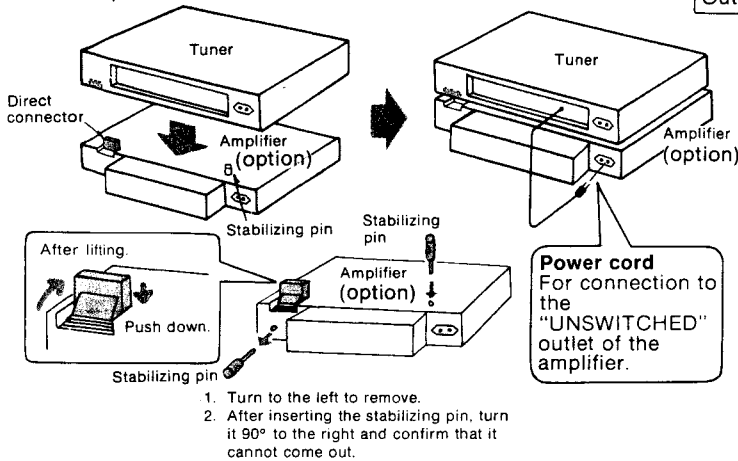

When Placing the Units Side by Side, connect them using the pin cords.

- ① Connect the amplifier to the tuner using the pin cord
- ② Connect the power cord of the tuner to the AC outlet of the amplifier.

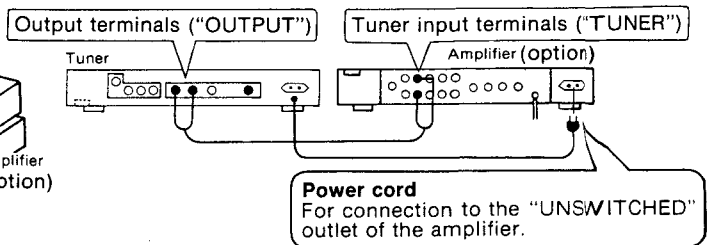

Note:

1. Be sure to connect the power cord of the tuner to the "UNSWITCHED" power outlet of the amplifier (SU-5) to be used.
2. If the power supply is interrupted for one week or longer, the memory settings will be erased. The memory in this unit is maintained by a gold capacitor. If the power supply is interrupted for a week or longer, set the power switch of the tuner to the "on" position for thirty minutes or more in order to recharge the gold capacitor.

■ AM LOOP ANTENNA

Since the unit does not employ the conventional AM bar antenna, be sure to connect the AM loop antenna to the AM antenna terminal on the back of the set when receiving AM antenna terminal. When the AM loop antenna is connected to the rear panel, place it as far away from the set as possible to improve the sensitivity.

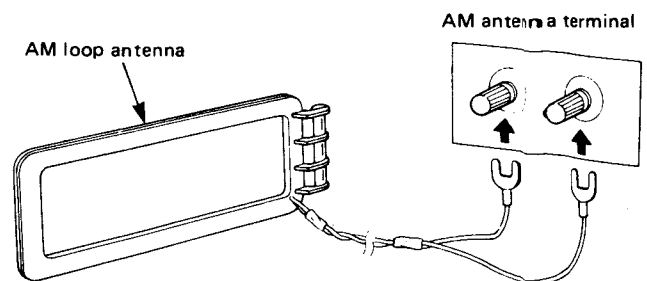

Precautions for attachment

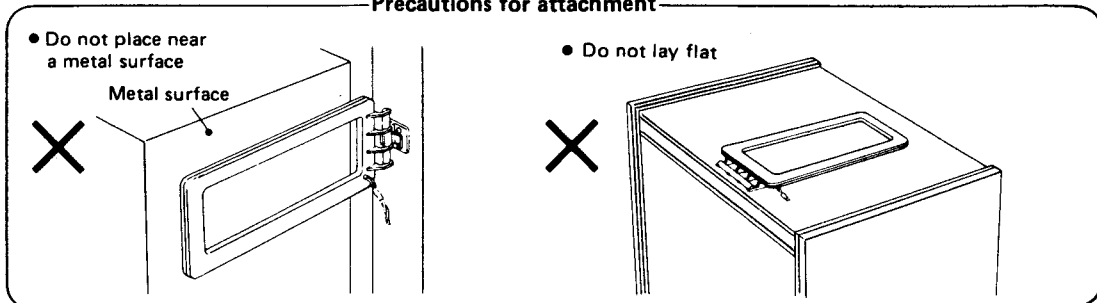

Step No.	FM SIGNAL GENERATOR		DISPLAY FREQUENCY	PREPARATIONS	PARTS ADJUSTED	ADJUSTING PROCEDURE
	CONNECTION	FREQUENCY				
FM ANALOG FREQUENCY METER						
8	—	No-Signal	108.0 MHz	—	VR901 (Frequency meter)	<ol style="list-style-type: none"> Adjust VR901 so that the frequency meter indicates 108.0 MHz. (Refer to Fig. 12) Next operate the tuning button so that 88.1 MHz and 100.1 MHz are indicated in the digital frequency display. Then make sure that the indicator is in contact with each letter. If the requirement in step 2 is not satisfied, go back to step 1 and adjust the indicator within the dotted line of Fig. 12.

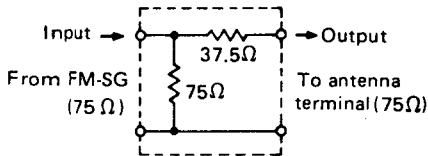

[Fig. 10]

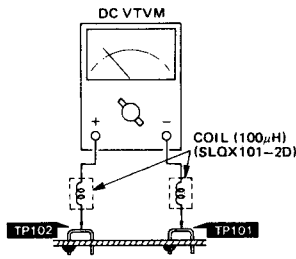

[Fig. 11]

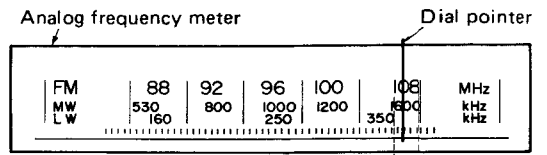

[Fig. 12]

● About test point

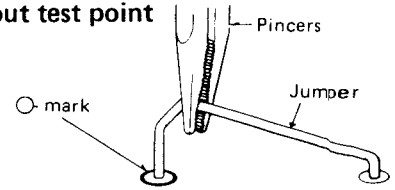

It can be removed by pulling the ○-marked side by use of pincers. Insert it into the original hole when not needed.

[Fig. 13]

● Adjustment points

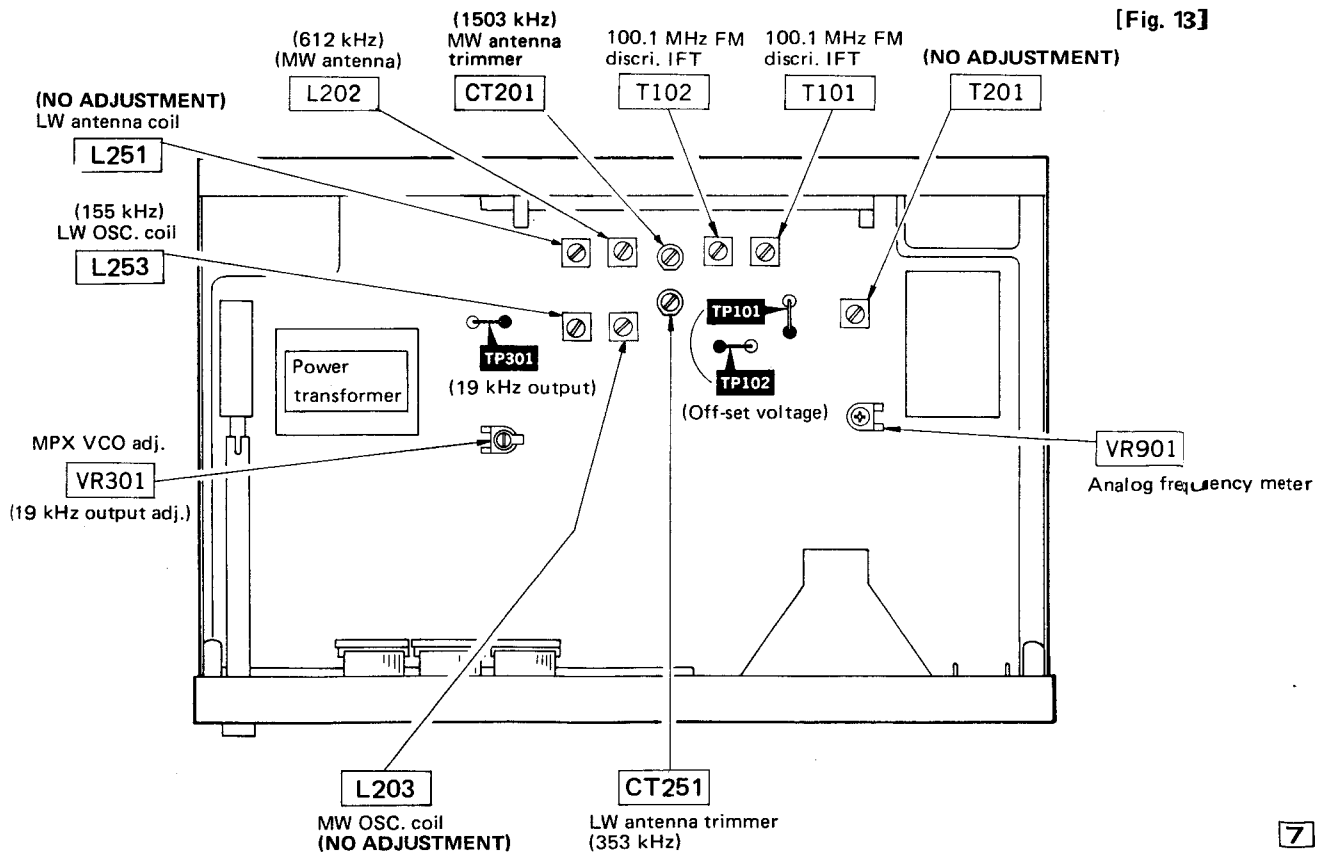

• Digital frequency display tube (FL)

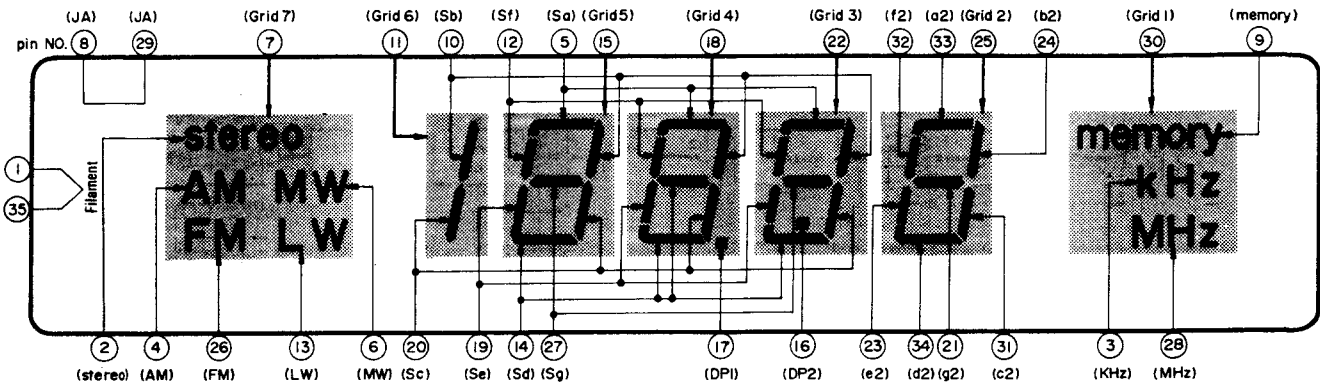

RESISTORS & CAPACITORS

- Notes:**
- Part numbers are indicated on most mechanical parts. Please use this part number for parts orders.
 - Important safety notice: Components identified by Δ mark have special characteristics important for safety. When replacing any of these components use only manufacturer's specified parts.
 - The "S" mark is service standard parts and may differ from production parts.
 - Unless otherwise specified. All resistors are in OHMS (Ω) K = 1000 Ω , M = 1000k Ω . All capacitors are in MICROFARADS (μ F) P = μ F

Numbering System of Resistor

Example	25	F	J	101
ERD	Wattage	Shape	Tolerance	Value

Numbering System of Capacitor

Example	1H	102	Z	F
ECKD	Voltage	Value	Tolerance	Peculiarity
ECEA	50	M	R47	R
Type	Voltage	Peculiarity use	Value	Special use

Resistor Type	Wattage	Tolerance
ERD : Carbon	12 : 1/2W	J : \pm 5%
ERQ : Fuse Type Metal	25 : 1/4W	

Capacitor Type	Voltage		Tolerance
	ECEA Type	Other	
ECEA : Electrolytic	0J : 6.3V	1H : 50V DC	C : \pm 0.25 μ F
ECCD : Ceramic	1A : 10V	2H : 500V DC	J : \pm 5%
ECKD : Ceramic	1C : 16V	2R3 : 2.3V DC	K : \pm 10%
ECQM : Polyester	1E : 25V		Z : +80%, -20%
ECQP : Polypropylene	1H : 50V		
EECW : Liquid electrolyte double layer capacitor	50 : 50V		
	25 : 25V		

Ref. No.	Part No.	Value
RESISTORS		
R1	S ERD25TJ104	100K
R2	S ERD25TJ273	27K
R3	S ERD25FJ151	150
R102	S ERD25FJ331	330
R103	S ERD25FJ102	1K
R104	S ERD25FJ471	470
R105	S ERD25FJ102	1K
R106	S ERD25FJ472	4.7K
R107	S ERD25FJ272	2.7K
R108	S ERD25FJ471	470
R109	S ERD25TJ104	100K
R201	S ERD25TJ104	100K
R203	S ERD25FJ102	1K
R204	S ERD25TJ684	680K
R206	S ERD25FJ102	1K
R251	S ERD25TJ473	47K
R252	S ERD25TJ563	56K
R253	S ERD25FJ182	1.8K
R254	S ERD25FJ332	3.3K
R255, 256	S ERD25FJ562	5.6K
R257	S ERD25TJ153	15K
R258	S ERD25FJ562	5.6K
R260	S ERD25TJ333	33K
R301	S ERD25TJ393	39K
R302	Δ S ERD25FJ151	150
R303, 304	S ERD25TJ223	22K
R305	S ERD25TJ274	270K
R306	S ERD25TJ153	15K
R307	S ERD25FJ102	1K
R310, 311	S ERD25FJ332	3.3K
R312, 313	S ERD25TJ333	33K
R401	S ERD25FJ182	1.8K
R402	S ERD25FJ562	5.6K
R403	S ERD25FJ821	820
R404	S ERD25FJ331	330
R405	S ERD25FJ151	150
R406	S ERD25FJ121	120
R407	S ERD25FJ100	10
R408	S ERD25FJ122	1.2K
R501	S ERD25TJ153	15K
R502	S ERD25TJ104	100K
R503	S ERD25TJ563	56K

Ref. No.	Part No.	Value
R504	S ERD25TJ473	47K
R505	S ERD25TJ393	39K
R506	S ERD25TJ104	100K
R507	S ERD25TJ473	47K
R508, 509	S ERD25TJ563	56K
R511	S ERD25FJ102	1K
R512	S ERD25TJ104	100K
R513	S ERD25FJ103	10K
R514	S ERD25TJ104	100K
R701	S ERD25FJ122	1.2K
R702	Δ S ERD25FJ688	6.8
R703	S ERD25FJ471	470
R704	Δ S ERD25FJ2R2	2.2
R705	Δ S ERQ12HJ100	10
R706	S ERD25FJ472	4.7K
R707	S ERD25FJ392	3.9K
R709	S ERD25FJ391	390
R710	S ERD25TJ473	47K
R711	S ERD25FJ103	10K
R712	S ERD25TJ473	47K
R901	S ERD25FJ681	680
R902	S ERD25FJ103	10K
R903	S ERD25FJ472	4.7K
R904	S ERD25FJ562	5.6K
R905	S ERD25FJ102	1K
R906	S ERD25FJ561	560
R908	S ERD25FJ682	6.8K
R909	S ERD25TJ123	12K
R910	S ERD25FJ682	6.8K
R912	S ERD25TJ104	100K
R913	S ERD25TJ684	680K
R914	Δ S ERD25FJ101	100
R915	S ERD25FJ103	10K
R916	S ERD25TJ184	180K
R917	S ERD25TJ224	220K
R919	S ERD25FJ103	10K
R920	S ERD25FJ102	1K
R921, 922	S ERD25TJ104	100K
R926	S ERD25TJ104	100K

Ref. No.	Part No.	Value
R927	S ERD25TJ333	33K
R931	S ERD25FJ102	1K
R932	S ERD25FJ472	4.7K
R933	S ERD25FJ471	470
R934	S ERD25TJ153	15K
R935	S ERD25FJ222	2.2K
CAPACITORS		
C1	S ECEA50Z3R3	3.3
C2	S ECKD1H103ZF	0.01
C4	S ECKD1H103ZF	0.01
C5	S ECEA1ES101	100
C101	S ECKD1H103ZF	0.01
C103	S ECKD1H103ZF	0.01
C105, 106	S ECKD1H223ZF	0.022
C107	S ECKD1H223ZF	0.022
C108	S ECEA50Z1	1
C109, 110	S ECEA1HS100	10
C111	S ECKD1H223ZF	0.022
C112	S ECCD1H101K	100P
C202	ECQM1H473KV	0.047
C204	ECQP1471JZ	470P
C205	S ECEA1AS101	100
C206	S ECEA25Z4R7	4.7
C207	S ECQM1H183JZ	0.018
C208	S ECCD1H390K	39P
C209	S ECKD1H103ZF	0.01
C251	S ECKD1H223ZF	0.022
C252	S ECKD1H103ZF	0.01
C253	S ECKD1H223ZF	0.022
C254	S ECQM1H223JZ	0.022
C255	S ECQP1271JZ	270P
C256, 257	S ECKD1H223ZF	0.022
C258	S ECCD1H050CC	5P
C259	S ECQM1H223JZ	0.022
C260	S ECCD1H101KC	100P
C262	S ECEA1ES101	100
C301	S ECEA1HS100	10
C302	S ECEA1CS221	220

Ref. No.	Part No.	Value
C303	ECQM1H473KV	0.047
C305	ECQP1471JZ	470P
C306	S ECEA50Z1	1
C307	S ECEA50Z3R3	3.3
C308	S ECEA50Z4R7	0.47
C309, 310	S ECQM1H153JZ	0.015
C311, 312	S ECEA50Z4R7	0.47
C401	S ECEA50Z3R3	3.3
C501	S ECEA50Z1	1
C701	S ECEA1CS331	330
C702	S ECEA1CS471	470
C703	S ECKD2H681KB	680P
C704	S ECEA1VS471	470
C705	S ECEA1CS471	470
C706	S ECKD1H103ZF	0.01
C707	S ECEA1VS470	47
C708	S ECEA1HS470	47
C709, 710	S ECKD2H681KB	680P
C711	S ECEA1HS470	47
C712	S ECEA1VS101	100
C901	S ECEA0JS102	1000
C902	S ECCD1H070CC	7P
C903	S ECKD1H180K	18P
C904	S ECKD1H103ZF	0.01
C906, 907	S ECKD1H103ZF	0.01
C908	S ECKD1H103ZF	0.01
C909	S ECEA50M4R7R	4.7
C910	S ECKD1H103ZF	0.01
C912	S ECEA1AS211	100
C913	S ECEA50Z3R3	3.3
C914, 915	S EECW2R3A3R3	3.3
C916	S ECEA1ES101	100
C917	S ECEA50Z4R7	4.7
C918	S ECEA1AS221	220
C919, 920	S ECKD1H103ZF	0.01
C931	S ECKD1H223ZF	0.022
C932	S ECEA50Z3R3	0.33
C933	S ECKD1H223ZF	0.022

Ground (Earth) lines

CIRCUIT BOARDS AND WIRING CONNECTION DIAGRAM

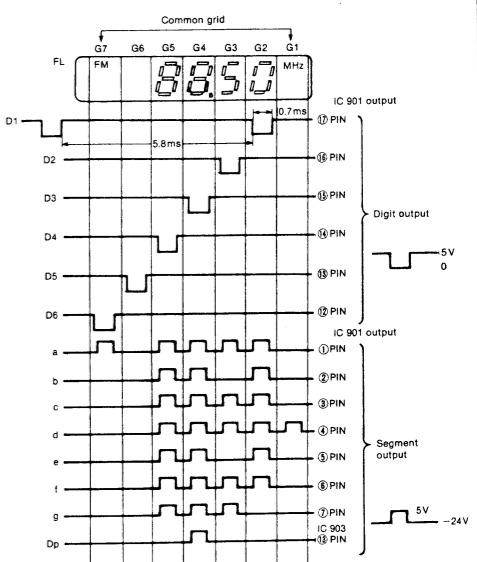
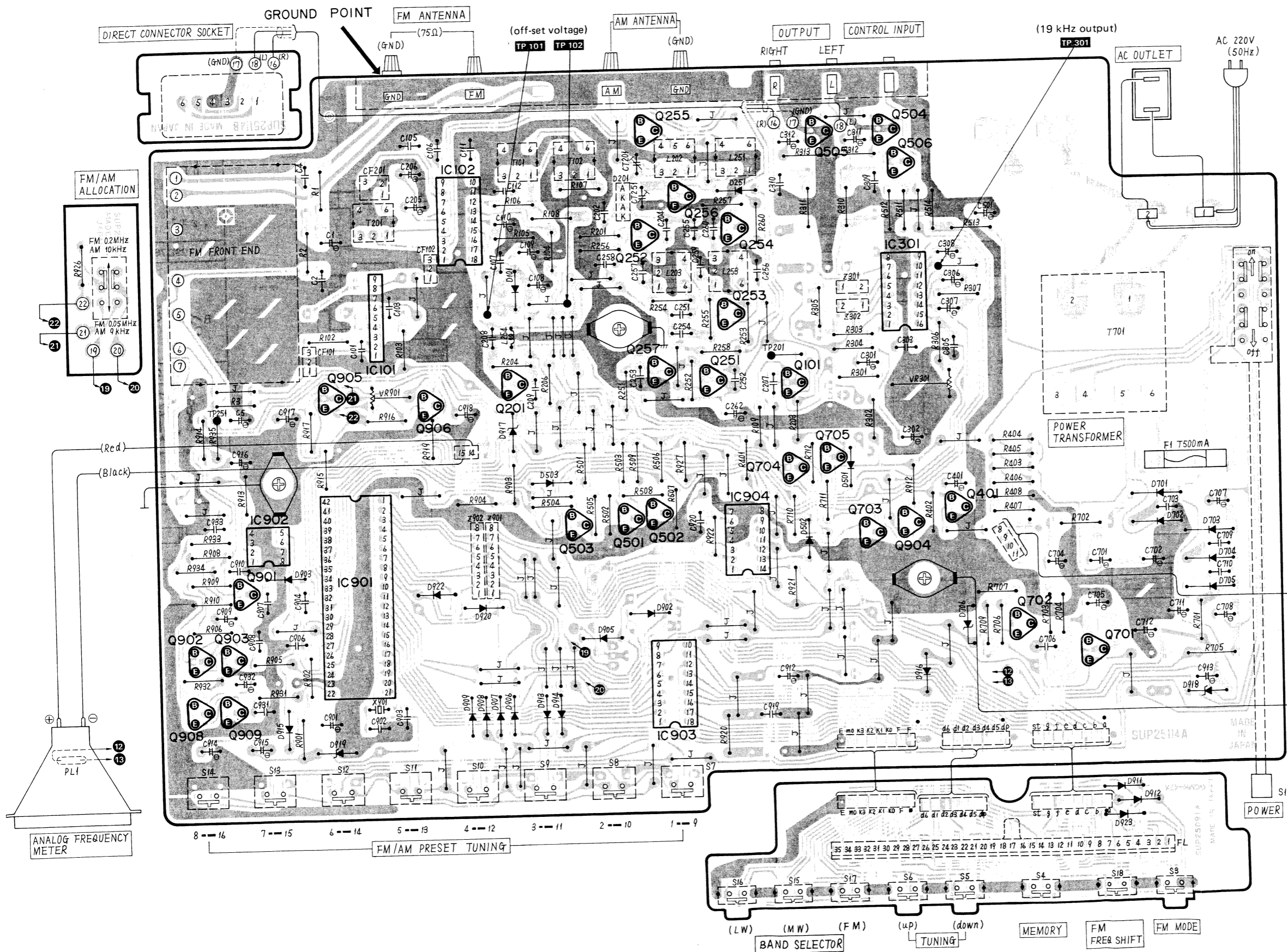

[Fig. 14]

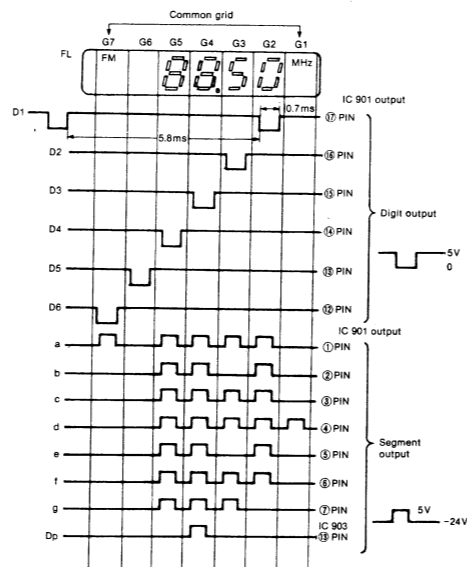
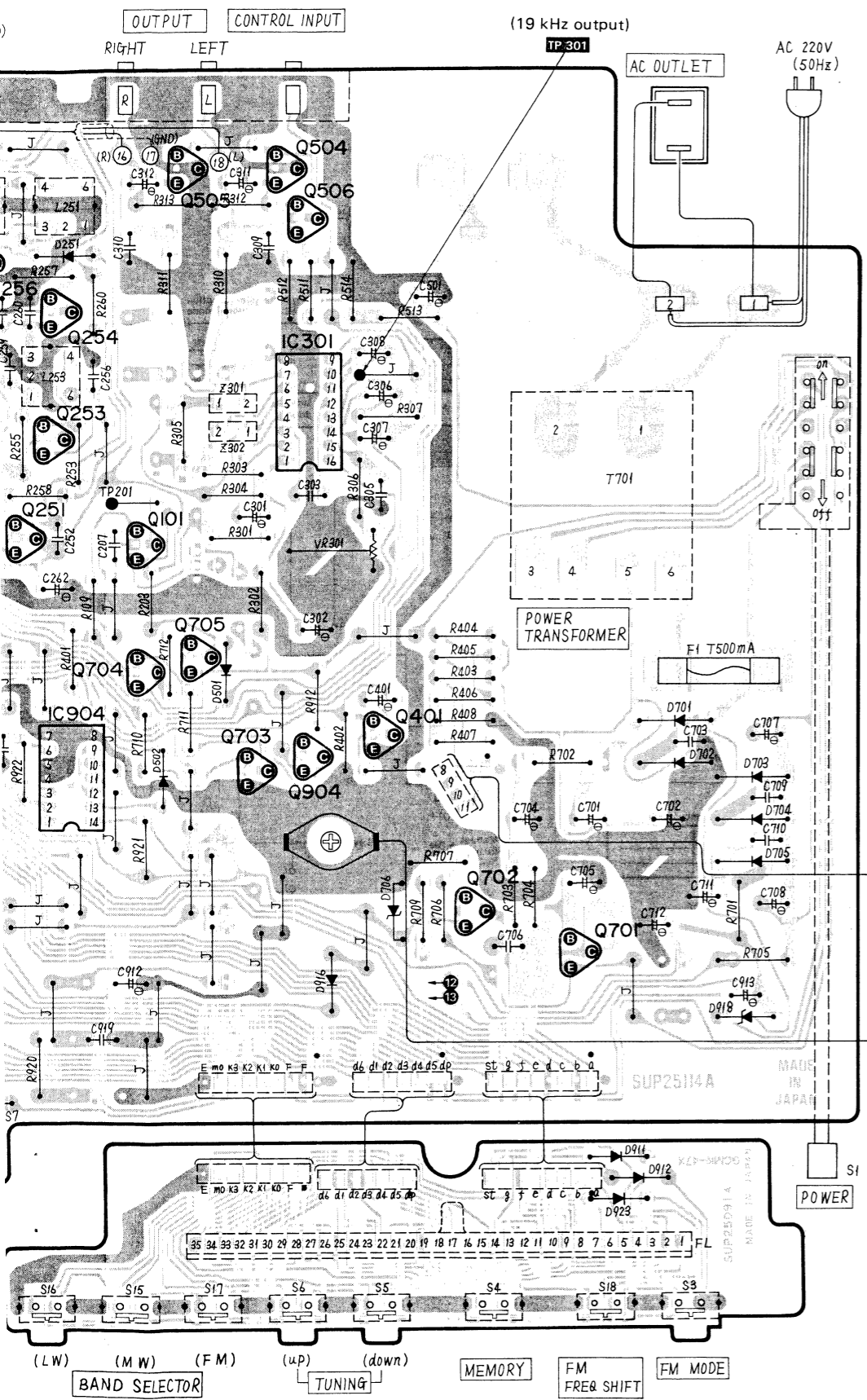

Pin No.
1
2
3
4
5
6
7
8
9
10
11
12
13
14
15
16
17
18
19
20
21
22
23
24
25

Ground (Earth) lines

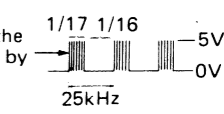

[Fig. 14]

TERMINAL OPERATION OF PLL CONTROLLER (IC901)

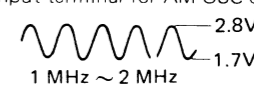
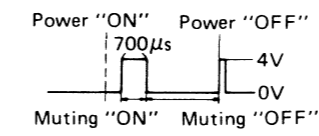
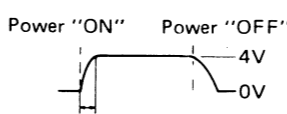
Pin No.	Mark	Description of terminal	Pin No.	Mark	Description of terminal	
1	Sa	Segment signal output terminal for display. (Refer to Fig. 14)	26	SD	This input terminal detects the reception of a broadcasting station. The voltage is 4.2V during reception, and otherwise 0V.	
2	Sb		27	FM	Input terminal for FM OSC output frequency-divided to 1/16 or 1/17 by pre-scaler.	
3	Sc		28	FSC	This is the terminal to deliver the frequency dividing ratio changeover output signal to the pre-scaler. The terminal continues to produce pulses at the rise of the signal applied to FM terminal (27) until the content of the inside swallow counter is 0. When the swallow counter comes to 0, the terminal level becomes low, then the frequency dividing ratio of pre-scaler is 1/16. Pulses two times larger than the value that cannot be divided by VCO/16. 	
4	Sd		Input terminal for key return signal from external key matrix. The output of segment terminals (a ~ g) is used as the key return signal source. 	29	INT	This is the interrupt demand signal input terminal. The signal from the control input terminal is put into this terminal, demanding for interruption, then the flow of program will be unconditionally shifted to the address No. 1.
5	Se			30	AM	Input terminal for AM OSC output. 
6	Sf			This is the output terminal to eliminate shock noise due to unlocking at PLL. When the CE terminal is at low level, the output from this terminal is at high level. Power "ON" Power "OFF"  Muting "ON" Muting "OFF"	31	PC2
7	Sg		32		PC3	
8	K0	Digit signal output terminal for display. (Refer to Fig. 14)	33	PB0	This is 4-bit input/output port. PB1 (34) terminal is the MW/LW selector output terminal, which is 5V in LW, and 0V in MW. PB2 (35) terminal is the FM/MW/LW selector output terminal, which is 5V in FM, and 0V in MW and LW. PB3 (36) terminal is the analog frequency meter selector output terminal, which is 5V in MW and LW, and 0V in FM.	
9	K1		34	PB1		
10	K2	35	PB2			
11	K3	36	PB3			
12	D6	This is the selected signal input terminal of the device. When operating the device, make the level high, and when it is not used, make the level low. When this terminal is at low level, all the segment (a ~ g) and digits (D1 ~ D6) terminals are off, but the memory is held. Power "ON" Power "OFF"  The device does not operate during this period.	37	PA0	This is 4-bit input/output port. (Not used in this unit)	
13	D5		38	PA1		
14	D4		39	PA2		
15	D3		Connecting terminal for crystal oscillator. The crystal connected is at 4.5 MHz.	40	PA3	One-bit input/output port. (Not used in this unit.)
16	D2	41		PD3		
17	D1	Power supply terminal of the device.	42	VDP	One-bit output port. Output signal is emitted to operate the analog frequency meter, and the output voltage varies according to the frequency.	
18	MT		23	GND	Ground terminal.	
19	X2	When the divided oscillation frequency is higher than the standard frequency, H-level output is delivered from these terminals. When it is lower, L-level (0V) output is delivered. When they coincide, it results in floating.	24	E02	When the divided oscillation frequency is higher than the standard frequency, H-level output is delivered from these terminals. When it is lower, L-level (0V) output is delivered. When they coincide, it results in floating.	
20	X1		25	CE		

■ BLOCK DIAGRAM

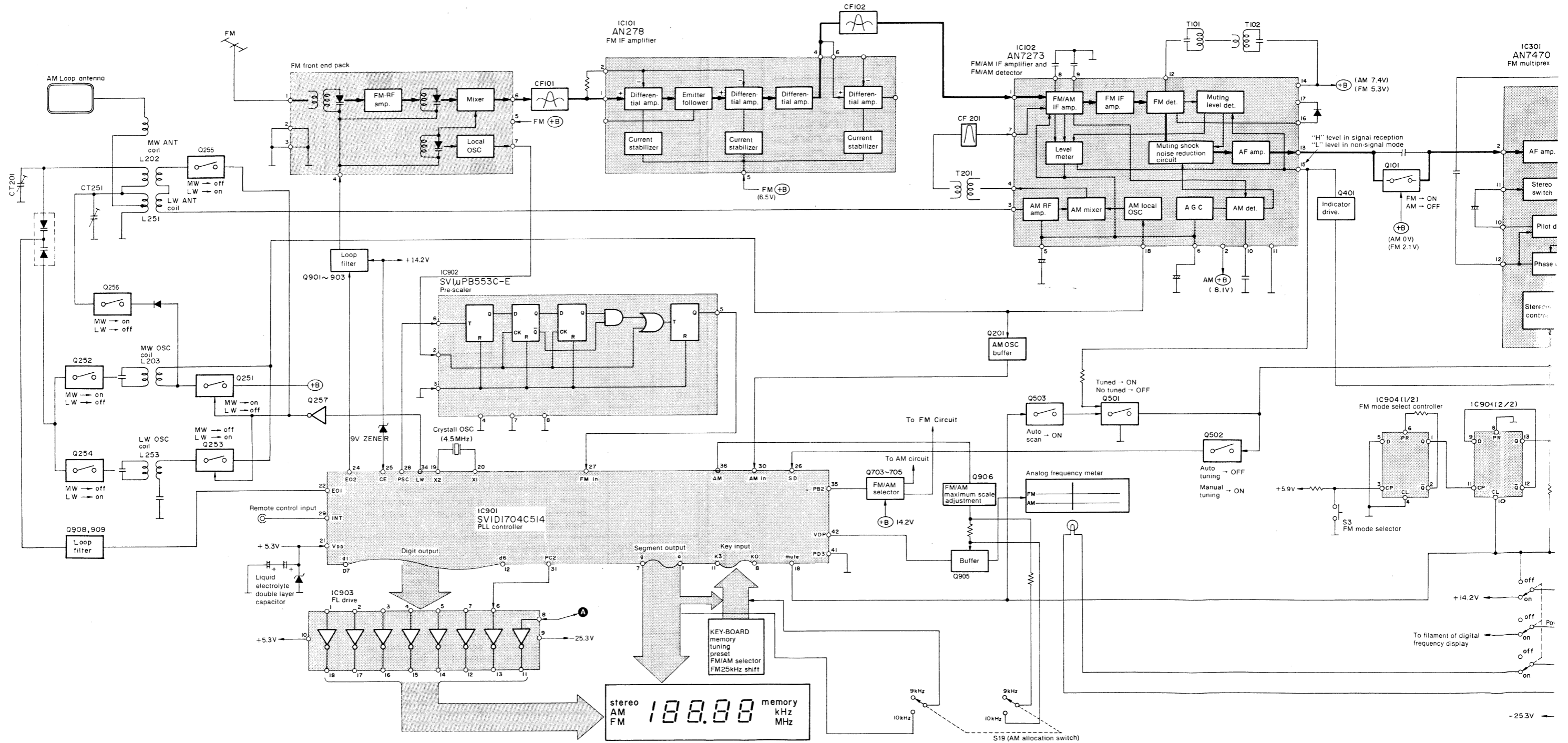

• Terminal guide of transistors, diodes and IC's

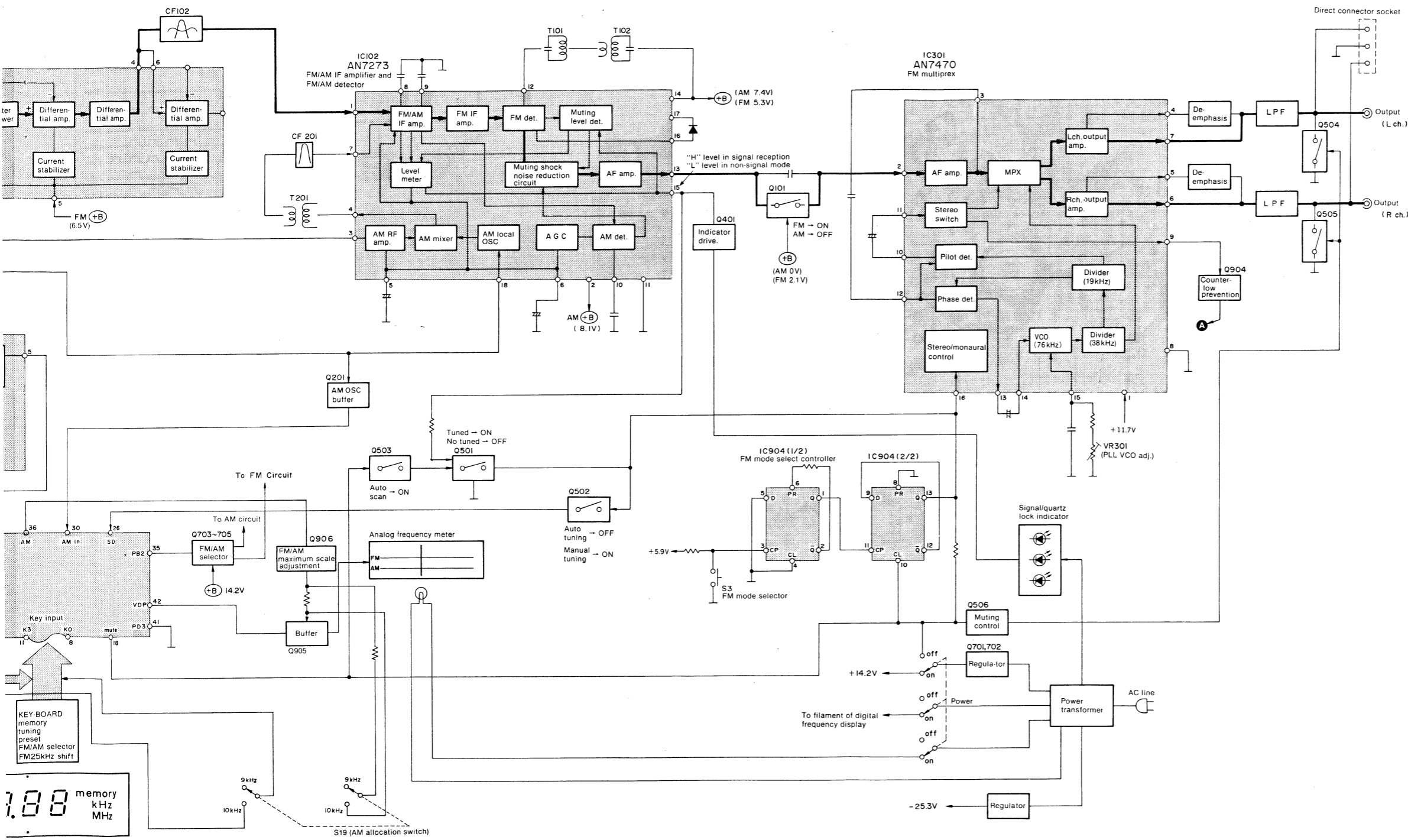

	AN7273 AN6873 SV1D1704C514 SV1UPC1161C3 SV1TC4013BP SV1UPB553AC	18 pin 42 pin 16 pin 14 pin 8 pin
	AN278	2SC1685, 2SA722
	2SD762	MA27W-A
	SVDKV1236Z	MA162A
	SVDSR1K2	SVDMZ

SCHEMATIC DIAGRAM

(This schematic diagram may be modified at any time with the development of new technology.)

The part No. of transistors, IC and diodes mentioned in the schematic diagram stand for production part No. Regarding the part No. with \odot mark, the production part No. are different from the replacement part No. Therefore, when placing an order for replacement part, please use the part No. in the replacement part list.

Note:

1. **S1** : Power source switch in "on" position.
2. **S3** : FM mode switch. (auto \leftrightarrow mono)
3. **S4** : Memory set switch. (manual \leftrightarrow auto memory)
4. **S5** : Tuning (down) switch. (manual \leftrightarrow auto)
[down : tuning to lower frequency]
5. **S6** : Tuning (up) switch. (manual \leftrightarrow auto)
[up : tuning to higher frequency]
6. **S7 ~ S14** : Preset tuning switch.
* With it lightly pushed (less than 0.4 sec.) and released, the 1 ~ 8 CH (front stations) are received.
* With it continuously pushed (0.4 sec. or more) and released, the 9 ~ 16 CH (back stations) are received.
7. **S15** : MW selector switch.
8. **S16** : LW selector switch.
9. **S17** : FM selector switch.
10. **S18** : FM/LW shift switch. (off \leftrightarrow FM 25 kHz/LW 2 kHz)
11. **S19** : AM (MW) allocation switch in "9 kHz step" position.
9 kHz step \leftrightarrow 10 kHz step

12. Indicated voltage values are the standard values for the unit measured by the DC electronic circuit tester (high-impedance) with the chassis taken as standard. Therefore, there may exist some errors in the voltage values, depending on the internal impedance of the DC circuit tester.
* Figures in \square stand for DC voltage in FM signal (no signal) reception mode.
* Figures in \square stand for DC voltage in FM stereo signal reception mode.
* Figures in () stand for DC voltage in MW signal reception mode.
* Figures in [] stand for DC voltage in LW signal reception mode.

13. Positive voltage lines
- AF signal lines
- FM signal
- FM IF
- AM signal
- AM IF

14. Important safety notice.
Components identified by Δ mark have special characteristics important for safety. When replacing any of these components, use only manufacturer's specified parts.

Use of ceramic filters in pairs

The ceramic filters (CF101, CF102) for FM-IF circuit are available in two ranks. For this machine, be sure to use the ceramics of the same rank in a pair.

At repairing and replacement, pay close attention to the diode (D902) for use as different diodes must be used depending on each rank of the ceramic filters.

Color marking (Red or Black)

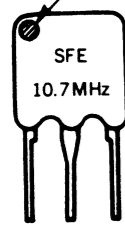

RANK (Color)	D902	CENTER FREQUENCY
Red	X	10.70 MHz
Black	O	10.65 MHz

Note: \circ Mark Diode is used.
 \times Mark Diode is not used.

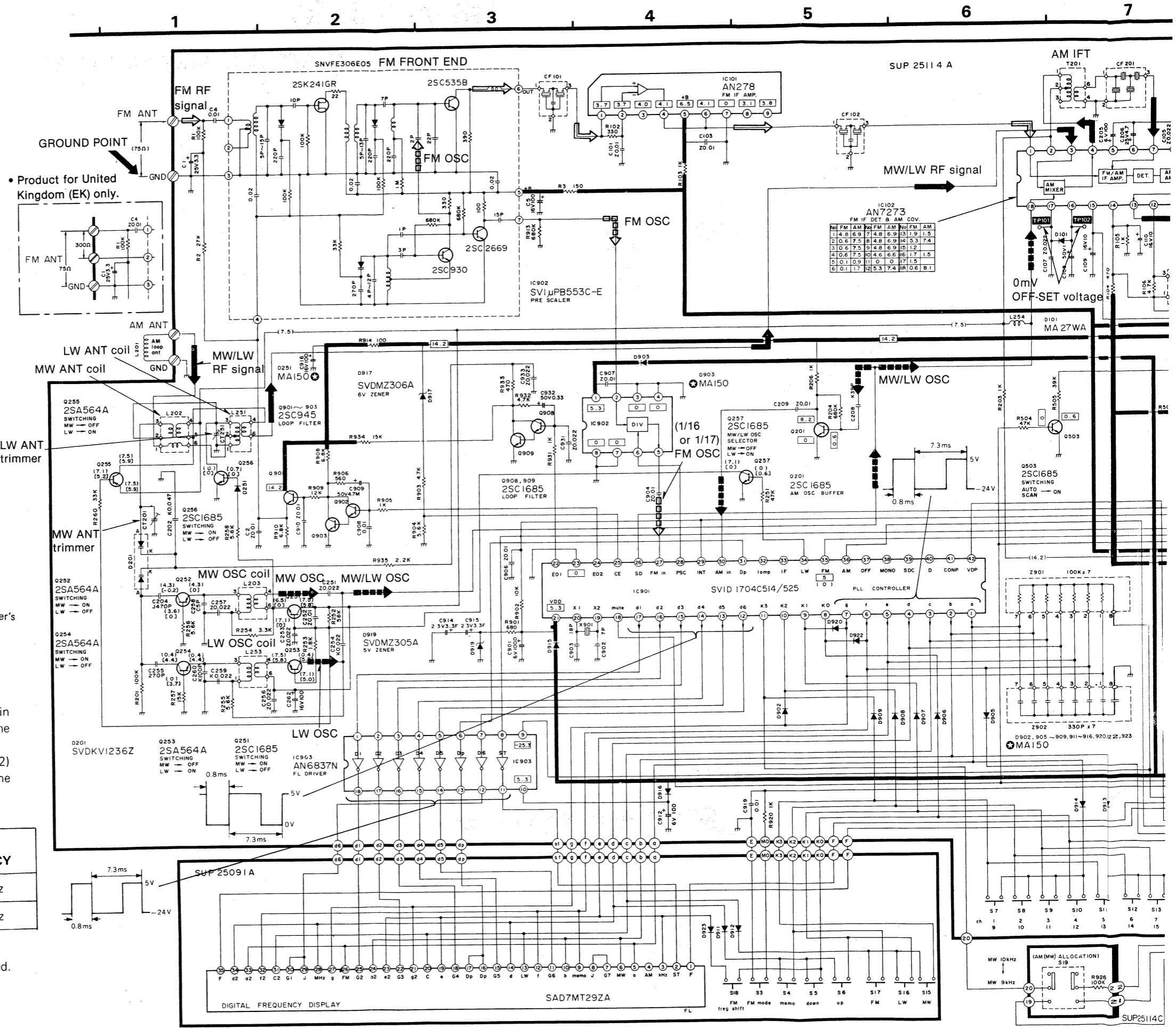

REPLA

- Notes: 1. Part n
Please
2. Impor
Comp
charac
When
manu'
3. -
Omar
4. Part c
both t

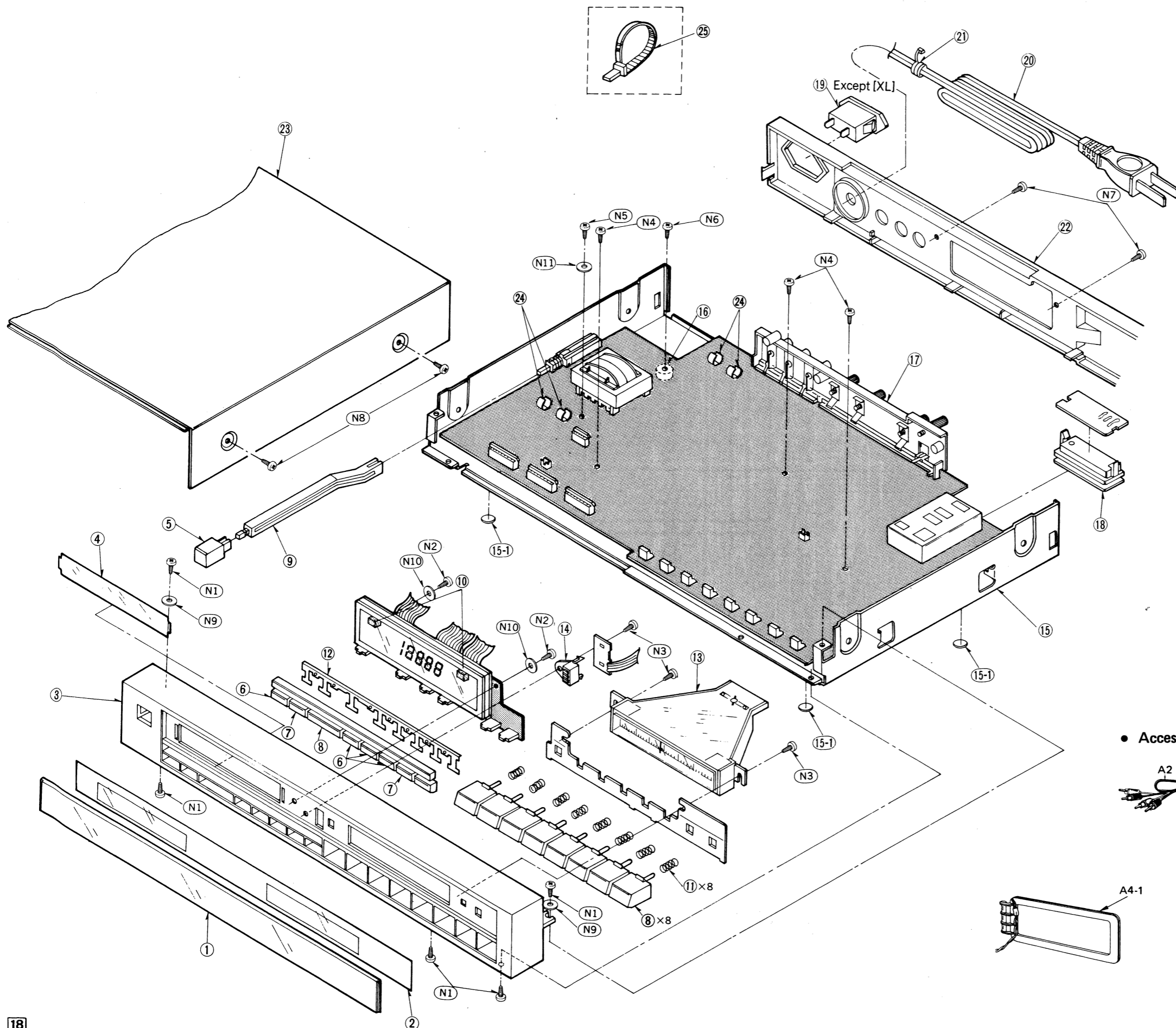

Ref. No.	Part No.	Description
INTEGRATED CIRCUITS		
IC101	AN278	FM IF Amplifier
IC102	AN7273	FM IF Amplifier
IC301	SVIUPC1161C3	FM/AM Detector
		FM MPX (Product Part No. is AN7470)
IC901	SVID1704C525	PLL Controller
IC902	SVIUPB553AC	Pre-Scaler
IC903	AN6873N	FL Driver
IC904	SVITC4013BP	FM Mode Select Controller
TRANSISTORS		
Q101, 201	S 2SC1685-S	Switching, AM OSC Buffer
Q251	S 2SC1685-S	Switching, MW/LW OSC Controller
Q252 ~ 255	S 2SA722-S	Switching, MW/LW OSC Controller
Q256, 257	S 2SC1685-S	Switching, MW/LW OSC Controller
Q401	S 2SC1685-S	Indicators Drive
Q501 ~ 505	S 2SC1685-S	Muting Switching
Q506	S 2SA722-S	Muting Control (Product Part No. is 2SA564A)
Q701	2SD762-O	Regulator
Q702, 703	S 2SC1685-S	Regulator FM/AM Selector Control
Q704, 705	S 2SA722-S	FM/AM Selector Control (Product Part No. is 2SA564A)
Q901 ~ 903	S 2SC945-Q	Loop Filter
Q904 ~ 906	S 2SC1685-S	FM/MW/LM Maximum Scale Adj. and Counter Flow Prevention Loop Filter
Q908, 909	S 2SC1685-S	Loop Filter

Ref. No.	Part No.	Description
DIODES		
D101	MA	SV
D201	SV	SV
D251	MA	MA
D501 ~ 503	MA	MA
D701 ~ 705	Δ SVI	SVI
D706	SVI	SVI
D902, 903	MA	MA
D905 ~ 909	MA	MA
D911 ~ 916	MA	MA
D917	SVI	SVI
D918	SVI	SVI
D919	SVI	SVI
D920	MA	MA
D922, 923	MA	MA
COILS		
L202	S	S
L203	S	S
L251	S	S
L253	S	S
L254	S	S
TRANSFORMERS		
T101	SL	SL
T102	SL	SL
T201	SL	SL
T701	Δ SL	Δ SL
T701 [EK] only	Δ SL	Δ SL
CERAMIC FILTERS		
CF101, 102	SV	SV
CF201	SV	SV
CF201	SV	(Us anr
VARIABLE CAPAC		
CT201	SVI	SVI
CT251	SVI	SVI
VARIABLE RESIST		
VR301	S EV	EV
VR901	EV	EV
COMPONENT COM		
Z301, 302	EXI	EXI
Z901	EXI	EXI
Z902	EXI	EXI
CRYSTAL		
X901	SVI	SVI

Accessories

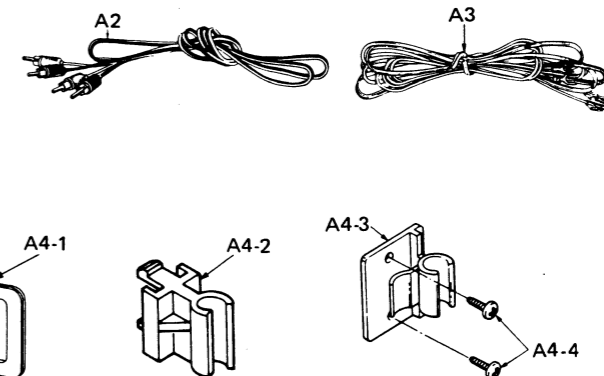

REPLACEMENT PARTS LIST

- Notes:**
- Part numbers are indicated on most mechanical parts. Please use this part number for parts order.
 - Important safety notice: Components identified by Δ mark have special characteristics important for safety. When replacing any of these components, use only manufacturer's specified parts.
 - \square -marked parts are used for black only, while \circ -marked parts are for silver type only.
 - Part other than \square and \circ -marked are used for both black and silver type.

- Bracketed indications in Ref. No. columns specify the area. Parts without these indications can be used for all areas.
- The "S" mark is service standard parts and may differ from production parts.
- The parenthesized numbers in the column of description stand for the quantity pre set.

Black type model No. : ST-5L (K)

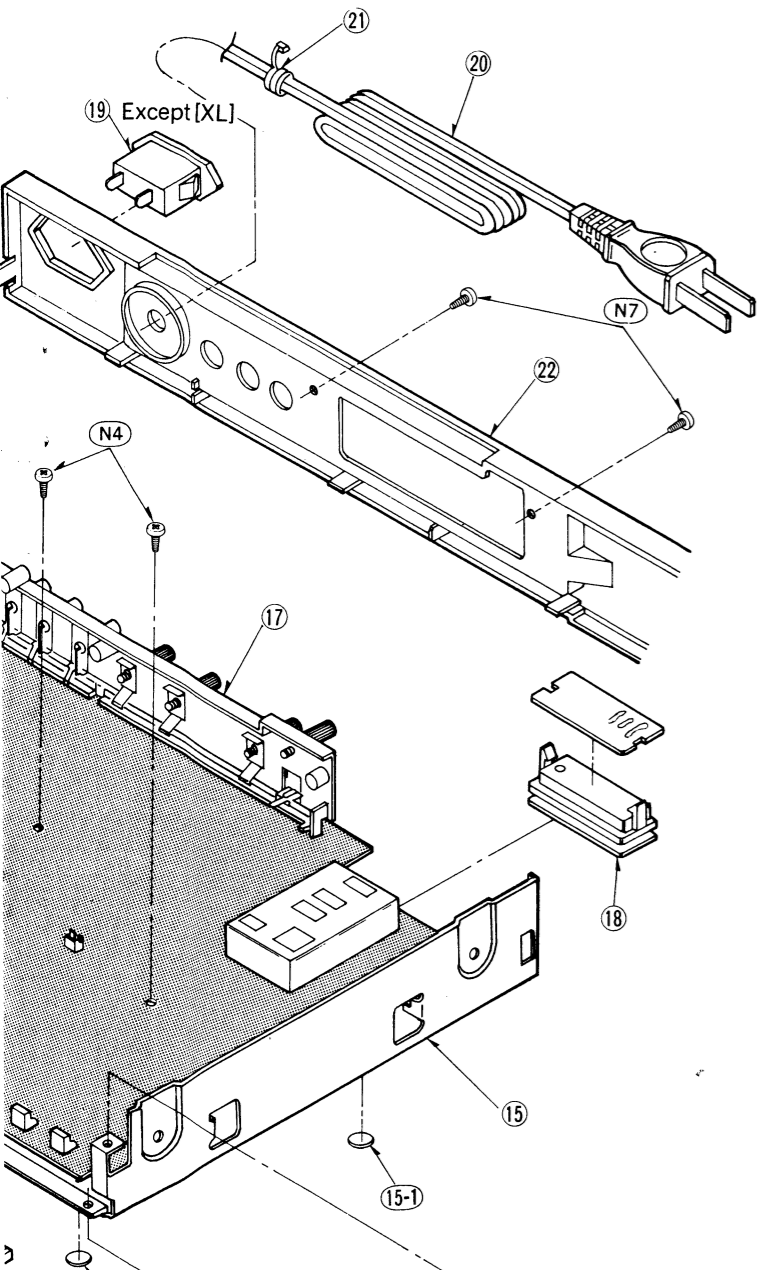

Ref. No.	Part No.	Description
INTEGRATED CIRCUITS		
IC101	AN278	FM IF Amplifier
IC102	AN7273	FM IF Amplifier
		FM/AM Detector
IC301	SVIUPC1161C3	FM MPX (Product Part No. is AN7470)
IC901	SVID1704C525	PLL Controller
IC902	SVIUPB553AC	Pre-Scaler
IC903	AN6873N	FL Driver
IC904	SVITC4013BP	FM Mode Select Controller
TRANSISTORS		
Q101, 201	S 2SC1685-S	Switching, AM OSC Buffer
Q251	S 2SC1685-S	Switching, MW/LW OSC Controller
Q252 ~ 255	S 2SA722-S	Switching, MW/LW OSC Controller
Q256, 257	S 2SC1685-S	Switching, MW/LW OSC Controller
Q401	S 2SC1685-S	Indicators Drive
Q501 ~ 505	S 2SC1685-S	Muting Switching
Q506	S 2SA722-S	Muting Control (Product Part No. is 2SA564A)
Q701	2SD762-O	Regulator
Q702, 703	S 2SC1685-S	Regulator FM/AM Selector Control
Q704, 705	S 2SA722-S	FM/AM Selector Control (Product Part No. is 2SA564A)
Q901 ~ 903	S 2SC945-Q	Loop Filter
Q904 ~ 906	S 2SC1685-S	FM/MW/LM Maximum Scale Adj. and Counter Flow Prevention Loop Filter
Q908, 909	S 2SC1685-S	Loop Filter

• Accessories

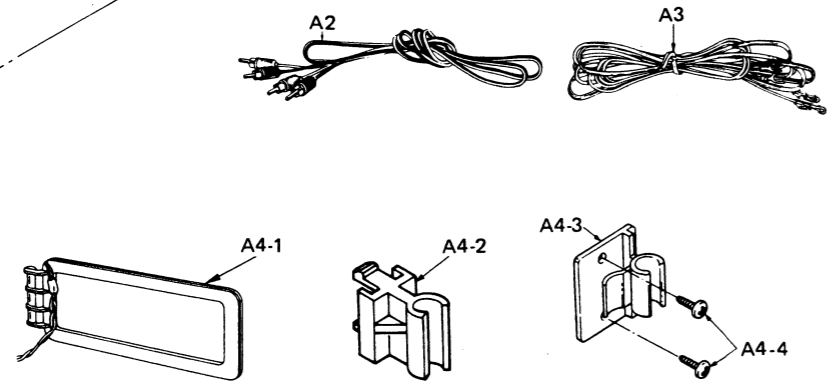

Ref. No.	Part No.	Description
DIODES		
D101	MA27W-A	Switching
D201	SVDKV1236Z	MW/LW Variable Capacitor
D251	MA162A	Switching
D501 ~ 503	MA162A	Switching
D701 ~ 705	Δ SVD5R1K2	Rectifier
D706	SVD5M306A	6V, Zener
D902, 903	MA162A	Switching
D905 ~ 909	MA162A	Switching
D911 ~ 916	MA162A	Switching
D917	SVD5M306A	6V, Zener
D918	SVD5M307A	7V, Zener
D919	SVD5M305A	5V, Zener
D920	MA162A	Switching
D922, 923	MA162A	Switching
COILS		
L202	SLA2C7-P	MW Antenna
L203	SLO2C31R-P	MW OSC
L251	SLA1C15R-P	LW Antenna Coil
L253	SLO1C17-P	LW OSC Coil
L254	SLQX101-3M	Choke Coil
TRANSFORMERS		
T101	SLI4C535-Z	FM IFT
T102	SLI4C537-Z	FM IFT
T201	SLI2C141-M	AM IFT
T701	Δ SLT5K135	Power Source
T701 [EK] only	Δ SLT5K137	Power Source
CERAMIC FILTERS		
CF101, 102	SVFE107MM-A	FM, 10.700 MHz (Red)
	SVFE107MM-B	FM, 10.675 MHz (Blue)
	SVFE107MM-C	FM, 10.725 MHz (Orange)
CF201	SVF5FP450HT	AM, 450 kHz (Use pair ranks as same as CF101 and CF102)
VARIABLE CAPACITORS		
CT201	SVCTZ03T110F	MW Antenna
CT251	SVCTZ03R200F	LW Antenna
VARIABLE RESISTORS		
VR301	S EVT33MA00B53	FM MPX VCO Adjustment 5k Ω
VR901	EVN58AA00B53	Analog Frequency Meter Adj.
COMPONENT COMBINATIONS		
Z301, 302	EXRP181K473C	180pF x 1 47k Ω x 1
Z901	EXBP87104K	100k Ω x 7
Z902	EXFP7331MW	331pF x 7
CRYSTAL		
X901	SVQ43U452	4.5 MHz Counter Oscillator

Ref. No.	Part No.	Description
FLUORESCENT DISPLAY TUBE		
FL	SAD7MT29ZA	
FUSE		
F1	Δ XBA2C05TR0	250V, T500mA
F2 [EX] only	Δ XBA2C16TR0	250V, T1.6A
SWITCHES		
S1	Δ SSH1069	Power Source
S3 ~ 6, 15, 16	SSG17	FM Mode, Memory Set, Tuning and FM/AM Selector
S7 ~ 14	SSG15	Pre Set Tuning
S19	SSS43	AM Allocation Selection
FRONT END		
	SNVFE306E05	P.C.B. Ass'y (Front End)
CABINET and CHASSIS PARTS		
1	\circ SGU289-2	Transparent Panel (Silver) (1)
1	\square SGU289-5	Transparent Panel (Black) (1)
2	\circ SKD4432	Tinted Plate (Silver) (1)
2	\square SKD4436	Tinted Plate (Black) (1)
3	\circ SGWT5LE	Panel, Front Ass'y (Silver) (1)
3	\square SGWT5LKE	Panel, Front Ass'y (Black) (1)
4	SDU89-1	Filter, FL (1)
5	SBC489	Button (1)
6	\circ SBC507	Button (Silver) (7)
6	\square SBC507-2	Button (Black) (7)
7	\circ SBC509	Button (Silver) (1)
7	\square SBC509-1	Button (Black) (1)
8	\circ SBC505-1	Button (Silver) (8)
8	\square SBC505-2	Button (Black) (8)
9	SUB111-1	Connection Rod, Power Switch (1)
10	SHG1545-1	Rubber FL (2)
11	SUS163	Spring (8)
12	SUS273	Spring (2)
13	SSM175-2	Meter (1)
14	LN03480P	L.E.D. (With Holder, Diode No. is LN417YPX3) (1)
15[EX]	SKUT5LE	Chassis Ass'y (W/Feet) (1)
15[EK]	SKUT5LK	Chassis Ass'y (W/Feet) (1)
15[EF,EB]	SKUT5LF	Chassis Ass'y (W/Feet) (1)
15-1	SKL245-2	Foot (4)
16	SHE129-1	Holder (1)
17	SJF8705-1N	Terminal Board (1)
17[EK] only	SJF8801N	Terminal Board (1)

Ref. No.	Part No.	Description
18	SJS9605	Socket, Direct Connector (1)
19	Δ SJS9225	Socket (1)
19[EK]	Δ SJS9227	Socket (1)
20	Δ SJA151	AC Cord (1)
20[EK]	Δ SJA149	AC Cord (1)
21	SHR127	Bushing, AC Cord (1)
22	SGP3211-2A	Panel, Rear (1)
22[EK]	SGP3211-3A	Panel, Rear (1)
23	\circ SKCT5N	Cabinet (Silver) (1)
23	\square SKCT5KE	Cabinet (Black) (1)
24	SJT347	Terminal, Fuse (4)
25	SHR301	Clamper (2)
SCREWS		
N1	S XTB3+8BFZ	Tapping, (3) x 8 (5)
N2	S XTB3+8BFN	Tapping, (3) x 8 (2)
N3	S XTB3+10BFN	Tapping, (3) x 10 (3)
N4	S XTBS3+8BFN	Tapping, (3) x 8 (3)
N5	S XTBS3+8BFZ	Tapping, (3) x 8 (1)
N6	S XTBS3+14BFN	Tapping, (3) x 14 (1)
N7	S XTBS3+8BFZ	Tapping, (3) x 8 (2)
N8	S SNE2095-2	Screw (4)
WASHERS		
N9	S XWC3	With Detent, ϕ 3 (2)
N10	S XWG3	Plain, ϕ 3 (2)
N11	S XWG3	Plain, ϕ 3 (1)
PACKING PARTS		
P1[EX, EB]	\circ SPG4057	Carton Box (Silver) (1)
P1[EX]	\square SPG4089	Carton Box (Black) (1)
P1[EK]	\circ SPG4059	Carton Box (Silver) (1)
P1[EK]	\square SPG4141	Carton Box (Black) (1)
P1[EF]	SPG4061	Carton Box (1)
P2	SPS3779-1	Pad, Front (1)
P2 [EK] only	SPS3781	Pad, Front (1)
P3	SPS3693-2	Pad, Left (1)
P3[EK] only	SPS3693-3	Pad, Left (1)
P4	SPS3695-2	Pad, Right (1)
P4[EK] only	SPS3695-3	Pad, Right (1)
P5	SPP691-1	Polyethylene Bag (1)
ACCESSORIES		
A1	SQF11397	Instructions Book (1)
A1[EK] only	SQF11399	Instructions Book (1)
A2	SJP2241-1	Cord Connection (1)
A3	SSA267	Cord, Indoor Antenna (1)
A4	SPB869-3	Loop Antenna Ass'y (1)
A4-1	SSA605-1	Loop Antenna (1)
A4-2	SMA235-1	Holder (1)
A4-3	SMA233-1	Holder (1)
A4-4	XTN3+10AFZ	Screw (2)