

Service Manual

Turtable System SL-D202

[E], [EK], [XL], [EG], [EB],
[EF], [XA], [XM], [EH], [Ei], [EC]

SL-D202(K)

[E], [EK], [XL], [EG], [EB],
[EF], [XA], [XM], [EH], [Ei], [EC]



* The colors of this model include silver and black.
* The black type model is provided with (K) in the Service Manual.

Areas

- * [E] is available in Switzerland and Scandinavia.
- * [EK] is available in United Kingdom.
- * [XL] is available in Australia.
- * [EG] is available in F.R. Germany.
- * [EB] is available in Belgium.
- * [EF] is available in France.
- * [XA] is available in Southeast Asia, Oceania, Africa, Middle Near East and Central South America.
- * [XM] is available in Central South America.
- * [EH] is available in Holland.
- * [Ei] is available in Italy.
- * [EC] is available in Czechoslovakia.

English

Specifications

Specifications are subject to change without notice for further improvement.
Weight and dimensions shown are approximate.

■ General

| | |
|-------------------------------|--|
| Power supply: | ~110-120/220-240 V, 50 or 60 Hz |
| Power consumption: | 7 W |
| Dimensions: (W×H×D) | 43 × 10.6 × 37.5 cm (16-15/16" × 4-7/32" × 14-3/4") |
| Weight: | 6 kg (13.2 lb.) |

Maximum height when top
(dust cover) is open.
43 × 37 × 42 cm
(16-15/16" × 14-9/16" × 16-17/32")

■ Turntable section

| | |
|------------------------------|---|
| Type: | Direct drive Automatic turntable Auto return, Auto stop |
| Drive method: | Direct drive |
| Motor: | Brushless DC motor |
| Drive control method: | F G servo control |
| Turntable platter: | Aluminum die-cast Diameter 31.2 cm (12-9/32 inches) |
| Turntable speeds: | 33-1/3 rpm and 45 rpm |
| Pitch control: | 10% adjustment range |
| Wow and flutter: | 0.012% WRMS* 0.025% WRMS (JIS C5521) ±0.035% peak (IEC 98A Weighted) |

*This rating refers to turntable assembly alone, excluding effects of record, cartridge or tonearm, but including platter. Measured by obtaining signal from built-in frequency generator of motor assembly.

| | |
|----------------|--|
| Rumble: | -56 dB (IEC 98A Unweighted) -78 dB (IEC 98A Weighted) |
|----------------|--|

■ Tonearm section

| | |
|---|--|
| Type: | Universal tonearm "S" shaped tubular arm Static balanced type |
| Effective length: | 230 mm (9-1/16") |
| Overhang: | 15 mm (19/32") |
| Tracking error angle: | Within 2°32' at the outer groove of 30 cm (12") record Within 0°32' at the inner groove of 30 cm (12") record |
| Offset angle: | 22° |
| Friction: | Less than 7 mg (lateral, vertical) |
| Effective mass: | 11 g (without cartridge) |
| Applicable cartridge weight range: | See page 8. |
| Stylus pressure adjustment range: | 0—2.5 g |
| Headshell weight: | 7.5 g |
| Phono cable capacitance: | 135 pF |

Technics

Matsushita Electric Trading Co., Ltd.
P.O. Box 288, Central Osaka Japan

■ Cartridge section

| | |
|----------------------------|---|
| Type: | Moving magnet |
| Frequency response: | 10 Hz~35 kHz 20 Hz~10 kHz ± 1 dB |
| Output voltage: | 2.5 mV at 1 kHz 5 cm/s. zero to peak lateral velocity (7 mV at 1 kHz 10 cm/s. zero to peak 45° velocity [DIN 45 500]) |

| | |
|------------------------------|--|
| Channel separation: | 22 dB at 1 kHz |
| Channel balance: | Within 1.8 dB at 1 kHz |
| Compliance (dynamic): | 10×10^{-6} cm/dyne at 100 Hz |
| Stylus pressure: | 1.75 \pm 0.25 g (17.5 \pm 2.5 mN) |
| Load impedance: | 47 k Ω to 100 k Ω |
| Weight: | 5 g (cartridge only) |
| Replacement stylus: | EPS-25CS Equivalent replacement stylus EPS-25ES (Elliptical stylus). |

Deutsch

TECHNISCHE DATEN

Änderungen der technischen Daten vorbehalten.
Die angegebenen Gewichts- und Abmessungsdaten sind circa Werte.

■ Allgemeine Daten

| | |
|---------------------------------|---|
| Stromversorgung: | ~110-120/220-240 V, 50/60 Hz Wechselstrom |
| Leistungsaufnahme: | 7 W |
| Abmessungen (B×H×T): | 43 × 10,6 × 37,5 cm 43 × 37 × 42 cm Maximale Höhe bei geöffnetem Gehäuseoberteil |
| Gewicht: | 6 kg |

■ Plattenspieler

| | |
|---|---|
| Typ: | Direktantrieb Automatischer Plattenspieler Rückführautomatik Stopautomatik |
| Antrieb: | Direktantrieb |
| Motor: | Kollektorloser Gleichstrommotor |
| Antriebsregel-Methode: | FG-Servo-Steuerung |
| Plattenteller: | Aluminium-Spritzguß Durchmesser 31,2 cm |
| Plattenteller- Drehzahlen: | 33-1/3 und 45 U/min |
| Drehzahl- Feinregulierung: | 10% Einstellbereich |
| Gleichlaufschwankungen: | 0,012% WRMS* 0,025% WRMS (JIS C5521) $\pm 0,035\%$ Spitze (IEC 98A bewertet) |
| Rumpel-Geräusch- spannungsabstand: | -56 dB (IEC 98A unbewertet) |
| Rumpel-Fremd- spannungsabstand: | -78 dB (IEC 98A bewertet) |

* Diese Nennleistung bezieht sich auf das Laufwerk-Bauteil allein, ausschließlich Einflüsse von Schallplatte, Tonabnehmer oder Tonarm, aber einschließlich Plattenteller. Gemessen anhand von Signalen vom eingebauten Frequenzgenerator des Motorbauteils.

■ Tonarm

| | |
|---|--|
| Typ: | Universal-Tonarm S-förmiger Rohrtonarm Statisch ausbalanciert |
| Effektive Länge: | 230 mm |
| Überhang: | 15 mm |
| Spurfehlwinkel: | 2° 32' bei der Einlaufrille einer 30 cm-Platte 0° 32' bei der Auslaufrille einer 30 cm-Platte |
| Kröpfungswinkel: | 22° |
| Lagerreibung: | Weniger als 7 mg (horizontal, vertikal) |
| Effektive Masse: | 11 g (ohne Tonabnehmer) |
| Zulässiger Ton- abnehmer- Gewichtsbereich: | (Seite 8) |
| Auflagekraft- Einstellbereich: | 0—2,5 g |
| Tonarmkopf-Gewicht: | 7,5 g |
| Phonokabel- Kapazität: | 135 pF |

■ Tonabnehmer

| | |
|--|---|
| Typ: | Magnetischer Tonabnehmer |
| Frequenzgang: | 10 Hz bis 35 kHz 20 Hz bis 10 kHz ± 1 dB |
| Ausgangsspannung: | 2,5 mV bei 1 kHz 5 cm/s. Null-zu-Spitze, lateral [7 mV bei 1 kHz 10 cm/s. Null- zu-Spitze, 45° (DIN 45 500)] |
| Kanaltrennung: | 22 dB bei 1 kHz |
| Kanalabweichung: | Innerhalb 1,8 dB bei 1 kHz |
| Nachgiebigkeit (dynamisch): | 10×10^{-6} cm/dyn bei 100 Hz |
| Auflagekraft: | 1,75 \pm 0,25 g (12,5 \pm 17,5 mN) |
| Impedanz: | 47 k Ω bis 100 k Ω |
| Gewicht: | 5 g (ohne Tonarmkopf) |
| Ersatznadel: | EPS-25CS Gleichwertige Ersatznadel: EPS-25ES |

CARACTERISTIQUES

Les spécifications sont susceptibles d'être modifiées sans préavis.
Le poids et les dimensions donnés sont approximatifs.

■ Généralités

| | |
|-----------------------------------|--|
| Alimentation: | Alternatif 110-120/220-240V, 50 ou 60 Hz |
| Consommation: | 7 W |
| Dimensions: (L × H × P) | 43 × 10,6 × 37,5 cm 43 × 37 × 42 cm (Hauteur maximum lorsque le dessus (couvercle protège- poussière) est ouvert.) |
| Poids: | 6 kg |

■ Platine de lecture

| | |
|---|---|
| Type: | Entraînement direct Platine automatique Retour automatique Arrêt automatique |
| Système d'entraîne- ment: | Entraînement direct |
| Moteur: | Moteur C.C. sans balai |
| Groupe de réglage: | Servocommande du générateur de fréquences |
| Plateau de lecture: | En aluminium moulé sous pression Diamètre 31,2 cm |
| Vitesses de rotation: | 33-1/3 et 45 t/p.m |
| Réglage d'écart: | Plage de réglage de 10% |
| Pleurage et scintille- ment: | 0,012% de valeur efficace* 0,025% de valeur efficace (JIS C5521) ±0,035% de crête (IEC 98A Pondéré) |

* Ce régime nominal se rapporte à l'ensemble du tourne-
disque seul, excluant les effets du disque, de la cellule
pick-up ou du bras de lecture, mais comprenant le plateau.
Mesuré par l'obtention d'un signal provenant du géné-
rateur de fréquences incorporé de l'ensemble du moteur.

| | |
|--------------------|--|
| Ronflement: | -56 dB (IEC 98A Non pondéré) -78 dB (IEC 98A Pondéré) |
|--------------------|--|

■ Bras de lecture

| | |
|---|--|
| Type: | Bras de lecture universel Bras tubulaire en forme de "S" De type à équilibrage statique 230 mm |
| Longueur effective: | 230 mm |
| Porte-à-faux: | 15 mm |
| Angle d'erreur de piste: | En deçà de 2° 32' au sillon extérieur d'un disque de 30 cm En deçà de 0° 32' au sillon intérieur d'un disque de 30 cm |
| Angle de décalage: | 22° |
| Frottement: | Moins de 7 mg (latéral et vertical) |
| Masse réelle: | 11 g (sans la cellule pick-up) |
| Gamme du poids des cellules pick-up utilisables: | (page 8) |
| Plage de réglage de la pression d'appui: | 0—2,5 g |
| Poids de la coque porte-cellule: | 7,5 g |
| Capacitance propre du câble pick-up: | 135 pF |

■ Cellule pick-up

| | |
|---|--|
| Type: | Aimant mobile |
| Réponse en fréquence: | 10 Hz à 35 kHz 20 Hz à 10 kHz ±1 dB |
| Tension de sortie: | 2,5 mV à 1kHz; 5 cm/s., zéro à vitesse latérale de crête (7 mV à 1 kHz 10 cm/s., zéro à vitesse 45° de crête [DIN 45 500]) |
| Séparation de canal: | 22 dB à 1 kHz |
| Équilibrage des canaux: | En deçà de 1,8 dB à 1 kHz |
| Elasticité (dynamique): | 10×10 ⁻⁶ cm/dyne à 100 Hz |
| Pression de la pointe de lecture: | 1,75±0,25 g (17,5±2,5 mN) |
| Impédance de charge: | 47 kΩ to 100 kΩ |
| Poids: | 5 g (cellule seule) |
| Pointe de lecture de remplacement: | EPS-25CS (Pointe de lecture de remplacement équivalente: EPS-25ES) |

ESPECIFICACIONES

Las especificaciones quedan sujetas a cambios sin aviso previo.
El peso y las dimensiones indicados son aproximados.

■ En general

| | |
|---|--|
| Alimentación de corriente: | ~110—120/220—240 V, 50 ó 60 Hz |
| Consumo de corriente: | 7 W |
| Dimensiones: (Ancho × Alto × Prof.) | 43 × 10,6 × 37,5 cm 43 × 37 × 42 cm (Altura máxima cuando la parte de arriba (tapa contra el polvo) está abierta.) |
| Peso: | 6 kg |

■ Sección del plato giratorio

| | |
|--|--|
| Tipo: | Accionamiento directo Plato giratorio automático Retorno automático Parada automática |
| Método de acciona- miento: | Accionamiento directo |
| Motor: | Motor de corriente continua sin escobillas |
| Método de control de accionamiento: | Servocontrol por generador de frecuencias |

| | |
|---|--|
| Platillo del plato giratorio: | Aluminio fundido |
| | Diámetro 31,2 cm |
| Velocidades del plato giratorio: | 33-1/3 y 45 rpm |
| Control de altura de sonido: | 10% |
| Ululaciones y trémolo: | 0,012% WRMS* 0,025% WRMS (JIS C5521) ±0,035% cresta (IEC 98A Ponderado) |

* Estas características se refieren únicamente al conjunto del plato giratorio, con exclusión de los efectos provenientes del disco, cartucho o del brazo sonoro, incluyendo, empero, el platillo. La medida fue tomada por medio de la señal obtenida del generador de frecuencia incorporado del conjunto del motor.

Ruido de rodadura: -56 dB (IEC 98A No ponderado)
-78 dB (IEC 98A Ponderado)

■ Sección del brazo sonoro

| | |
|--|--|
| Tipo: | Brazo sonoro universal Brazo tubular en forma de "S" Tipo equilibrado estático |
| Longitud efectiva: | 230 mm |
| Proyección: | 15 mm |
| Angulo de error de seguimiento: | Inferior a 2°32' en el surco exterior de un disco de 30 cm Inferior a 0°32' en el surco interior de un disco de 30 cm |

| | |
|---|--|
| Angulo de descentramiento: | 22° |
| Fricción: | Menos de 7 mg (en sentido lateral y vertical) |
| Masa efectiva: | 11 g (sin cartucho) |
| Radio de peso de cartucho utilizable: | (página 8) |
| Radio de ajuste de la presión de la aguja: | 0 a 2,5 g |
| Peso de la cápsula de la cabeza: | 7,5 g |
| Capacitancia de cable de fono: | 135 pF |

■ Sección del cartucho

| | |
|---------------------------------|--|
| Tipo: | Imán móvil |
| Respuesta de frecuencia: | de 10 Hz a 35 kHz de 20 Hz a 10 kHz ±1 dB |
| Voltaje de salida: | 2,5 mV a 1 kHz Con velocidad lateral de cero a cresta de 5 cm/s [7 mV a 1 kHz Velocidad de 45° de cero a cresta de 10 cm/s (DIN 45 500)] |
| Separación de canales: | 22 dB a 1 kHz |
| Equilibrio de canales: | Sin exceder 1,8 dB a 1 kHz |
| Elasticidad (dinámica): | 10×10 ⁻⁶ cm/dina a 100 Hz |
| Presión de la aguja: | 1,75 ±0,25 g (17,5 ±2,5 mN) |
| Impedancia de carga: | 47 kΩ a 100 kΩ |
| Peso: | 5 g (cartucho sólo) |
| Aguja de recambio: | EPS-25CS (Aguja de recambio equivalente: EPS-25ES) |

■ CONTENTS

| | |
|--|-------------|
| | Page |
| LOCATION OF CONTROLS | 5 |
| DISASSEMBLY INSTRUCTIONS | 6, 7 |
| REPLACEMENT OF HALL ELEMENT | 8 |
| CARTRIDGE INSTALLATION | 8 |
| ABOUT CARTRIDGE WEIGHT | 8 |
| MEASUREMENTS AND ADJUSTMENTS (English) | 9, 10 |
| MESSUNGEN UND JUSTIERUNGEN (Deutsch) | 10, 11 |
| MESURAGES ET RÉGLAGES (Français) | 11, 12 |
| MEDICIONES Y AJUSTES (Español) | 12, 13 |

| | |
|--|-------------|
| | Page |
| BLOCK DIAGRAM | 14 |
| CIRCUIT BOARD AND WIRING | |
| CONNECTION DIAGRAM | 15, 16 |
| SCHEMATIC DIAGRAM | 17, 18 |
| EXPLODED VIEWS | 19, 20, 22 |
| REPLACEMENT PARTS LIST | |
| Cabinet, Chassis and Packing Parts | 21, 22 |
| Electrical Parts | 23 |
| PACKINGS | 24 |

■ LOCATION OF CONTROLS

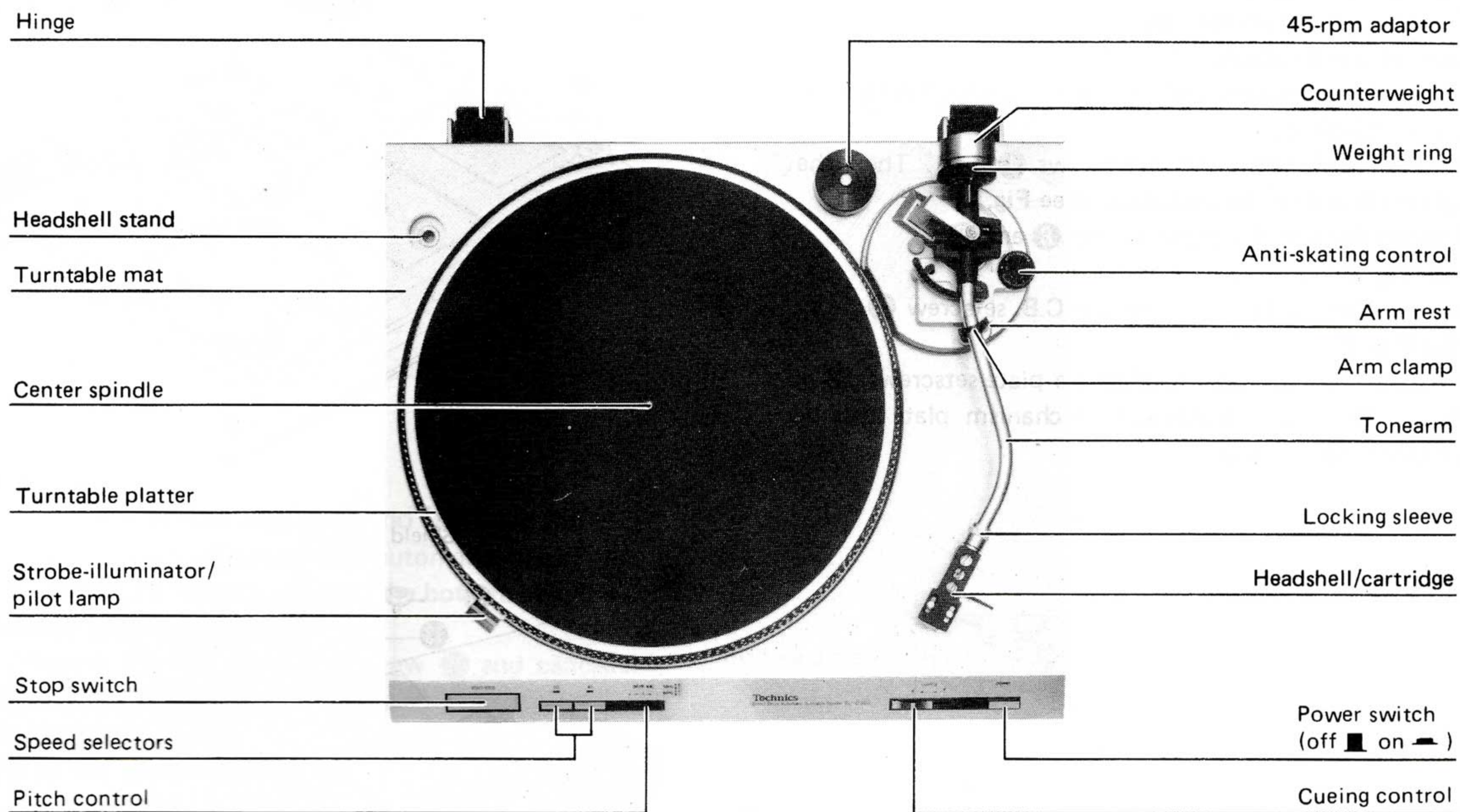

Pitch control VR (VR201)

Stop/speed selector P.C.B. **C**

Strobe lamp P.C.B.

Drive circuit P.C.B. **A**

Stator frame **D**

Power transformer (T1)

Power source P.C.B. **B**

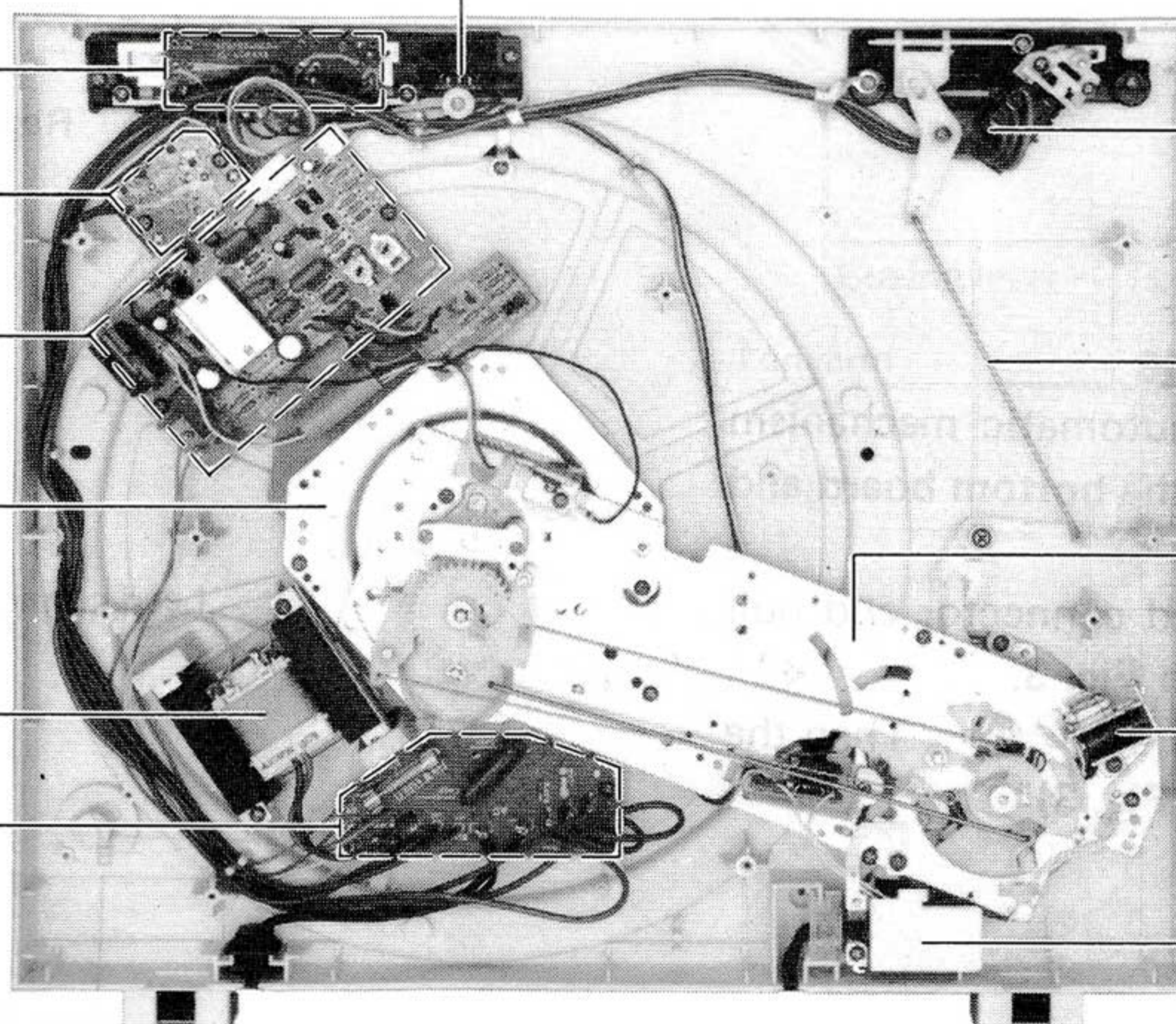

Power switch (S2)

Cueing rod

Automatic mechanism plate

Stop plunger (RL1)

Shield plate

■ DISASSEMBLY INSTRUCTIONS

● How to remove the bottom board and automatic mechanism plate

1. Fix the tonearm on the rest.
2. Remove the turntable.
3. Close the dust cover, and turn over the unit, taking care not to scratch it.
4. Remove the bottom board setscrews ① ~ ⑦. Then, the bottom board can be removed. (See Fig. 1)
5. Remove the shield plate setscrews ⑧ and ⑨. (See Fig. 2)
6. Remove the regulator transistor P.C.B. setscrew ⑩. (See Fig. 2)
7. Remove the automatic mechanism plate setscrews ⑪ ~ ⑯. Then, the automatic mechanism plate can be removed. (See Fig. 2)

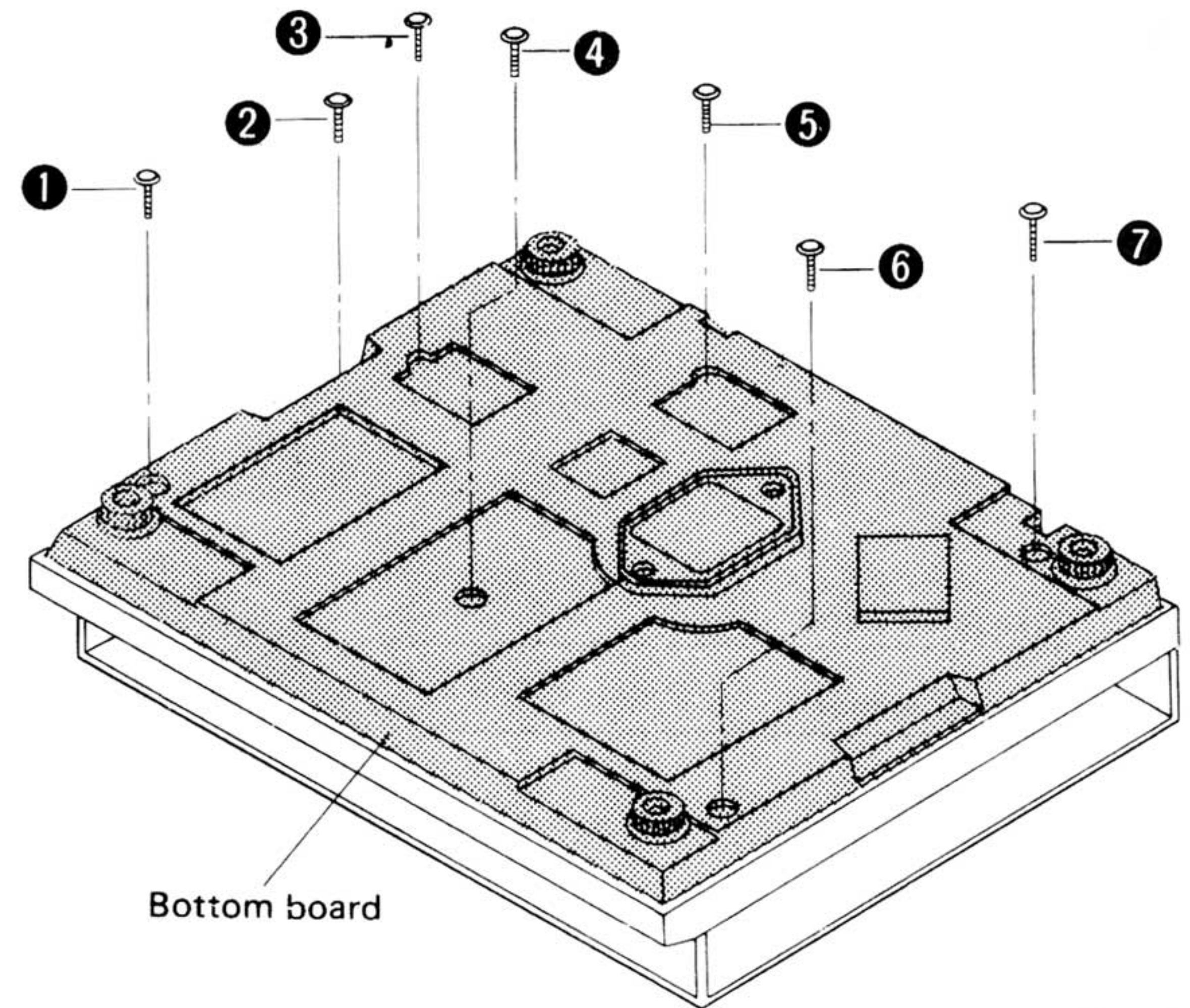

Fig. 1

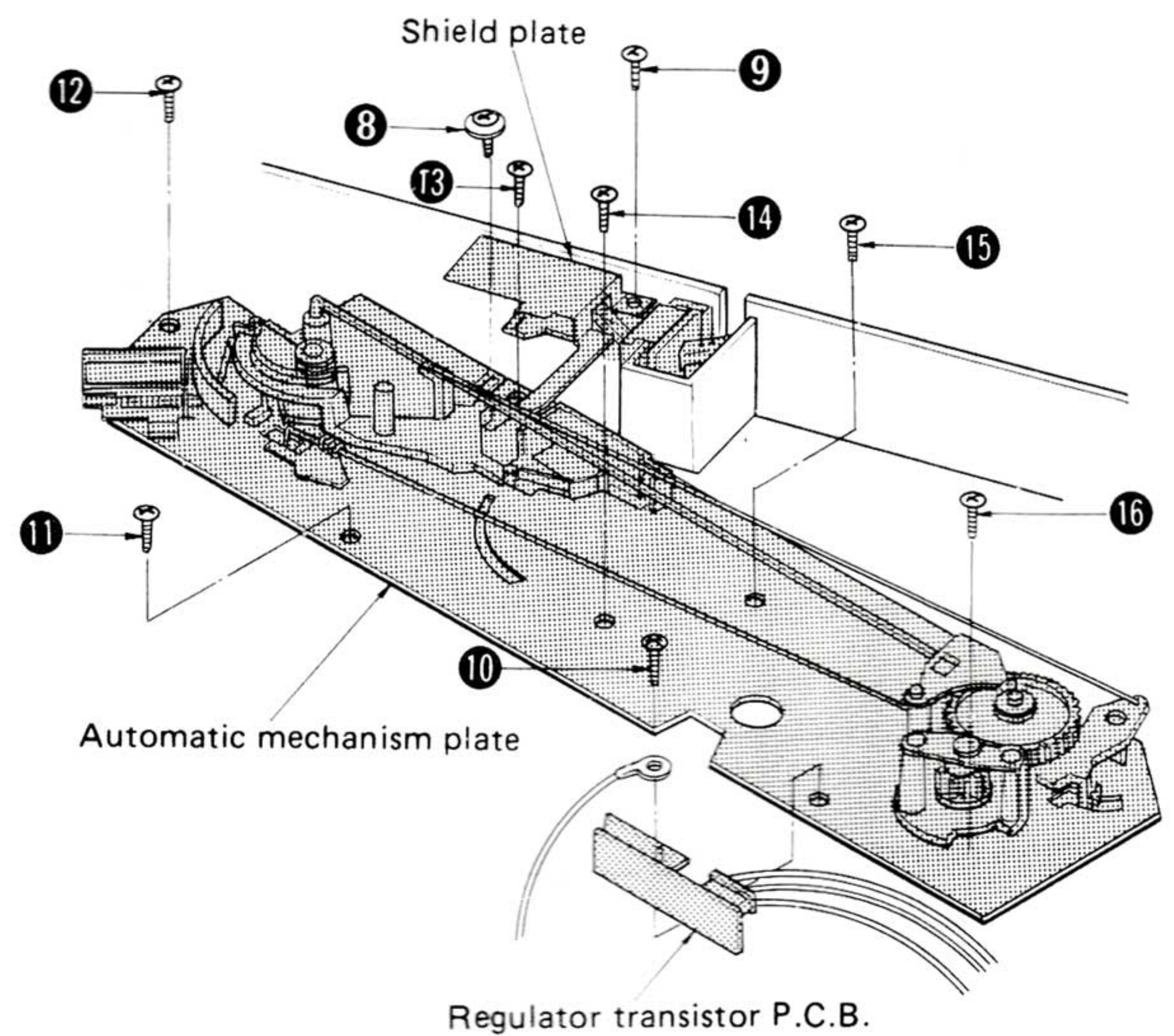

Fig. 2

● How to remove the stator frame

1. Remove the bottom board and automatic mechanism plate. (Refer to "How to remove the bottom board and automatic mechanism plate".)
2. Open the "lead holder" of the lead connector and pull out the lead wire of the arrow (A) in Fig. 3.
3. Remove the stator frame setscrews ⑰ ~ ⑲. Then the stator frame can be removed. (See Fig. 3)

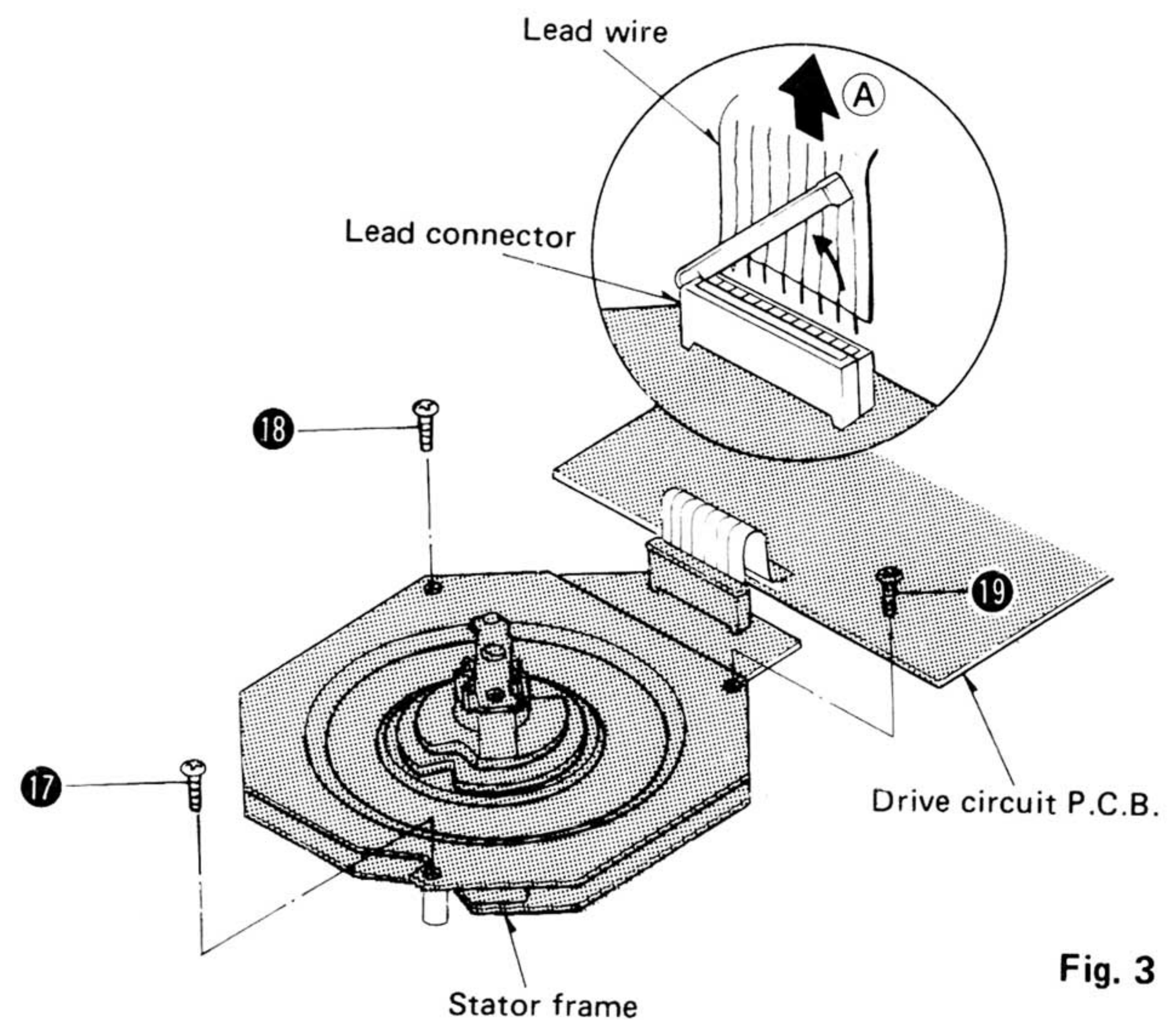

Fig. 3

● **How to remove the drive circuit P.C.B.**

1. Remove the bottom board. (Refer to "How to remove the bottom board and automatic mechanism plate".)
2. Open the "lead holder" of the lead connector and pull out the lead wire. (Refer to "How to remove the stator frame".)
3. Remove the drive circuit P.C.B. setscrews ⑳ ~ ㉒ and connectors ㉓ and ㉔. Then the drive circuit P.C.B. can be removed. (See Fig. 4)

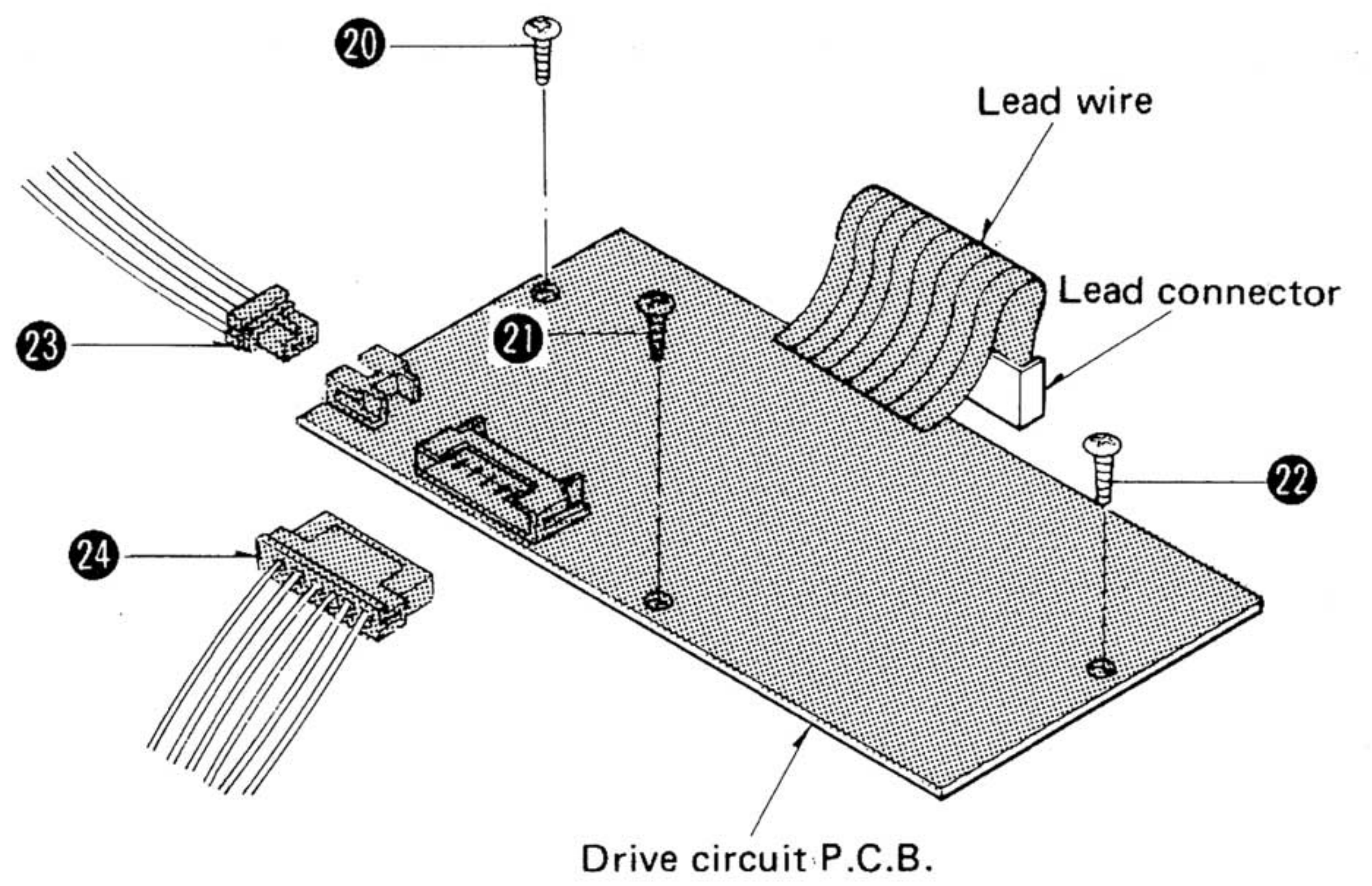

Fig. 4

● **How to remove the tonearm and lift base plate**

1. Remove the bottom board and automatic mechanism plate. (Refer to "How to remove the bottom board and automatic mechanism plate".)
 2. Remove the PU fixing plate setscrew ㉕ and canceller spring. (See Fig. 5)
 3. Unsolder the 5 lead wires from the tonearm. (See Fig. 5)
 4. Remove the tonearm setscrews ㉖ and ㉗. Then the tonearm can be removed. (See Fig. 5)
 5. To disassemble the lift substrate, disengage the arm lift fixing screw ㉘ before turning over the body, then remove the arm lift. (See Fig. 6)
- Note:** Remove the spring under the arm lift at the same time.
6. Remove the anti-skating control knob. (See Fig. 6)
 7. Turn over the unit and remove the PU fixing plate.
 8. Remove the lift base plate setscrews ㉙ and ㉚. Then, the lift base plate can be removed. (See Fig. 5)

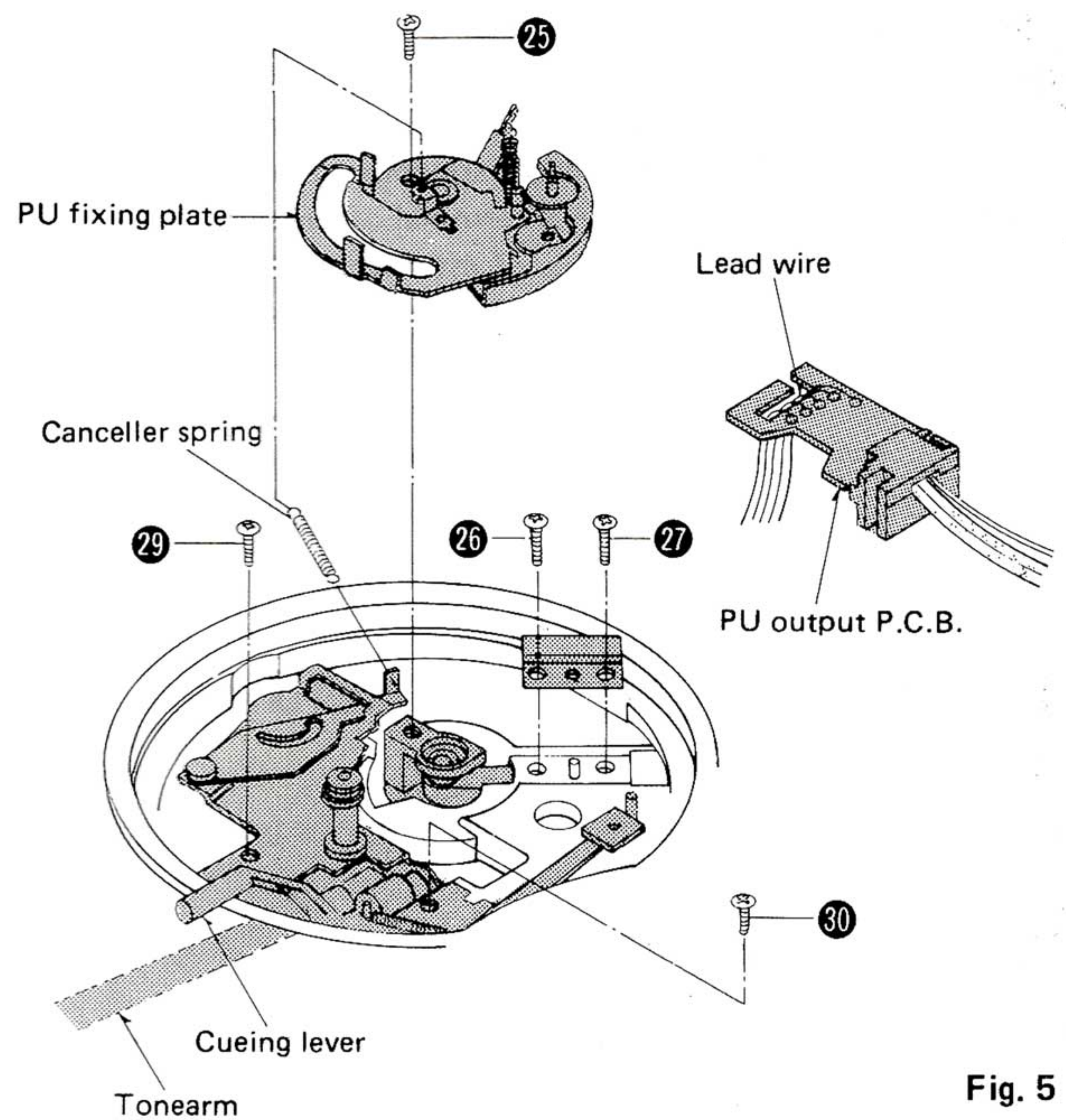

Fig. 5

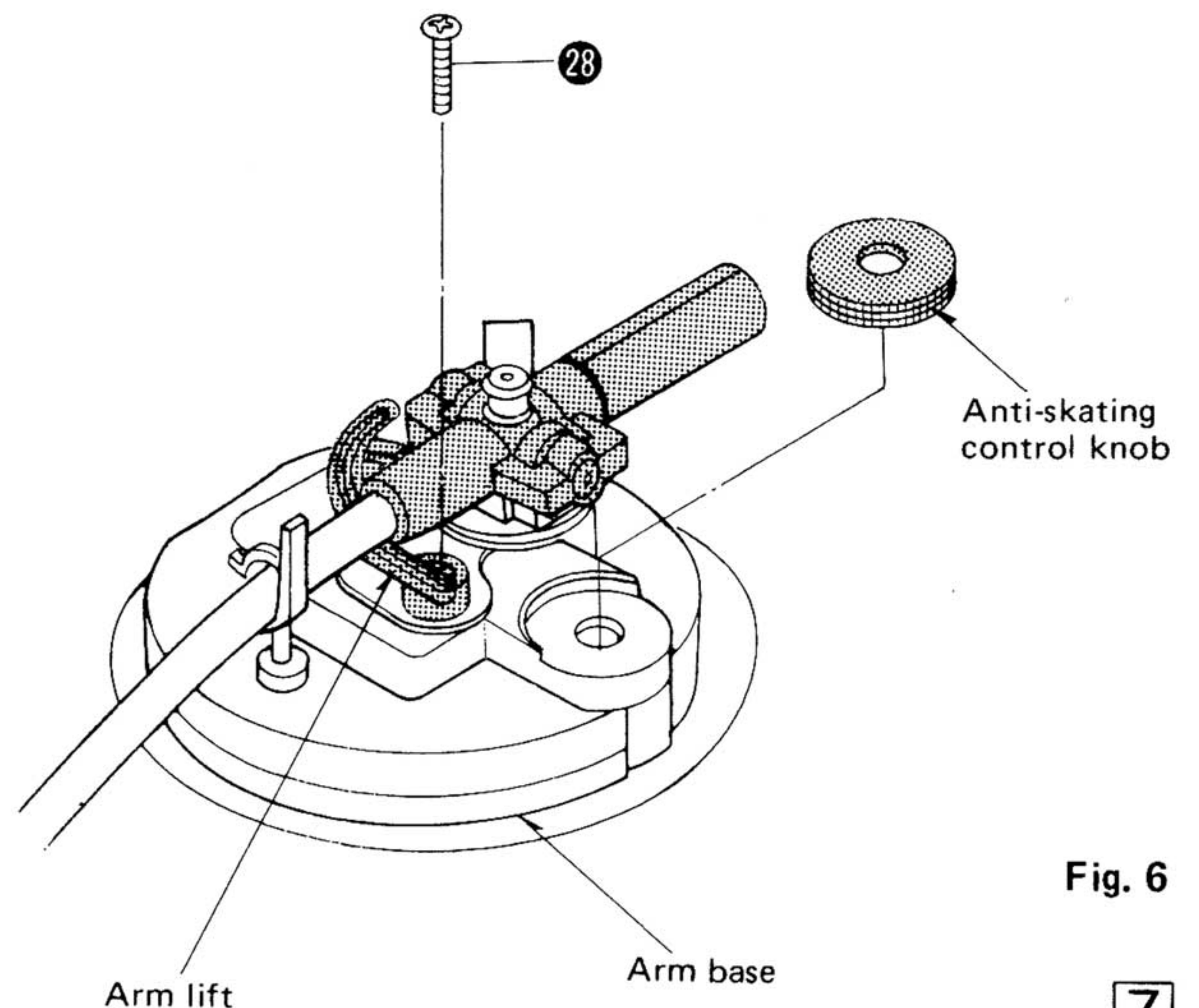

Fig. 6

REPLACEMENT OF HALL ELEMENT

When replacing the Hall element of the stator frame, be sure to place it with the marking side up as shown Fig. 7.

※ The leg position is not specified provided that the marking side is up.

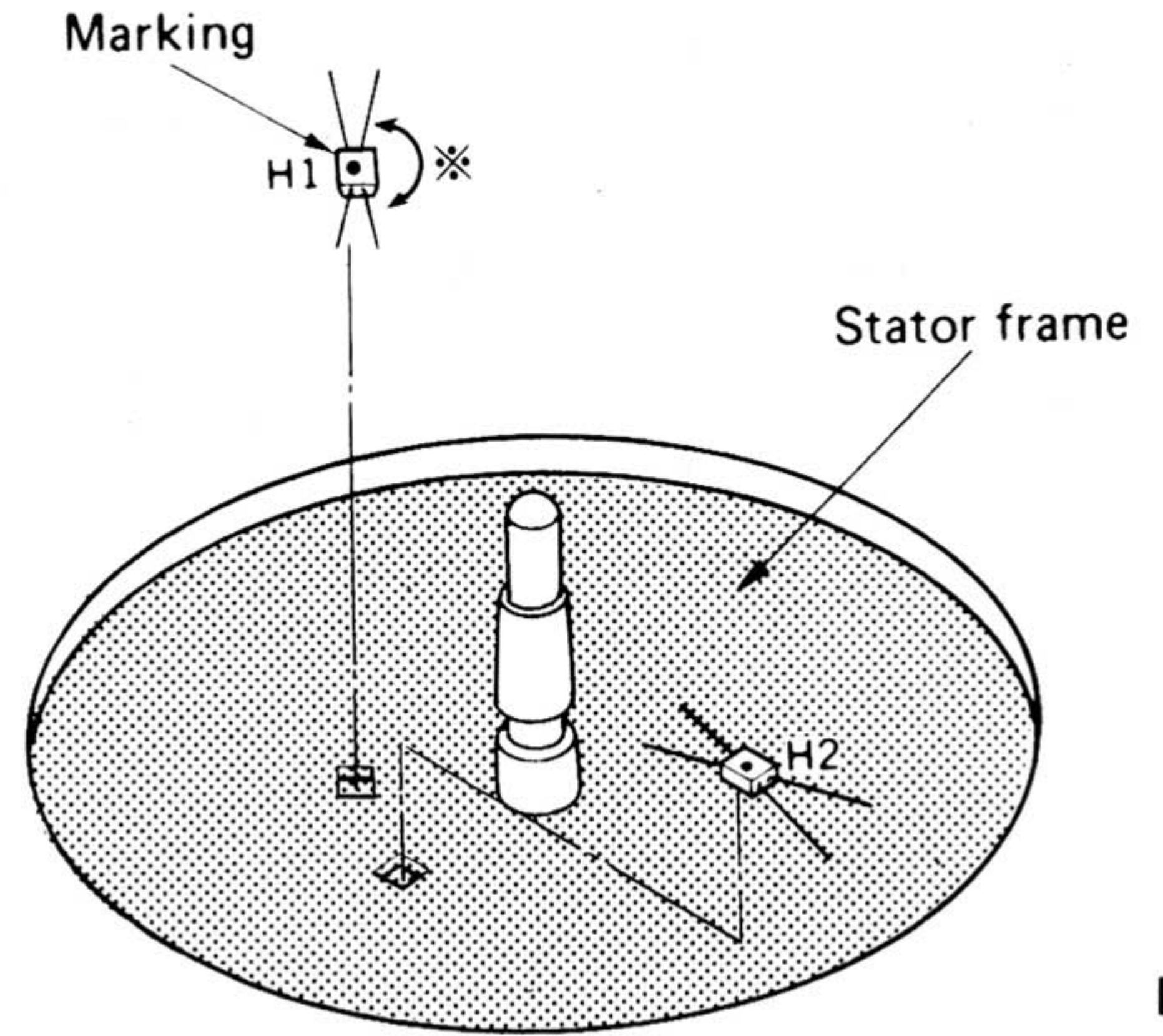

Fig. 7

CARTRIDGE INSTALLATION

When installing a cartridge, follow the instructions that came with the cartridge.

1. Connect the lead wires to the cartridge terminals.
The terminals of most cartridges are color coded.
Connect each lead wire to the terminal of the same color.

| | |
|------------|-----------------|
| White (L+) | Left channel + |
| Blue (L-) | Left channel - |
| Red (R+) | Right channel + |
| Green (R-) | Right channel - |
2. Mount the cartridge in the headshell using the screws provided with the cartridge. (Fig. 8)

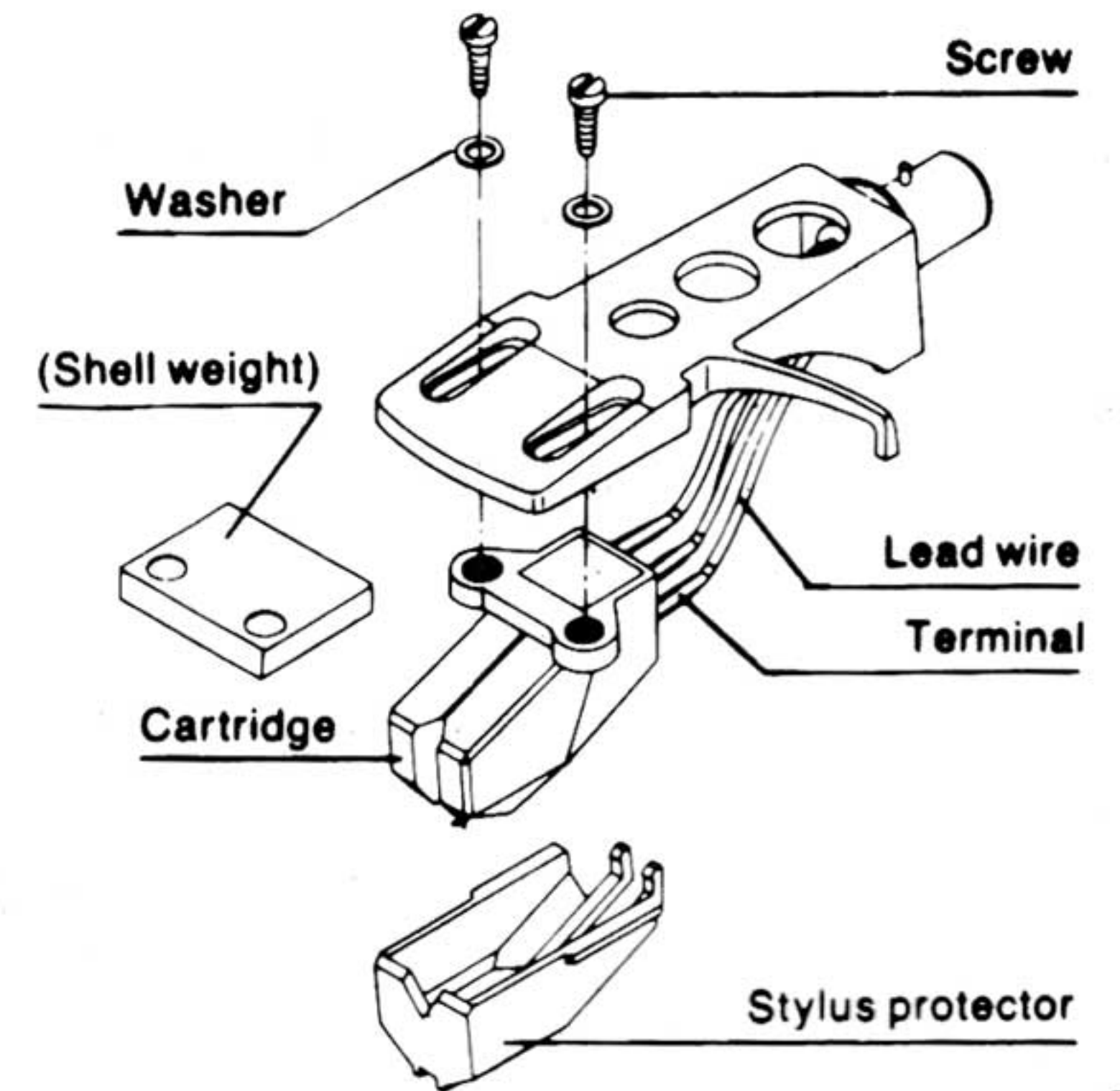





Fig. 8

ABOUT CARTRIDGE WEIGHT

(See chart below)

Cartridges weighing between 3.5 and 7.5 g can be used on this tonearm (with the headshell and accessory shell weight supplied).

| Supplied headshell in combination with other parts. | Allowable cartridge weight. (Included the cartridge mounting screws) | |
|--|---|-----------------|
| | 4 g | 5 6 7 8 9 10 11 |
| A)  Headshell only (7.5 g) | 5 g — 7.5 g | |
| B)  +  Shell weight | 3.5 g — 5 g | |

● Arm-lift height adjustment

The arm-lift height (distance between the stylus tip and record surface when the cueing control is set to the "▼" position) has been adjusted at the factory to approximately 5 mm (3/16"). (Fig. 9)

If the clearance is too narrow or too wide (because of different cartridge dimensions, for example), turn the adjustment screw clockwise or counterclockwise.

(See Fig. 10)

Clockwise rotation

—distance between the record and stylus tip is decreased.

Counterclockwise rotation

—distance between the record and stylus tip is increased.

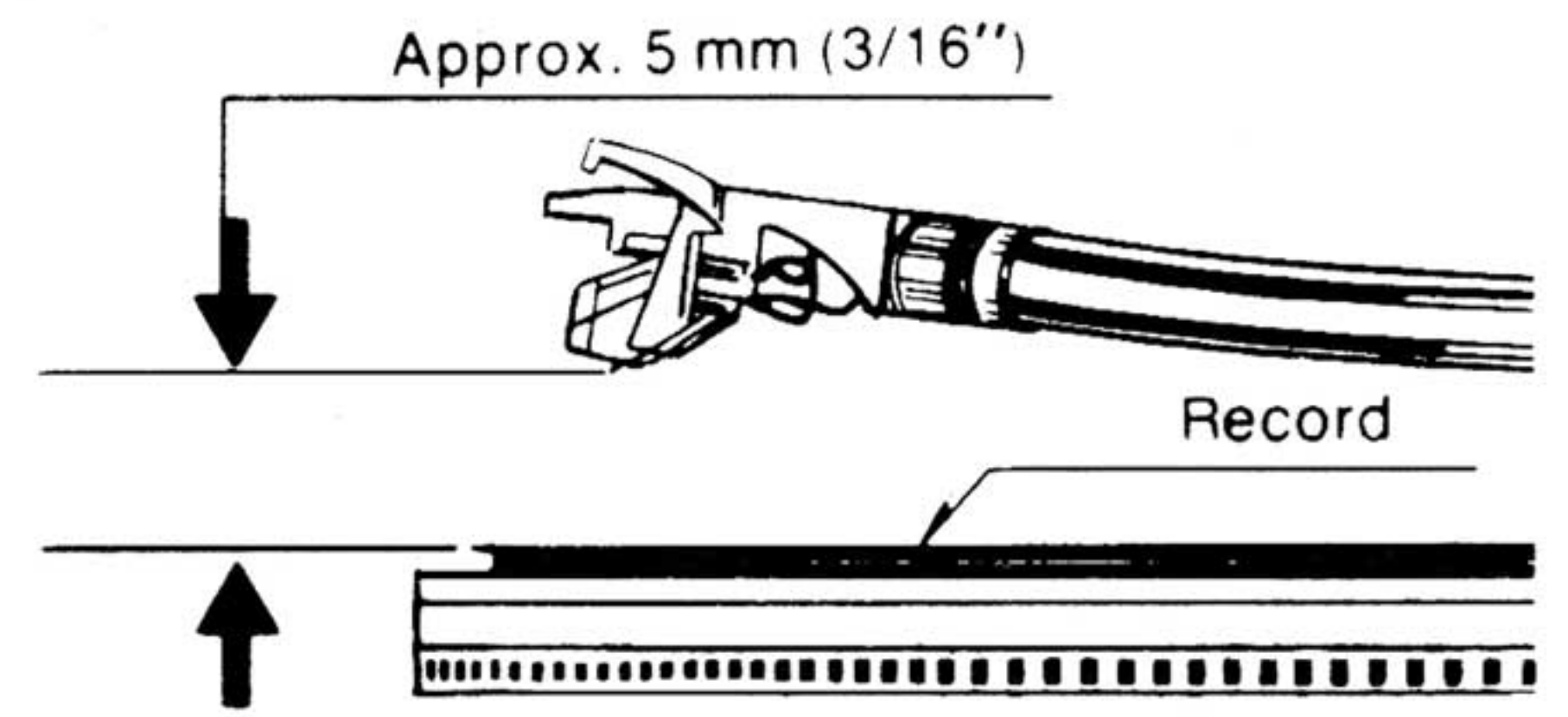

Fig. 9
(Abb. 9)

● Adjustment of automatic return position (Fig. 11)

1. Put the stylus protector on the cartridge.
2. Take off the rubber cap covering the adjustment screw section and move the tonearm toward the center of the record.

Then, the auto-return position adjustment screw will appear.

If the tonearm tends to return to the arm rest before the play has finished,

—turn counterclockwise.

If the tonearm fails to return after the final groove,

—turn clockwise.

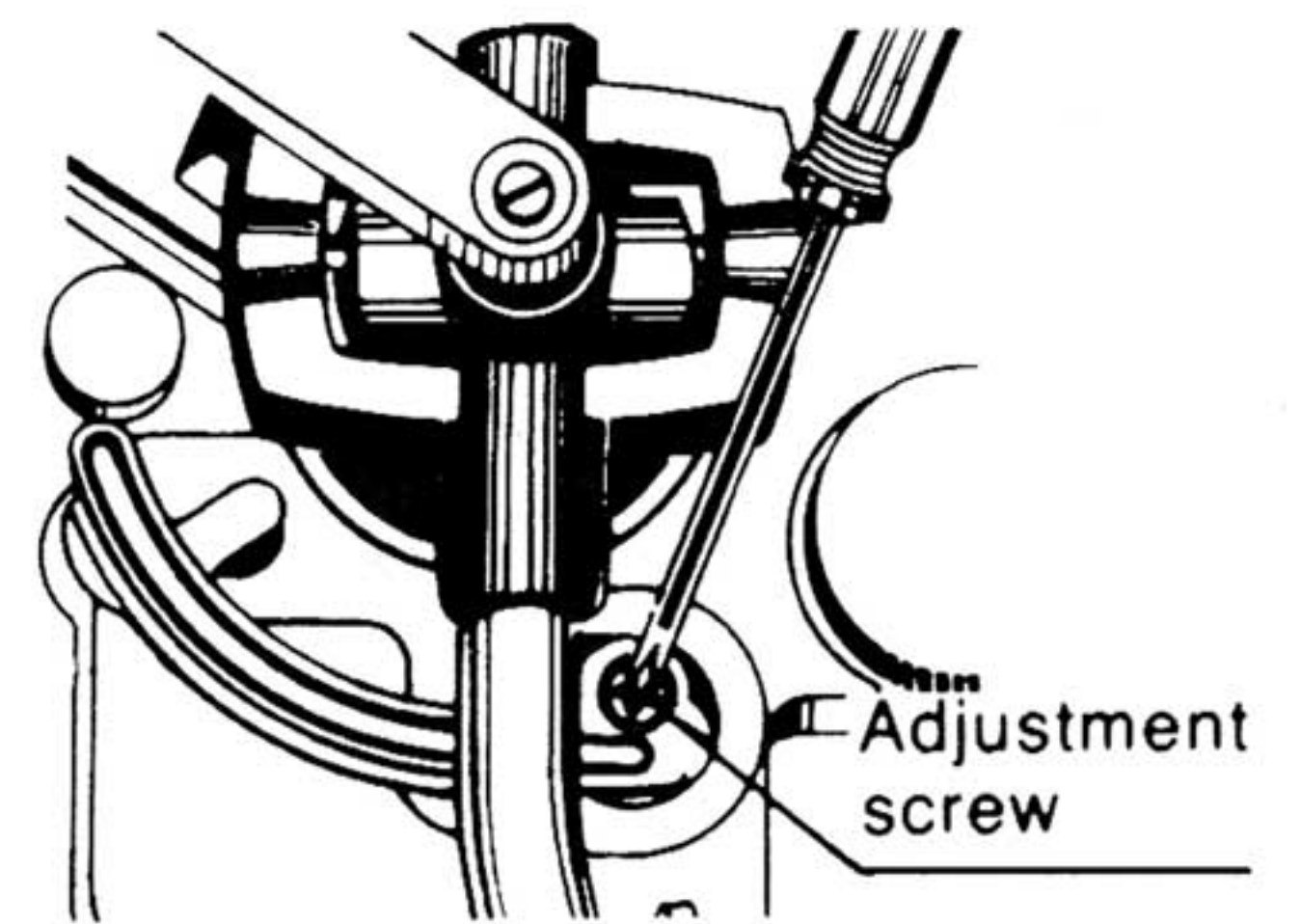

Fig. 10
(Abb. 10)

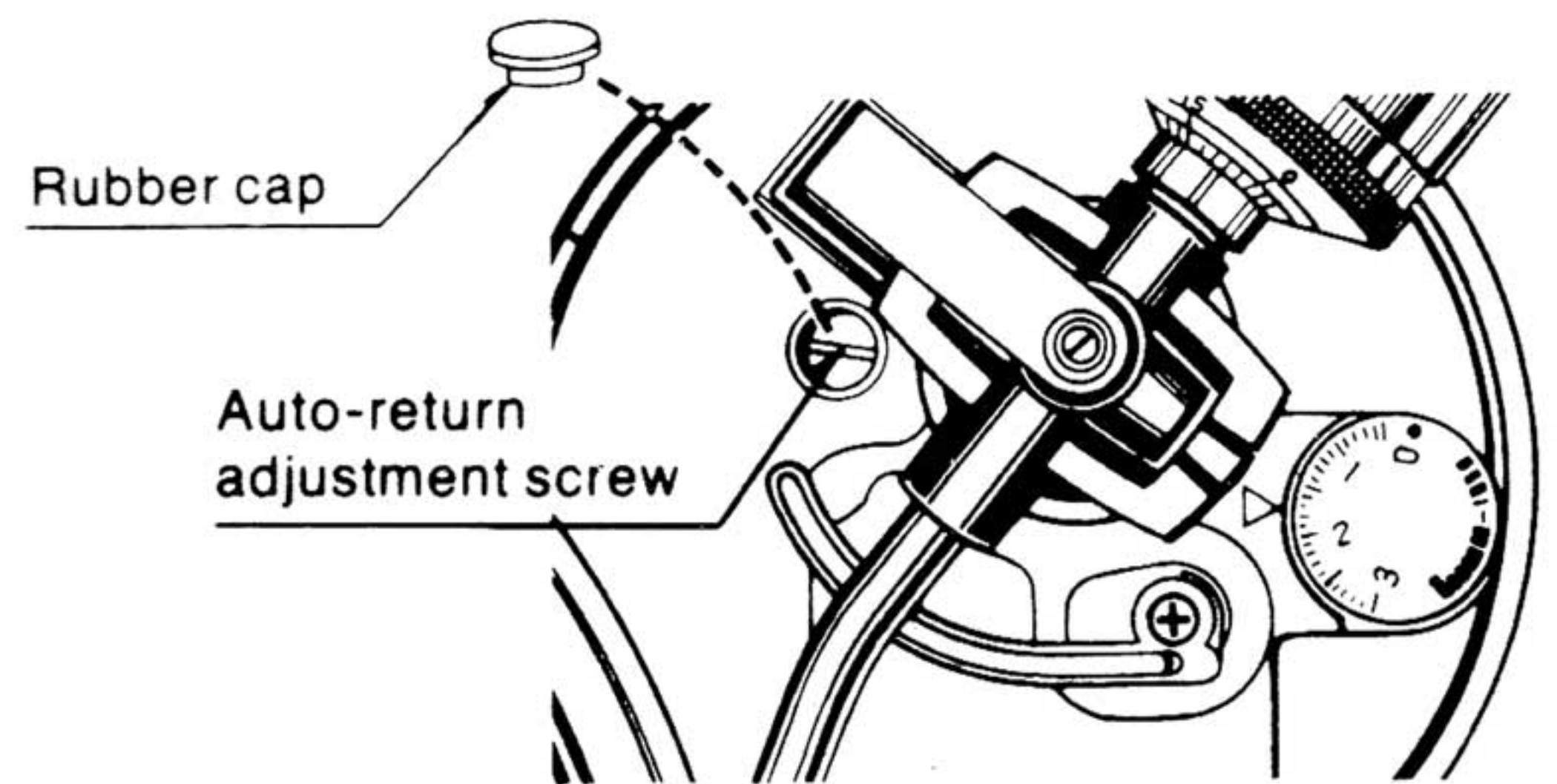

Fig. 11
(Abb. 11)

● Overhang adjustment (See Fig. 12)

15 mm is the correct overhang for this tonearm.

Loosen the screws and move the cartridge forward or backward until the distance between the stylus tip and the plug becomes 52 mm (2-3/64").

Tighten the screws without moving the cartridge.

Adjust the horizontal zero balance, stylus pressure and arm-lift height whenever you change the cartridge.

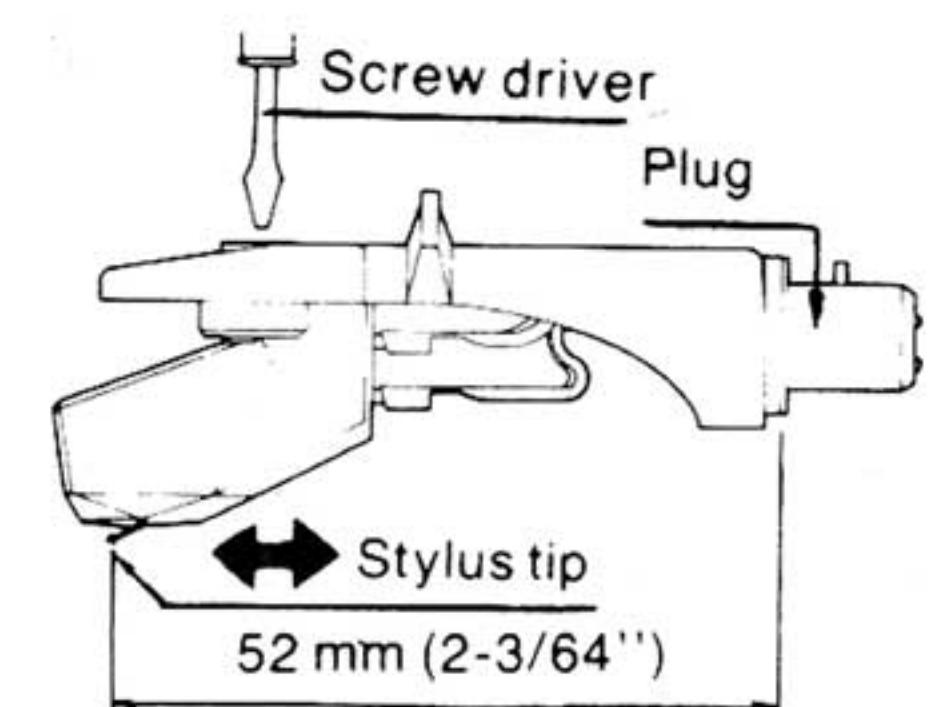

Fig. 12
(Abb. 12)

● Adjustment of rotational speed

After replacement of drive IC (IC101) and variable resistors (VR202, 203) or when the rated speed is not obtained by turning the pitch control knob, perform the adjustment according to the following procedure.

1. Remove the bottom board. (Refer to "Disassembly Instructions".)
2. Place the set on the player repair table.
3. Put on the record and play.
4. Push the speed selector button to "45 r.p.m.".
5. Turn the pitch control knob to central position. (See Fig. 13)
6. Adjust VR202 by the screwdriver from under the set until the rated speed (45 r.p.m.) is obtained while checking it through the stroboscope. (See Fig. 14)
7. Push the speed selector button to "33 r.p.m.".
8. Adjust VR203 by the screwdriver until the rated speed (33-1/3 r.p.m.) is obtained while checking it through the stroboscope. (See Fig. 14)
9. After completing the above-mentioned adjustment, check that the rated speeds can be obtained by pushing the speed selector button.

Note: Be sure to perform the adjustment of 45 r.p.m. first. As a simple method, it is also possible to adjust VR202 and VR203, removing the turntable. (See Fig. 15)

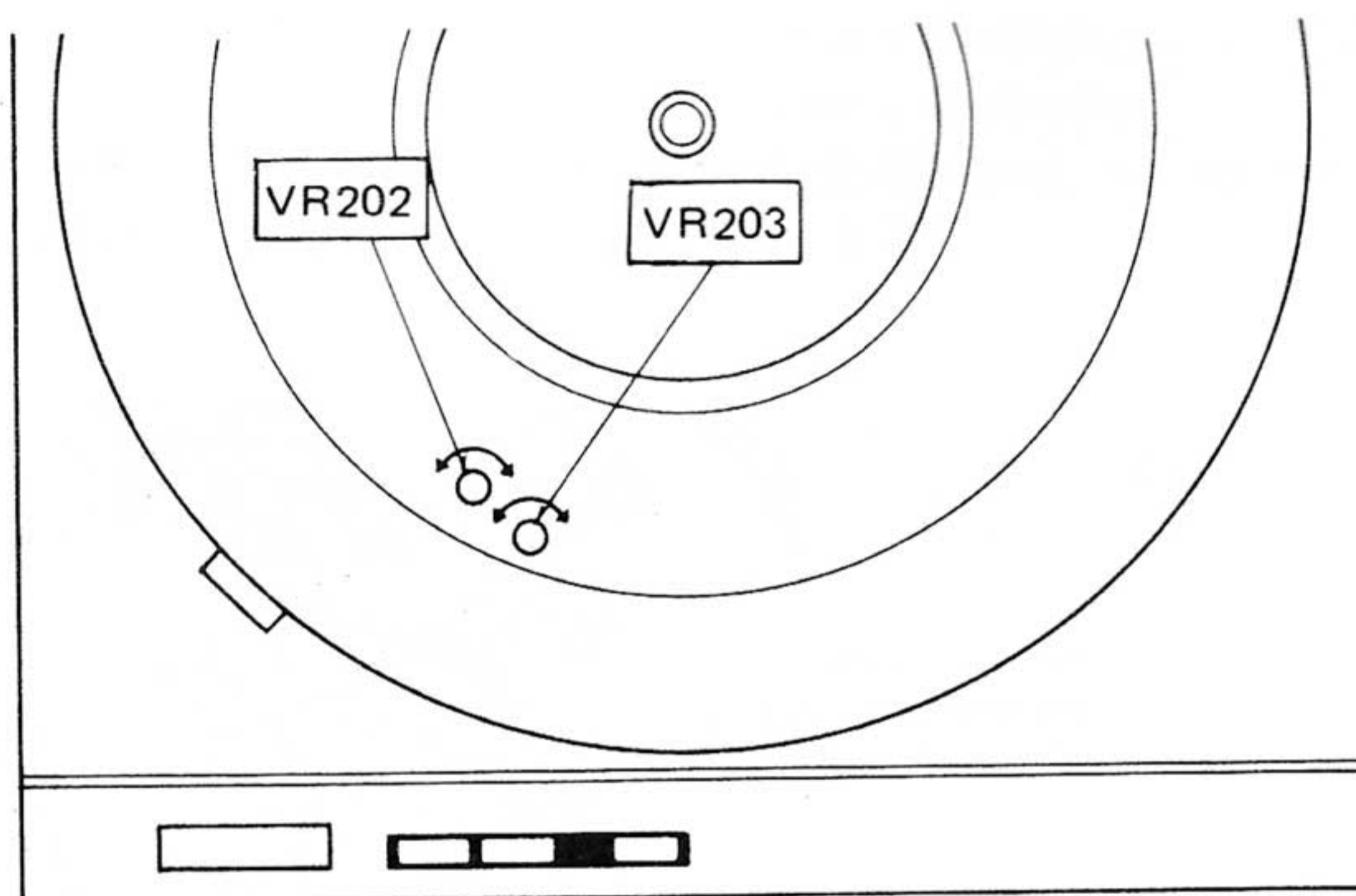

Fig. 15
(Abb. 15)

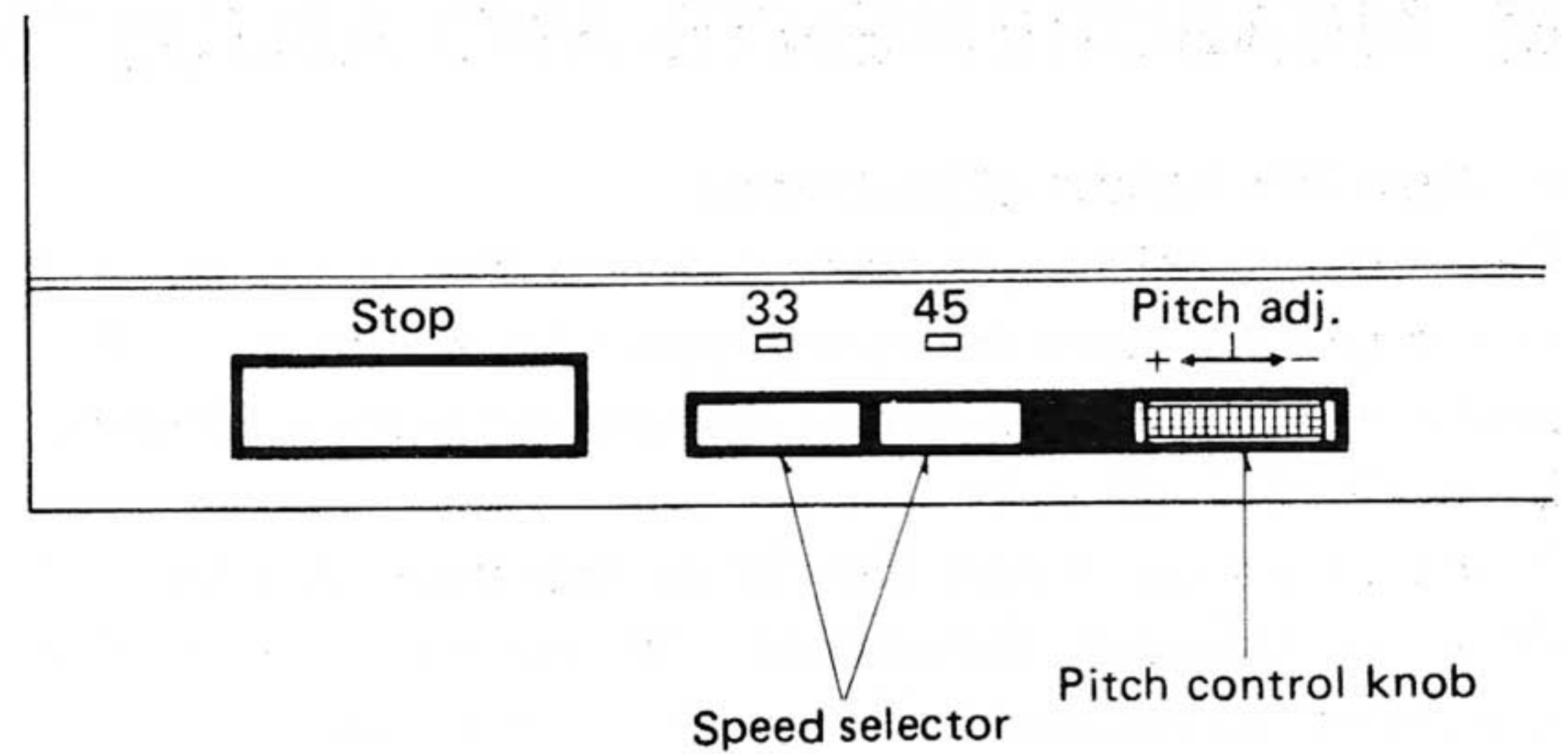

Fig. 13
(Abb. 13)

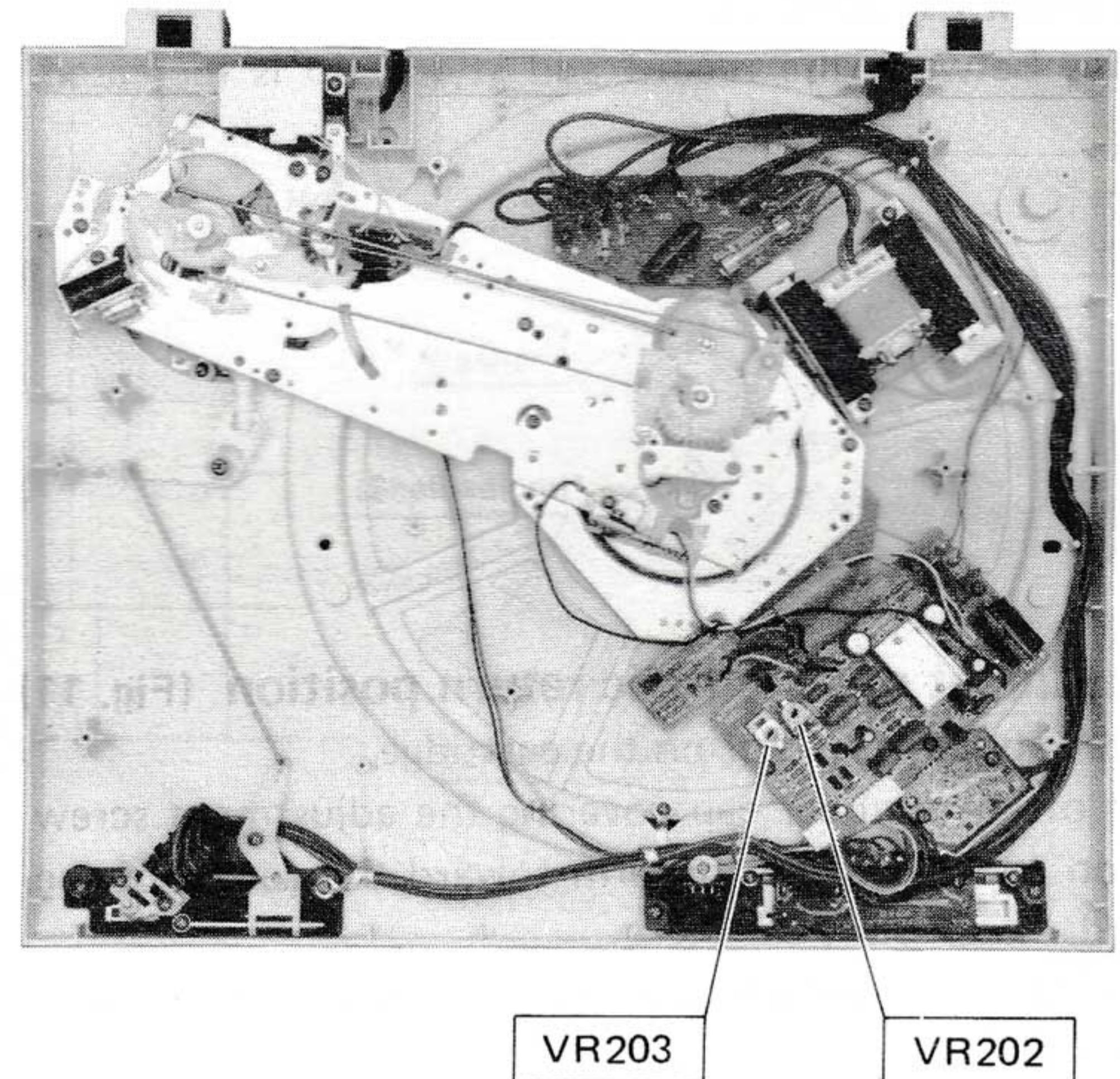

Fig. 14
(Abb. 14)

■ MESSUNGEN UND JUSTIERUNGEN ————— Deutsch

● Justierung der Tonarmlifthöhe

Die Tonarmlifthöhe, d.h. der Abstand zwischen Nadelspitze und Schallplattenoberfläche bei Liftsteuerungs-Position "▼", wurde werkseitig auf ca. 5 mm eingestellt. (Abb. 9)

Falls der Abstand zu klein oder zu groß ist (z.B. wegen der unterschiedlichen Tonabnehmer-Abmessungen, drehen Sie die Justierschraube im Uhrzeigersinn oder entgegen dem Uhrzeigersinn. (Abb. 10)

Drehung im Uhrzeigersinn

—Der Abstand zwischen der Platte und der Nadelspitze wird kleiner.

Drehung entgegen dem Uhrzeigersinn

—Der Abstand zwischen der Platte und der Nadelspitze wird größer.

● Justierung des Abschaltpunktes der Automatik (Abb. 11)

(Die Gummikappe abnehmen)

1. Setzen Sie den Nadelschutz auf den Tonabnehmer auf.
2. Führen Sie den Tonarm gegen die Plattenmitte.

Die Justierschraube für den Abschaltpunkt der Automatik wird dann sichtbar.

Falls der Tonarm zu früh zurückkehrt.

–Entgegen dem Uhrzeigersinn drehen.

Falls der Tonarm nach Erreichen der Auslaufrille nicht zurückkehrt.

–Im Uhrzeigersinn drehen.

● Justierung des Überhangs (Abb. 12)

Der korrekte Überhang für dieses Gerät beträgt 15 mm.

Lösen Sie die Befestigungsschrauben und versetzen Sie den Tonabnehmer vorwärts oder rückwärts, bis der Abstand zwischen dem Stecker und der Nadelspitze 52 mm beträgt.

Ziehen Sie die Befestigungsschrauben an, ohne dabei den Tonabnehmer zu verschieben.

Justieren Sie die horizontale "0"-Balance, die Auflagekraft und die Tonarmlifthöhe nach jedem Auswechseln des Tonabnehmers.

● Justierung der Drehzahl

Nach dem Ersetzen des Antriebs-IC (IC101) und der Drehwiderstände (VR202, VR203), oder wenn die Einstellung der Nenndrehzahl durch Drehen des Drehzahl-Feineinstellers nicht möglich ist, muß die Justierung auf folgende Weise vorgenommen werden.

1. Die Bodenplatte abnehmen. (Siehe "Anleitung für die Zerlegung".)
2. Das Gerät auf den Plattenspieler-Reparaturtisch stellen.
3. Eine Platte auflegen und abspielen.
4. Die Drehzahl-Wahlschaltertaste in die "45 U/min"-Position drücken.
5. Den Drehzahl-Feineinsteller in die Mittelstellung stellen. (Siehe Abb. 13)
6. VR202 mit einem Schraubenzieher von der Unterseite des Gerätes her drehen, bis die Nenndrehzahl (45 U/min) erreicht ist, und gleichzeitig auf den Stroboskop überprüfen. (Siehe Abb. 14)
7. Die Drehzahl-Wahlschaltertaste in die "33 U/min"-Position drücken.
8. VR203 mit einem Schraubenzieher drehen, bis die Nenndrehzahl (33-1/3 U/min) erreicht ist, und gleichzeitig auf dem Stroboskop überprüfen. (Siehe Abb. 14)
9. Nach Beenden der obigen Justierung überprüfen, daß die beiden Nenndrehzahlen durch Drücken der Drehzahl-Wahlschaltertaste erreicht werden können.
Anmerkung: Die Justierung für 45 U/min muß unbedingt zuerst durchgeführt werden.
10. Eine einfache mögliche Methode besteht darin, VR202 und VR203 nach Entfernen des Plattentellers zu justieren. (Siehe Abb. 15)

■ MESURAGES ET RÉGLAGES Français

● Mise au point de la hauteur de l'élévateur du bras

La hauteur de l'élévateur du bras (distance entre l'extrémité de la pointe de lecture et la surface du disque, lorsque la commande de pose et de relevage est à la position "▼") a été réglée en usine sur approximativement 5 mm. (Fig. 9)

Si l'intervalle est trop étroit ou trop large, (à cause, par exemple, des différentes dimensions de cellules pick-up), tourner la vis de réglage dans le sens des aiguilles d'une montre ou dans le sens inverse. (Fig. 10)

Rotation dans le sens des aiguilles d'une montre.

–La distance entre la surface du disque et l'extrémité de la pointe de lecture diminue.

Rotation dans le sens contraire des aiguilles d'une montre.

–La distance entre la surface du disque et l'extrémité de la pointe de lecture augmente.

● Mise au point de la position de retour automatique (Fig. 11)

(Retirer le capuchon en caoutchouc.)

1. Placer le capot protecteur de la pointe de lecture sur la cellule pick-up.

2. Déplacer le bras de lecture vers le centre de disque.

Alors, la vis de réglage du retour automatique apparaîtra.

Si le bras de lecture tend à revenir vers le support du bras avant que l'audition ne soit terminée.

–**Tourner dans le sens contraire des aiguilles d'une montre.**

Si le bras de lecture ne peut revenir en arrière après le dernier sillon.

–**Tourner dans le sens des aiguilles d'une montre.**

● Réglage du surplomb (Fig. 12)

Le surplomb approprié pour ce bras de lecture est de 15 mm.

Desserrer les vis et déplacer la cellule vers l'avant ou vers l'arrière jusqu'à ce que la distance entre l'extrémité de la pointe de lecture et la fiche soit de 52 mm.

Serrer les vis sans faire bouger la cellule.

Mettre au point l'équilibrage zéro horizontal, la force verticale d'appui de la pointe de lecture et la hauteur du bras élévateur chaque fois que vous changez de cellule.

● **Réglage de la vitesse rotationnelle**

Après le remplacement du circuit intégré excitateur (IC101) et des résistances variables (VR202, VR203) ou lorsque la vitesse nominale de rotation n'est pas obtenue en tournant la manette de réglage d'écart, effectuer la mise au point selon le mode opératoire suivant.

1. Retirer le panneau de la face inférieure. **(Se référer aux "Instructions de Démontage".)**
2. Placer l'appareil sur la table de dépannage pour électrophones.
3. Placer un disque et faire jouer.
4. Pousser la manette sélectrice de vitesse sur "45 r.p.m." (45 t/p.m.).
5. Tourner la manette de réglage d'écart sur la position centrale. **(Voir Fig. 13)**
6. Ajuster VR202 avec un tournevis à partir du dessous de l'appareil jusqu'à ce que la vitesse nominale de rotation (45 t/p.m.) soit obtenue tout en la vérifiant par l'intermédiaire du stroboscope. **(Voir Fig. 14)**
7. Pousser la manette sélectrice de vitesse sur "33 r.p.m." (33 t/p.m.).
8. Ajuster VR203 avec un tournevis jusqu'à ce que la vitesse nominale de rotation (33-1/3 t/p.m.) soit obtenue tout en la vérifiant par l'intermédiaire du stroboscope. **(Voir Fig. 14)**
9. Après avoir achevé la mise au point mentionnée cidessus, vérifier si les vitesses nominales de rotation peuvent être obtenues en poussant la manette sélectrice de vitesse.
Nota: S'assurer d'effectuer tout d'abord la mise au point de 45 t/p.m.
10. Comme méthode plus simplifiée, il est possible aussi d'ajuster VR202 et VR203 en retirant la platine. **(Voir Fig. 15)**

■ **MEDICIONES Y AJUSTES** **Español**

● **Ajuste de la altura de elevación del brazo**

La altura de elevación del brazo (o sea, la distancia entre la punta de la aguja y la superficie del disco cuando el control de colocación está en la posición "▼") ha sido regulada en la fábrica aproximadamente a 5 mm. **(Fig. 9)**

En caso que el espacio libre fuese demasiado estrecho o demasiado abundante (debido, por ejemplo, a la diferencia en dimensiones de los cartuchos), girar el tornillo de ajuste hacia la derecha o hacia la izquierda. **(Fig. 10)**

Rotación hacia la derecha

—reduce la distancia entre el disco y la punta de la aguja.

Rotación hacia la izquierda

—aumenta la distancia entre el disco y la punta de la aguja.

● **Ajuste de la posición para retorno automático (Fig. 11)**

(Quitar la tapita de goma.)

1. Colocar la protección de la aguja en el cartucho.
2. Mover el brazo sonoro hacia el centro del disco.

Con ello, aparecerá el tornillo de ajuste del retorno automático.

Cuando el brazo sonoro tienda a volver a su apoyo antes de terminar la ejecución:

—**Girar hacia la izquierda.**

En caso que el brazo sonoro no vuelva después de haber tocado el último surco del disco:

—**Girar hacia la derecha.**

● **Ajuste de la proyección (Fig. 12)**

La proyección correcta para este cartucho es de 15 mm.

Aflojar los tornillos y mover el cartucho para adelante y para atrás hasta que la distancia entre la punta de la aguja y la clavija sea de 52 mm.

Apretar los tornillos sin mover el cartucho.

Regular el equilibrio horizontal a cero, la presión de la aguja y la altura de elevación del brazo toda vez que se cambia el cartucho.

● **Ajuste de velocidad rotacional**

Después del reemplazo de IC de impulsión (IC101) y resistores variables (VR202, VR203) o cuando no se obtenga la velocidad nominal girando la perilla de control de altura, efectúe el ajuste según el siguiente procedimiento:

1. Remueva el tablero inferior. **(Refiera a "Instrucciones de Desmontaje".)**
2. Coloque el aparato sobre el banco de reparaciones para tocadiscos.
3. Ponga el disco y toque.
4. Apriete el botón selector de velocidad a "45 r.p.m.".
5. Gire la perilla de control de altura a la posición central. **(Vea la Fig. 13)**

6. Ajuste VR202 mediante el destornillador por debajo del aparato hasta que se obtenga la velocidad nominal (45 r.p.m.) mientras la verifica a través del estroboscopio. (Vea la Fig. 14)
7. Apriete el botón selector de velocidad a "33 r.p.m."
8. Ajuste VR203 mediante el destornillador hasta que se obtenga la velocidad nominal (33-1/3 r.p.m.) mientras la verifica a través del estroboscopio. (Vea la Fig. 14)
9. Después de completar el ajuste mencionado arriba, compruebe que las velocidades nominales se puedan obtener apretando el botón selector de velocidad.
Nota: Asegúrese de efectuar el ajuste de 45 r.p.m. primero.
10. Como un método simple, es posible también ajustar VR202 y VR203, removiendo el plato giradiscos. (Vea la Fig. 15)

■ BLOCK DIAGRAM

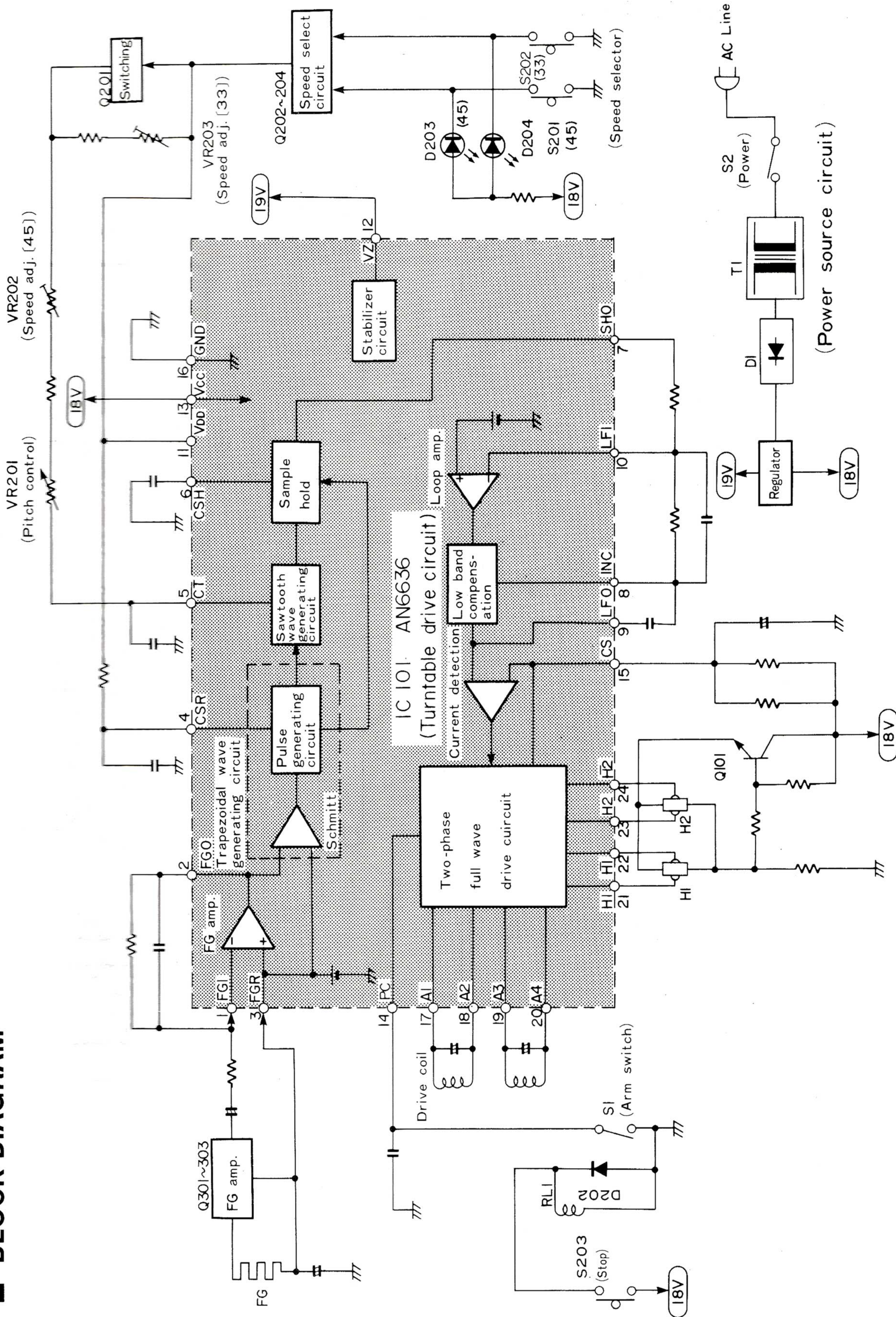

CIRCUIT BOARD AND WIRING CONNECTION DIAGRAM

Ground (Earth) lines

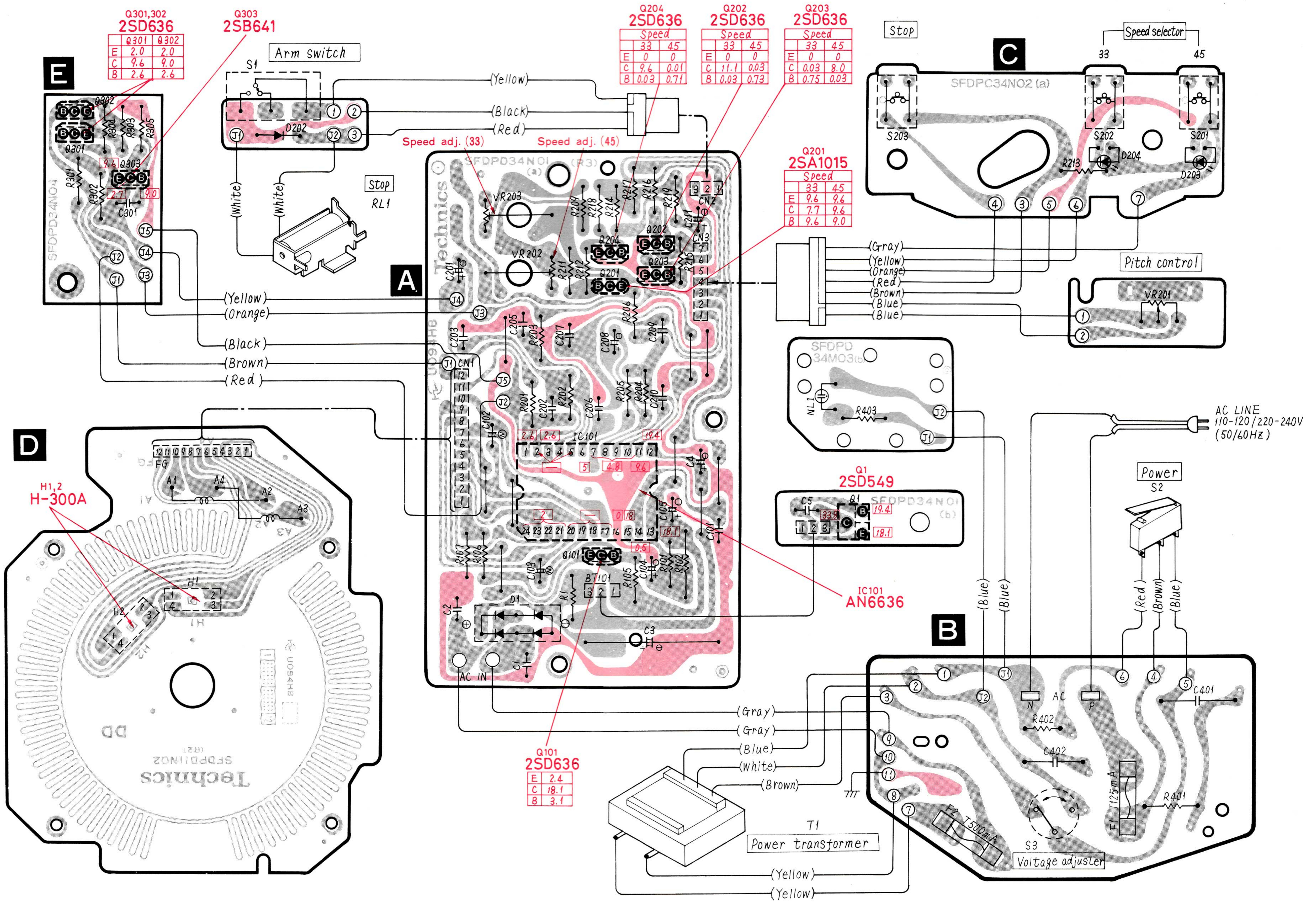

SCHEMATIC DIAGRAM

(This schematic diagram may be modified at any time with the development of new technology.)



Notes:

- S1** : Arm switch in "on" position.
- S2** : Power switch in "on" position.
- S3** : Voltage adjuster switch in "220 - 240V" position.
110V - 120V ↔ 220V - 240V
- S201** : Speed selector (45) switch in "off" position.
(not push condition)
- S202** : Speed selector (33) switch in "off" position.
(not push condition)
- S203** : Stop switch in "off" position.
(not push condition)
- The value in is the standard voltage for this unit operated at 33-1/3r.p.m., which was measured by DC electronic voltmeter (high impedance) on the basis of the chassis. Accordingly, the voltage value may sometimes include a slight error depending on the internal impedance of the DC voltmeter (tester, etc.) used for the measurement.
- + \oplus voltage line.
- Important safety Notice:**
Components identified by \triangle mark have special characteristics important safety. When replacing any of these components, use only manufacturer's specified parts.

Reference voltage and waveform at each IC terminal (Pin)

This indicated voltage values and waveform are measured by oscilloscope at 33r.p.m. rotation.

IC101 (AN6636)

| Pin No. | Stop | Start | Pin No. | Stop | Start | Pin No. | Stop | Start |
|---------|------|-------|---------|-------|-------|---------|------|-------|
| ① | 2.6V | 2.6V | ⑦ | 8.0V | | ⑬ | 0V | |
| ② | 2.6V | | ⑧ | 0.2V | 4.8V | ⑭ | 2.1V | |
| ③ | 2.6V | 2.6V | ⑨ | 0.2V | 4.8V | ⑮ | 2.0V | |
| ④ | 9.4V | | ⑩ | 4.8V | 4.8V | ⑯ | 0V | |
| ⑤ | 8.8V | | ⑪ | 9.6V | 9.6V | ⑰ | 3.0V | |
| ⑥ | 8.2V | | ⑫ | 19.4V | 19.4V | ⑱ | 0V | |
| | | | ⑬ | 18.1V | 18.1V | ⑳ | 0V | |
| | | | ⑭ | 0V | 0.5V | ㉑ | 0V | |
| | | | ⑮ | 18.1V | 18.0V | ㉒ | 0V | |
| | | | | | | ㉓ | 0V | |

| Q201 | Speed | Q202 | Speed | Q203 | Speed | Q204 | Speed |
|------|---------|------|-----------|------|-----------|------|-----------|
| | 33 45 | | 33 45 | | 33 45 | | 33 45 |
| E | 9.4 9.6 | E | 0 0 | E | 0 0 | E | 0 0 |
| C | 7.7 9.6 | C | 11.1 0.03 | C | 0.03 8.0 | C | 9.6 0.01 |
| B | 9.4 9.5 | B | 0.02 0.73 | B | 6.75 6.03 | B | 0.03 0.71 |

Terminal guide of transistors and IC's

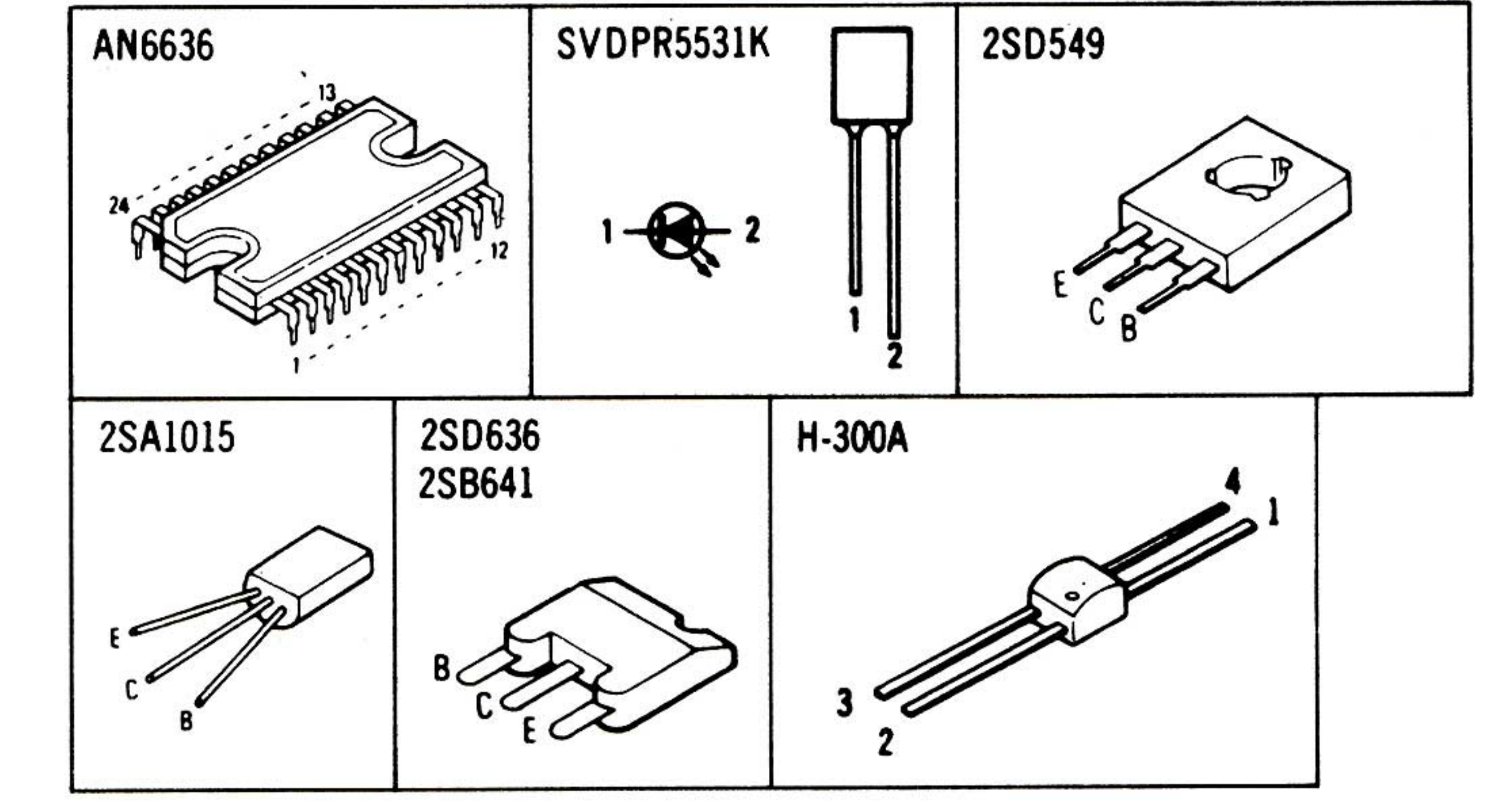

EXPLODED VIEWS.....Cabinet & Chassis

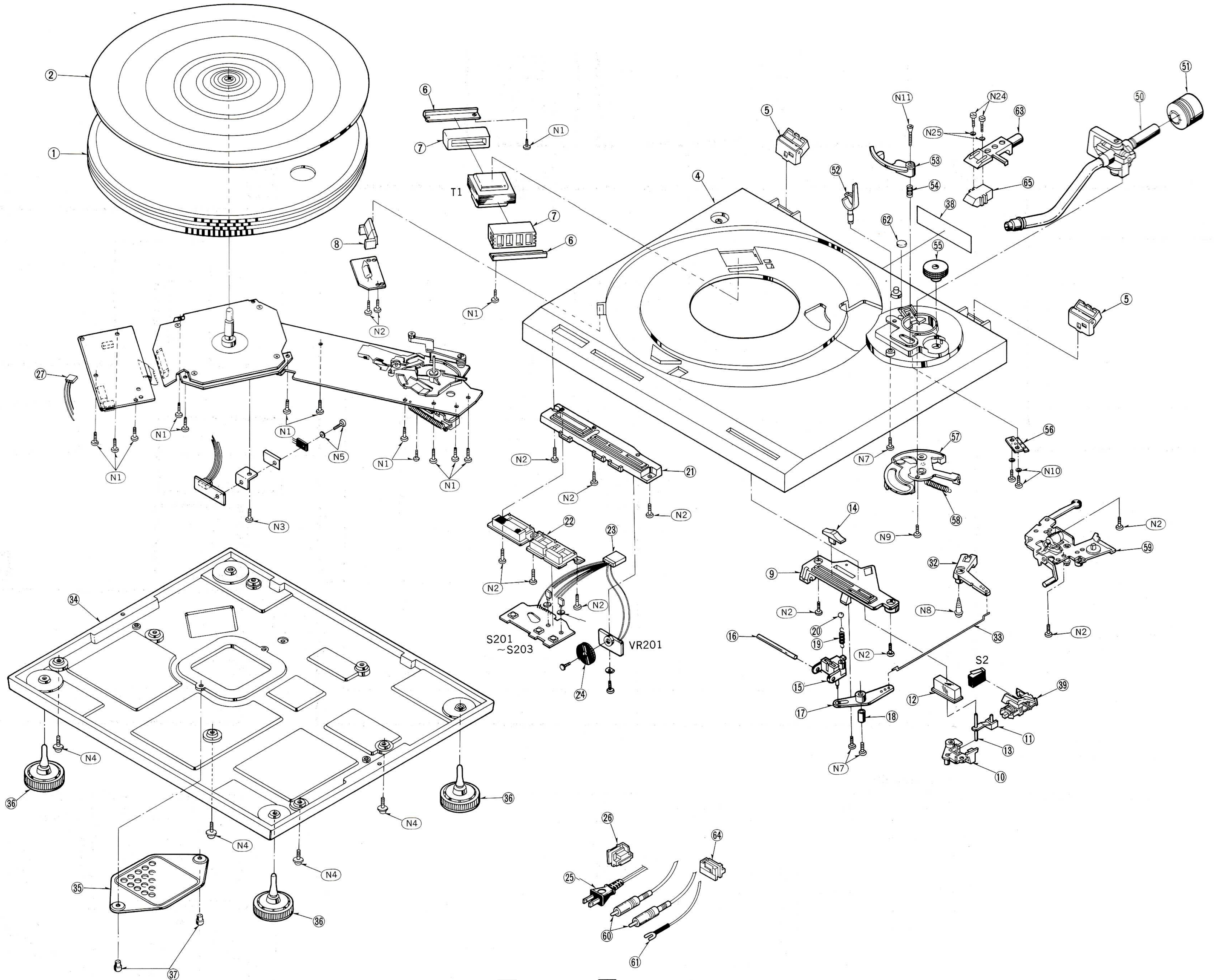

REPLACEMENT PARTS LIST...Cabinet, Chassis and Packing Parts

- Notes:**
1. Part numbers are indicated on most mechanical parts. Please use this part number for parts orders.
 2. Important safety notice: Components identified by **△** mark have special characteristics important for safety. When replacing any of these components, use only manufacturer's specified parts.
 3. **Ⓚ**-marked parts are used for black type only, while **○**-marked parts are for silver type only.

4. Parts other than **Ⓚ** and **○**-marked are used for both black and silver types.
5. Bracketed indications in Ref. No. columns specify the area. Parts without these indications can be used for all areas.

Black type model No. : SL-D202 (K)

| Ref. No. | Part No. | Part Name & Description |
|----------------------------|----------------------|----------------------------------|
| CABINET and CHASSIS | | |
| 1 | SFTED22N01E | Turntable |
| 2 | SFTGQ22N01 | Turntable Mat |
| 4 | SFACD22N01 | Cabinet (Silver) |
| 4 | Ⓚ SFACD22N21 | Cabinet (Black) |
| 5 | SFATB33N01A | Hinge |
| 6 | SFUPD34N01 | Plate, Transformer |
| 7 | SFGCD34N01 | Rubber Cushion, Transformer |
| 8 | SFUMQ11N09 | Cover, Neon Lamp Strobe |
| 9 | SFUMQ34N02 | Guide, Power Switch |
| 10 | SFUMQ34N12 | Plate, Power Switch |
| 11 | SFUMQ34N13 | Plate, Power Knob |
| 12 | SFKTQ34N02 | Knob, Power Switch |
| 13 | SFXJQ34N02 | Shaft, Power Switch |
| 14 | SFKTQ34N01 | Knob, Cueing |
| 15 | SFUMQ34N23 | Slider, Cueing |
| 16 | SFXJQ34N01 | Shaft, Cueing |
| 17 | SFUMQ34N04 | Rink, Cueing (A) |
| 18 | SFXOQ34N01 | Pipe, Cueing |
| 19 | SFQA130-11 | Spring, Cueing |
| 20 | SFYB-5-32 | Ball, Cueing |
| 21 | SFUMD34N01 | Guide, Stop |
| 22 | SFKTQ34N03 | Knob, Stop |
| 23 | SFDJD34N03E | Connector Ass'y 7P |
| 24 | SFKTD11N01 | Knob, Speed Adjustment |
| 25 [XL] | △ SJA141 | AC Cord |
| 25 [EK] | △ SJA139 | AC Cord |
| 25 [Other Areas] | △ SJA137 | AC Cord |
| 26 [Other Areas] | SFUM190-11 | Bushing, AC Cord |
| 26 [XL] only | SFUM190-12 | Bushing, AC Cord |
| 27 | SFDJD34N01E | Connector Ass'y 3P |
| 32 | SFUMB33N11 | Rink, Cueing (B) |
| 33 | SFUZQ34N02 | Rod, Cueing |
| 34 | SFAUD34N01 | Bottom Board |
| 35 | SFUPQ34N01 | Gear, Cover |
| 36 | SFGAD34N01 | Audio Insulator |
| 37 | SFUZQ34N06E | Latch, Gear Cover |
| 38 [E] | SFNND22S01 | Name Plate |
| 38 [EK, XL] | SFNND22G02 | Name Plate |
| 38 [XA, XM] | SFNND22X01 | Name Plate |
| 38 [Other Areas] | SFNND22R01 | Name Plate |
| 39 | SFDSTWM9901A | Power Switch |
| | SFADB33N01E | Dust Cover |
| TONE ARM PARTS | | |
| 50 | ○ SFPAM30301A | Tone Arm (Silver) |
| 50 | Ⓚ SFPAM30302A | Tone Arm (Black) |
| 51 | SFPWG30301A | Counter weight |
| 52 | SFPRT30301E | Arm Rest |
| 53 | SFPRT30302E | Lift Arm |
| 54 | SFPSP30304 | Spring, Lift Arm |
| 55 | SFPJK30301 | Knob, Anti-Skate Force Control |
| 56 | SFUPD34N02 | Sub Plate Tone Arm |
| 57 | SFPAB30301A | Plate, Tone Arm |
| 58 | SFPSP30302 | Spring, Anti-Skate Force Control |
| 59 | SFPAB30305A | Plate, Lift Ass'y |

| Ref. No. | Part No. | Part Name & Description |
|-------------------------------------|---------------------|--|
| 60 | SFDH212-01 | Phono Cord |
| 61 | SFEL028-01E | Ground Wire |
| 62 | ○ SFGK170-01 | Rubber, Cap (Silver) |
| 62 | Ⓚ SFGK171F01 | Rubber, Cap (Black) |
| 63 | SFPCC31002K | Head Shell |
| 64 | SFUM212-08 | Bushing, Phono Cord |
| 65 | EPC-U25S | Cartridge **Not Available as Parts, Please |
| | EPS-25CS | Stylus Order to Sales Department |
| SCREWS, WASHERS and CIRCLIPS | | |
| N1 | XTV3+10BFN | Screw, Tapping, ⊕ 3 x 10 |
| N2 | XTV3+8BFN | Screw, Tapping, ⊕ 3 x 8 |
| N3 | XTV3+6BFN | Screw, Tapping, ⊕ 3 x 6 |
| N4 | XTWS3+20QFYR | Screw, Tapping, ⊕ 3 x 20 |
| N5 | XYN3+C8S | Screw, Tapping, ⊕ 3 x 8 |
| N6 | SFXWQ11N03 | Washer |
| N7 | XTW3+10Q | Screw, Tapping, ⊕ 3 x 10 |
| N8 | SFXGQ20-01 | Screw |
| N9 | SFXGQ34N02 | Screw |
| N10 | XYN3+C12S | Screw, Tapping, ⊕ 3 x 12 |
| N11 | XTS3+16BFZ | Screw, Tapping, ⊕ 3 x 16 |
| N12 | XTW3+8E | Screw, Tapping, ⊕ 3 x 8 |
| N15 | XUC3FT | Circlip, φ3 |
| N16 | XUB4FT | Circlip, φ2 |
| N17 | SFXWQ34N26 | Washer |
| N18 | SFXWQ30-11 | Washer |
| N19 | XUC5FT | Circlip, φ5 |
| N20 | XWE4BW | Washer |
| N21 | SFXWQ34N21 | Washer |
| N22 | XTV3+6BFN | Screw, Tapping, ⊕ 3 x 6 |
| N23 | XUC2FT | Circlip, φ2 |
| N24 | SFCZV8800 | Screw, Cartridge |
| N25 | SFPEW9601 | Washer, Cartridge |
| ACCESSORIES | | |
| A1 [E] | SFNUD22S01 | Instructions Book, Printed Matter |
| A1 [EK] | SFNUD22G01 | Instructions Book, Printed Matter |
| A1 [Other Areas] | SFNUD22X01 | Instructions Book, Printed Matter |
| A2 | SFWE212-01 | Adaptor, 45r.p.m. |
| A3 | SFCZB30505 | Shell Weight |
| A4 [XA, XM] | SFDKI19118 | 2 Pin Plug, Power Source |
| PACKING PARTS | | |
| P1 | ○ SFHPD22M01 | Carton Box (Silver) |
| P1 [EF] only | ○ SFHPD22C01 | Carton Box (Silver) |
| P1 | Ⓚ SFHPD22M21 | Carton Box (Black) |
| P1 [EF] only | Ⓚ SFHPD22J21 | Carton Box (Black) |
| P2 | SFHHQ34N01 | Pad, Front |
| P3 | SFHHQ34N02 | Pad, Rear |
| P4 | SFHDQ34N01 | Pad, Turntable |
| P5 | SFHZ144X02 | Sheet |
| P6 | SFYH60X60 | Polyethylene Bag, Unit/Dust Cover |
| P7 | SFYH40X45 | Polyethylene Bag, Turntable |
| P8 | SPB1083 | Polyethylene Bag, Accessories |
| P9 | SPJ15 | Polyethylene Bag, 45 Adaptor |
| P10 [XA, XM] | SFHDQ34X01 | Front, Pad |
| P11 [XA, XM] | SFHDQ34X02 | Rear, Pad |

REPLACEMENT PARTS LIST...Electrical Parts

- Notes:**
1. Part numbers are indicated on most mechanical parts. Please use this part number for parts orders.
 2. Important safety notice:
Components identified by Δ mark have special characteristics important for safety. When replacing any of these components, use only manufacturer's specified parts.
 3. Bracketed indications in Ref. No. columns specify the area.
Parts without these indications can be used for all areas.

Areas

- * [E] is available in Switzerland and Scandinavia.
- * [EK] is available in United Kingdom.
- * [XL] is available in Australia.
- * [EG] is available in F.R. Germany.
- * [EB] is available in Belgium.
- * [EF] is available in France.
- * [XA] is available in Southeast Asia, Oceania, Africa, Middle Near East and Central South America.
- * [XM] is available in Central South America.
- * [EH] is available in Holland.
- * [Ei] is available in Italy.
- * [EC] is available in Czechoslovakia.

| Ref. No. | Part No. | Part Name & Description |
|---------------------------|-----------------------|---|
| INTEGRATED CIRCUIT | | |
| IC101 | AN6636 | IC, Drive |
| TRANSISTORS | | |
| Q1 | 2SD549 | Transistor, Regulator |
| Q101, 301, 302 | 2SD636 | Transistor, Regulator & FG Amplifier |
| Q201 | 2SA1015-Y | Transistor, Switching |
| Q202, 203, 204 | 2SD636 | Transistor, Speed Selector & Switching |
| Q303 | 2SB641 | Transistor, FG Amplifier |
| DIODES | | |
| D1 | Δ SVDS1RBA20Z | Diode, Rectifier |
| D202 | SVDRM1Z | Diode |
| D203, 204 | SVDPR5531K | Light Emitting, Speed Indicator |
| HALL ELEMENT | | |
| H1, 2 | H-300A | Hall Element, Turntable Position Detector |
| LAMP | | |
| NL1 | Δ SFDNE2HU | Neon Lamp, Strobe |
| SOLENOID | | |
| RL1 | SFDZQ34N01Z | Solenoid Ass'y, Start/Stop |
| VARIABLE RESISTORS | | |
| VR201 | EVLEAAT12B24 | Pitch Control 20k Ω (B) |
| VR202 | EVTS3MA00B54 | Speed Adjustment 45 r.p.m. 50k Ω (B) |
| VR203 | EVTS3MA00B24 | Speed Adjustment 33 r.p.m. 20k Ω (B) |
| SWITCHES | | |
| S1 | SFDSA2985 | Switch, Arm (Rest) Switch |
| S2 | Δ SFSS5GLP | Switch, Power Source |
| S3 | Δ SFDSHXW01335 | Switch, Voltage Adjuster |
| S201, 202, 203 | EVQJR02K | Switch, Start/Stop & Speed Selector |
| TRANSFORMER | | |
| T1 | Δ SLT57P25E | Transformer, Power Source |
| FUSES | | |
| F1 | Δ XBA2C012T1A | Fuse, T 0.12A 250V |
| F2 | Δ XBA2C05TR0 | Fuse, T 0.5A 250V |

| Ref. No. | Part No. | Part Name & Description |
|-------------------------------|-----------------------------|---|
| RESISTORS | | |
| R1 | ERD25FJ103 | Carbon, 1/4W, 10k Ω , \pm 5% |
| R101 | ERD25FJ220 | Carbon, 1/4W, 22 Ω , \pm 5% |
| R102 | ERX1ANJ2R2 | Metal Oxide, 1W, 2.2 Ω , \pm 5% |
| R105 | ERD25FJ472 | Carbon, 1/4W, 4.7k Ω , \pm 5% |
| R106 | ERD25FJ471 | Carbon, 1/4W, 470 Ω , \pm 5% |
| R107 | ERD25FJ221 | Carbon, 1/4W, 220 Ω , \pm 5% |
| R201 | ERD25FJ102 | Carbon, 1/4W, 1k Ω , \pm 5% |
| R202 | ERD25TJ153 | Carbon, 1/4W, 15k Ω , \pm 5% |
| R203 | ERD25TJ333 | Carbon, 1/4W, 33k Ω , \pm 5% |
| R204 | ERD25TJ104 | Carbon, 1/4W, 100k Ω , \pm 5% |
| R205 | ERD25TJ473 | Carbon, 1/4W, 47k Ω , \pm 5% |
| R206 | ERO25CKF6802 | Metal Film, 1/4W, 68k Ω , \pm 1% |
| R209 | ERD25TJ273 | Carbon, 1/4W, 27k Ω , \pm 5% |
| R211 | ERD25FJ471 | Carbon, 1/4W, 470 Ω , \pm 5% |
| R212 | ERD25FJ472 | Carbon, 1/4W, 4.7k Ω , \pm 5% |
| R213 | ERD25FJ152 | Carbon, 1/4W, 1.5k Ω , \pm 5% |
| R214, 215 | ERD25FJ682 | Carbon, 1/4W, 6.8k Ω , \pm 5% |
| R216, 217 | ERD25FJ472 | Carbon, 1/4W, 4.7k Ω , \pm 5% |
| R218 | ERD25FJ682 | Carbon, 1/4W, 6.8k Ω , \pm 5% |
| R219 | ERD25FJ100 | Carbon, 1/4W, 10 Ω , \pm 5% |
| R301 | ERD25FJ102 | Carbon, 1/4W, 1k Ω , \pm 5% |
| R302 | ERD25TJ153 | Carbon, 1/4W, 15k Ω , \pm 5% |
| R303 | ERD25FJ681 | Carbon, 1/4W, 680 Ω , \pm 5% |
| R304, 305 | ERD25FJ471 | Carbon, 1/4W, 470 Ω , \pm 5% |
| R401 | Δ ERD50FJ4R7 | Carbon, 1/2W, 4.7 Ω , \pm 5% |
| R402 | Δ ERD25FJ102 | Carbon, 1/4W, 1k Ω , \pm 5% |
| R403 | Δ ERG1ANJ103 | Metal Oxide, 1W, 10k Ω , \pm 5% |
| CAPACITORS | | |
| C1, 2 | Δ ECKD1H223PF | Ceramic, 50V, 0.022 μ F, \pm 10% |
| C3 | ECEB1HS471 | Electrolytic, 50V, 470 μ F |
| C4 | ECEA25Z4R7 | Electrolytic, 25V, 4.7 μ F |
| C5 | ECKD1H223PF | Ceramic, 50V, 0.022 μ F, \pm 10% |
| C101 | Δ ECQM1H333JZ | Polyester, 50V, 0.033 μ F, \pm 5% |
| C102, 103 | Δ ECEA1CN101S | Non-Polar Electrolytic, 16V, 100 μ F |
| C104 | ECEA1ES470 | Electrolytic, 25V, 47 μ F |
| C105 | ECEA1VS330 | Electrolytic, 35V, 33 μ F |
| C201 | ECEA50Z3R3 | Electrolytic, 50V, 3.3 μ F |
| C202 | ECQM1H104JZ | Polyester, 50V, 0.1 μ F, \pm 5% |
| C203 | ECQM1H473JZ | Polyester, 50V, 0.047 μ F, \pm 5% |
| C205 | ECQM1H333JZ | Polyester, 50V, 0.033 μ F, \pm 5% |
| C206 | ECQM1H104JZ | Polyester, 50V, 0.1 μ F, \pm 5% |
| C207 | ECQM1H224JZ | Polyester, 50V, 0.22 μ F, \pm 5% |
| C208 | ECEA25Z4R7 | Electrolytic, 25V, 4.7 μ F |
| C209 | ECQM1H104JZ | Polyester, 50V, 0.1 μ F, \pm 5% |
| C210 | ECQM1H224JZ | Polyester, 50V, 0.22 μ F, \pm 5% |
| C211 | ECEA25Z4R7 | Electrolytic, 25V, 4.7 μ F |
| C301 | ECCD1H330K | Ceramic, 50V, 33pF, \pm 10% |
| C401 [EG, EB, XA, EF, EH, EI] | Δ ECQE2A473MZ | Polyester, 250VAC, 0.047 μ F, \pm 20% |
| C401 [E, EC, EK, XL] | Δ ECQU2A473MF | Polyester, 250VAC, 0.047 μ F, \pm 20% |
| C402 [EK, Ei, EH] | Δ ECQE2A103MZ | Polyester, 250VAC, 0.01 μ F, \pm 20% |

PACKINGS

