

# SERVICE MANUAL

PURE POWER DC STEREO RECEIVER

## SANSUI G-5500

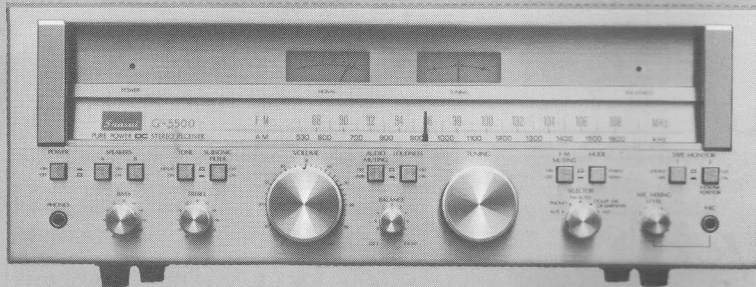

**Sansui**

SANSUI ELECTRIC CO., LTD.

### SPECIFICATIONS

#### Audio section

##### Power output

Min. RMS, both channels driven, from 20 to 20,000 Hz with no more than 0.03 % total harmonic distortion.

60 watts per channel into 8 ohms

Load impedance . . . . . 8 ohms

##### Total harmonic distortion

. . . . . less than 0.03 % at or below rated min. RMS power output

Intermodulation distortion (70 Hz : 7 kHz = 4:1 SMPTE method)

. . . . . less than 0.03 % at or below rated min. RMS power output

##### Frequency response (at 1 watt)

Overall (from AUX) . . . 5 to 50 kHz +0.2 dB, -2.0 dB

##### Power amplifier section

. . . . . DC to 200,000 Hz, +0 dB, -3.0 dB

Rise time . . . . . 1.4  $\mu$ sec

Slew rate . . . . . 56 V/ $\mu$ sec

RIAA curve deviation (PHONO, 20 Hz to 20 kHz)

. . . . . +0.2 dB, -0.2 dB

Damping factor (20 Hz to 20 kHz, both channels driven)

. . . . . 50 into 8 ohms

##### Input sensitivity and impedance (at 1 kHz)

PHONO . . . . . 2.5 mV/47 kilohms

(Max. input capability: 220 mV at 1 kHz, less than 0.1% total harmonic distortion.)

MIC . . . . . 6 mV/10 kilohms

TAPE-1, 2 PLAY, AUX

. . . . . 150 mV/47 kilohms

##### Output level (at 1 kHz)

TAPE-1, 2 REC (pin jacks)

. . . . . 150 mV

TAPE-2 REC/PLAY (DIN socket)

. . . . . 43 mV

##### Hum and noise (short-circuit, A-network)

PHONO . . . . . 78 dB

TAPE-1, 2 PLAY, AUX

. . . . . 95 dB

##### Channel separation (at 1 kHz)

PHONO . . . . . 55 dB

TAPE-1, 2 PLAY, AUX

. . . . . 65 dB

##### Controls

BASS . . . . .  $\pm 10$  dB at 50 Hz

TREBLE . . . . .  $\pm 10$  dB at 10 kHz

SUBSONIC FILTER . . . -3 dB at 16 Hz (6 dB/oct)

LOUDNESS (VOLUME control: -30 dB position)

. . . . . 8 dB at 50 Hz

. . . . . 6 dB at 10 kHz

AUDIO MUTING . . . -20 dB

#### FM section

Tuning range . . . . . 88 to 108 MHz

##### Usable sensitivity

Mono IHF . . . . . 10.8 dBf (1.9  $\mu$ V)

DIN . . . . . 1.1  $\mu$ V

Stereo IHF . . . . . 18 dBf

##### 50 dB quieting sensitivity

Mono . . . . . 15 dBf

Stereo . . . . . 37 dBf

##### Signal to noise ratio (at 65 dBf)

Mono . . . . . 72 dB

Stereo . . . . . 68 dB

##### Distortion (at 65 dBf)

Mono . . . . . less than 0.15 % at 100 Hz

. . . . . less than 0.13 % at 1,000 Hz

. . . . . less than 0.25 % at 6,000 Hz

Stereo . . . . . less than 0.25 % at 100 Hz

. . . . . less than 0.18 % at 1,000 Hz

. . . . . less than 0.25 % at 6,000 Hz

##### Alternate channel selectivity (at 400 kHz)

. . . . . 70 dB

Capture ratio . . . . . 1.0 dB

Image response ratio . . . 50 dB

Spurious response ratio . . 80 dB

IF response ratio . . . . . 75 dB

Stereo separation . . . . . 35 dB at 100-Hz

. . . . . 40 dB at 1,000 Hz

. . . . . 28 dB at 10,000 Hz

. . . . . 20 dB from 30 to 15,000 Hz

Frequency response . . . . 30 to 15,000 Hz

. . . . . +0.2 dB, -1.0 dB

##### Antenna input impedance

. . . . . 300 ohms balanced

. . . . . 75 ohms unbalanced

to be continued

**Specifications**

**AM section**

Tuning range . . . . . 530 to 1,600 kHz  
 Usable sensitivity (bar antenna) . . . . . 50 dB/m (300 μV/m)  
 Selectivity (±10 kHz) . . . . . 35 dB  
 Signal to noise ratio . . . . . 48 dB  
 Distortion (at 30 % Modulation, 80 dB/m) . . . . . less than 0.5 %

**Others**

Power requirements  
 Power voltage . . . . . 100, 120, 220, 240 V (50/60 Hz)  
 For U.S.A. and Canada . . . . . 120 V (60 Hz)  
 Power consumption  
 Rated consumption 200 watts 240 VA

Dimensions . . . . . 464 mm (18-5/16") W  
 181 mm (7-3/16") H  
 408 mm (16-1/8") D  
 Weight . . . . . 12.8 kg (28.2 lbs) net  
 15.0 kg (33.1 lbs) packed

\* Design and specifications subject to change without notice for improvements.

**1. BLOCK DIAGRAM**

**1-1. Tuner Section (F-2590)**

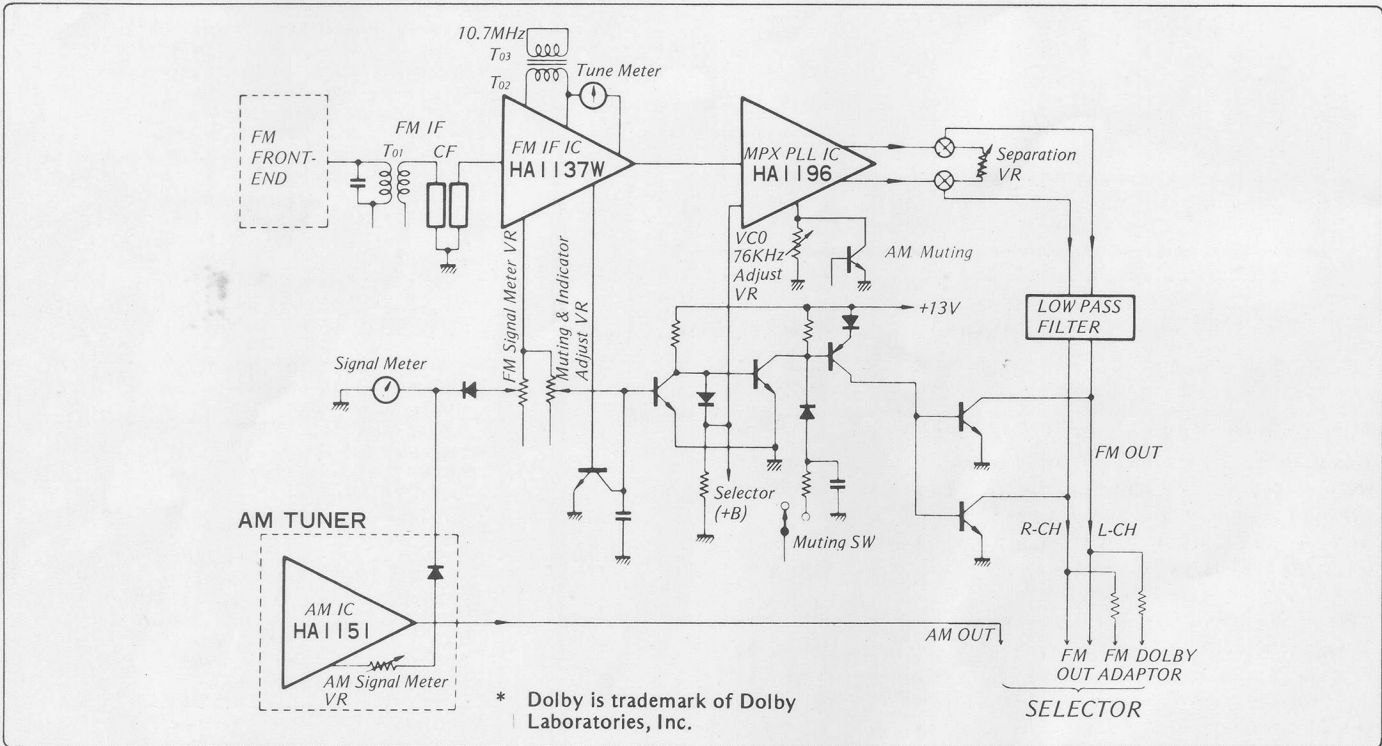

**1-2. Audio Section (L-CH)**

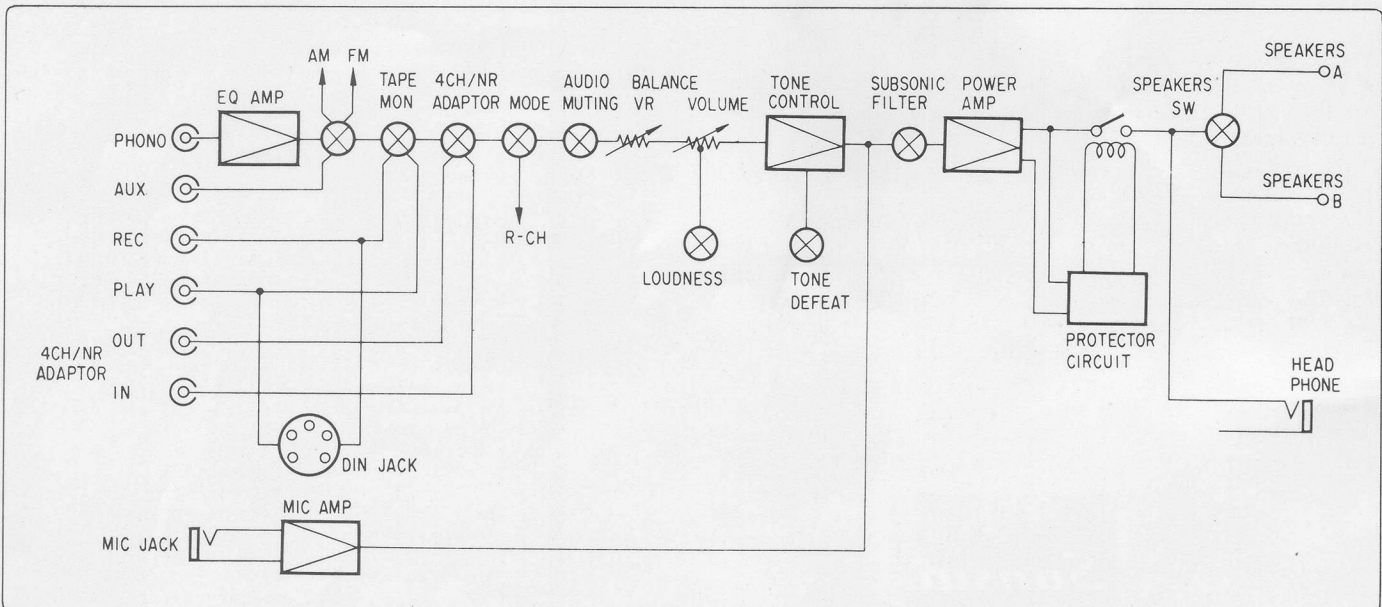

## 2. OPERATION

### 2-1. Protector Circuit with IC, HA12002

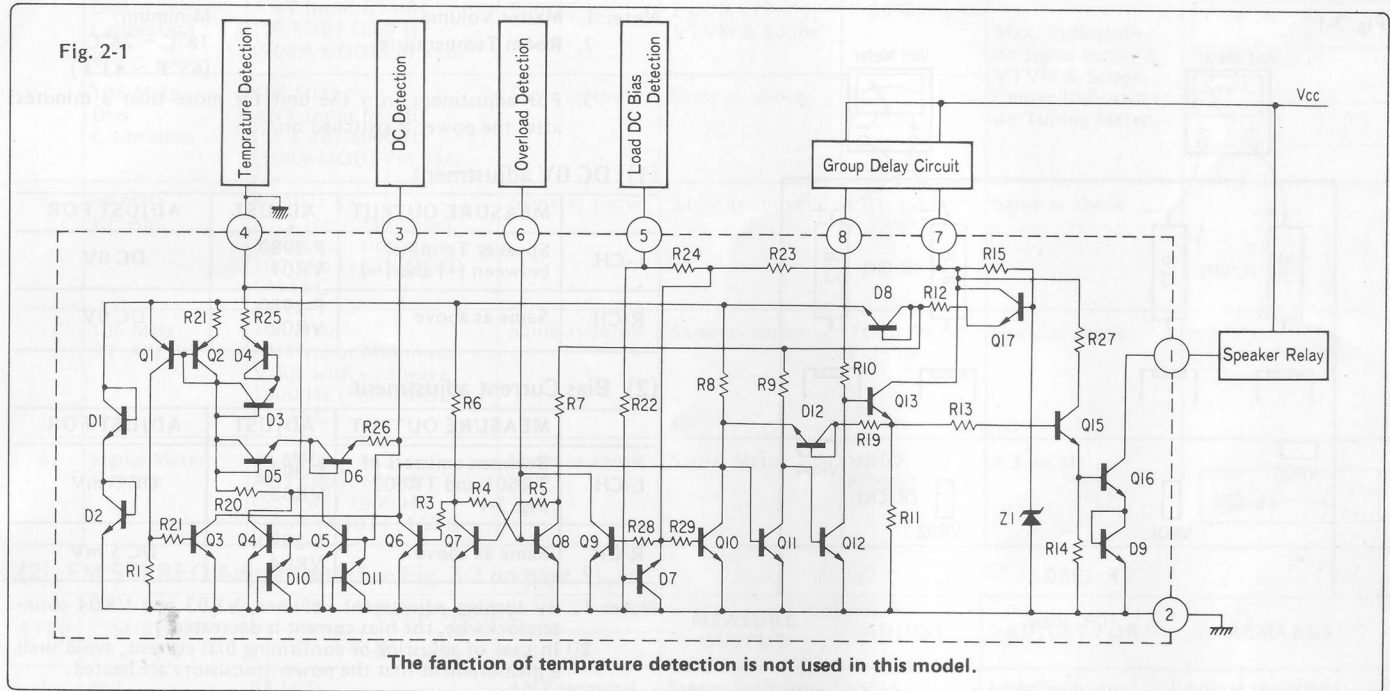

#### Protector circuit with IC, HA-12002 (See Fig. 2-1, 2-2)

This protector IC provides the input terminals for detecting  $\pm$ DC voltage, overload, temperature rise, and pop-noise occurred at switching the power, and output terminal for switching the speaker relay. By the function above, when there are any disorder with amplifier, the output is immediately separated from speaker.

##### \* Prevention against pop-noise at switching the power.

Since the relay RL601 remains OFF for a certain period by the time constant of R611 and C624 when power switch is turned ON, the pop-noise can be eliminated. When turning OFF the power switch, the voltage drop of pin No. 5 is faster than that of Pin No. 7, 8, therefore, the speaker relay turns OFF as soon as power is switched OFF. Resultly, the pop-noise occurred at switching the power OFF is eliminated.

##### \* $\pm$ DC voltage detection

When DC voltage over +1.6V and under -1.86V are applied to pin No. 3 to be its voltage detected by R01, R02, and C626, the speaker relay is turned OFF.

##### \* Detection against overload

When speaker terminal of amplifier is shorted or over loaded, the excessive current flows into emitter resistor R71 of power transistor and makes TR19 ON and if the DC voltage of pin No. 6 rises over +1.4V by above phenomenon, the relay is turned OFF. The relay is kept OFF in spite of the DC voltage being dropped. In order to reset the relay, it is necessary to turn the power switch OFF.

##### \* Detection against temperature rise

As this function is not used in this model, pin No. 4 is grounded.

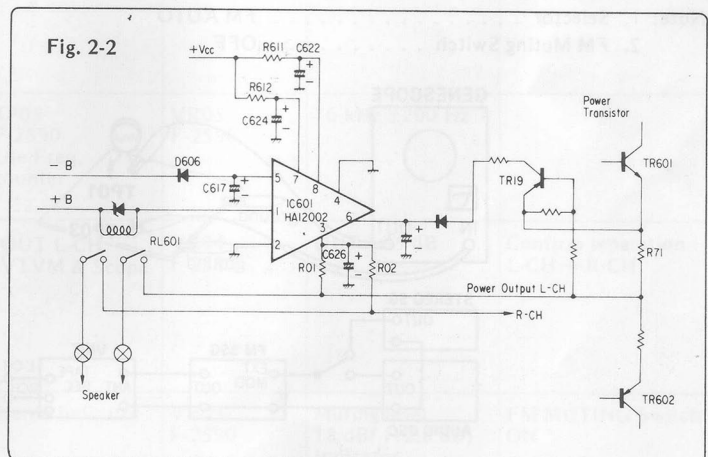

### 3. ADJUSTMENTS

#### 3-1. Driver Circuit Board Adjustments (See Fig. 3-1)

Fig. 3-1

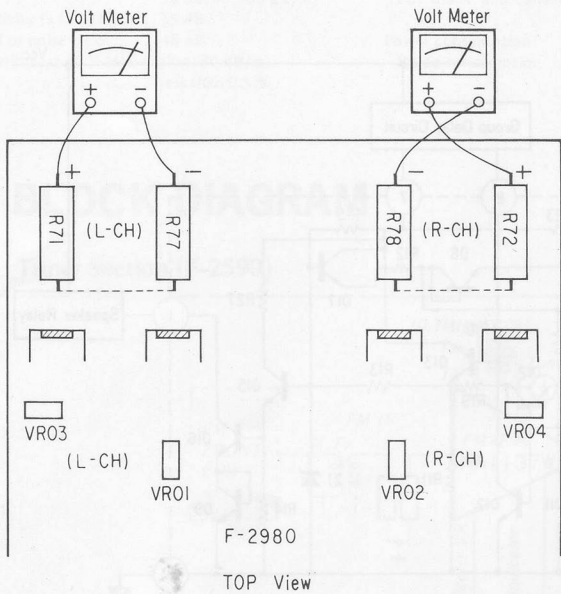

- Note: 1. Master Volume . . . . . Minimum  
 2. Room Temperature . . . . . 18°C ~ 28°C  
 (65°F ~ 83°F)  
 3. For adjustment, run the unit for more than 3 minutes after the power is switched on.

#### (1) DC 0V adjustment

	MEASURE OUTPUT	ADJUST	ADJUST FOR
L-CH	Speaker Terminal between (+) and (-)	F-2980 VR01	DC 0V
R-CH	Same as above	F-2980 VR02	DC 0V

#### (2) Bias Current adjustment

	MEASURE OUTPUT	ADJUST	ADJUST FOR
L-CH	Between emitters of TR601 and TR602 Fig. 3-1	F-2980 VR03	DC 5 mV
R-CH	Same as above	F-2980 VR04	DC 5 mV

- Note: 1. By turning adjustment volumes, VR03 and VR04 counterclockwise, the bias current is decreased.  
 2. In case of adjusting or confirming bias current, avoid such a measurement that the power transistors are heated.

#### 3-2. FM Adjustment

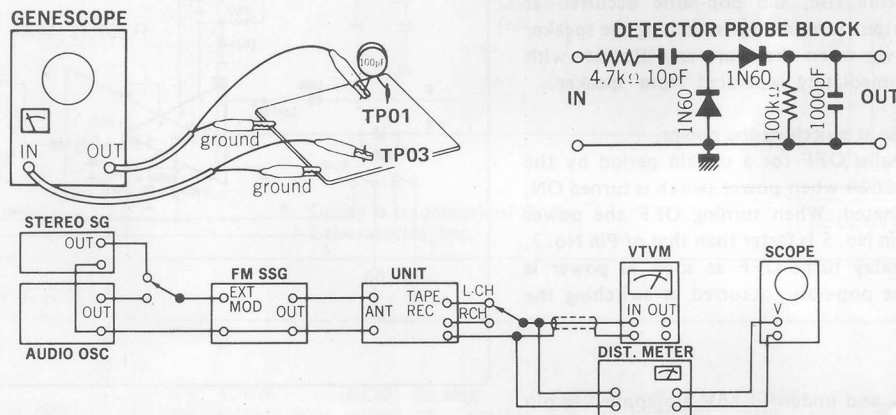

- Note: 1. Selector . . . . . FM AUTO  
 2. FM Muting Switch . . . . . OFF

3. Connection . . . . . Connect the output of genescope to TP01 through 100 pF ceramic capacitor.

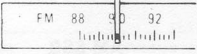
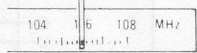

#### (1) FM IF, RF Adjustment and Dial Calibration (See Fig. 3-2 on page 5)

STEP	SUBJECT	FEED SIGNAL		MEASURE OUTPUT	ADJUST	ADJUST FOR	REMARKS
		FROM	TO				
1.	IF Coil	Output 80 dB Genescope	TP01 F-2590	TP03 (Use Detector Probe)	T01 F-2590	Max. IF waveform	
2.	Discriminator Coil	Same as above	Same as above	TP04 F-2590	T02 T03 F-2590	Steep linearity of S curve Make symmetrical S curve	
	Discriminator Coil in case of using Dist Meter	90 MHz ANT Input 65 dBf (59.8 dB) 1000 Hz (100% MOD) FM SSG	ANT terminal 300Ω	OUT L or R-CH Dist Meter	T02 T03 F-2590	Minimum THD	
3.	Tuning Meter	Same as above	Same as above	Tuning Meter	T02 F-2590	Center on Meter	

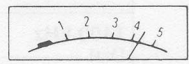
STEP	SUBJECT	FEED SIGNAL		MEASURE OUTPUT	ADJUST	ADJUST FOR	REMARKS
		FROM	TO				
4.	90 MHz Dial Calibration	90 MHz ANT Input 65 dBf (59.8 dB) 1000 Hz (100% MOD) FM SSG	ANT Terminal 300Ω	OUT L or R-CH VTVM & Scope	L03 F-2590	Max. Indication on signal meter & VTVM & Scope. Center Indication on Tuning Meter	
	106 MHz Dial Calibration	106 MHz ANT Input 65 dBf (59.8 dB) 1000 Hz (100% MOD) FM SSG	Same as above	Same as above	TC03 F-2590		
5.	90 MHz RF Adj.	90 MHz ANT Input Minimum Value with sine wave 1000 Hz (100% MOD) FM SSG	Same as above	Same as above	L01, L02 F-2590	Same as above	
	106 MHz RF Adj.	106 MHz ANT Input Minimum Value with sine wave 1000 Hz (100% MOD) FM SSG	Same as above	Same as above	TC01, TC02 F-2590	Same as above	
6.	Signal Meter Volume	98 MHz ANT Input 65 dBf (59.8 dB) 1000 Hz (100% MOD) FM SSG	Same as above	Signal Meter	VR02 F-2590	4.3 on Meter	

(2) FM STEREO Adjustment (See Fig. 3-2 on page 5)

STEP	SUBJECT	FEED SIGNAL		MEASURE OUTPUT	ADJUST	ADJUST FOR	REMARKS
		FROM	TO				
1.	PLL VCO Adj.	98 MHz ANT Input 65 dBf (59.8 dB) FM SSG Pilot 19 kHz (9% MOD) SUB 1 kHz + Pilot (100% MOD) STEREO SG	ANT terminal 300Ω	Stereo indicator	VR05 F-2590	Light indicator	Adjust the VR05 within center of lighting level
	PLL VCO Adj. In case of using Freq. counter.	98 MHz ANT Input 65 dBf (59.8 dB) FM SSG (no MOD)	Same as above	TP05 F-2590 Use Freq. counter	VR05 F-2590	76 kHz ± 200 Hz	
2.	Separation	98 MHz ANT Input 65 dBf (59.8 dB) FM SSG Pilot 19 kHz (9% MOD) R Mode 1 kHz + Pilot (100% MOD) STEREO SG	Same as above	OUT L-CH VTVM & Scope	VR04 F-2590	OUT -35 dB	Confirm separation L-CH → R-CH
3.	Muting level & indicator level	98 MHz ANT Input 18 dBf (12.8 dB) FM SSG Pilot 19 kHz (9% MOD) SUB 1 kHz + Pilot (100% MOD) STEREO SG	Same as above	Stereo indicator	VR03 F-2590	Muting level 18 dBf (12.8 dB) Indicator lighting level 18 dBf (12.8 dB)	FM MUTING Switch ON

●NEW MEASUREMENT FOR FM.

Input signal level under the provision of IHFM-T-200, a new measurement method is indicated by available power ratio "dBf". To obtain approximate available power ratio "dBf", abstract 0.8 from attenuator indication of general FMSSG (open load indication type); however, the former measurement, IHFM-T-100 is designated together too.

The way of modulation on IHFM-T-200 is shown below.

	modulation frequency	modulation mode	modulation factor
FM MONO	1000 Hz		100%
FM STEREO	1000 Hz	SUB	Pilot 9% Pilot + SUB 100%

- The relation between the standard input 65 dBf of IHFM-T-200 and the former indication "dB" is shown below.

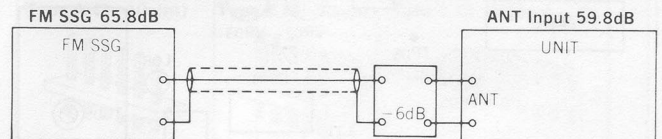

3-3. AM IF, RF Adjustment and Dial Calibration (See Fig. 3-2 below)

- Note: 1. Selector . . . . . AM  
 2. Confirm start point of dial pointer before alignment.

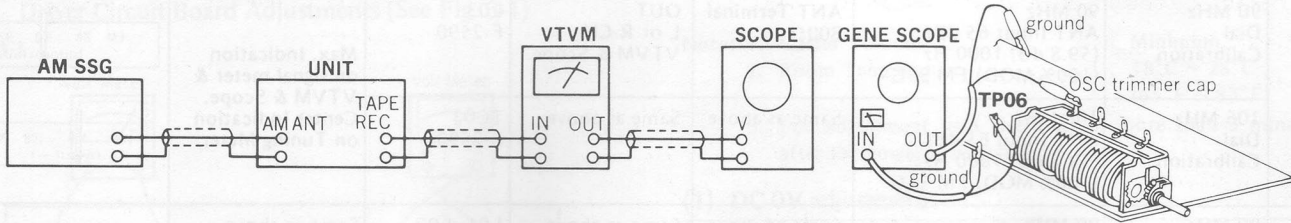

STEP	SUBJECT	FEED SIGNAL		MEASURE OUTPUT	ADJUST	ADJUST FOR	REMARKS
		FROM	TO				
1.	IF Coil	Genescope Output 45 dB	TC04 F-2590	TP06 F-2590	CF04 F-2590	Max. IF waveform	
2.	600 kHz Dial Calibration	600 kHz ANT Input 60 dB 400 Hz (MOD 30%) AM SSG	AM ANT terminal	REC OUT L or R-CH VTVM & Scope	T04 F-2590	Max. Output	
	1400 kHz Dial Calibration	1400 kHz ANT Input 60 dB 400 Hz (MOD 30%) AM SSG	Same as above	Same as above	TC05 F-2590	Same as above	
3.	600 kHz RF Adj.	600 kHz ANT Input 60 dB 400 Hz (MOD 30%) AM SSG	Same as above	Same as above	L702 Bar Antenna	Same as above	
	1400 kHz RF Adj.	1400 kHz ANT Input 60 dB 400 Hz (MOD 30%) AM SSG	Same as above	Same as above	TC04 F-2590	Same as above	
4.	Signal Meter volume	1000 kHz ANT Input 54 dB 400 Hz (MOD 30%) AM SSG	Same as above	Signal Meter	VR06 F-2590	4 on meter	

•Adjusting or Connecting Points on AM, FM & FM MPX circuit board, F-2590

Fig. 3-2

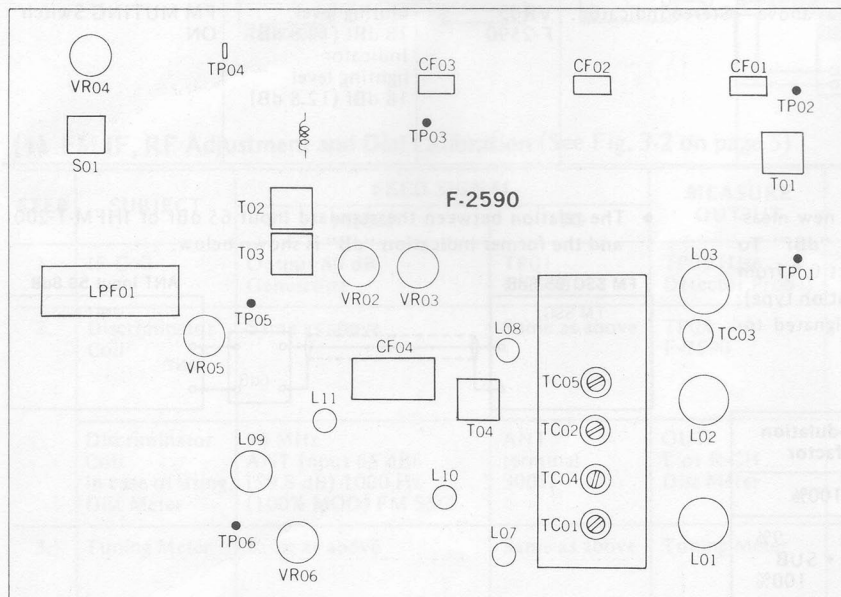

•Abbreviations

- Equipment**  
 AM FM Generator Oscilloscope . . . Genescope  
 AM Standard Signal Generator . . . AM SSG  
 FM Standard Signal Generator . . . FM SSG  
 FM Stereo Generator . . . . . Stereo SG  
 Oscilloscope . . . . . Scope  
 Audio Oscillator . . . . . Audio Osc.

- Others**  
 Antenna . . . . . ANT.  
 Modulation . . . . . MOD.  
 Total Harmonic Distortion . . . . . T.H.D.

# 4. PARTS LOCATION & PARTS LIST

## 4-1. F-2865 Equalizer Circuit Board (Stock No. 7551411)

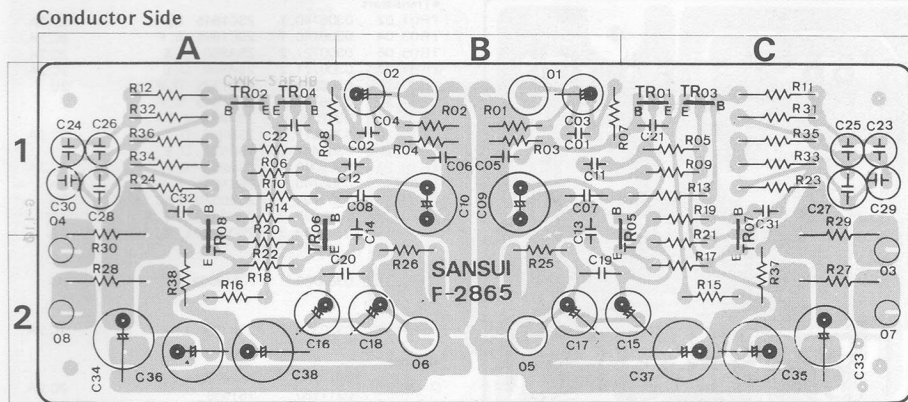

### Parts List

Parts No.	Stock No.	Description	Position
●Transistors			
TR01, 02	0300900, 1	2SA906 G, H	1C.A
TR03, 04	0300900, 1	2SA906 G, H	1C.A
TR05, 06	0306740, 1	2SC1845 E, F	1B.A
TR07, 08	0306740, 1	2SC1845 E, F	
C			
05, 06	0620101	100pF 50V P.C.	1B
23, 24	0625122	1200pF 50V P.C.	1C.A
25, 26	0620391	390pF 50V P.C.	1C.A
27, 28	0625562	5600pF 50V P.C.	1C.A
29, 30	0620101	100pF 50V P.C.	1C.A
R			
11, 12	0231101	100Ω 1/2W M.R.	1C.A
13, 14	0231102	1kΩ 1/2W M.R.	1C.A
23, 24	0200332	3.3kΩ 1/2W N.I.R.	1C.A
28	0200270	27Ω 1/2W N.I.R.	2C.A
30	0200270	27Ω 1/2W N.I.R.	1C.A
31, 32	0231473	47kΩ 1/2W M.R.	1C.A
33, 34	0231223	22kΩ 1/2W M.R.	1C.A
35, 36	0231564	560kΩ 1/2W M.R.	1C.A
	2410590	4P Pin Ass'y Type D	

## 4-2. F-2863 Tone Control Circuit Board (Stock No. 7562741)

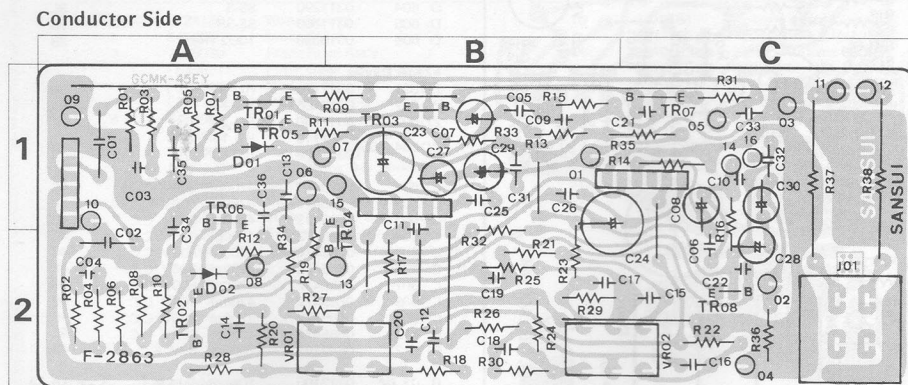

### Parts List

Parts No.	Stock No.	Description	Position
●Transistors			
TR01, 02	0306740, 1	2SC1845 E, F	1, 2A
TR03, 04	0306740, 1	2SC1845 E, F	1, 2B
TR05, 06	0306070, 1	2SC1313 F, G	1A
TR07, 08	0300470, 1	2SA726 F, G	1, 2C
●Varistor			
D 01, 02	0340120	VD1212	1, 2A
	0340150	MV-12	
R 37, 38	0135221	220Ω 5W Ce.R.	1C
VR01, 02	1015360, 1	100kΩ (C) x 2, Bass & Treble Volume	2B
J 601	2430400	Jack, headphone	

## 4-3. F-2916 Mic Amp Circuit Board (Stock No. 7610421)

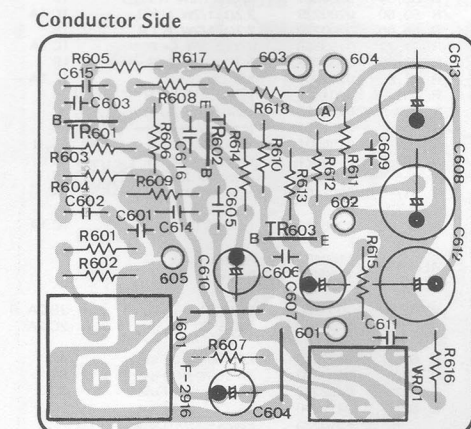

### Parts List

Parts No.	Stock No.	Description
●Transistors		
TR601	0306070, 1	2SC1313 F, G
TR602	0300471	2SA726 (W) F, G
TR603	0306070	2SC1313 F
VR601	1090270, 1	20kΩ (A) Mic Mixing Volume
J 601	2430400	Mic Jack

### ●Connector & Pin Ass'y

#### Connectors

Type A (3~10pins)

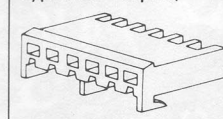

Type B (2~6pins)

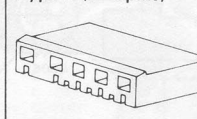

Stock No.
2420450
2420460
2420650
2420470
2420480
2420490

NOTE: Since stock number of female connectors (type B) with wires are not shown in each parts list of Complete circuit board, please refer to the above parts list when ordering the connector.

#### Pin Ass'y

Type A (3~10pins)

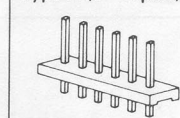

Type B (3~10pins)

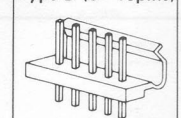

Type C (3~10pins)

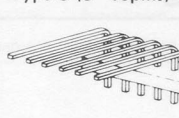

Type D (2~6pins)

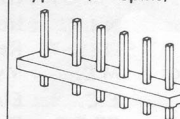

Type E (2~6pins)

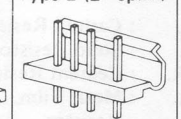

Type F (2~6pins)

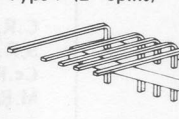

4-4. F-2980 Power Amplifier Circuit Board (Stock No. 7572171)

Conductor Side

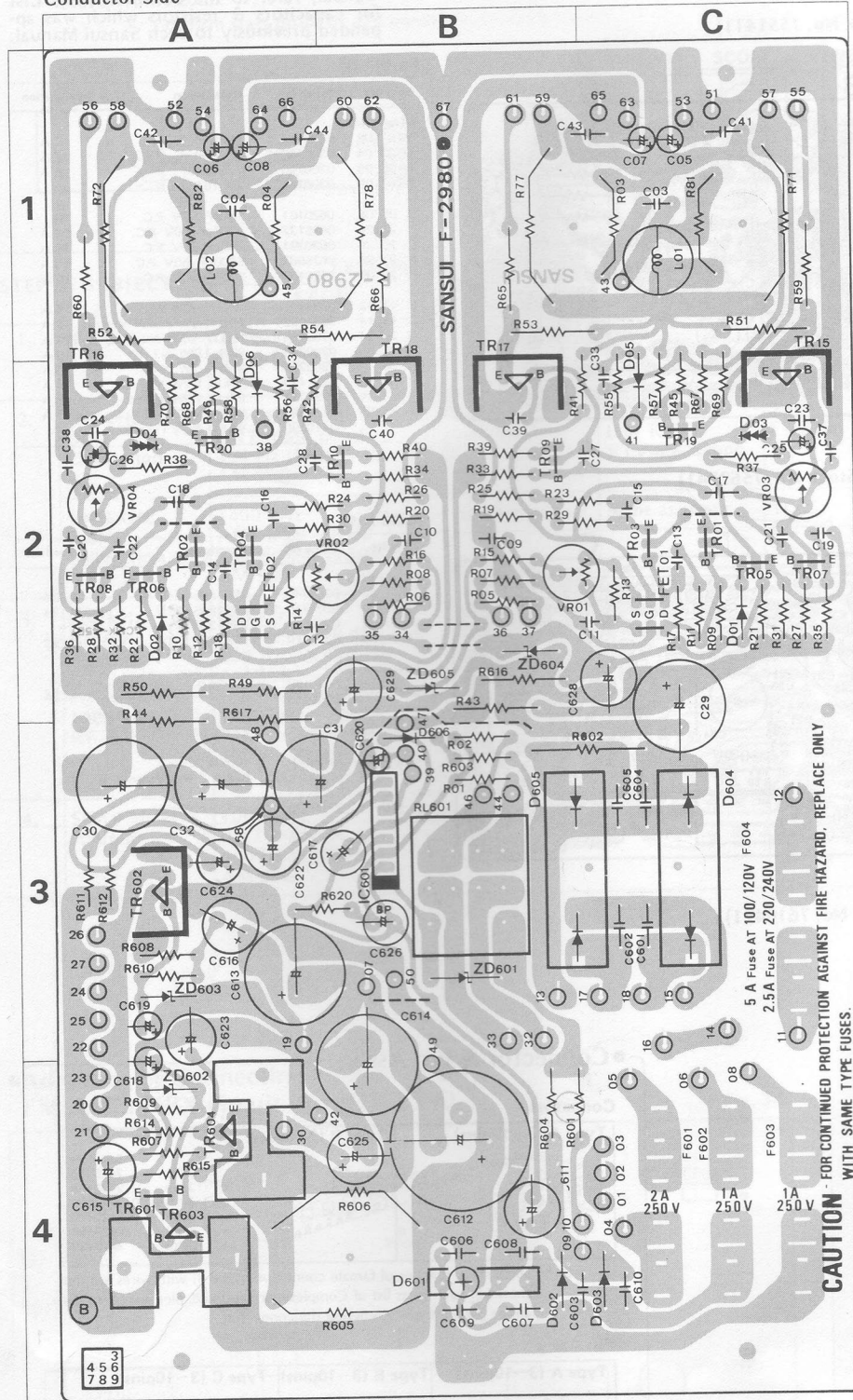

Parts List

Part No.	Stock No.	Description	Position
<b>•Transistors</b>			
TR01, 02	0306740, 1	2SC1845 E, F	2C, 2A
TR03, 04	0306740, 1	2SC1845 E, F	2C, 2A
TR05, 06	0300721, 2	2SA850 D, E	2C, 2A
TR07, 08	0300721, 2	2SA850 D, E	2C, 2A
TR09, 10	0306281, 2	2SC1735 D, E	2B
TR11, 12	0306740, 1	2SC1845 E, F	
TR13, 14	0301090, 1	2SA992 E, F	2C, 2A
TR15, 16	0308611, 2	2SD357 D, E	2B
TR17, 18	0303441, 2	2SB527 D, E	2C, 2A
TR19, 20	0301090, 1	2SA992 E, F	4A
TR601	0306740, 1	2SC1845 E, F	3A
TR602	0303232, 3	2SB507V11-AL E, F	4A
TR603	0308392, 3	2SD313AL E, F	4A
TR604	0308392, 3	2SD313AL E, F	4A
<b>•IC</b>			
IC 601	0360900	HA12002	3B
<b>•FET</b>			
FET01, 02	0370311, 2	2SK129 L, M	2C, 2A
<b>•Diodes</b>			
D 01, 02	{0311160 0311180	1S2473D 1S1588	2C, 2A
D 05, 06	{0311160 0311180	1S2473D 1S1588	2C, 2A
D 601	0311700	RB-152	4B
D 602	0310350	10D2 (Red)	4B
D 603	0310350	10D2 (Red)	4C
D 604	0311290	SS-3	3C
D 605	0311300	SS-3R	3B
D 606	0310350	10D2 (Red)	3B
<b>•Zener Diodes</b>			
ZD601	0317170	RD 24F (B)	3B
ZD602	0317180	RD 24F (C)	4A
ZD603	0317180	RD 24F (C)	3A
ZD604, 605	{0317110 0317120	RD-18F (B) RD-18F (C)	2B
C 601	0655472	4700pF 500V C.C.	4C
C 602	0655472	4700pF 500V C.C.	4C
C 603	0655472	4700pF 500V C.C.	4C
C 604	0655472	4700pF 500V C.C.	4C
C 605	0655472	4700pF 500V C.C.	4C
C 606	0655472	4700pF 500V C.C.	4B
C 607	0655472	4700pF 500V C.C.	4B
C 608	0655472	4700pF 500V C.C.	4B
C 609	0655472	4700pF 500V C.C.	4B
C 610	0655472	4700pF 500V C.C.	4C
C 612	0549207	1000µF 63V E.C.	4B
R 03, 04	0212100	10Ω 2W N.I.R.	1A, 1A
R 37, 38	0200100	10Ω 1/2W N.I.R.	2C, 2A
R 43, 44	0200221	220Ω 1/2W N.I.R.	2B, 2A
R 49, 50	0200221	220Ω 1/2W N.I.R.	2A
R 51, 52	0200221	220Ω 1/2W N.I.R.	1C, 1A
R 53, 54	0200221	220Ω 1/2W N.I.R.	1B
R 59, 60	0200229	2.2Ω 1/2W N.I.R.	1C, 1A
R 65, 66	0200229	2.2Ω 1/2W N.I.R.	1B
R 71, 72	0153338	0.33Ω 3W Ce.R.	1B
R 77, 78	0153338	0.33Ω 3W Ce.R.	1C, 1A
R 81, 82	0212109	1Ω 2W N.I.R.	4B
R 601	0201122	1.2kΩ 1W N.I.R.	3C
R 602	0212822	8.2kΩ 2W N.I.R.	4B
R 604	0201102	1kΩ 1W N.I.R.	4A, B
R 605	0185391	390Ω 5W N.I.R.	4B
R 606	0185471	470Ω 5W N.I.R.	2B
R 616	0201102	1kΩ 1W N.I.R.	2A
R 617	0201102	1kΩ 1W N.I.R.	2A
L 01, 02	4290370	1µH RF Coil	1C, 1A
RL601	{1150400 1150480	Relay Relay	2B, 2A, B 2C, 2A
VR01, 02	1034150	100Ω B	2B, 2A, B
VR03, 04	1034150	100Ω B	2C, 2A
F 601	0432240	2A 250V AC Fuse	4C
F 602	0432220	1A 250V AC Fuse	4C
F 603	0432220	1A 250V AC Fuse	4C
F 604	0432290	5A 125V AC Fuse	3C
	2310220	Fuse Holder (Large)	
	2310230	Fuse Holder (Small)	

Abbreviations

C.R.	: Carbon Resistor	N.I.R.	: Non-Inflammable Resistor	C.C.	: Ceramic Capacitor
S.R.	: Solid Resistor	M.C.	: Mylar Capacitor	Mi.C.	: Mica Capacitor
Ce.R.	: Cement Resistor	E.C.	: Electrolytic Capacitor	O.C.	: Oil Capacitor
M.R.	: Metal Film Resistor	BP.E.C.	: Bi-Polar Electrolytic Capacitor	P.C.	: Polystyrene Capacitor
F.R.	: Fusing Resistor			T.C.	: Tantalum Capacitor



- The circuit boards, F-2862, F-2878, F-2879, F-2866, F-2864, F-2868, F-2981, F-2867 & F-2854 are not supplied as the assembled, the individual parts on the circuit boards, however, are provided for orders.

### 4-6. F-2862 Power Indicator Circuit Board

#### Parts List

Parts No.	Stock No.	Description
LD601	0319050	LED (Green) power

### 4-7. F-2862 FM Stereo Indicator Circuit Board

#### Parts List

Parts No.	Stock No.	Description
LD601	0319060	LED (Red) FM stereo

### 4-8. F-2878 Balance Volume Circuit Board

#### Parts List

Parts No.	Stock No.	Description
VR01	1015320, 1	250kΩ (M, N) x 2 Balance Volume

### 4-9. F-2879 Volume Circuit Board

#### Parts List

Parts No.	Stock No.	Description
VR01	1011160, 1	150kΩ (B) x 2 Volume

### 4-10. F-2866 Tape Monitor/FM Muting & Mode Switch Circuit Board

#### Conductor Side

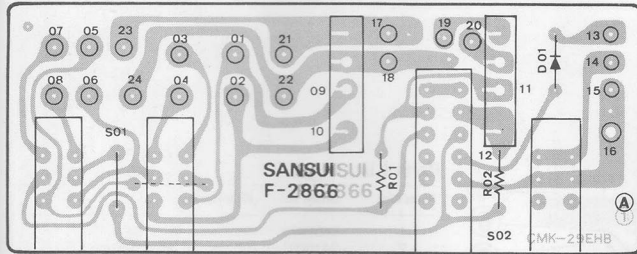

#### Parts List

Parts No.	Stock No.	Description
●Diode		
D 601	{0311160 0311180}	1S2473D 1S1588
S 01	1131560, 1	Tape Monitor SW
S 02	1131590 2410590	FM Muting & Mode SW 4P Pin Ass'y Type D

### 4-11. F-2864 Input Terminal Circuit Board

#### Conductor Side

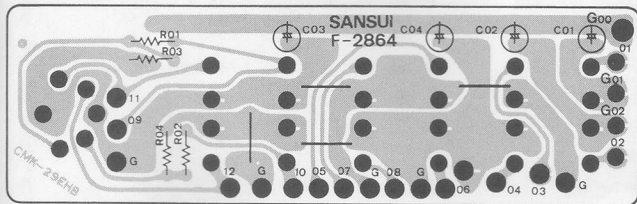

#### Parts List

Parts No.	Stock No.	Description
	2090030	5P Din Socket
	2200490	12P Input Terminal

### 4-12. F-2868 Speakers Selector Circuit Board

#### Parts List

Parts No.	Stock No.	Description
S 01	1131580, 1	Speaker Selector SW

### 4-13. F-2981 Power Transistor Circuit Board (L-CH)

#### Parts List

Parts No.	Stock No.	Description
●Transistors		
TR601	0306780, 1	2SC2578LB O, Y
TR602	0301130, 1	2SA1103LB O, Y
●Diode		
D 601	0340161, 2	STV-3H G, Y

### 4-14. F-2981 Power Transistor Circuit Board (R-CH)

#### Conductor Side

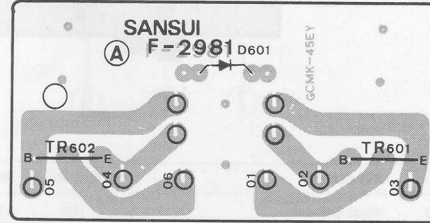

#### Parts List

Parts No.	Stock No.	Description
●Transistors		
TR601	0301130, 1	2SA1103LB O, Y
TR602	0306780, 1	2SC2578LB O, Y
●Varistor		
D 601	0340161, 2	STV-3H G, Y

### 4-15. F-2867 Tone & Subsonic Filter Switch Circuit Board

#### Conductor Side

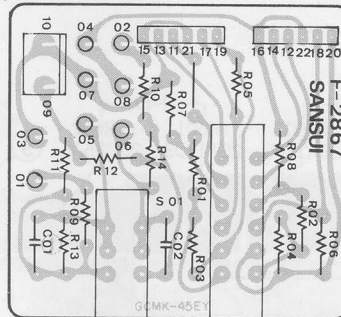

#### Parts List

Parts No.	Stock No.	Description
S 01	1131570, 1	Tone & Subsonic Filter SW

### 4-16. F-2854 Audio Muting & Loudness Switch Circuit Board

#### Conductor Side

#### Loudness Switch Circuit Board

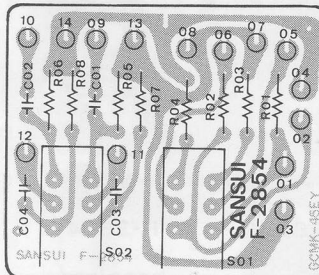

#### Parts List

Parts No.	Stock No.	Description
C 01, 02	0620511	510pF 50V P.C.
S 01	1131560, 1	Audio Muting & Loudness SW

# 5. OTHER PARTS

## 5-1. Front View

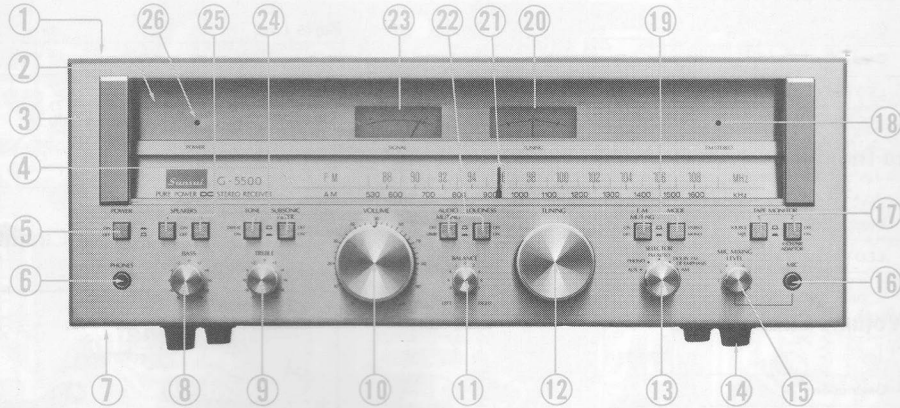

### Parts List

Parts No.	Stock No.	Description	Parts No.	Stock No.	Description	Parts No.	Stock No.	Description
1	5727160	Wood Bonnet	10	5319181	Volume Knob	18	0319060	FM Stereo LED (Red)
2	5456580	Inside Panel	1011160, 1	5319133	150kΩ (B) x 2 Volume Balance Volume Knob	19	5326690	FM Muting & Mode Switch Knob
3	7008080	Front Panel Ass'y	5319133	1015320, 1	250kΩ (M, N) x 2 Balance Volume Tuning Knob	20	1131590, 1	FM Muting & Mode Switch
	5408311	Front Glass	5319172	5319142	Selector Switch Knob	21	4301240, 1	Tuning Meter
	5048121	Masking Plate	1103600, 1	5319133	Selector Switch	22	7116090	Dial Pointer
	5517270	Masking Packing	14	5516821	Lag	23	5326690	Audio Muting & Loudness Switch Knob
4	5408580	Dial Scale	15	5319133	Mic Mixing Level Volume Knob	24	1131560, 1	Audio Muting & Loudness Switch
5	5326690	Power Switch Knob	1090270, 1	2430400	20kΩ (A) Mic Mixing Level Volume Microphone Jack Socket	23	4301230, 1	Signal Meter
5	1131650	Power Switch	16	5326690	Tape Monitor Switch Knob	24	5326690	Tone & Subsonic Filter Switch Knob
6	2430400	Head Phone Jack Socket	17	1131560, 1	Tape Monitor Switch	25	1131571	Tone & Subsonic Filter Switch
7	5058861	Bottom Plate				26	0319050	Speaker Selector Knob
8	5319081	Bass Volume Knob						Speaker Selector Switch
8	1015360, 1	100kΩ (C) x 2 Bass Volume						Power LED (Green)
9	5319081	Treble Volume Knob						
9	1015360, 1	100kΩ (C) x 2 Treble Volume						

## 5-2. Top View

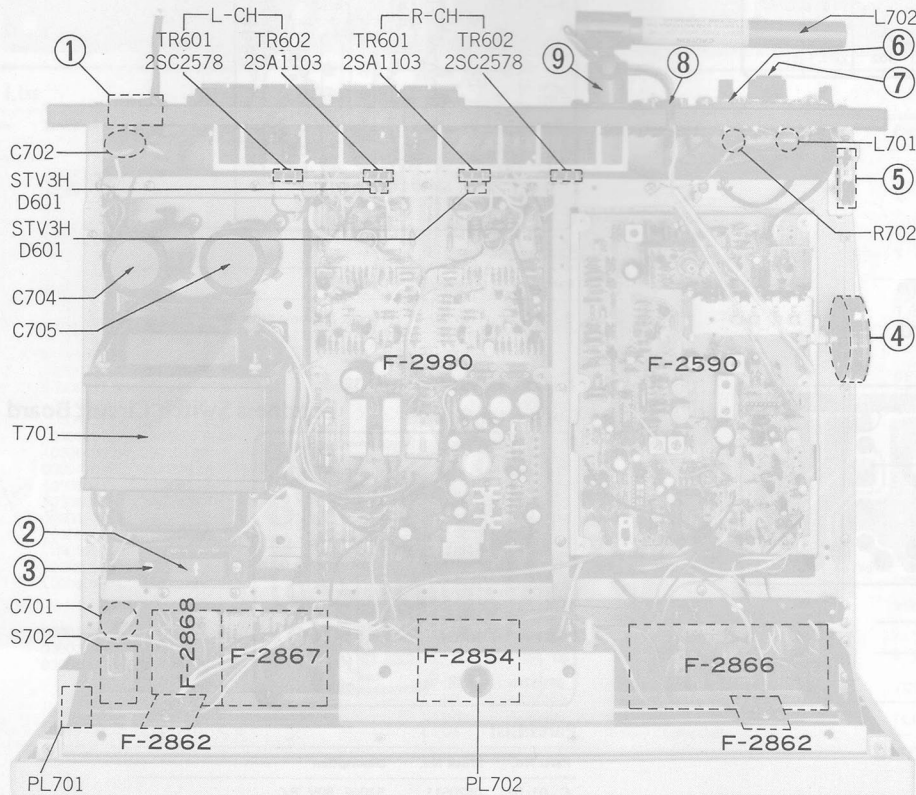

### Parts List

Parts No.	Stock No.	Description
1	2450070	AC Outlet
2	2410091	6P Voltage Selector Plug
3	2410830	10P Voltage Selector Socket
4	6146670	Pulley
5	7136083	Tension Unit
6	2210310	Antenna Terminal Board
7	5286480	Bar Antenna Holder (B)
8	3910490	Strain Relief (Antenna Cord)
9	5286450	Bar Antenna Holder
● Transistors		
TR 601 (L-CH)	0306780, 1	2SC2578LB O, Y
TR 601 (R-CH)	0301130, 1	2SA1103LB O, Y
TR 602 (L-CH)	0301130, 1	2SA1103LB O, Y
TR 602 (R-CH)	0306780, 1	2SC2578LB O, Y
● Diode		
D 601	0340161, 2	STV-3H G, Y
C 701	0605337	0.033μF 250V M.C.
C 702	0659802	0.0047μF 150V C.C.
C 704	0559384	10000μF 50V E.C.
C 705	0559384	10000μF 50V E.C.
R 702	0103122	1.2kΩ 1/2W C.R.
L 701	4290021	Balun
L 702	4200830, 1	Bar Antenna
T 701	4002930	Power Transformer
S 702	1131650	Power Switch
PL 701, 702	0400650	8V 0.3A Pilot Lamp

5-3. Bottom View

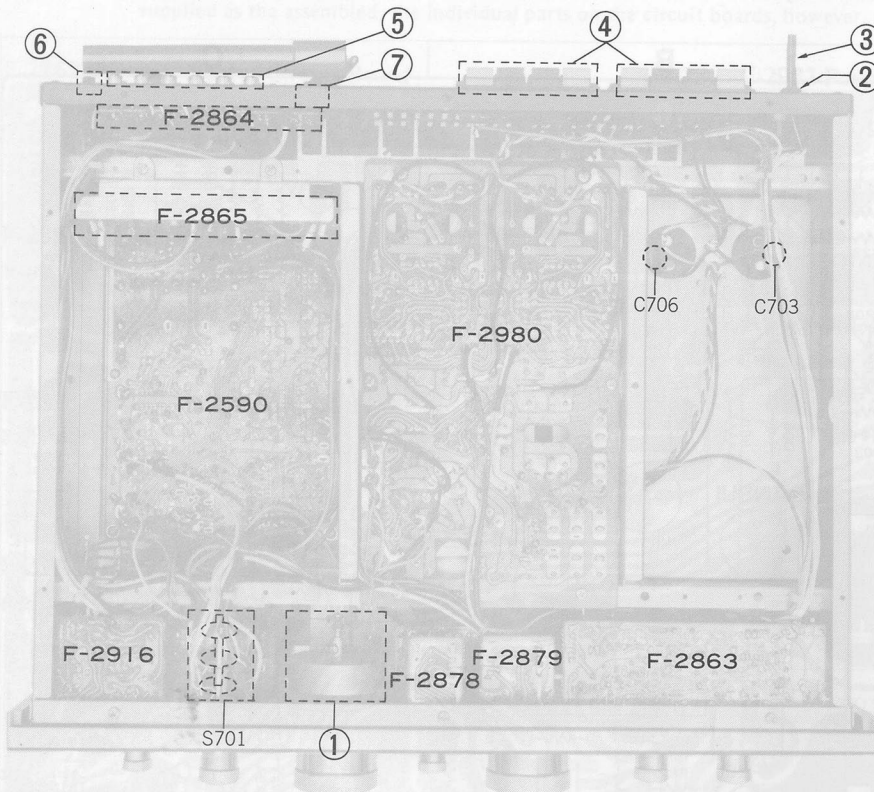

Parts List

Parts No.	Stock No.	Description	Position
1	7036620	Tuning Unit	
2	3910600	Strain Relief (AC Cord)	
3	3800470	AC Cord	
4	2290190	Speaker Terminal	
5	2200490	12P Input Terminal Board	
6	2230150	Ground Terminal	
7	2090030	5P Din Socket	
C 703	0602108	0.1μF 100V M.C.	
C 706	0602108	0.1μF 100V M.C.	
S 701	1103600, 1	Selector Switch	

## 6. THREADING OF DIAL CORD

- If a dial cord is cut off or slips, replace it by following procedures.  
As this unit uses 0.5 mmφ cord, please replace it with the same type certainly.
- The length of dial cord is approximately 170 cm (66.9 inch).

Fig. 6-1

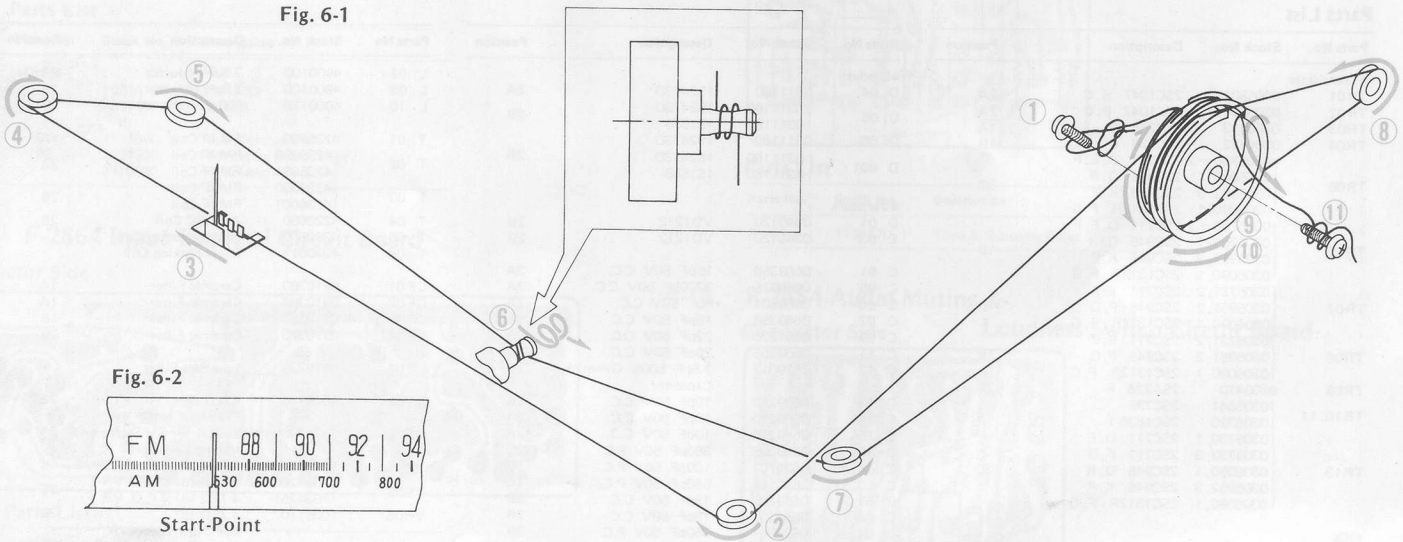
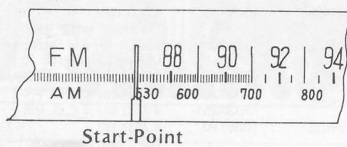

Fig. 6-2



### 1. Threading of Dial Cord

Thread the dial cord in numerical order from 1 to 11 as Fig. 6-1.

- Close the variable capacitor completely.

Stock No.	Description
6036051	Dial Cord (0.5 mmφ)
6146670	Dial Pulley

### 2. Attachment of Dial Pointer

1. Set the dial pointer to the start-point as Fig. 6-2.

- Confirm that the dial pointer runs smoothly on the dial scale by turning the tuning shaft.

# 7. SCHEMATIC DIAGRAM 7-1. Audio & Power Supply Section

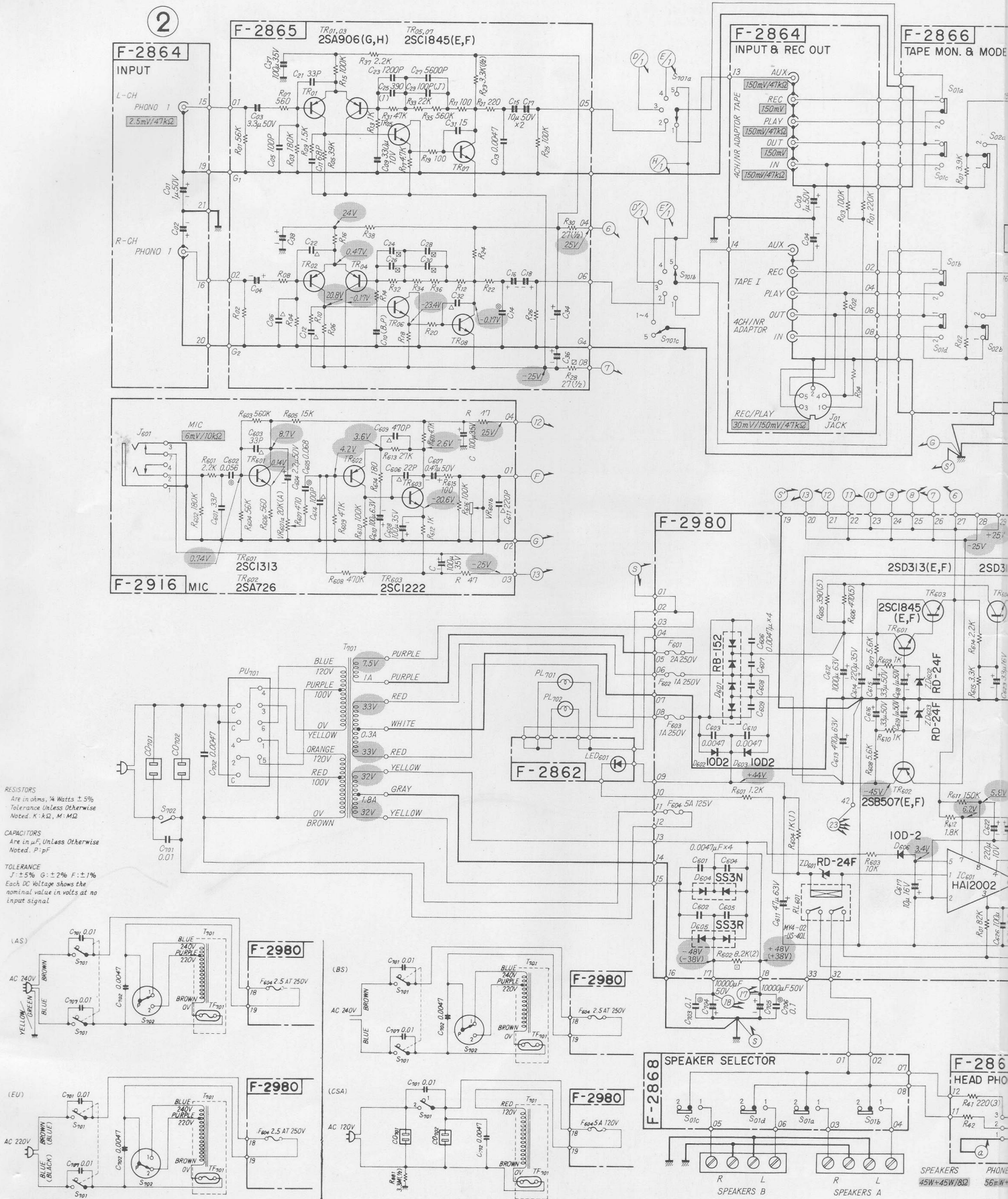

E

F

G

H

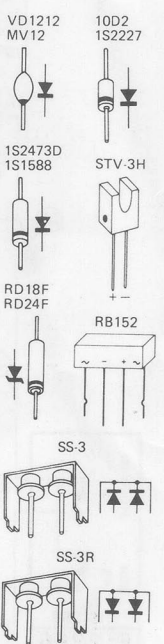
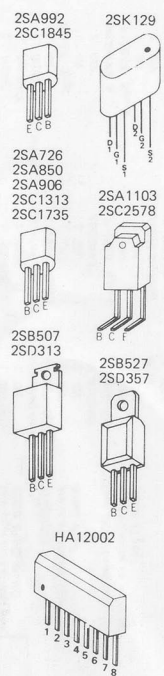
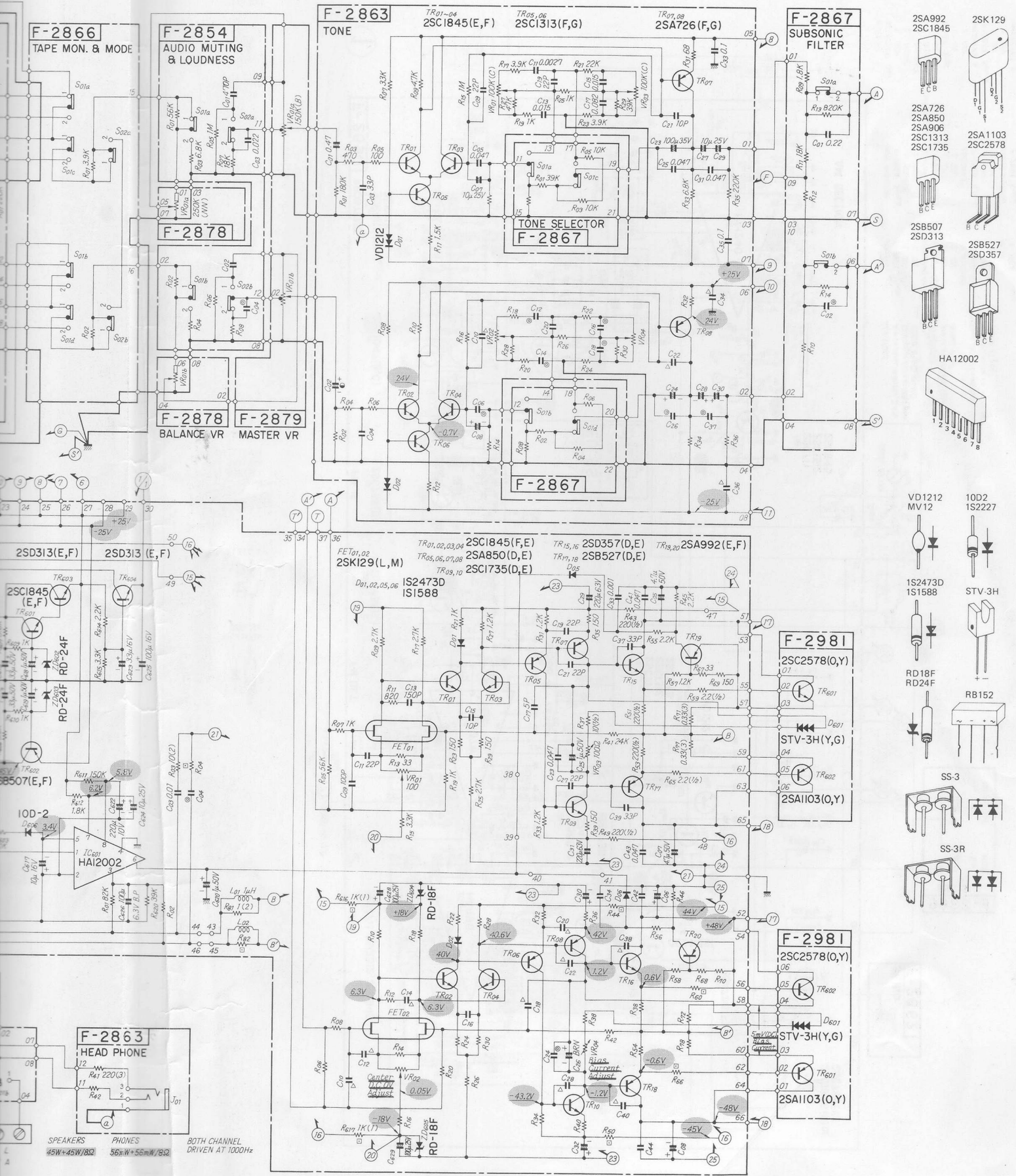

1

2

3

4

5

SPEAKERS PHONES BOTH CHANNEL DRIVEN AT 1000Hz
45W+45W/8Ω 55W+55W/8Ω

Design and specifications subject to change without notice for improvement.  
 • La présentation et les spécifications sont susceptibles d'être modifiées sans préavis par suites d'améliorations éventuelles.  
 • Änderungen, die dem technischen Fortschritt dienen, bleiben vorbehalten.

7-2. Tuner Section

- SWITCHES**
- 1. AUX
  - 2. PHONO
  - 3. FM AUTO
  - 4. ON OFF FM DE-EMPHASIS
  - POWER SENS
  - 2. OFF
  - 1. ON
  - SPEAKERS A
  - F-2868 S<sub>9a,b</sub>
  - 1. ON
  - 2. OFF
  - AUDIO MUTING
  - F-2854 S<sub>9a,b</sub>
  - 1. OFF
  - 2. ON
  - SPEAKERS B
  - F-2868 S<sub>9a,b</sub>
  - 1. ON
  - 2. OFF
- TAPE MONITOR**
- F-2864 S<sub>9a,b</sub>
  - 1. SOURCE
  - 2. ON
  - 4. TAPE ADAPTOR
  - F-2864 S<sub>9a,b</sub>
  - 1. OFF
  - 2. ON
  - 4. TAPE ADAPTOR
  - F-2867 S<sub>9a,b</sub>
  - 1. OFF
  - 2. ON
  - FM MUTING
  - F-2866 S<sub>9i</sub>
  - 1. ON
  - 2. OFF
  - MODE
  - F-2866 S<sub>9a-c</sub>
  - 1. STEREO
  - 2. MONO
- RESISTORS**
- Are in ohms, unless -5% tolerance unless otherwise noted. R-3KΩ, W-1/2W
- CAPACITORS**
- Are in μF unless otherwise noted. P-pF
- Each DC voltage shows the numerical value in volts no input signal.

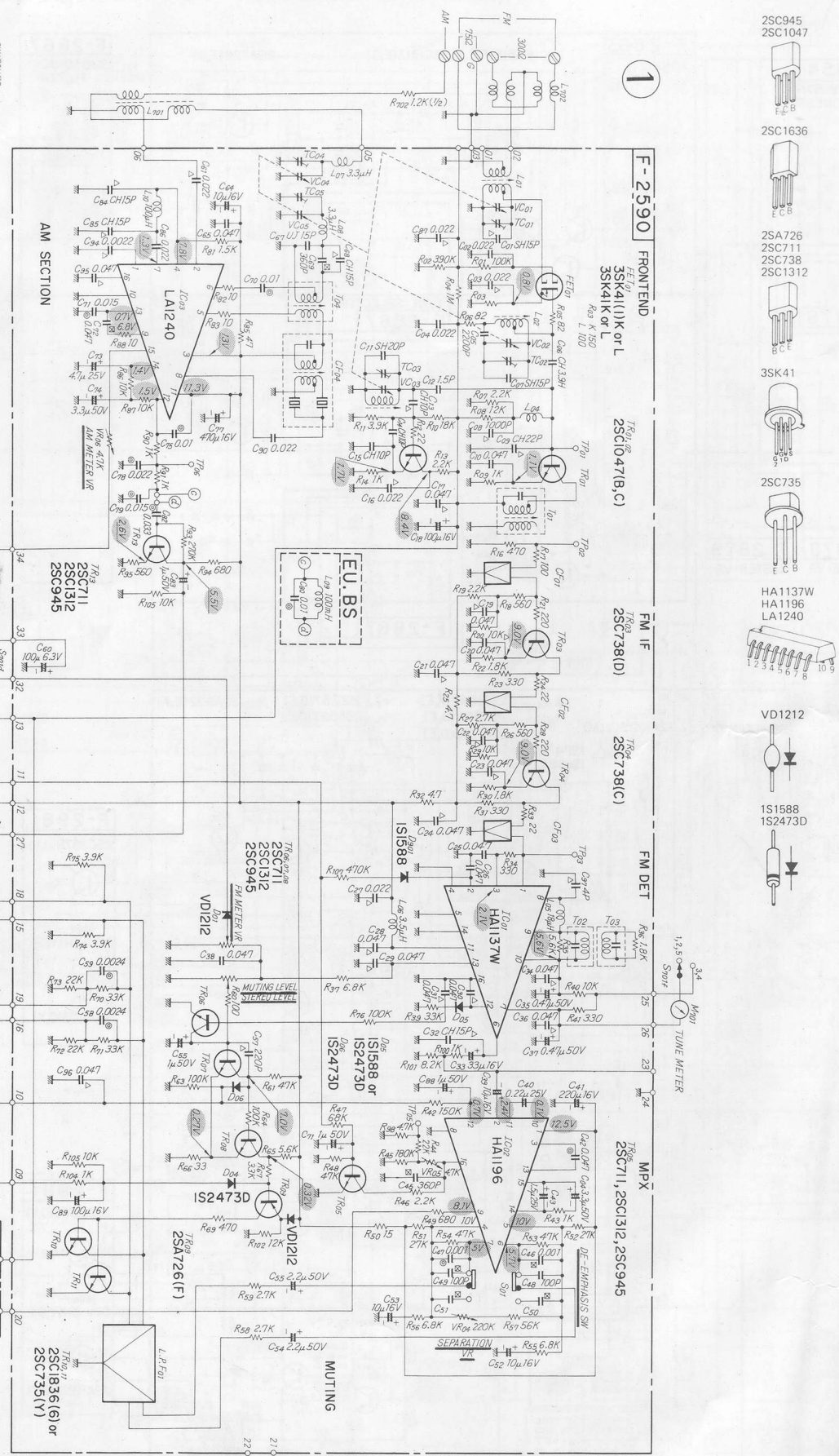

- 1
- 2
- 3
- 4
- 5

- 25C945
- 25C1047
- 25C1636
- 25A726
- 25C711
- 25C738
- 25C1312
- 35K41
- 25C735
- HA1137W
- HA1196
- LA1240
- VD1212
- IS1588
- IS2473D

1

F-2590 FRONT END  
 FE1/F  
 35K41(I)K or L  
 35K41K or L

T801, T802, T803  
 25C1047(B,C)

T804  
 25C738(D)

T805  
 25C738(C)

FM DET

T806  
 25C711, 25C1312, 25C945

MPX

1.25V  
 5.0V  
 12.5V

34  
 300Ω  
 TUNE METER

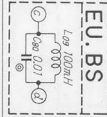

MUTING

T807, T808  
 25C1312, 25C945

ST. IND. LED<sub>9a</sub>

F-2866

IS1588

VD1212

25C711, 25C1312, 25C945

T809  
 25C711, 25C1312, 25C945

LA1240

1.25V  
 5.0V  
 12.5V

## 8. PACKING LIST

Parts No.	Stock No.	Description
1	9116790	Vinyl Cover
2	9028141	Styrofoam Packing (Upper)
3	9028151	Styrofoam Packing (Lower)
4	9001420	Carton Case
5	5996080	CurI Stopper

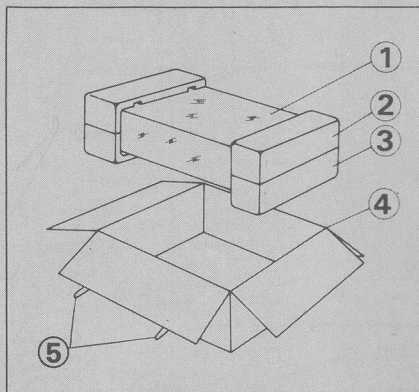

## 9. ACCESSORY PARTS LIST

Stock No.	Description
9204410	Operating Instructions
9237920	Schematic Diagram
3820100	FM Antenna

MEMO



SANSUI ELECTRONICS CORPORATION: 55-11 Queens Blvd. Woodside, N.Y. 11377 U.S.A.  
 333 West Alondra Blvd. Gardena, California 90247 U.S.A.  
 3036 Koapaka St. Honolulu, Hawaii 96819 U.S.A.

SANSUI AUDIO EUROPE N.V.: North Trade Bldg (9th floor) Noorderlaan 133-Bus 1,2030 Antwerp, Belgium  
 SANSUI AUDIO EUROPE S.A.: Arabella center, 6 Frankfurt AM Main, Lyoner Strasse 44-48, West Germany

SANSUI ELECTRIC COMPANY LTD.: 14-1, Izumi 2-chome, Suginamiku, Tokyo 168 Japan PHONE: (03) 323-1111/TELEX:232-2076