

SERVICE MANUAL

INTEGRATED AMPLIFIER

SANSUI AU-D11II

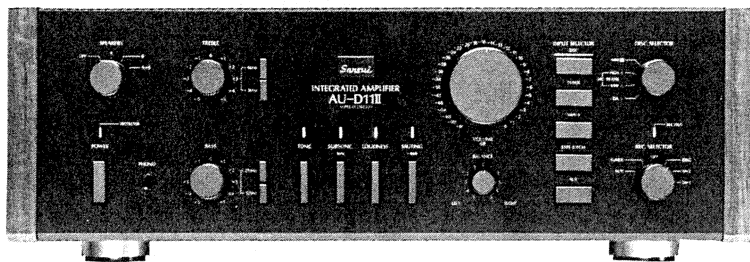

CAUTION

1. Parts identified by the \triangle symbol on the schematic diagram and the parts list are critical for safety. Use only replacement parts that have critical characteristics recommended by the manufacturer.
2. Make leakage-current or resistance measurements to determine that exposed parts are acceptably insulated from the supply circuit before returning the appliance to the customer.

•SPECIFICATIONS

Power output

Min. RMS, both channels driven, from 10 to 20,000 Hz, with no more than 0.0028% total harmonic distortion.

130 watts per channel into 8 ohms.

Load impedance..... 8 ohms

Total harmonic distortion

..... less than 0.0028% at or below rated min. RMS power output

Intermodulation distortion

(60 Hz: 7 kHz = 4:1 SMPTE method)

..... less than 0.0028% at rated power output

Frequency response (at 1 watt)

Overall (from AUX)..... DC to 300,000 Hz, +0 dB
-3.0 dB

RIAA curve deviation (DISC-MM, 20 Hz to 20 kHz)

..... +0.2 dB, -0.2 dB

Input sensitivity and impedance (at 1 kHz)

DISC-MC-HIGH 250 μ V/40 ohms

DISC-MC-LOW 70 μ V/3.2 ohms
(Max. input capability (LOW): 25 mV at 1 kHz, less than 0.01% total harmonic distortion)

DISC-MM 2.5 mV/47 kilohms

(Max. input capability; 200 mV at 1 kHz, less than 0.01% total harmonic distortion)

DISC-DA 150 mV/47 kilohms

AUX, TUNER, TAPE PLAY-1, 2

..... 150 mV/47 kilohms

Output level (1,000 Hz)

TAPE REC-1, 2 150 mV into 47 kilohms

Signal to noise ratio (short-circuit, A-network)

DISC-MC 80 dB

DISC-MM 90 dB

AUX, TUNER, TAPE PLAY-1, 2

..... 110 dB

Controls and Filter

BASS \pm 10 dB at 50 Hz

Tone selector..... 125 Hz, 250 Hz

TREBLE..... \pm 10 dB at 10 kHz

Tone selector..... 3 kHz, 6 kHz

SUBSONIC -3 dB at 16 Hz (6 dB/oct)

MUTING -20 dB

LOUDNESS +8 dB at 50 Hz

(VOLUME: -30 dB +6 dB at 10kHz position)

Power requirements

Power voltage..... 120/220/240V (50/60 Hz)

For U.S.A. & Canada

..... 120V (60 Hz)

Power consumption.... 470 watts 560 VA Rated

700 watts Maximum

Dimensions 466 mm (18-3/8") W

161 mm (6-3/8") H

431 mm (17") D

Weight 17 kg (37.4 lbs) net

19 kg (41.8 lbs) packed

* Design and specifications subject to changes without notice for improvements.



SANSUI ELECTRIC CO., LTD.

1. BLOCK DIAGRAM

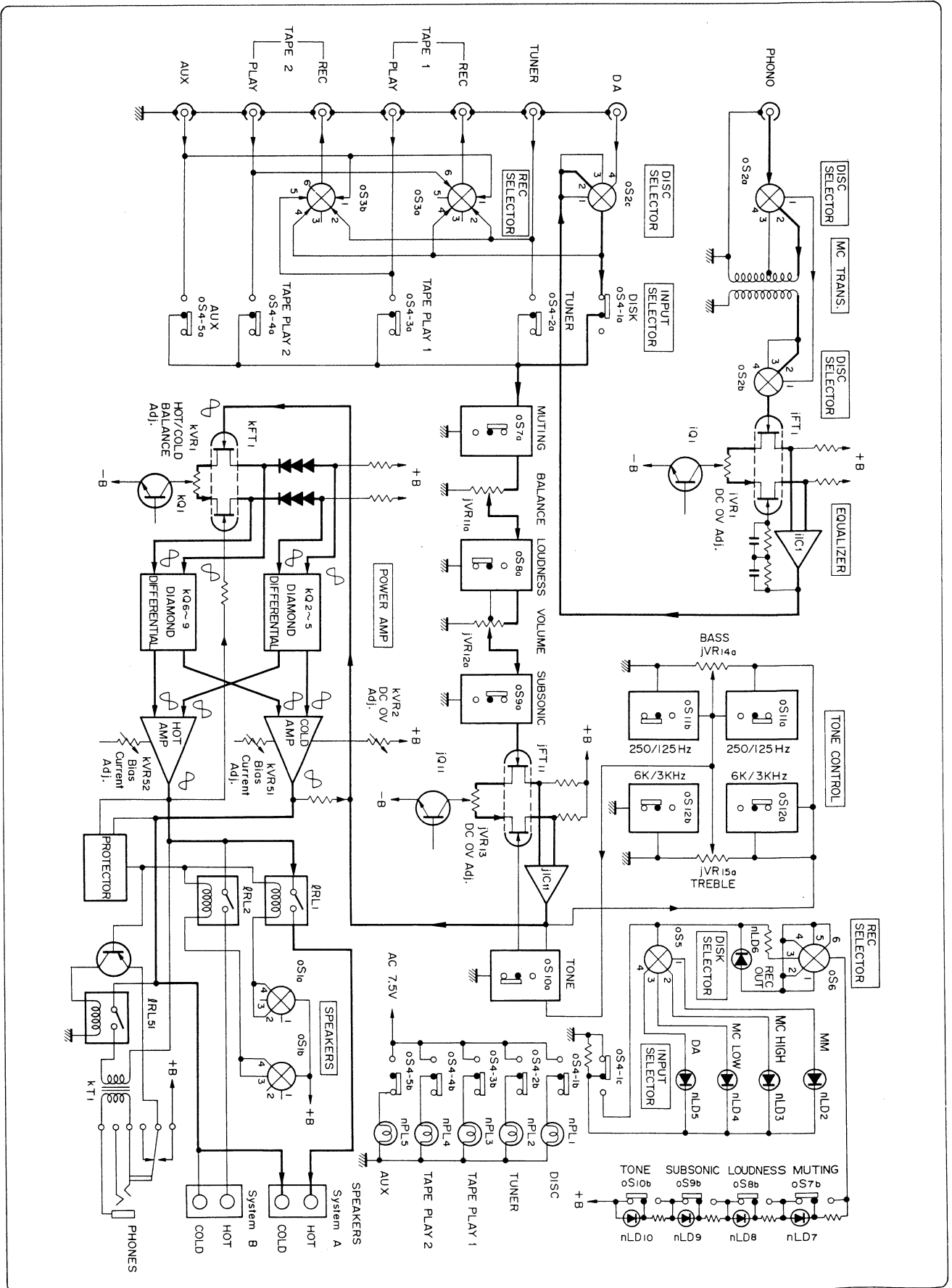

2. PARTS LOCATION & PARTS LIST

2-1. F-4263 Equalizer Amp. Circuit Board (Stock No. 00763301)

Component Side

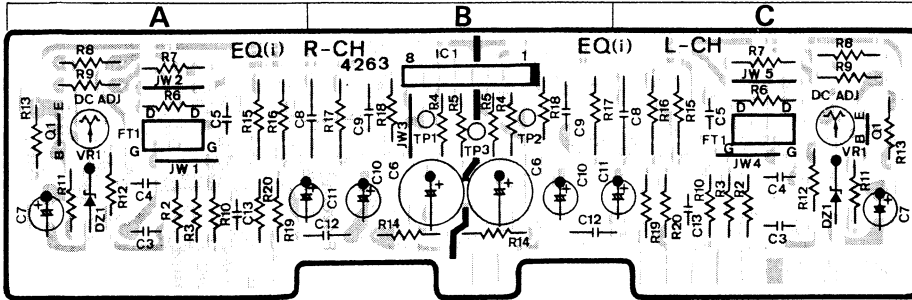

Parts List

Parts No.	Stock No.	Description
• Transistor		
iQ1	46581701	2SC1845
• FET		
iFT1	46723601 or 46723602	2SK389-BL 2SK389-V
• IC		
iIC1	46579100	M5219L
• Zener Diode		
iDZ1	46111800	05Z6.2-Y

Parts No.	Stock No.	Description
iR15	46456100	56kΩ 1/2W C.R.
iR16	46452300	1.5kΩ 1/2W C.R.
iR17	46453500	4.7kΩ 1/2W C.R.
iC8	00414500	0.056μF 100V P.C.
iC9	00413200	0.016μF 100V P.C.
iC12	46891600	0.047μF 100V F.C.
iC13	46884300	4700pF 100V F.C.
iVR1	46726700	200Ω(B) S.V.R., DC 0V Adj.

2-2. F-4266 Driver Amp. Circuit Board (Stock No. 00763401)

Component Side

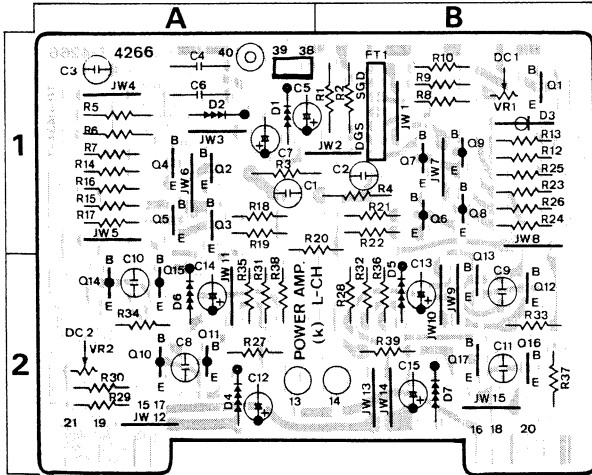

Parts List

Parts No.	Stock No.	Description
• Transistor		
kQ1	46581701	2SC1845
kQ2	46581701	2SC1845
kQ3	46581701	2SC1845
kQ4	46581701	2SC1845
kQ5	46581701	2SC1845
kQ6	46581601	2SA992
kQ7	46581601	2SA992
kQ8	46581601	2SA992
kQ9	46581601	2SA992
kQ10	46728201	2SA1145
kQ11	46728201	2SA1145
kQ12	46728301	2SC2705
kQ13	46728301	2SC2705
kQ14	46728201	2SA1145

Parts No.	Stock No.	Description
kQ15	46728201	2SA1145
kQ16	46728301	2SC2705
kQ17	46728301	2SC2705
• FET		
kFT1	07110000 or 07110001	μPA68H-L μPA68H-M
kD1	03401700	Varistor MV103
kD2	03401700	Varistor MV103
kD3	46445300	10YD2.4 (Constant Current)
kD4	03402000	Varistor SV04
kD5	03402000	Varistor SV04
kD6	03402000	Varistor SV04
kD7	03402000	Varistor SV04
kR1	46451900	1kΩ 1/2W C.R.
kR2	46452000	1.1kΩ 1/2W C.R.
kR3	46455600	36kΩ 1/2W C.R.
kR4	46455600	36kΩ 1/2W C.R.
kR5	46453300	3.9kΩ 1/2W C.R.
kR6	46453300	3.9kΩ 1/2W C.R.
△ kR29	46229200	150Ω 1/2W N.I.R.
△ kR30	46229600	330Ω 1/2W N.I.R.
△ kR33	46229100	120Ω 1/2W N.I.R.
△ kR34	46229100	120Ω 1/2W N.I.R.
△ kR37	46229100	120Ω 1/2W N.I.R.
kC3	46917800	1500pF 125V P.C.
kC4	00407400	0.033μF 100V F.C.
kC6	00407400	0.033μF 100V F.C.
kVR1	10335700	100Ω(B) S.V.R., HOT/COLD DC Balance Adj.
kVR2	10336100	470Ω(B) S.V.R., DC 0V Adj.

2-3. F-4267 Driver Amp. Circuit Board

Component Side (Stock No. 00763501)

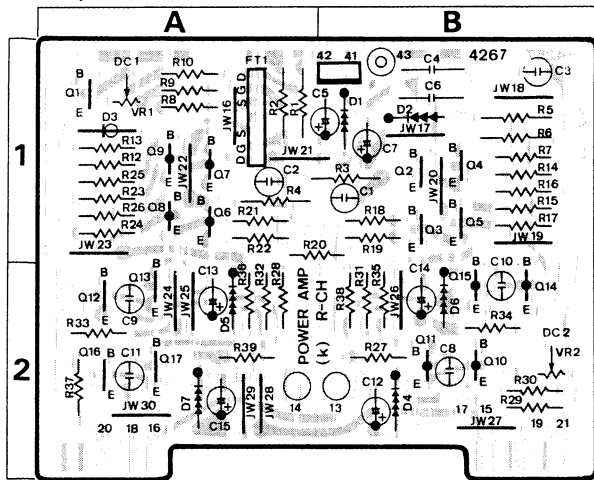

Parts List

Parts No.	Stock No.	Description
•Transistor		
kQ1	46581701	2SC1845
kQ2	46581701	2SC1845
kQ3	46581701	2SC1845
kQ4	46581701	2SC1845
kQ5	46581701	2SC1845
kQ6	46581601	2SA992
kQ7	46581601	2SA992
kQ8	46581601	2SA992
kQ9	46581601	2SA992
kQ10	46728201	2SA1145
kQ11	46728201	2SA1145
kQ12	46728301	2SC2705
kQ13	46728301	2SC2705
kQ14	46728201	2SA1145
kQ15	46728201	2SA1145
kQ16	46728301	2SC2705
kQ17	46728301	2SC2705
•FET		
kFT1	07110000 or 07110001	μ PA68H-L μ PA68H-M
kD1	03401700	Varistor MV103
kD2	03401700	Varistor MV103
kD3	46445300	10YD.2 (Constant Current)
kD4	03402000	Varistor SV04
kD5	03402000	Varistor SV04
kD6	03402000	Varistor SV04
kD7	03402000	Varistor SV04
KR1	46451900	1k Ω 1/2W C.R.
KR2	46452000	1.1k Ω 1/2W C.R.
KR3	46455600	36k Ω 1/2W C.R.
KR4	46455600	36k Ω 1/2W C.R.
KR5	46453300	3.9k Ω 1/2W C.R.
KR6	46453300	3.9k Ω 1/2W C.R.
Δ KR29	46229200	150 Ω 1/2W N.I.R.
Δ KR30	46229600	330 Ω 1/2W N.I.R.
Δ KR33	46229100	120 Ω 1/2W N.I.R.
Δ KR34	46229100	120 Ω 1/2W N.I.R.
Δ KR37	46229100	120 Ω 1/2W N.I.R.
kC3	46917800	1500pF 125V P.C.
kC4	00407400	0.033 μ F 100V F.C.
kC6	00407400	0.033 μ F 100V F.C.
KVR1	10335700	100 Ω (B) S.V.R., HOT/COLD DC Balance Adj.
KVR2	10336100	470 Ω (B) S.V.R., DC 0V Adj.

2-4. F-4268 Protector Circuit Board

Component Side (Stock No. 00763601)

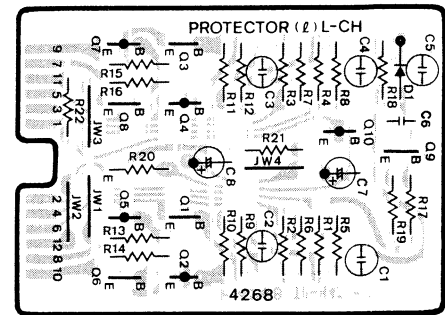

Parts List

Parts No.	Stock No.	Description
•Transistor		
IQ1	46367101	2SC2603
IQ2	46367001	2SA1115
IQ3	46367101	2SC2603
IQ4	46367001	2SA1115
IQ5	46367001	2SA1115
IQ6	46367101	2SC2603
IQ7	46367001	2SA1115
IQ8	46367101	2SC2603
IQ9	46367101	2SC2603
IQ10	46367001	2SA1115
•Diode		
ID1	03117600 or 46086000	1S2473T77 1S1588
IC6	46882700	1000pF 100V F.C.

2-5. F-4269 Protector Circuit Board

Component Side (Stock No. 00763701)

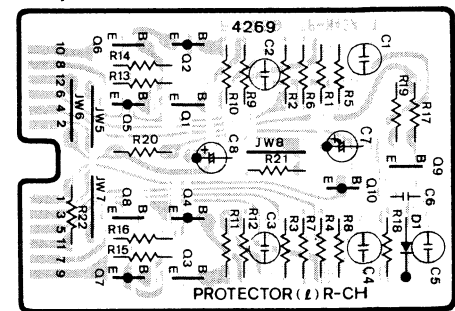

Parts List

Parts No.	Stock No.	Description
•Transistor		
IQ1	46367101	2SC2603
IQ2	46367001	2SA1115
IQ3	46367101	2SC2603
IQ4	46367001	2SA1115
IQ5	46367001	2SA1115
IQ6	46367101	2SC2603
IQ7	46367001	2SA1115
IQ8	46367101	2SC2603
IQ9	46367101	2SC2603
IQ10	46367001	2SA1115
•Diode		
ID1	03117600 or 46086000	1S2473T77 1S1588
IC6	46882700	1000pF 100V F.C.

2-6. F-4271 Input Selector Circuit Board

Component Side

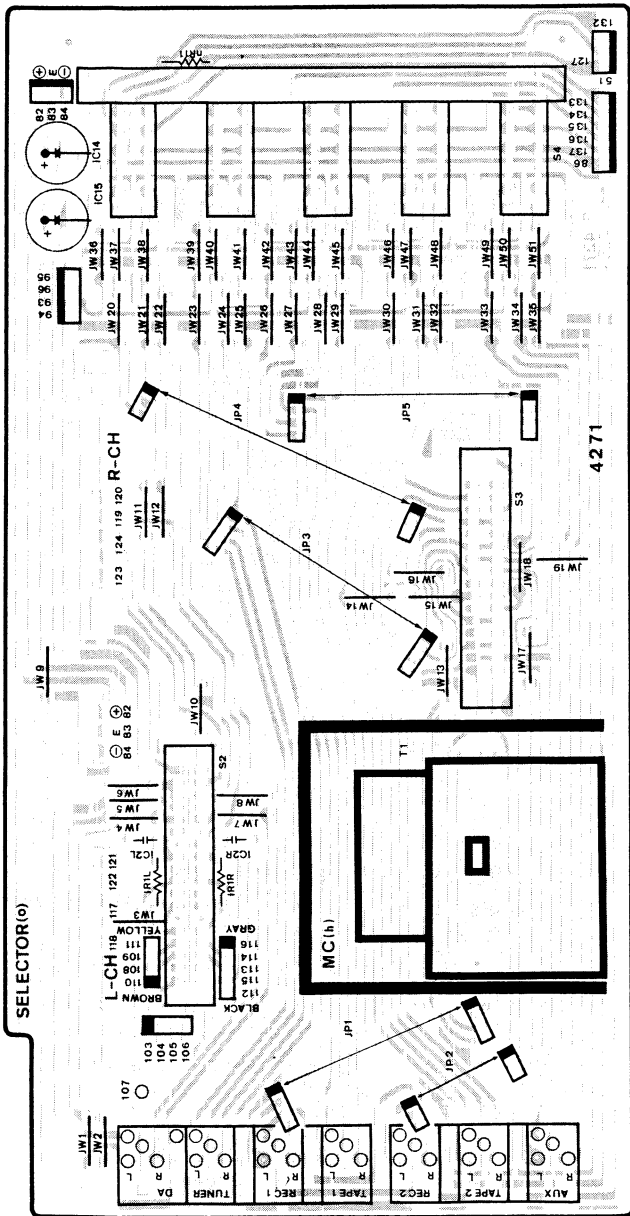

Parts List

Parts No.	Stock No.	Description
hT1	46726000	MC Head Transformer
oS2	07186500	Slide SW., DISC SELECTOR
oS3	07200200	Slide SW., REC SELECTOR
oS4	46726800	Push SW., INPUT SELECTOR
	46684900	2P Input Terminal, DA
	46685200	6P Terminal, TUENR, TAPE 1/2, AUX

2-7. F-4270 MM/MC Input Terminal Board

Component Side

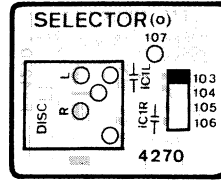

Parts List

Parts No.	Stock No.	Description
	46684900	2P Input Terminal Board, PHONO

2-8. F-4272 DISK & REC Selector Circuit Board

Component Side

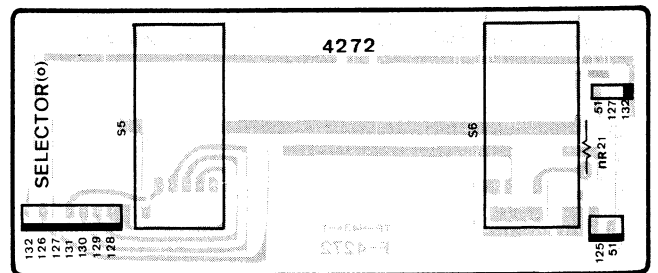

Parts List

Parts No.	Stock No.	Description
oS5	46726510	Rotary SW., DISC SELECTOR
oS6	46726610	Rotary SW., REC SELECTOR

2-9. F-4274 VOLUME Control Board

Component Side

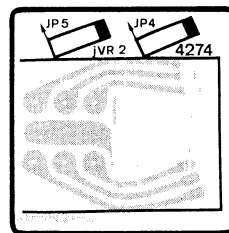

Parts List

Parts No.	Stock No.	Description
vVR12	46737100	100kΩ V.R., VOLUME

2-10. F-4273 Control Amp. Circuit Board (Stock No. 00764101)

Component Side

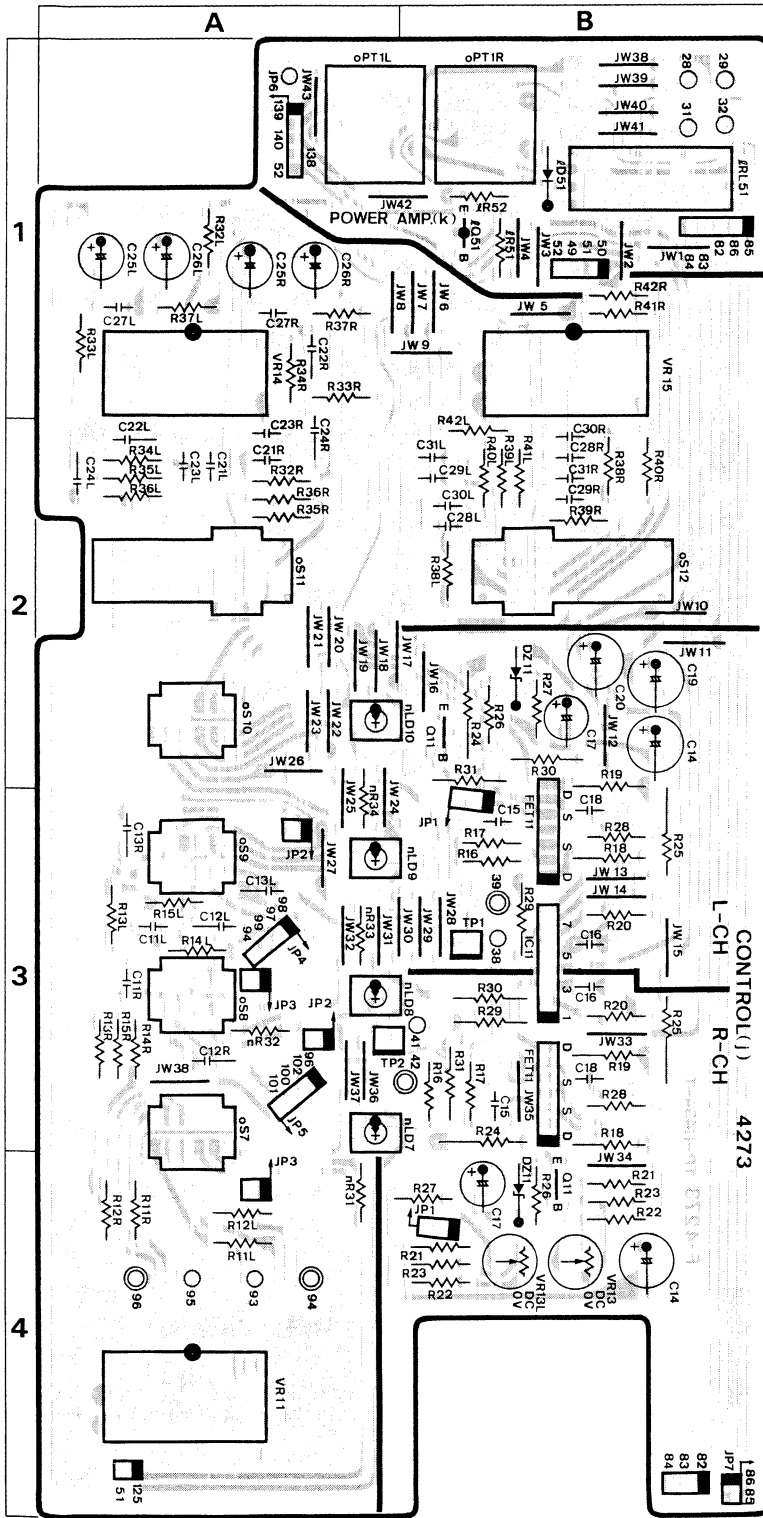

Parts List

Parts No.	Stock No.	Description
• Transistor		
jQ11	46581701	2SC1845
• FET		
jFT11	07110000 or 07110001	μPA68H-L μPA68H-M
• IC		
jIC11	46579100	M5219L
• Zener Diode		
jDZ11	46111800	05Z6.2-Y
jR29	46449500	100Ω 1/2W C.R.
jR30	46453700	5.6kΩ 1/2W C.R.
jR31	46451900	1kΩ 1/2W C.R.
jC12	46887100	0.068μF 100V F.C.
jC13	46886600	0.043μF 100V F.C.
jC21	46885500	0.015μF 100V F.C.
jC22	46887300	0.082μF 100V F.C.
jC23	46885700	0.018μF 100V F.C.
jC24	46887500	0.1μF 100V F.C.
jC27	46886700	0.047μF 100V F.C.
jC28	46882700	1000pF 100V F.C.
jC29	46884600	6200pF 100V F.C.
jC30	46882700	1000pF 100V F.C.
jC31	46884600	6200pF 100V F.C.
jVR11	46731800	250kΩ V.R., BALANCE
jVR13	46738100	100Ω S.V.R., DC 0V Adj.
jVR14	46731900	100kΩ V.R., BASS
jVR15	46731900	100kΩ V.R., TREBLE
Δ kR82	46228400	33Ω 1/2W N.I.R.
KT1	46841800	Output Transformer, PHONES
• Transistor		
IQ51	07197001	2SA733A
• Diode		
ID51	03117600	1S2473T77
IRL51	11504300 or 11504301	Relay, PHONES Relay, PHONES
nLD7	46176900	LED TLS-123, MUTING
nLD8	46176900	LED TLS-123, LOUDNESS
nLD9	46176900	LED TLS-123, SUBSONIC
nLD10	46176900	LED TLS-123, TONE
oS7	46736800	Push SW., MUTING
oS8	46736800	Push SW., LOUDNESS
oS9	46736800	Push SW., SUBSONIC
oS10	46736800	Push SW., TONE
oS11	46730600	Push SW., BASS
oS12	46730600	Push SW., TREBLE

2-11. F-4287 Protector Circuit Board (Stock No. 00764501)

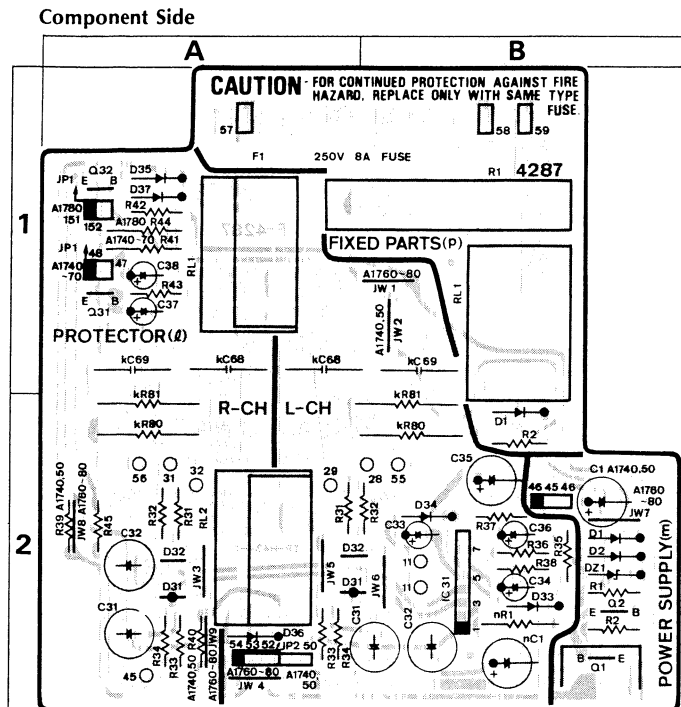

Parts No.	Stock No.	Description
ID34	03111800 or 07176400	1S1588 1S2473HS
ID35	03117700	10E-2
ID36	03117700	10E-2
ID37	03111800 or 07176400	1S1588 1S2473HS
△ IR38	46230300	1.2kΩ 1/2W N.I.R.
△ IR39	46227800	10Ω 1/2W N.I.R.
△ IR40	46227800	10Ω 1/2W N.I.R.
△ IR41	46250800	1.8kΩ 1/2W N.I.R.
IC31	00304400	100μF 16V E.B.
IC32	00304400	100μF 16V E.B.
IRL1	46446400	Relay, SPEAKERS SYSTEM A
IRL2	46446400	Relay, SPEAKERS SYSTEM B
• Transistor		
△ mQ1	03086101	2SD357
mQ2	03067401	2SC1845
• Diode		
mD1	03117700	10E-2
mD2	03117700	10E-2
• Zener Diode		
mDZ1	46105800	05Z24-Y
△ mR1	46228400	33Ω 1/2W N.I.R.
△ mR2	46230200	1kΩ 1/2W N.I.R.
△ nR1	46250800	1.8kΩ 1W N.I.R.
	46739500	8P Output Terminal, SPEAKERS
• Diode		
pD1	03117700	10E-2
△ pR1	46739900	3.9Ω 10W Ce.R.
△ pF1	07189100	5A 250V Power Fuse, <220/240V> (XX)
△	07189500	10A 250V Power Fuse, <120V> (XX, CSA)
△	07185300	4A 250V Power Fuse, <220/240V> (EU)
△ pRL1	46222200	Relay, In-rush Prevention

Parts List

Parts No.	Stock No.	Description
△ KR80	00185500	10Ω 2W N.I.R.
△ KR81	00185500	10Ω 2W N.I.R.
KC68	46615100	0.047μF 50V P.C.
KC69	46615100	0.047μF 50V P.C.
• Transistor		
IQ31	07194801	2SC1815
IQ32	07194801	2SC1815
• IC		
△ IIC31	03609000	HA12002
• Diode		
ID31	46463900	MC921
ID32	46463700	MC911
ID33	03117700	10E-2

2-12. F-4275 Input Indicator Lamp Board

Component Side

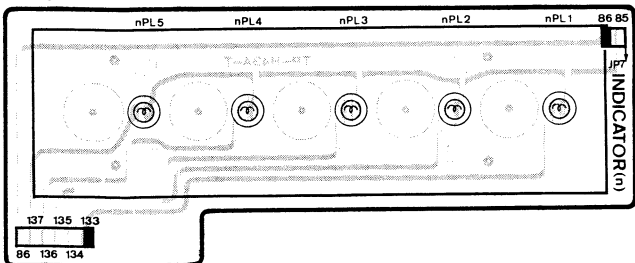

Parts List

Parts No.	Stock No.	Description
nPL1	46730000	8V 0.1A Pilot Lamp, DISC
nPL2	46730000	8V 0.1A Pilot Lamp, TUNER
nPL3	46730000	8V 0.1A Pilot Lamp, TAPE PLAY 1
nPL4	46730000	8V 0.1A Pilot Lamp, TAPE PLAY 2
nPL5	46730000	8V 0.1A Pilot Lamp, AUX

2-13. F-4276 PHONES Jack Board

Component Side

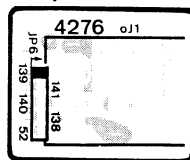

Parts List

Parts No.	Stock No.	Description
oJ1	46078200	Jack, PHONES

5. SCHEMATIC DIAGRAM 5-1. Power Amp. Section

*Design and specifications subject to change without notice for improvement.
 *La présentation et les spécifications sont susceptibles d'être modifiées sans préavis par suites d'améliorations éventuelles.
 *Änderungen, die dem technischen Fortschritt dienen, bleiben vorbehalten.

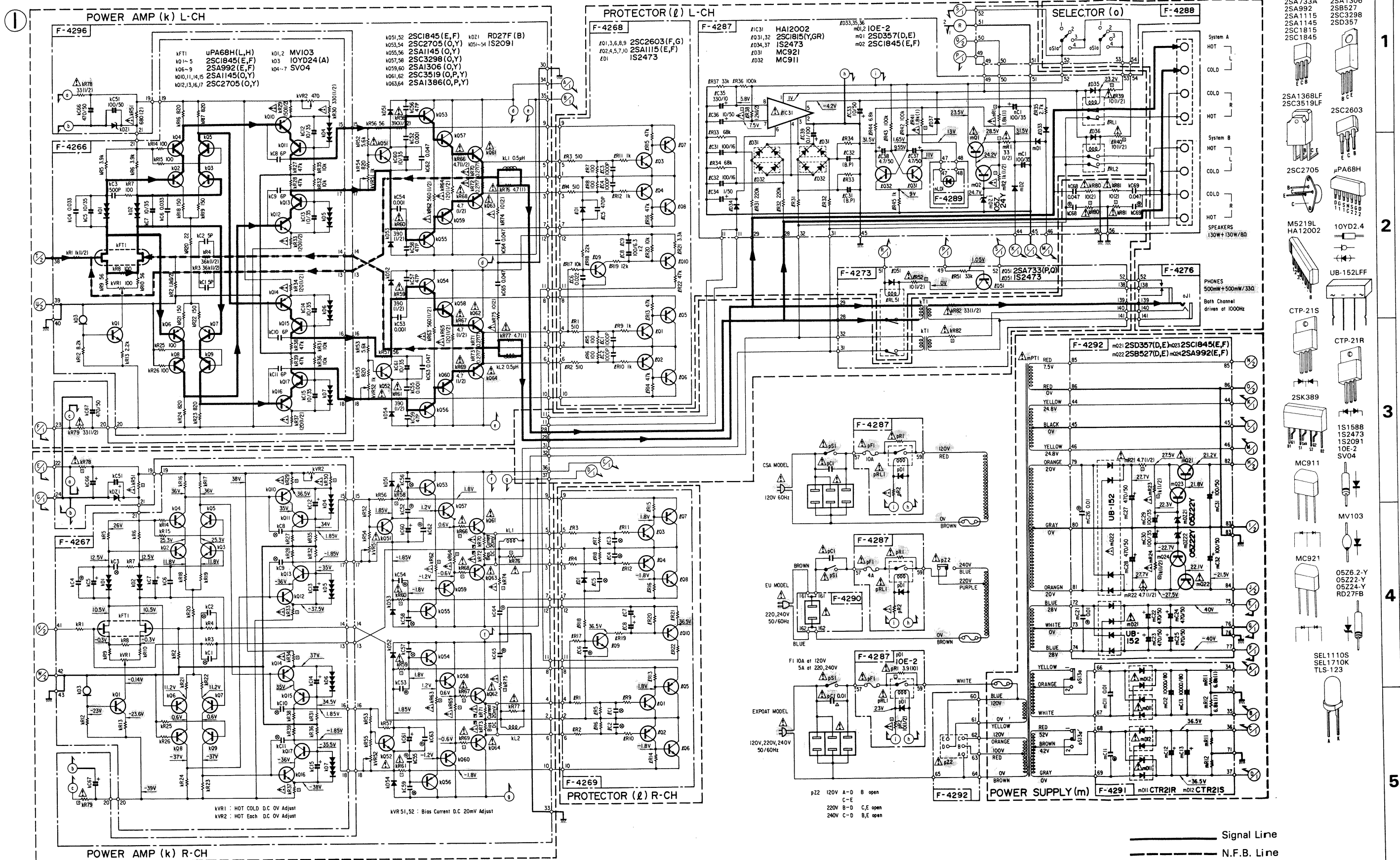

1
2
3
4
5

5-2. Pre Amp. Section

*Design and specifications subject to change without notice for improvement.
 *La présentation et les spécifications sont susceptibles d'être modifiées sans préavis par suites d'améliorations éventuelles.
 *Änderungen, die dem technischen Fortschritt dienen, bleiben vorbehalten.

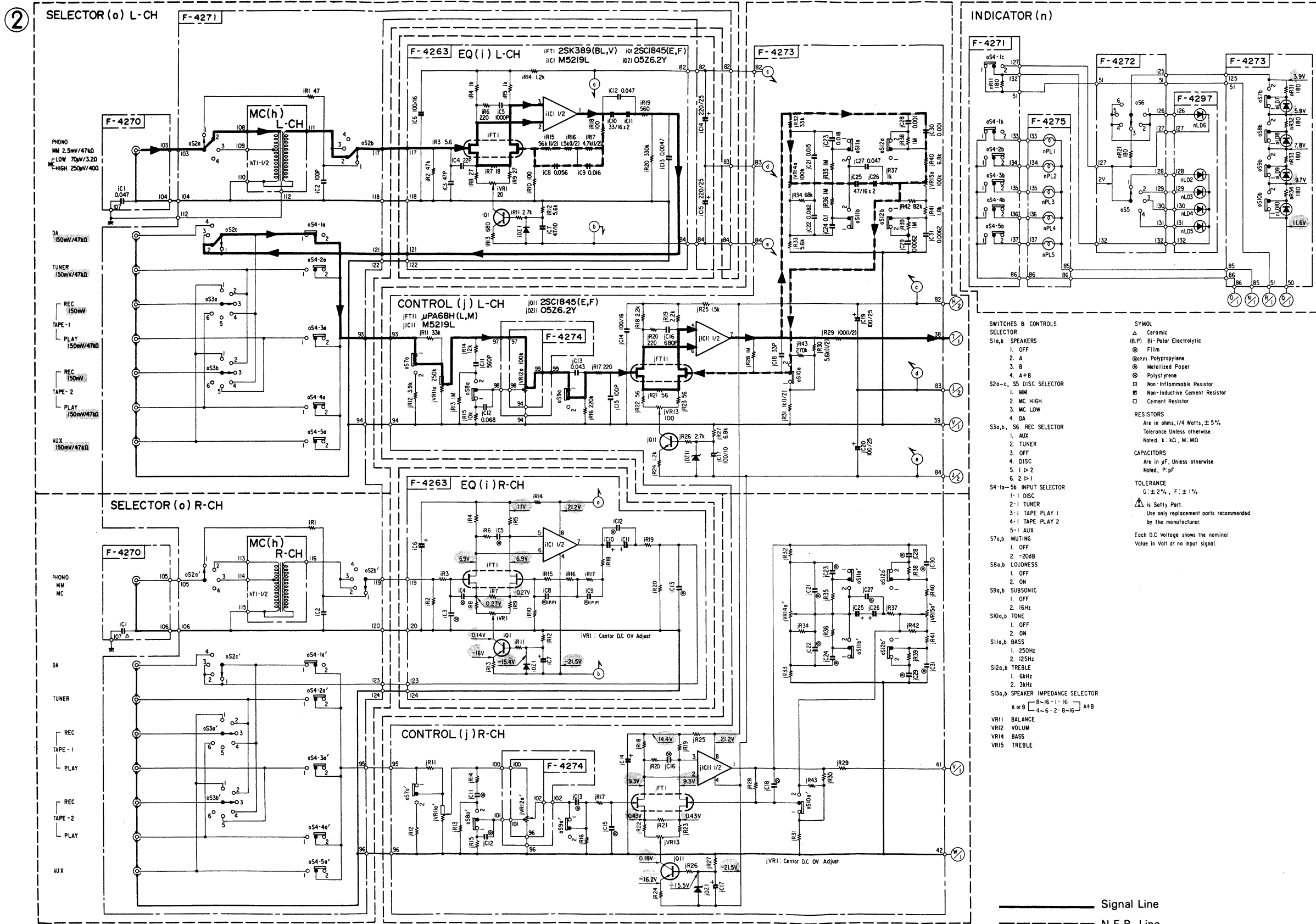

- 2SA733A
- 2SA992
- 2SA1115
- 2SA1145
- 2SC1815
- 2SC1845
- 2SA1306
- 2SB527
- 2SC3298
- 2SD357
- 2SA1368LF
- 2SC3519LF
- 2SC2705
- μPA68H
- M5219L
- HA12002
- 10YD2.4
- UB-152LFF
- CTP-21S
- CTP-21R
- 2SK389
- 1S1598
- 1S2473
- 1S2091
- 10E-2
- SV04
- MC911
- MV103
- MC921
- 05Z6.2-Y
- 05Z22-Y
- 05Z24-Y
- RD27FB
- SEL1110S
- SEL1710K
- TLS-123

- SWITCHES & CONTROLS**
- S1a,b SELECTOR
 - 1. OFF
 - 2. A
 - 3. B
 - 4. A+B
 - S2a-c, S5 DISC SELECTOR
 - 1. MM
 - 2. MC HIGH
 - 3. MC LOW
 - S3a,b, S6 REC SELECTOR
 - 1. AUX
 - 2. TUNER
 - 3. OFF
 - 4. DISC
 - 5. 1 P-2
 - 6. 2 P-1
 - S4-1a-5b INPUT SELECTOR
 - 1-1. DISC
 - 2-1. TUNER
 - 3-1. TAPE PLAY 1
 - 4-1. TAPE PLAY 2
 - 5-1. AUX
 - S7a,b MUTING
 - 1. OFF
 - 2. -20dB
 - S8a,b LOUDNESS
 - 1. OFF
 - 2. ON
 - S9a,b SUBSONIC
 - 1. OFF
 - 2. 16Hz
 - S10a,b TONE
 - 1. OFF
 - 2. ON
 - S11a,b BASS
 - 1. 250Hz
 - 2. 125Hz
 - S12a,b TREBLE
 - 1. 6kHz
 - 2. 3kHz
 - S13a,b SPEAKER IMPEDANCE SELECTOR
 - A or B
 - B-16-1-16
 - A+B
 - 4-6-2-8-16
 - A+B
- SYMBOL**
- △ Ceramic
 - ⊖ Bi-Polar Electrolytic
 - Film
 - ⊗ Polypropylene
 - ⊙ Metallized Paper
 - ⊕ Polystyrene
 - ⊖ Non-Inductive Cement Resistor
 - ⊕ Cement Resistor
- RESISTORS**
- Are in ohms, 1/4 Watts, ± 5%
 Tolerance Unless otherwise
 Noted: k, M, Ω
- CAPACITORS**
- Are in μF, Unless otherwise
 Noted: P, pF
- TOLERANCE**
- G: ± 2%, F: ± 1%
- ⚠ is Safety Part.
 Use only replacement parts recommended
 by the manufacturer.
- Each D.C. Voltage shows the nominal
 Value in Volt of no input signal.

— Signal Line
 - - - N.F.B. Line

1
 2
 3
 4
 5

2-14. F-4288 SPEAKERS Selector Board
Component Side

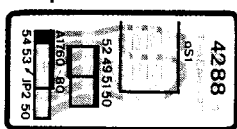

Parts List

Parts No.	Stock No.	Description
oS1	46730700	Rotary SW., SPEAKERS

2-15. F-4289 PROTECTOR LED Board
Component Side

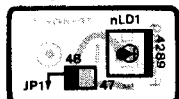

Parts List

Parts No.	Stock No.	Description
nLD1	03193700	LED SEL110S, PROTECTOR

2-16. F-4291 Power Supply Circuit Board
Component Side

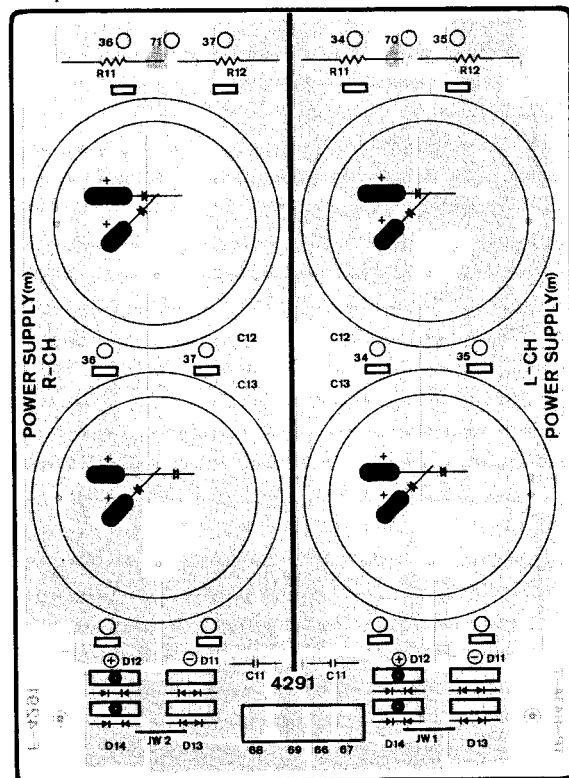

Parts List

Parts No.	Stock No.	Description
•Diode		
△mD11	46731400	CTP-21R
△mD12	46731500	CTP-21S
mR11	46510500	6.8kΩ 1W C.R.
mR12	46510500	6.8kΩ 1W C.R.
mC11	07287400	0.01μF 630V F.C.
mC12	46729200	10000μF 80V E.C.
mC13	46729200	10000μF 80V E.C.

2-17. F-4292 Power Supply Circuit Board
Component Side

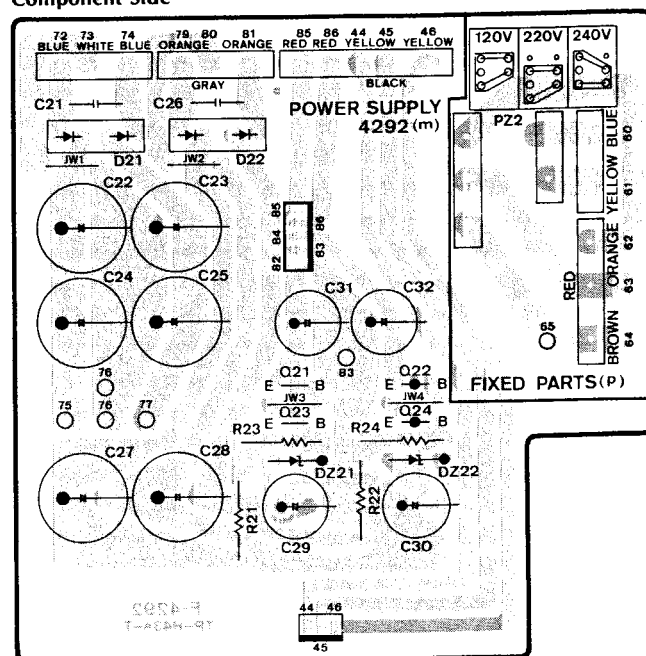

Parts List

Parts No.	Stock No.	Description
•Transistor		
△mQ21	03086101	2SD357
△mQ22	03034401	2SB527
mQ23	03067401	2SC1845
mQ24	03010901	2SA992
•Diode		
△mD21	07193300	UB-152LFF
△mD22	07193300	UB-152LFF
•Zener Diode		
mDZ21	46105500	05Z22-Y
mDZ22	46105500	05Z22-Y
△mR21	08921300	4.7Ω 1/2W N.I.R.
△mR22	08921300	4.7Ω 1/2W N.I.R.
△mR23	08924100	1kΩ 1/2W N.I.R.
△mR24	08924100	1kΩ 1/2W N.I.R.
mC21	07287400	0.01μF 630V F.C.
mC22	46628500	470μF 50V E.C.
mC23	46628500	470μF 50V E.C.
mC24	46628500	470μF 50V E.C.
mC25	46628500	470μF 50V E.C.
mC26	07287400	0.01μF 630V F.C.
mC27	46628500	470μF 50V E.C.
mC28	46628500	470μF 50V E.C.
mC31	46628100	100μF 50V E.C.
mC32	46628100	100μF 50V E.C.

7. PACKING LIST

Parts No.	Stock No.	Description
1	91167720	Vinyl Bag
2	47332800	Styrofoam Packing
3	47330200	Carton Case

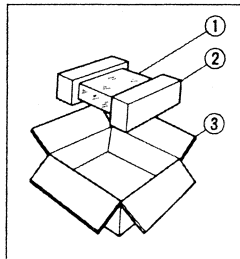

8. ACCESSORY LIST

Stock No.	Description
46729000	Operating Instruction
46894400	Connection Diagram



SANSUI ELECTRIC CO., LTD.:
 SANSUI ELECTRONICS CORPORATION:
 SANSUI ELECTRONICS (U.K.) LTD.:
 SANSUI ELECTRONICS G.M.B.H.:

14-1, Izumi 2-chome, Suginami-ku, Tokyo 168 Japan
 PHONE: (03) 324-8891/TELEX: 232-2076 (International Division)
 1250 Valley Brook Ave. Lyndhurst, N.J. 07071 U.S.A.
 17150 South Margay Ave. Carson, California 90746 U.S.A.
 3306 Koapaka 5t. Honolulu, Hawaii 96819 U.S.A.
 Unit 10A, Lyon Industrial Estate, Rockware Avenue, Geenford, Middx UB6, OAA, England
 Pau Ehrich Strasse 8, 6074 Rödermark 2, West Germany