

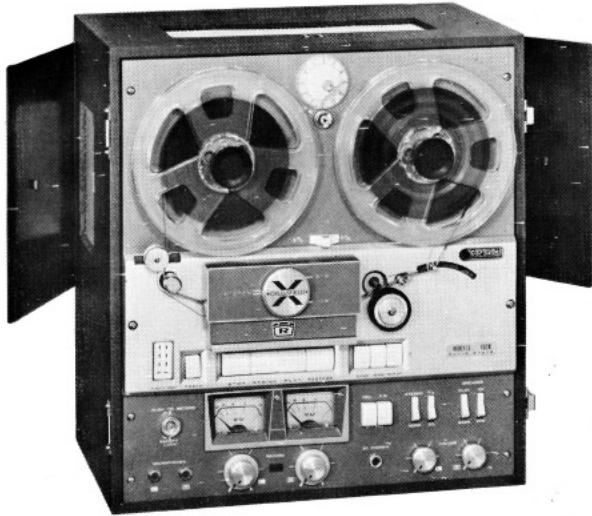

# SERVICE MANUAL



Rheem-Roberts 400X



Rheem-Roberts 5000 series

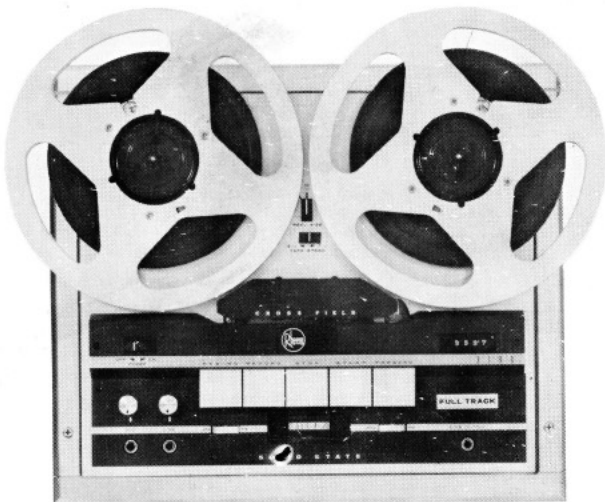

Rheem-Califone 3190 series



# INTRODUCTION

The purpose of this manual is to assist the technician in adjusting and repairing the Rheem 400X, 3190, and 5000 series recorders. The manual is not intended as a basic handbook on magnetic tape recorders, as several texts which are very comprehensive are readily available. Consequently, a working knowledge of basic recording theory and practice is assumed and only items peculiar to these machines are discussed.

The 400X, 5000, and 3190 are three motor (including dual speed hysteresis-synchronous capstan motor), fully transistorized professional tape recorders, designed to be used in the studio or out in the field, as their features make them capable of competing with the highest price console units, yet their size and weight permit them to be readily carried to a remote location for on-the-spot broadcast quality recordings. The self-contained power amplifiers in the 400X and 5000X drive the high-quality monitor speakers and provide 34 watts peak power per channel to the external speaker jacks.

The Rheem 3190 series is the studio configuration of the 5000 series. The 3190 series features the tape transport and electronics used in the 5000 series, but without the portable case. The 3190 series may be console or rack mounted. The Rheem 3190 and 5000 series are available as quarter track stereo, half track mono, and full track mono units, designated by the suffix letter of the series number. "S" indicates quarter track; "H" indicates half track; and "F" indicates full track heads.

The 400X, 5000, and 3190 make use of the Crossfield bias system. This new system of supplying the bias to the tape permits the recording of high frequencies at tape speeds heretofore considered too slow for suitable reproduction. The bias is supplied by a separate head from the back of the tape and slightly before the tape passes the trailing edge of the record head gap. Consequently, the higher frequencies, which are more subject to partial erasure from the bias than the lower frequencies, are retained as they are recorded, yet sufficient bias is applied over the rest of the record head gap area to permit undistorted recording of lower frequencies and a low noise level. The results are impressive, as the units are capable of recording and reproducing from 30 cps to 17,000 cps,  $\pm 3$  db at  $3\frac{3}{4}$  ips, with a signal-to-noise ratio of 50 db.

## INDEX TO CONTENTS

Controls and Features of the 5000 and 3190 Series .....	3	Brake Adjustment .....	7
Basic Recording Procedures, 5000 and 3190 .....	4	Motor Service .....	7
Controls and Features of the 400X .....	4	Component Identification Photos .....	8
Basic Recording Procedures, 400X .....	5	Voltage Chart .....	8
Technical Specifications .....	6	Conversion to 220-240 Volts .....	12
Head Alignment .....	6	Conversion to 50 Cycles .....	12
Calibration Potentiometers, Adjustment of .....	7	Conversion to $7\frac{1}{2}$ -15 ips .....	12
Removal from Case .....	7	Troubleshooting the Recorders .....	12
Lubrication .....	7	Parts List .....	14
		Schematics .....	removable folding inserts

# CONTROLS AND FEATURES OF THE 5000 AND 3190 SERIES

## (5000X Shown Below)

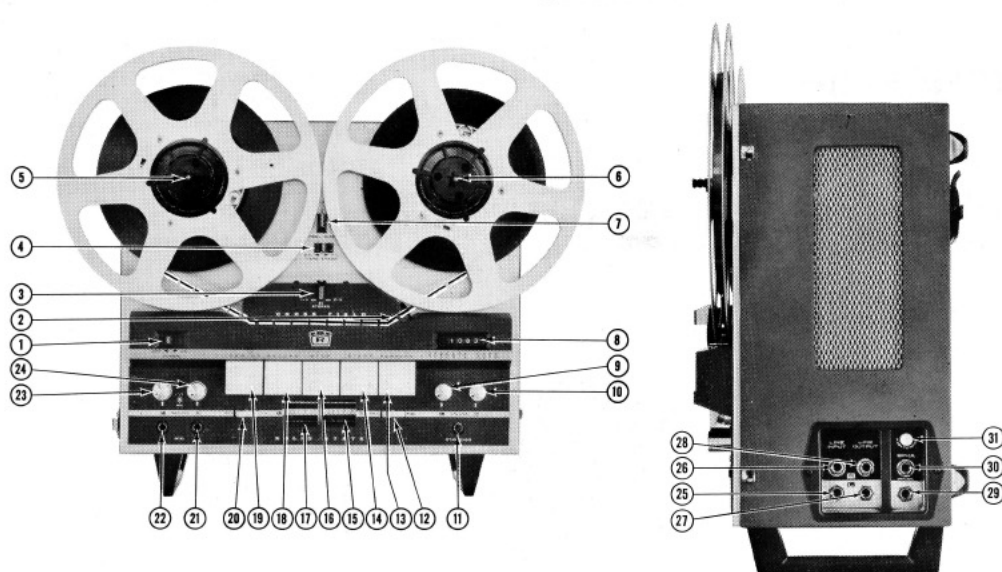

1. Power/Automatic Shut-off Switch.
  2. Automatic Shut-off Lever.
  3. Stereo-Monaural Selector Switch.
  4. Speed Selector Switch.
  5. Supply Reel Spindle and Lock.
  6. Takeup Reel Spindle and Lock.
  7. Tape Tension Switch.
  8. Index Counter and Reset Button.
  9. Left Play Volume Control.
  10. Right Play Volume Control.
  11. Stereo Headphone Jack.
  12. Record-Play Monitor Switch.
  13. Fast Forward Button.
  14. Play Button.
  15. Right VU Meter.
  16. Stop Button.
  17. Left VU Meter.
  18. Record Button.
  19. Rewind Button.
  20. Equalization Switch.
  21. Right Mike Input Jack.
  22. Left Mike Input Jack.
  23. Left Record Level Controls.
  24. Right Record Level Controls.  
(Inner Knob is Mike Level, Outer Ring is Line Level.)
  25. Left Line Input Jack.
  26. Right Line Input Jack.
  27. Left Line Output Jack.
  28. Right Line Output Jack.
  29. Left Speaker Output Jack.
  30. Right Speaker Output Jack.
  31. Bass Contour Switch.
- \*Model 5000X only.

**Note:** paragraph numbers refer to identification numbers on photo.

**1 & 2. The Power Switch** is combined with the Automatic Shutoff. To turn the unit on, the power switch must be placed in the "on" position. For normal operation it will remain on while the machine is in use. Should the operator desire that the electronics, as well as the deck, be automatically shut off following completion of the tape, the power switch is placed in the "off" position after the tape has been placed in motion. The tape will continue normally until the automatic shutoff lever drops, or until the stop button is pressed, at which time the entire machine will be shut off. Regardless of the position of the power switch, the deck will enter the Stop mode whenever the automatic shutoff lever drops or the Stop button is pressed.

**3. The Stereo-Mono Selector Switch** is combined with a Bias and Erase Head positioning cam.

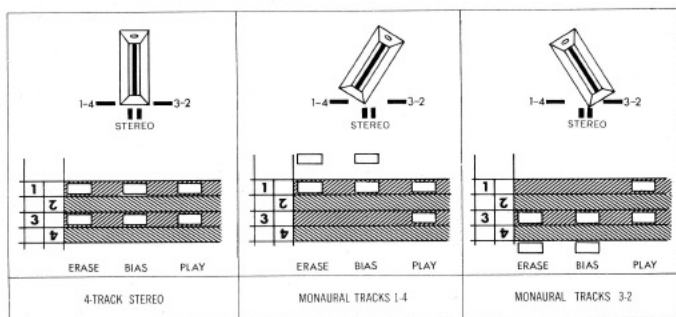

Turning of the knob selects the correct Record and Play heads electrically and positions the Bias and Erase heads on the tape to correspond with the track being recorded. Note: To minimize the possibility of magnetizing the Record head, the Stereo-Mono Switch should not be changed while the unit is in the Record mode.

**4 & 20. The Speed Selector Switch** electrically switches the direct drive hysteresis-synchronous capstan motor from  $7\frac{1}{2}$  ips to  $3\frac{3}{4}$  ips. The Equalization Switch should be used in conjunction with the speed selector to properly match the Record and the Play electronics to the selected tape speed for correct high frequency response.

**5 & 6. The Reel Locks** are utilized by pulling the end of the spindle out to clear the reels in use, then rotating one-third turn and releasing. They are unlocked by rotating one-third turn and allowing the fins to snap into the slots in the reel.

**7. The Tape Tension Switch** is used to select the voltage applied to the torque motors in Play and Record modes. For large diameter reels more torque is required to produce the correct tape tension across the heads. The switch is calibrated by reel size, and is set accordingly.

**8. The Index Counter** is of the precision four-digit type with push-button reset. Care should be taken to insure that the counter, when reset, is always reset to "0000" and that the button is released rapidly, to insure that the counter will re-engage with the drive gear. Note: When the counter is directly on the digit "five" it may be necessary to gently press the button more than once or to rotate the take-up spindle to move the counter slightly off the "5" in order to reset it.

**9 & 10. The Volume Controls** are used to regulate the internal or external loudspeaker levels only on the 5000X. The line outputs are preset. On the other models, the volume controls regulate the line output levels.

**11. The Stereo Headphone Jack** is a low-impedance outlet for monitoring or listening without the use of loudspeakers. The headphone level is pre-set.

**12. The Record-Play Monitor Switch** is used to select whether the output will be either playback from the tape or a monitor of the incoming signal. The monitor levels are pre-set to be within 1 db of each other so that when recording one may monitor either the input or the recorded program with no apparent difference in tone or level.

**13. The Fast Forward Button** is used to rapidly advance the tape to a desired selection, easily located by use of the counter. The Fast Forward Button may be activated only from Stop or Rewind modes.

**14. The Play Button** is used to start the tape in motion in either Play or Record modes. The Play Button may be activated only from the Stop mode.

**15 & 17. The VU Meters** are used to correctly balance the recording level for minimum noise and distortion. The meters should indicate around mid-scale for average program material. Only on extremely loud passages should the needles be permitted to pass above the center of the red portion of the scale for more than an instant. The amplifiers are calibrated to record within 1 db of the NAB standard operating level when the needle is indicating zero VU. When the monitor switch is changed from Record to Playback, the meters will indicate the recorded level on the tape.

**16. The Stop Button** is used to bring the tape to a halt from any mode.

**18. The Record Button** is pressed at the same time as the Play button to place the unit into the Record mode. The Record button is interlocked in such a fashion as to prevent its remaining in unless it is held in while the Play button is pressed.

**19. The Rewind Button** is used to rapidly rewind the tape. The Rewind Button may be activated only from the Stop or Fast Forward modes.

**21 & 22, 23 & 24, 25 & 26. The Mike Inputs** are of the medium to high impedance type, suitable for use with high-quality

microphones of the dynamic type. The mike levels are controlled by the inner knob on each channel.

**The Line Inputs** are sensitive, high impedance types capable of handling any signal normally encountered down to 50 millivolts. The line levels are controlled by the outer ring on each channel.

Note: For monaural recording on either track, only left channel inputs are used.

**27 & 28. The Line Outputs** provide up to 1.5 volts into a high-impedance load.

**\*29 & 30. The Speaker Outputs** will provide adequate power (34 watts peak per channel) to drive any external 8 ohm

impedance loudspeaker. The internal speakers are automatically disconnected when external speakers are plugged in.

**\*31. The Bass Contour Switch** in the normal (out) position gives flat frequency response from the power amplifier. In many cases it may be desirable to boost the bass to compensate for external factors or low listening levels. This is accomplished by pressing the Bass Contour Switch in.

Note: This switch is effective only with the internal and external speakers, not with the line outputs, nor does it affect the record amplifiers.

\*Model 5000X.

## BASIC RECORDING PROCEDURES, 5000 AND 3190

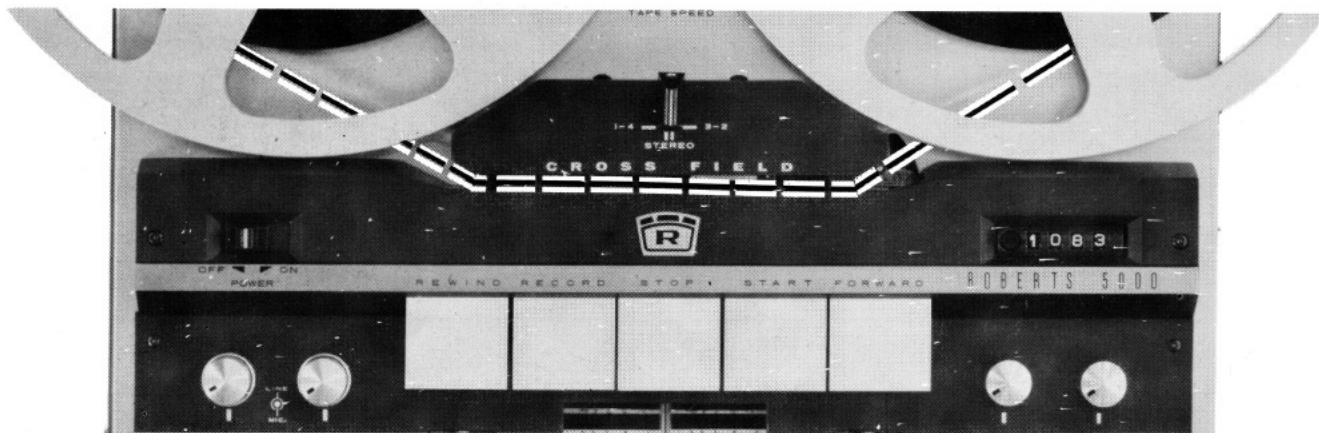

Turn power on after plugging power cord into 110-120V 60 cycle AC. Thread tape as shown. Attach tape to take-up reel and drop into slot. Select track(s) to be used. Select tape speed and suitable equalization. Reset counter to "0000". Select input sources, plug into appropriate jacks, place Record-Play monitor switch in Record position, turn up appropriate level controls to obtain suitable mid-scale reading on appropriate meter, press Record and Play buttons simultaneously. Turning up the appro-

appropriate Play volume control(s) will allow the recording to be monitored. To monitor the tape the Record-Play monitor switch may be switched to the Play position. The meters on the recording channel(s) should not change their reading significantly and the sound should be the same in either position of the monitor switch. To play back recording: rewind tape, stop, and press Play button. Adjust Play volume controls to suit.

## CONTROLS AND FEATURES OF THE ROBERTS 400X

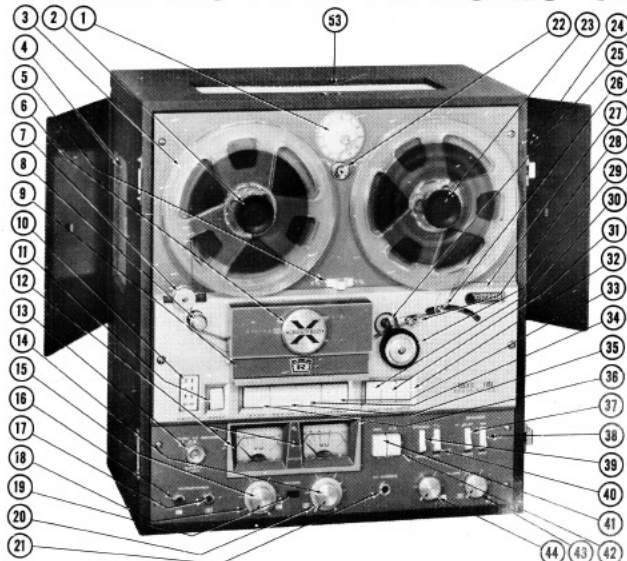

1. Automatic Replay Dial
2. Supply Reel Holder
3. Supply Reel
4. Left Speaker
5. Speed Selector
6. Track Selector
7. Tape Guide Roller
8. Dynamic Flutter Suppressor
9. Mute Control/Head Access
10. Remote Control Receptacle
11. Power On-Off Switch
12. VU Meters
13. Record Control & Safety
14. Right Mike Volume
15. Left Mike Volume
16. Left Mike Jack
17. Right Mike Jack
18. Left Line Volume
19. Record Indicator
20. Right Line Volume
21. Stereo Phone Jack
22. Automatic Replay Dial Defeat
23. Take-up Reel Holder
24. Right Speaker
25. Capstan
26. Automatic Tape Shut-Off
27. Counter
28. Tape Sensor
29. Pinch Wheel
30. Repeat Control
31. Reverse Control
32. "All-Off" Automatic Shut-Off Control
33. Fast Forward Control
34. Play/Start Control
35. Rewind Control
36. Stop Control
37. Bass Contour Selector
38. Speaker Mute
39. Stereo-Mono Output Selector
40. Playback/Record Equalization
41. Output/Record Button
42. Output/Playback Button
43. Right Channel Play Loudness
44. Left Channel Play Loudness
45. Line Input Left
46. Pre-amp/Line Output Left
47. Line Input Right
48. Pre-amp/Line Output Right
49. Right Speaker Output
50. Left Speaker Output
51. Reel Size Selector
52. Power Cord
53. Brake Adjustments

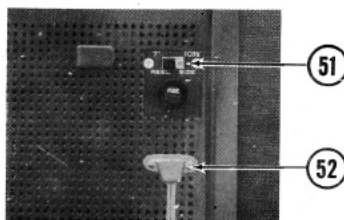
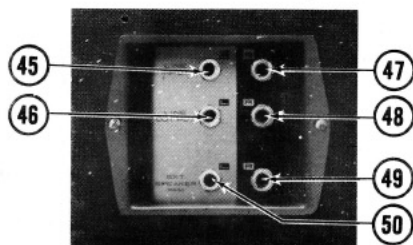

# BASIC RECORDING PROCEDURES, 400X

As operation of the 5000, 3190, and 400X is basically similar, only use of the dissimilar controls of the 400X will be covered below.

**1. Auto Dial** consists of three parts: The Stationary Marker, the pointer of which is the forward starting point for all automatic operations. The Rotating Pointer, the red arrow of which determines the stop and reverse position. The Moving Dial, the red line of which rotates during operation between the stationary pointer and the preset position of the red arrow on the Rotating Pointer.

**EXAMPLE:** Set the red line of the Moving Dial directly opposite the pointer of the Stationary Marker. Move the red arrow of the Rotating Pointer to any position around the dial. Press the Auto Control Button marked "Reverse", then press the "Play" Control Button. While the tape is playing in the forward direction, the red line of the moving dial will move until it reaches the red arrow of the Pointer. The tape will then stop and begin playing in reverse until the red line of the moving dial is back to the pointer of the Stationary Marker where, once again, the tape will stop and begin playing forward. This playing forward and playing in reverse will continue indefinitely until manually stopped.

Center Chrome Button will immediately activate the "Repeat" or "Reverse" action, depending upon which button has been depressed, without waiting for the red line of the moving dial to reach the rotating pointer.

**9. Mute Control** is used to remove the tape from the erase, record and play heads during fast forward or rewind. This eliminates wear which would result from fast motion of the tape across the heads.

**13. Record Button.** This control is inset in order to avoid unintentional operation which could erase a pre-recorded tape. The tape recorder must be in "play" mode before this button becomes operative. In order to prevent accidental record activation Button (13) is equipped with a safety lock. When you have established a recording condition the "RECORD" light (19) will be on.

**NOTE:** The 400X will not record if either the Repeat or Reverse is in.

**28. The Foil Tape Sensor** may be used in conjunction with the Automatic Replay Dial advantageously. The Auto Dial normally needs to be set at both starting and reversing points, usually requiring running the tape quickly through to the end and back again. If the tapes have previously been equipped with one-inch strips of metal-foil tape, on the reverse (shiny) side at the desired point of reversal, the only setting of the Auto Dial necessary is the zeroing of the outer ring to the black pointer and placing the red arrow sufficiently far counter-clockwise that it does not activate the Reverse Play or Repeat functions. (The red arrow must not be left on or near the black arrow, as this may cause erratic action of the Reverse Play and Repeat functions. Preferably place the red arrow to the white bar or Dial Off lettering.) Should 10½" reels of ½ mil tape be in use the Auto Dial will

not be able to be partially defeated by placement of the red arrow. In this case the Dial Defeat must be placed in the Dial Off position. The Foil Tape Sensor will still be able to activate Reverse Play at the end of the tape, or Rewind, and Auto Shutoff. However, there will be only one Reverse Play, as the tape will run off the end of the reel, as there is no provision for reversing directions and going into forward play again.

**30. Repeat Control.** The "Repeat" Button causes the tape to play forward, stop, fast rewind and play again, repeating the forward play over and over until manually stopped. The stop/rewind position is determined by the setting of the Auto Dial.

**31. The Reverse Control** causes the tape to play forward, stop, play in reverse, stop, play forward, etc., until manually stopped. The stop/reverse functions are controlled by the settings of the Auto Dial.

**NOTE:** Repeat button must be out for proper operation.

**NOTE:** When playing forward, the recorder is playing tracks #1 and #3. When playing in reverse, it is playing tracks #4 and #2. By using the reverse, it is not necessary to turn a reel of tape over to hear all four tracks.

**32. The Shut-Off Control** cancels the repeat or second reverse. Thus, if the Shut-Off Button is pressed at the same time as either the Repeat or Reverse, the tape will play forward, stop, and either play in reverse or rewind until the tape has run out causing the Auto Stop Lever to fall, shutting of the unit. If neither the Repeat nor the Reverse Button is in, the shutoff occurs at the end of the first pass when the tape runs off the reel.

**39. The Stereo-Mono Selector** disconnects the right channel input and output in Mono.

**41-42. Output.** When the Output "REC." button is pushed in the VU meters and the speakers are indicating what is going onto the tape. When the Output "P.B." button is in the VU meters and the speakers are indicating what is coming from the tape. When both buttons are out, channel transfer is possible. When both buttons are in, electrical echo is possible.

For channel transfer connect the microphone to the Left Mike input (16). Use the Left Mike volume control (15) to regulate the mike volume. The Left Line volume control (18) is used to regulate the transfer volume, and the Right Loudness Control (43) is used to regulate the monitor level. For echo, connect microphone(s). Use Line controls to regulate the amount of echo. There must be no plugs in the Line Input jacks when using either the transfer or echo functions.

## BASIC RECORDING PROCEDURES, 400X

Follow instructions given for the 5000 and 3190 series. In addition, be sure to raise the Mute Control/Head Access to place the tape in contact with the heads. Select either Stereo or Mono with the amplifier switch as well as with the Track Selector. Place Speaker switch in the On position in order to monitor or play back the recording.

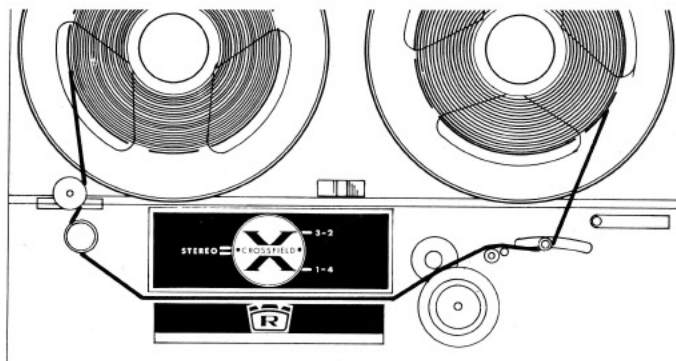

Thread tape on the 400X as shown in the diagram at right. (Lower Mute Control/Head Access before threading)

# TECHNICAL SPECIFICATIONS, 400X, 5000 AND 3190

## Power Requirement:

110-120V 60 cycle AC (standard).  
110-120V 50 cycle AC (optional).  
220-240V 60 cycle AC (optional).  
220-240V 50 cycle AC (optional).

## Power Consumption:

200 watts at maximum audio output;  
75 watts at normal listening levels. (400X and 5000X only.)  
90 watts maximum for all models without power amplifiers.

## Power Output:

34 watts peak power per channel, or over 10 volts RMS into an eight ohm resistive load, taken at 700 or 1,000 cps and before clipping. A test tape recorded at NARTB standard operating level of "0" db will drive amplifiers well beyond the clipping point at full volume. (400X and 5000X only)

## Preamp Output:

1-1½ volts into 15 K ohm load from "0" db. 700 or 1,000 cps reference tape. (Output meter indicates "0" db,  $\pm 1$  db.)

## Headphone Output:

8 ohm Z, pre-set level.

## Equalization:

NAB @ 7½ ips; EIA @ 3¾ ips.

## Bass Contour:

Power amplifiers flat or +5 to 10 db @ 100 cps.

## Record-Play Response:

$\pm 3$  db 25-22,000 cps @ 7½ ips;  $\pm 3$  db 30-17,000 cps @ 3¾ ips.

(Taken at -10 db from NARTB std. operating level)

## Bias Oscillator Frequency:

85 to 100 KC, all models except full track.  
60 KC, full track models.

## Erase Efficiency:

60 db.

## Signal-to-Noise Ratio:

50 db

## Crosstalk @ 1KC, Stereo:

-50 db

## Input Sensitivity:

Mike, 0.5 millivolt.  
Line, 50 millivolts.

## Timing Accuracy:

$\pm 0.5\%$ .

## Speed Regulation:

$\pm 0.05\%$  beginning to end of reel.

## Wow and Flutter:

0.12% @ 7½ ips.  
0.18% @ 3¾ ips.

## Operating Positions:

Vertical or horizontal.

## Quarter-track Head Impedances:

Bias and Erase, 750 ohms @ 90 KC.  
Record, 135 ohms @ 1 KC.  
Play, 1 K ohms @ 1 KC.

## Erase Voltage:

60-80 V.

## Bias Voltage:

30-50 V.

## Holdback Torque:

1¾-3½ inch-ounces, for 7" reels.

## Takeup Torque:

3-6 inch-ounces, for 7" reels.

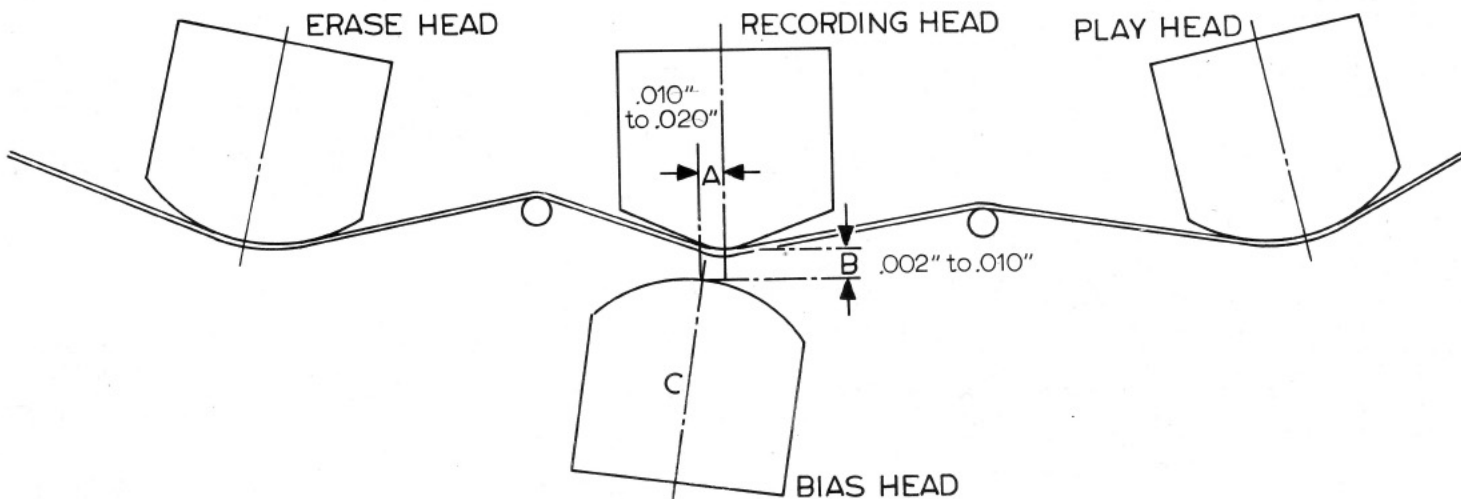

## HEAD ALIGNMENT

The positions of the heads relative to the tape are even more critical on the 400X, 5000 and 3190 than with regular machines due to the very small play head gap and the fact that these machines will record and playback at extremely high audio frequencies. Head alignment should be checked whenever there is a reduction in performance or whenever the head assembly has been disturbed.

The heads must be perpendicular with respect to the deck, as must all guides and posts. The tape must travel through the guides and over the heads without being subjected to forces which could cause the tape to travel irregularly and not contact the gap areas of each head completely. Thus, the tape should

enter the guide from the reel at the correct height. It should pass through each succeeding guide, whether in the record or play mode, without pressing against the top or bottom of any guide enough to cause the tape to buckle.

The quarter-track and half-track mono heads should be adjusted such that the edge of the upper channel gap area is just concealed by the upper edge of the tape. The half-track stereo and full-track heads should be centered on the tape. The gap area should be positioned well within the area of the head face which is contacted by the tape.

The play head azimuth should be checked after thoroughly demagnetizing and cleaning the heads and guides. Place a 15 KC

Ampex or Rheem alignment tape on the machine and adjust the play head azimuth for maximum output relative to 700 or 1,000 cps. Remove the reference tape and thread a blank tape. The record head azimuth and bias head position are checked while recording at 7½ ips a tone at -10 db from the NAB standard operating level. Monitor the playback with an AC VTVM. Record (while playing back) a 1,000 cps tone and set the level. Switch to 20 KC and adjust the record head azimuth for maximum output relative to the 1 KC level. Run a sweep from 30 cps to 22 KC. Response should be  $\pm 3$  db over the range. Allow  $\pm 5$  below 100 cps if necessary. If the frequency sweep is not satisfactory, the bias level should be checked. While recording and playing back 1 KC, adjust the bias head gap to within .001" from the tape and .010" (approximately) toward the supply side from the record head gap. Then adjust the head laterally along the tape to the point where the 1 KC signal is recorded at maximum amplitude. Adjust the record equalization pots for minimum 1 KC output (fully clockwise). Run another frequency sweep upward from 1 KC to 22 KC. A lack of high frequencies would indicate an over-biased condition or a defective component in the electronics, as the heads have already been cleaned and demagnetized and positioned correctly. While recording at 1 KC, reduce the bias by sliding the bias head further toward the supply side, away from the record gap. Do not reduce the bias enough to cause the 1 KC signal to decrease more than 2 db below its peak, as excessive noise and distortion will result. If the response does not meet specifications, check each step again. Head alignment is critical, as are clean heads and a good tape. Be sure that the response check is not being run at "0" db recorded level, as the high frequencies will suffer.

On machines with reverse play, adjust the right hand tape guide post (in reverse play) so that the tape enters the guide just to the right of the play head without distorting. Re-adjust takeup reel height in forward play if necessary. Adjust head height in reverse play to place the lower edge of the lower gap area just above or flush with the lower edge of the tape.

When removing either head assembly, unplug all cables and, on the 5000 and 3190, disconnect the red lead soldered to pin 4 of the oscillator jack coming from the record switch. Remove the plate mounting screws and withdraw the assembly from the deck.

## REMOVAL OF UNITS FROM CASE

When removing the 400X amplifier from the case, be sure to remove the screws in the bottom of the case. The amplifier will slide out easily. When removing the 400X deck, disconnect all cables to the deck before loosening the four screws in each corner of the deck plate (2 screws are under the lower deck cover), and the rear deck support. Support the deck securely as it is lifted from the case. Place deck upright on bench.

Before removing 5000 and 3190 deck, disconnect all cables accessible through rear access plate. When removing the 5000 and 3190 deck, lift only on the function buttons, headplate, reel tables, or frame. Place deck upside down (vertically) on bench.

## REMOVAL OF GLUED NUTS AND SCREWS

When replacing speakers, use a solvent such as methyl-ethyl-ketone or trichloroethane to dissolve the compound holding the nuts in place if the nuts will not back off without causing the screws to twist in the case. The same solvent may be used wherever a screw or nut has been cemented in place, if necessary.

## LUBRICATION OF DECKS

Lubricate bearing surfaces sparingly and only when necessary, to avoid the possibility of excess oil coming in contact with the tape. Use a high-quality lightweight machine oil.

## ADJUSTMENT OF CALIBRATION POTENTIOMETERS

The calibration pots (record equalization, record monitor/meter level, play monitor/meter level) are reached on the 400X by opening the lower access door. The pots are identified in the photos on page 11. The calibration pots on the 5000 and 3190 are reached through access holes in the amplifier chassis. Remove the power transistor (rear) vent panel to reach the holes.

The play level pots are set while playing a 700 or 1,000 cps tape recorded at "0" db. (NAB standard operating level.) Be sure that the equalization switch is in the correct speed before "zeroing" the meters to the lower end of the red line.

The record equalization pots are set, as mentioned in the head alignment section, for the flattest record-play frequency response. They affect the record level around and below 1 KC.

The record monitor/meter level pots must be set to within 1 db of the play monitor/meter level. Do this by recording 1 KC or 700 cps and monitoring the level in playback. Adjust the input to give a meter reading (in playback) of "0" db. Change the monitor switch to record and adjust the calibration pots for a "0" db or red line indication. This should be a final adjustment, as any other adjustments, except play level calibration, will change the calibration of the record monitor/meter.

## BRAKE ADJUSTMENT, 400X

The bands should be adjusted so that they just clear the drums with the solenoid energized. The springs should be tightened (counter-clockwise rotation) evenly and not beyond the point where the solenoid will not release the brakes when the line voltage drops to 90% of the minimum in the locality where the machine is to be used (usually 100 volts). If the brakes apply unevenly with equal spring tension, lightly buff the drums with fine sandpaper (#280 or finer) if cleaning the drums and bands with alcohol doesn't correct the situation.

## BRAKE ADJUSTMENT, 5000-3190

The rubber pads should be adjusted with an unworn portion rotated to contact the serrated disc edges. If the brakes apply unevenly, clean all friction surfaces with alcohol. If necessary, replace clutch springs and/or felt pads. Check linkage for binding. Brake clutch torque should be 15-30 inch-ounces.

## MOTOR SERVICE

It should be noted that the 5000 and 3190 motors are equipped with 220-240 volt windings, whereas the 400X has the standard 110-120 volt motors. The capstan motors run at full voltage. The reel torque motors run at full voltage only for rewind or fast forward. In the play mode, the reel torque motors run at reduced voltage, as shown on the schematics.

Removal of the 400X capstan motor is straightforward, requiring only the removal of the deck from the case and removal of the capstan motor and shaft casting assembly.

Removal of the 400X reel torque motor also requires the removal of the deck from the case. After removing the reel tables and reel table rings the motor mounting screws are accessible.

Removal of the 5000 and 3190 reel torque motors requires that the deck be removed from the case and that the reel tables and brake clutch assemblies be removed to gain access to the motor mounting screws.

Removal of the 5000 and 3190 capstan assembly requires that the deck be out of the case and the head assembly be removed, in order to gain access to the mounting bolts. The 5000 and 3190 capstan assembly need not be removed to change capstan shafts. (See note on page 12.)

## VOLTAGE CHART FOR MODELS 400X - 5000 - 3190

Caution: As with all solid-state equipment, the old-fashioned troubleshooting method known as "Probing with a Screwdriver for Sparks and Noise" is not recommended. A brief overload can permanently damage a transistor or diode. Use care and a meter or scope when obtaining first-hand information as to the performance of a circuit.

Amplifier Voltage Chart:  $\pm 10\%$  tolerance; 117 V 60 cycle line; machine in record mode; no signal. Reference to chassis ground. (Other important voltages are given on the schematics.)

Transistor	Collector	Emitter	Board	Pin	Voltage	
					Rec. Mode	P.B. Mode
Q101	-5.60 Volts	-0.60 Volts				
102	-3.80	-0.55	Rec Preamp	3	-18.0	-19.0
103	-11.5	-3.60	Rec Preamp	4	-12.5	0.00
104	-7.30	-3.30	Play Preamp	8	-19.0	-20.0
201	-6.50	-0.80	Power Amp, 400X only	10, 11, 15	-19.0	-20.0
202	-8.50	-1.00	Power Amp, 5000X only	15	-20.0	-21.0
203	-4.00	-0.60				
204	-12.5	-3.70				
401	-12.0	-1.60				
402	-17.5	-2.50				
403	-20.0	0.00 $\pm$ 0.10				
404	0.00 $\pm$ 0.10	+20.0				
601	-20.0	-4.00				
602	-20.0	-4.00				

Bias head voltage: 30 to 50 V @ 90 KC

Erase head voltage: 60 to 80 V @ 90 KC

### COMPONENT IDENTIFICATION PHOTOS

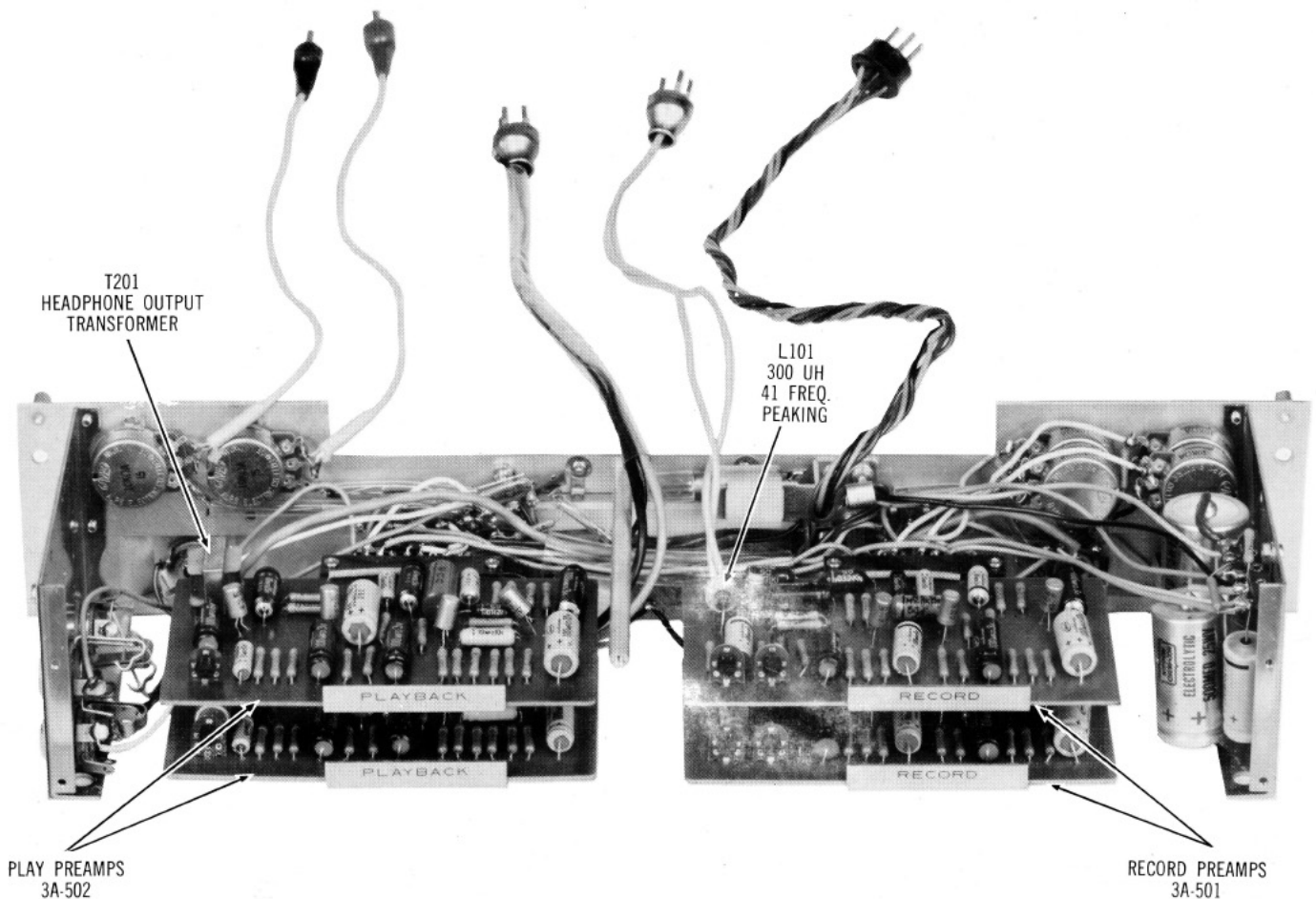

LOCATIONS OF CIRCUIT BOARDS IN 5000 AND 3190 PREAMP



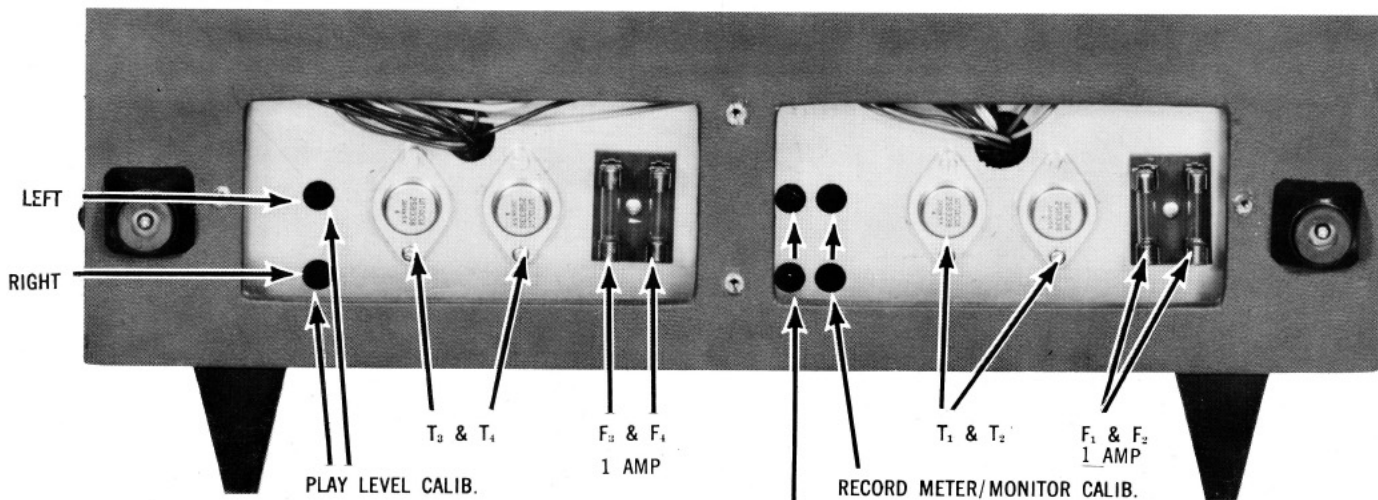

**LOCATION OF FUSES,  
POWER TRANSISTORS, AND  
CALIBRATION POTENTIOMETERS,  
5000-3190**

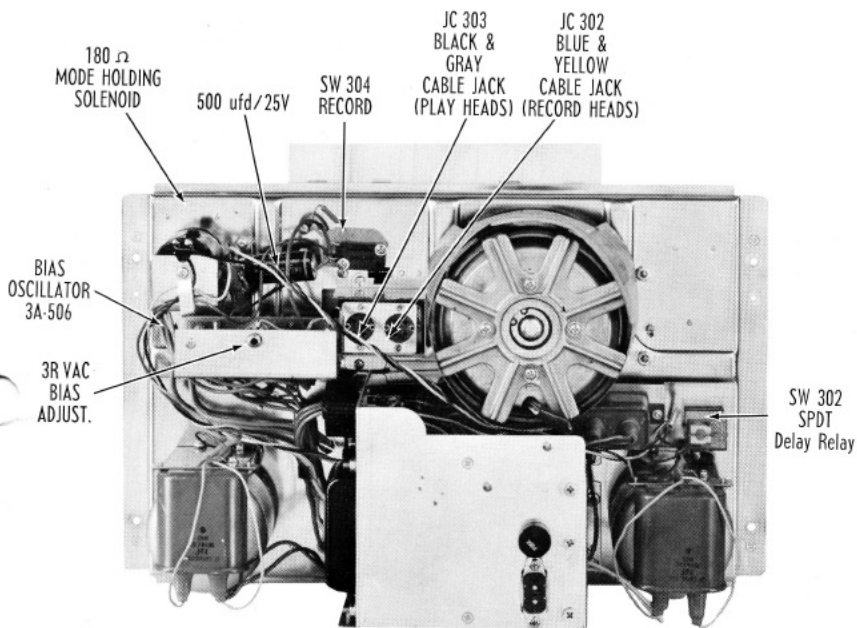

**LOCATION OF COMPONENTS  
ON REAR OF DECK, 5000-3190**

*RED PLUG  
YELLOW WIRE*

*BLACK PLUG  
BLUE WIRE*

**LOCATION OF POWER  
AMPLIFIERS, 5000X**

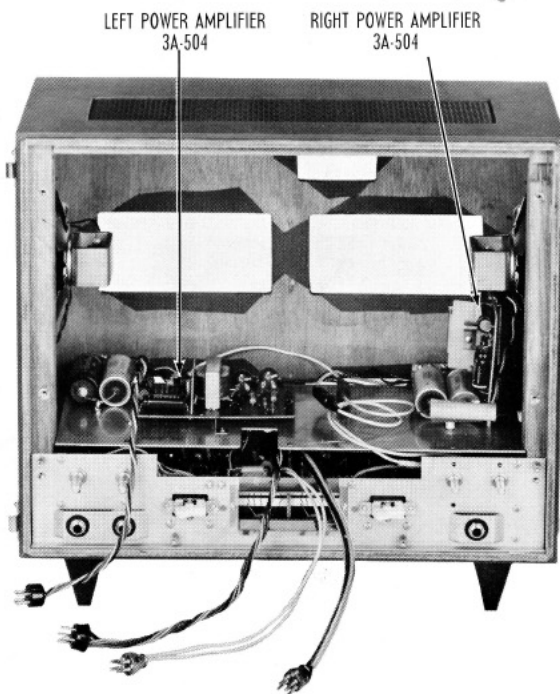

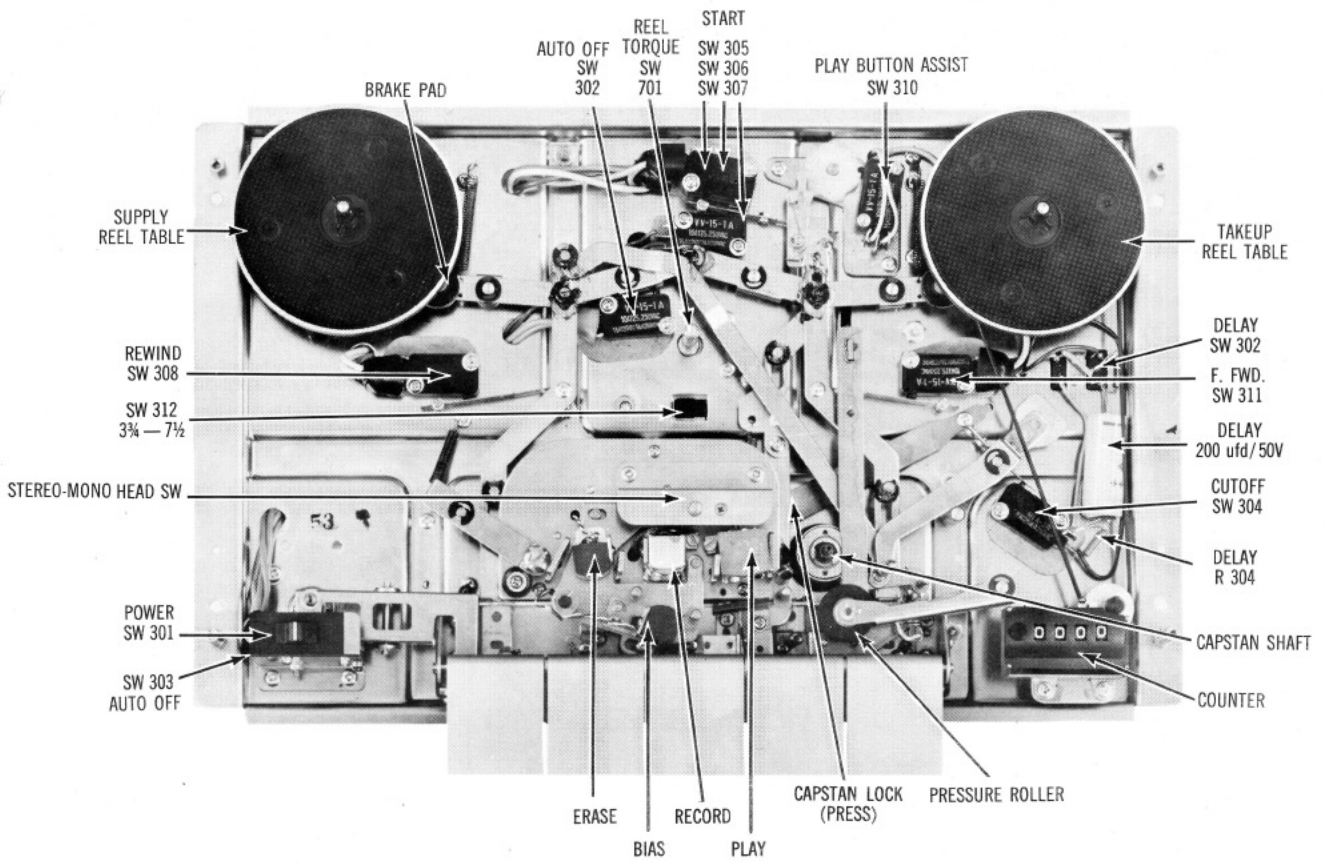

LOCATIONS OF COMPONENTS ON FRONT OF DECK, 5000-3190

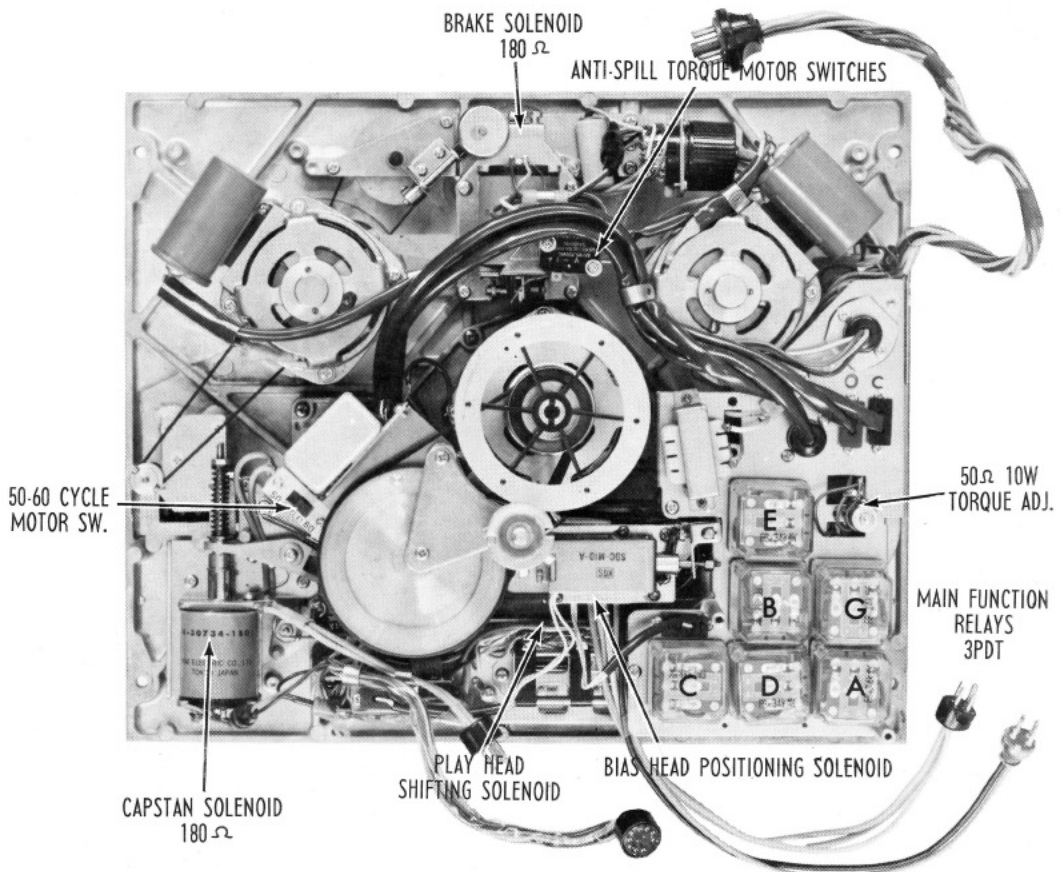

LOCATIONS OF COMPONENTS ON REAR OF DECK, 400X

PLAY LEVEL CALIB. 4PDT RECORD & AMPLIFIER REVERSE RELAYS

RECORD EQ. CALIB.

RECORD METER/MONITOR CALIB.

OUTPUT TRANSISTOR BALANCING POTS (ADJ. FOR 0.0 VOLTS ACROSS SPEAKER OUTPUT WITH NO AUDIO SIGNAL)

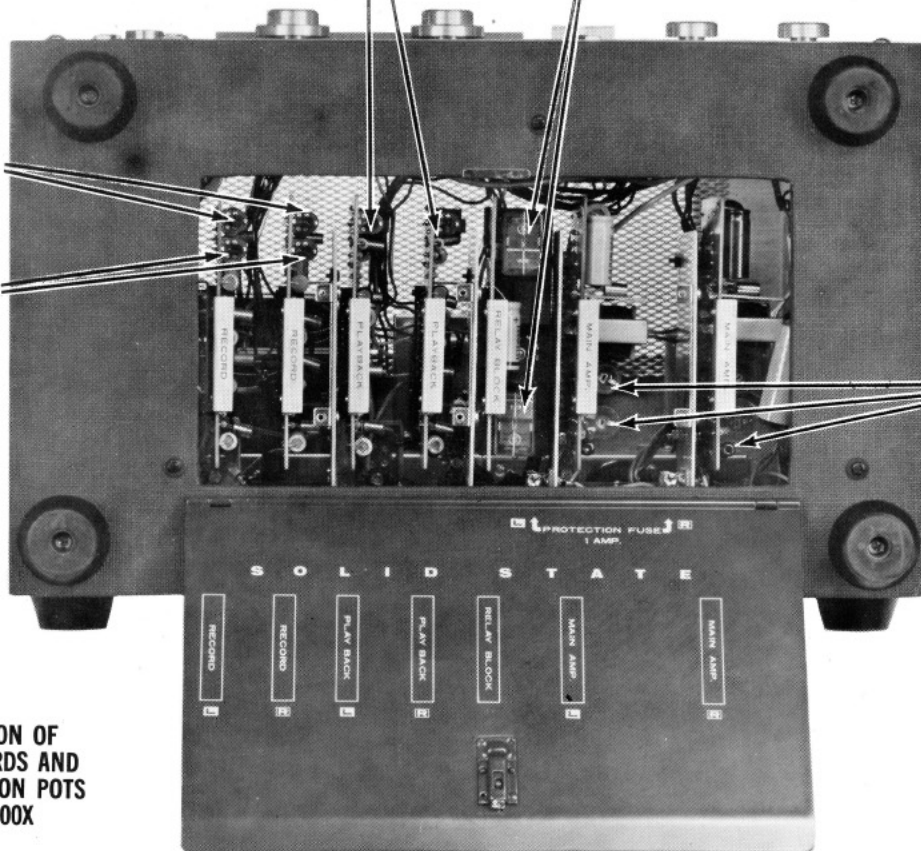

LOCATION OF P.C. BOARDS AND CALIBRATION POTS ON 400X

T 701

T 702

LOCATION OF 400X POWER SUPPLY IN TOP OF CASE

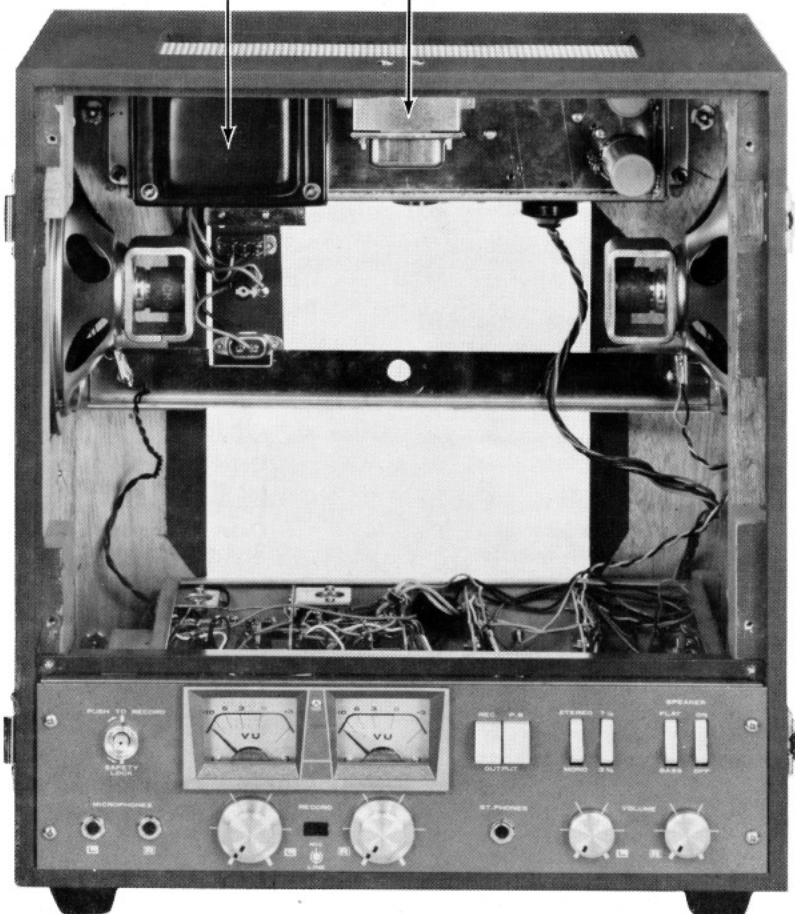

## CONVERSION TO 220-240 V

The 400X and 5000-3190 may be converted to operate from 220-240 V 60 cycle AC by changing the taps on the power transformer primary windings.

## CONVERSION TO 50 CYCLES

Conversion to 50 cycle operation is accomplished on the 400X by moving the drive belt to the larger diameter motor pulley and the smaller diameter capstan pulley. Reposition the belt guide so that when the motor is running, the belt is centered on the pulleys and in the slot in the guide. Slide both cycle switches to the 50 cycle position. (One on power supply, one on capstan assembly.)

Conversion to 50 cycle operation is accomplished on the 5000-3190 by replacing the standard capstan shaft with one having a larger diameter capstan. To replace shafts remove the upper head cover, press down on the flat bronze spring to lock the

flywheel, and unscrew the shaft. Do this in the horizontal position to prevent the flywheel from falling out of alignment when the shaft is withdrawn. The new shaft must be clean, free of burrs, and lightly lubricated before inserting. Install the "C" washer and thrust washer, taken from the old shaft, onto the new shaft. Tighten gently while holding flywheel lock down. Motor should coast slowly to stop from full speed when shut off. If not, the bearings are binding.

## CONVERSION TO 7½ - 15 ips

Conversion to 7½-15 ips operation is accomplished by changing the capstan diameter. A bushing is available for the 400X, which must be used with a smaller diameter pressure roller, Kit #63-99. A larger shaft must be installed on the 5000-3190 for the faster speeds. Specify if for 50 or 60 cycle operation when ordering. The use of 15 ips is recommended only for tape duplication or the playing of old tapes recorded at 15 ips, as the performance of these machines at 7½ ips is well in excess of professional audio studio requirements. See parts list for part numbers of capstan shafts.

# TROUBLESHOOTING THE RECORDER

(Unless noted otherwise, all symptoms and probable causes are applicable to all units.)

## SYMPTOMS AND PROBABLE CAUSE(S):

### Nothing goes —

- Blown fuse.
- Open transformer.
- Loose plug, wire, or cold solder joint.
- Defective switch.

### Motor doesn't go —

- Open transformer or resistor.
- Loose plug, wire, or cold solder joint.
- Defective motor capacitor.
- Defective relay or switch.
- Shaft not free to turn.
- Open motor winding.

### Reel motors don't go —

- Tape tension (reel torque) selector switch between positions.

### Motor overheats —

- Shaft binding.
- Unit not wired for correct voltage.

### Transformer overheats —

- Unit not wired for correct voltage.

### Blows fuses —

- Shorted winding in transformer.
- Shorted winding in motor.
- Shorted motor capacitor.
- Shorted diode.
- Shorted filter capacitor.
- Unit not wired for correct voltage.
- Line-to-line short.
- Line-to-chassis short.

### Slow or No F. Fwd. or Rewind —

- Brakes not releasing completely.
- Defective relay or switch.
- Loose plug, wire, or cold solder joint.
- Switch linkage not adjusted.

### Brakes do not apply quickly from F. Fwd. or Rewind, 400X —

- Switches on brake solenoid not adjusted to open just before lever reaches bottom stop as solenoid is de-energized.

### Brakes uneven, too slow, or too sudden, 400X —

- Dirty or excessively polished brake drums.
- Dirty or excessively worn brake bands.
- (Clean surfaces with alcohol, buff drums lightly with fine sandpaper. Touch drums with extremely small quantity of silicon grease if grabby.)

### Brakes uneven, too slow, or too sudden, 5000 and 3190 —

- Dirty or excessively worn brake clutch pad and disc.
- Weak clutch pressure spring.
- Rubber pads worn excessively.
- Linkage binding.
- (Clean surfaces with alcohol, rotate rubber pads to unused portion and re-tighten.)

### Brakes don't release —

- Linkage binding.
- Solenoid not actuating, 400X.
- Bands too tight, 400X.

### No Repeat or Reverse, 400X —

- Defective relay or switch.
- Loose wire, plug, or cold solder joint.
- Foil tape sensor post not contacting foil.
- Defective diode on Auto Function switch board.
- Broken dial drive belt.

### No delay when entering or leaving reverse play or when entering forward play automatically, 400X —

- Defective relay or delay capacitor.
- Defective diode on relay board in amplifier.
- Loose wire, plug, or cold solder joint.

### Start button hard to press, 5000 and 3190 —

- Open solenoid winding.
- Loose plug, wire, or cold solder joint.
- Defective power supply.
- Gear switch not adjusted to close when start button is about ½ way down and open when button is fully down.

# TROUBLESHOOTING (Continued)

## SYMPTOMS AND PROBABLE CAUSE(S):

### Counter doesn't go, or sticks —

Belt broken or off pulleys.  
Grease on belt or pulleys.  
Counter shaft binding.  
Pulley loose.  
Defective gear rack in counter (caused by operator not re-setting to "0000" when pushing button and not insuring that button returns fully).

### Deck functions erratically —

Switch not adjusted.  
Loose plug, wire, or cold solder joint.  
Defective relay or switch.  
455 type remote control attached to 400X.

### Will not remain in play mode, 5000 and 3190 —

200 mfd delay capacitor defective.  
Reel torque insufficient.

### Will not remain in any mode, 5000 and 3190 —

Open solenoid.  
Defective power supply.  
Bent or broken spring on cutoff arm.  
Defective relay.  
Linkage not adjusted.

### Will not enter any mode, 400X —

Defective cutoff switch or lever.  
Defective relay or power supply.

### Transport clicks in play, tape doesn't move at all or moves very short distance, 400X —

Auto Function button in and red arrow and zero both at or near bottom pointer. (Re-locate dials.)

### Excessive wow and flutter —

Dirty or excessively worn heads, tape guides, capstan, pressure roller.  
Stretched tape.  
Bearing rough or binding.  
Bent shaft.  
Brakes dragging.  
Excessive holdback torque.  
Oil on drive surfaces.  
Flywheel loose.  
Drive belt rubbing guide, stretched, dirty, cracked, or twisted, 400X.

### Tape squeals in play or record —

Dirty or excessively worn heads.  
Excessive holdback torque.  
Low-quality or worn-out tape.

### Heads wear rapidly and/or become coated with oxide rapidly —

Excessive holdback torque.  
Low quality non-lubricated tape.

### Sound is backwards, 400X —

Playhead not dropping into or out of reverse play position properly.

### No output —

Monitor switch incorrectly positioned.  
Defective power supply or amplifier.  
Loose plug, wire, or cold solder joint.  
Mute switches not opening (on pressure roller arm), 400X.  
Head cover not pushed fully closed, 400X.

### Distorted and/or low output —

Dirty or excessively worn heads.  
Head alignment incorrect.  
Magnetized heads.  
Oxide (dull) side of tape not facing play head.  
Insufficient holdback torque.  
Excessively worn tape.  
Defective amplifier or power supply.

### Distorted or No output from speaker(s) only, line output OK —

Amplifier fuse(s) open in one or more power supply leads to output transistor(s).  
Defective speaker or series resistor.  
Defective amplifier or power supply.  
Loose plug, wire, or cold solder joint.

### Distorted and/or low record —

Bias level not optimum.  
Bias head not moving completely into position in record mode.  
Magnetized, excessively worn, or dirty heads.  
Defective amplifier or power supply.  
Excessively worn tape.  
Head alignment incorrect.  
Insufficient holdback torque.  
Bias waveshape not symmetrical.

### No record —

No bias.  
Defective relay or switch.  
Loose plug, wire, or cold solder joint.  
Defective amplifier or power supply.  
Record button lock not released, 400X.  
Repeat or Reverse button in, 400X.

### Erase noisy or insufficient —

Magnetized, excessively worn or dirty heads.  
Head alignment incorrect.  
Excessively worn tape.  
Bias level too low.  
Bias waveshape not symmetrical.

### No channel transfer, 400X —

Plug in left line input jack.  
Amplifier Stereo-Mono switch not in Stereo.  
Head switch not in Mono.  
Both Monitor buttons not out.  
Left Line Input control down.  
Defective switch or left line input jack.

### No echo, 400X —

Plugs in line input jacks.  
Both monitor buttons not in.  
Line input control down.  
Defective switch or line input jack.

### No record in mono —

Defective head switch or cam.  
Heads interchanged left for right.  
Not using left inputs and controls.

### Hum or crackly noises in record and/or play —

Loose plug, wire, or cold solder joint.  
Wires rubbing motor, flywheel, or belt.

### Oscillation at high level settings —

Loose plug, wire, or cold solder joint.  
Leads need dressing away from amplifiers.

### Meter doesn't indicate, record and play normal —

Loose wire or cold solder joint.  
Defective meter rectifier or resistor.  
Open meter winding.

### Meter level not same in record as in play when recording —

Dirty heads.  
Excessively worn tape.  
Equalization switch not set correctly.  
Record meter/monitor pot not calibrated after readjusting bias or record E Q pot.

### No input from mike and/or no output to headphones —

Phone plugs have large diameter shells. Use newer, smaller, shell plugs which do not hit panel before snapping into jacks, 5000, 3190.  
Defective jack or amplifier.  
Loose plug, wire, or cold solder joint.

## PARTS LIST FOR THE ROBERTS 400X, CALIFONE 3190, ROBERTS 5000.

Description	Part Number 400X	Part Number 5000 3190	Description	Part Number 400X	Part Number 5000 3190
<b>Assemblies:</b>					
Head, complete, ¼ tr. stereo	88-942	88-941	Screw, deck cover 4 X 4 mm	88-785	
Oscillator 3A-506	88-757	88-757	Screw, head cover, 3 X 36 mm		88-894
Power Amplifier 3A-504	88-758	88-758	Screw, amp panel, 2 X 6 mm		88-893
Play Preamp 3A-502	88-759	88-759			
Record Preamp 3A-501	88-760	88-760			
Relay Board, Function	88-761		Shroud, case foot		3-342-1
Relay Board, Record & Amp. Rev. 3A-503	88-762		Spring, coil, brake clutch pressure		88-896
Replay Mechanism	88-768		Spring, flat, gate positioning	88-786	
Roller, Impedance (flutter suppressor)	88-763		Spring, flat, shutoff sw. actuating		88-897
Switches, Auto Function 3AF	88-764		Spring, flat, motor speed sw. actuating		88-898
Switches, Monitor 3A-505	88-765				
<b>Bands, Brake</b>	88-108		Standoff, deck plate spacing	88-787	88-899
<b>Bearings:</b>			Washer, "C", brake clutch retaining		88-900
Capstan end thrust (ball)	88-585		Washer, plastic, brake clutch spacing		88-901
Capstan (sleeves in casting)	40-15N				
Tape guide (ball & race)		62-87-3	<b>Heads:</b>		
Torque motor (ball & race)	88-740	88-740	¼ track stereo bias	88-788	88-788
			¼ track stereo erase	88-792	88-792
			¼ track stereo play	88-796	88-796
			¼ track stereo record	88-800	88-800
			½ track stereo bias		88-789
			½ track stereo erase		88-793
			½ track stereo play		88-797
			½ track stereo record		88-801
			½ track mono bias		88-790
			½ track mono erase		88-794
			½ track mono play		88-798
			½ track mono record		88-802
			Full track bias		88-791
			Full track erase		88-795
			Full track play		88-799
			Full track record		88-803
<b>Belts:</b>			<b>Inductors — See Transformers and Inductors</b>		
Auto dial (replay)	88-584		<b>Jacks:</b>		
Counter	88-111	88-878	2 cond, phone w/N.C. contact	29-7260	29-7260
Main drive (capstan)	63-009		2 cond, phono pin, line type	88-804	88-804
			2 pin, motor and solenoid	88-086	88-086
			3 cond, phone (stereophone)	29-7315	29-7315
			3 pin, one large		88-902
			4 pin, one large, square	88-680	88-680
			4 pin, one long space	29-7351	29-7351
			4 pin, one large, radius	88-805	
			5 pin, two long spaces		88-903
			6 pin, two large (std. tube)	88-806	88-806
			8 pin, keyway (octal)	88-678	
			8 pin, rect. (remote)	63-68	
			8 pin, rect. (relay)		88-904
			9 pin, keyway	88-675	
			9 pin, miniature (P.C. type)	29-7334	
			10 pin, P.C.B.	88-807	88-807
			11 pin, keyway (relay)	88-106	
			14 pin, rect. (relay)	88-112	
			18 pin, P.C.B.	88-808	88-808
			22 pin, P.C.B.	88-809	
			Fuse clip, dual	88-810	88-810
			Fuse post	29-7349	29-7349
			Pilot lamp socket	88-562	88-562
			<b>Jewel, record indicator</b>	88-343-1	
			<b>Kit, 15 ips conversion</b>	63-99	
			<b>Knobs:</b>		
			Amplifier, inner dual	88-811	88-905
			Amplifier, outer dual	88-812	88-906
			Amplifier, single	88-811	88-907
			Auto Replay, inner plastic	88-813	
			Auto Replay, outer dial	88-814	
			Head switch	88-815	88-908
			Power switch	88-770	88-909
			Record lock/shield	88-816	
			Reel torque		88-910
			Speed	88-817	88-911
			<b>Lamp, pilot</b>	88-509	88-509
<b>Cap, pressure roller</b>	88-754				
<b>Cap, reel</b>	88-518				
<b>Case, less speakers</b>	88-772	88-881			
<b>Case, 5000 Mono</b>		88-881-1			
<b>Cord, power</b>	27-335	27-335			
<b>Counter, 4 digit P.B. reset</b>	88-94	88-94			
<b>Cover, head, upper</b>	88-774	88-883			
<b>Cover, head, lower</b>	88-773	88-882			
<b>Cover, head, lower, 3190</b>		88-882-1			
<b>Drum, brake, supply</b>	88-617				
<b>Drum, brake, takeup (with pulleys)</b>	88-618				
<b>Escutcheon, jack panel</b>	88-778	88-887			
<b>Escutcheon, meter</b>	88-775	88-888			
		(2 pcs.)			
		88-888-1			
		(2 pcs.)			
<b>Fan, plastic</b>	88-776				
<b>Flywheel, capstan</b>	88-830	88-884			
<b>Fuse, 1 amp</b>	88-777	88-777			
<b>Fuse, 2 amp</b>		25-103-1			
<b>Fuse, 3 amp</b>	25-103-4				
<b>Gear, plastic, sw. actuating</b>		88-885			
<b>Hardware:</b>					
Bushing, 15 ips	63-97				
Catch, lid, 2 pcs.	88-734-1	88-886			
Can, felt pad		88-717			
Foot, rubber post		88-940			
Foot, case	88-779	3-316			
Handle, case		88-889			
Hinge, case, 2 pcs.	88-297	88-891			
Ramp, power sw. actuating		88-892			
Ring, reel table	88-780				
Screen, speaker	88-782	88-890			
Screen, vent	88-783				
Screw, 15 ips bushing	63-98				
Screw, reel table	88-707	88-895			
Screw, amp mounting 4 X 25 mm	88-784				
Screw, deck mounting 4 X 20 mm	88-671				

## PARTS LIST (Continued)

Description	Part Number 400X	Part Number 5000 3190	Description	Part Number 400X	Part Number 5000 3190
<b>Levers (Arms):</b> Felt pad Pressure roller	88-706	88-913	<b>Switches:</b> SPST, micro, MLA-20 (shutoff only) SPST, power SPST, leaf (mute) SPST, record	13-998 88-841 88-688	88-935
Shutoff, front Shutoff, rear Tape guide, supply	88-818 88-819 88-820	88-912	SPDT, micro, rectang. actuator SPDT, micro, round actuator, VV-15 DPDT, pushbutton DPDT, slide DPDT, rocker	88-71 88-842 13-965 88-843	88-842 840-121 88-843
<b>Lock, reel</b>	88-518	88-914	DP4 pos, rotary 4PST, rocker, special grounding 4PDT, pushbutton — See Assemblies 6PDT, slide	88-844 88-687	88-936 88-844 88-687
<b>Meter, VU</b>	88-821	88-915	<b>Table, reel</b>	88-781	88-937
<b>Motor, capstan</b>	88-822	88-916	<b>Semiconductors:</b> <b>Diodes:</b> SL-150 avalanche SPN-01, full wave, encapsulated SW-05, power diode 12GZ, dual (separate) encapsulated 1N34A, meter diode	88-831 88-832 88-125 88-833	88-831 88-832 88-125 88-833 66-6029
<b>Motor, takeup</b>	88-643-1	88-918	<b>Thermistors:</b> 13D27	88-834	88-834
<b>Motor, supply</b>	88-642-1	88-917	<b>Transistors:</b> 2SB75(A) 2SB75(B) 2SB338(A) 2SB370(A) 2SB370(B) 2SB443(A)	88-835 88-540 88-536 88-836 88-837 88-838	88-835 88-540 88-536 88-836 88-837 88-838
<b>Pad, felt, tape cleaning</b>		88-718	<b>Transformers and Inductors:</b> Autotransformer, reel motors Choke, 0.3 hy. 0.1 amp Coil, bias adjust. (L601) Coil, peaking, 300 uh (L101)	88-845 88-846 88-847 88-848	
<b>Pad, felt, brake</b>		88-880	Transformer, bias oscillator (T601) Transformer, driver (T301) Transformer, headphone output (T201) Transformer, power	88-849 88-850 88-851 88-852	88-849 88-850 88-851 88-938
<b>Plates:</b> AC/Fuse cover Amplifier front panel Amplifier front panel, 3190 Mono Deck cover Jack panel, line	88-823 88-825 88-824	88-919 88-920 88-920-1 88-921 88-923	<b>Capacitors:</b> 1000 mfd @ 25 V 500 mfd @ 50 V can 500 mfd @ 50 V, wire leads 500 mfd @ 25 V 500 mfd @ 6 V		<b>Part Number</b> 14-783 88-702 14-782 14-790 14-721
Jack panel, speaker Rear access Rear vent Speaker cover	88-091 88-826	88-922 88-924 88-925	200 mfd @ 50 V 200 mfd @ 25 V 100 mfd @ 10 V 100 mfd @ 3 V		88-853 14-800 14-773 14-788
<b>Plugs:</b> 2 pin, AC interlock 2 pin, motor and solenoid 2 cond, phono pin 3 pin, one large	29-7347 88-085 40-5021	29-7347 88-085 40-5021 88-902-01	50 mfd @ 50 V 50 mfd @ 25 V 50 mfd @ 10 V 30 mfd @ 3 V		14-770-1 14-784 14-774 88-407
4 pin, one large, square 4 pin, one large, radius 4 pin, one long space 5 pin, two long spaces	29-7345 88-805-01 29-7247	29-7345 88-903-01	10 mfd @ 25 V 10 mfd @ 10 V 3 mfd @ 300 VAC 1.8 mfd @ 350 VAC 1.5+1.5+1.0+1.0 mfd @ 300 VAC		88-856 88-569 88-854 88-855 88-601
6 pin, two large 8 pin, keyed 8 pin, remote 9 pin, keyed 9 pin, miniature 22 pin P.C.B.	88-806-1 88-652 63-06 88-651 88-650 88-809-01	88-806-1	0.5 mfd @ 350 V 0.22 mfd @ 50 V 0.1 mfd @ 350 V 0.1 mfd @ 50 V 0.068 mfd @ 100 V		14-795 14-778 14-743 14-764 88-857
<b>Posts:</b> Foil tape sensor Tape guide, right	88-828 88-829		0.047 mfd @ 50 V 0.033 mfd @ 50 V		14-765 14-746
<b>Pressure roller, standard</b>	88-148	66-6002			
<b>Pressure roller, 15 ips</b>	63-96				
<b>Printed circuits — See Assemblies</b>					
<b>Pulleys:</b> Capstan Counter Reel motor Drive motor	88-830 88-656 40-14N	88-927 88-926			
<b>Relays:</b> SPDT miniature 3PDT function 4PDT miniature	88-096 88-097	88-928			
<b>Shafts:</b> Capstan, 3¾-7½ ips 60 cps (std) Capstan, 3¾-7½ ips 50 cps Capstan, 7½-15 ips 60 cps Capstan, 7½-15 ips 50 cps Pressure roller	88-839 88-830 88-931 88-932 88-840	88-929 88-930 88-931 88-932 88-933			
<b>Sockets — See Jacks</b>					
<b>Solenoids:</b> 60 ohm, play button assist 180 ohm, general purpose Head positioning	88-528 88-543	88-934 88-528			
<b>Speaker</b>	88-526	88-46-1			

## PARTS LIST (Continued)

Description	Part Number	Description	Part Number
0.02 mfd @ 400 V	14-741	300 ohm 1/2 w	5-536
0.015 mfd @ 50 V	88-858	470 ohm 1/2 w	5-604
0.01 mfd @ 400 V	14-720	560 ohm 1/2 w	5-587
0.001 mfd @ 350 V	14-719	680 ohm 1/2 w	5-617
470 pfd	14-713	820 ohm 1/2 w	88-862
330 pfd	14-711	1.0 K ohm 1/2 w	5-550
<b>Resistors:</b>		1.2 K ohm 1/2 w	5-590
0.2 ohm 2 w	88-665	1.5 K ohm 1/2 w	5-623
0.5 ohm 1 w	5-631	1.8 K ohm 1/2 w	5-557
8 ohm 5 w	5-534	3.0 K ohm 1/2 w	5-588
8 ohm 15 w	88-870	3.3 K ohm 1/2 w	5-540
12 ohm 1/2 w	88-859	5.6 K ohm 1/2 w	5-607
24 ohm 10 w	88-869	6.8 K ohm 1/2 w	5-509
36 ohm 1 w	88-865	10 K ohm 1/2 w	5-567
47 ohm 1/2 w	5-608	15 K ohm 1/2 w	5-616
50 ohm 5 w	88-867	18 K ohm 1/2 w	88-864
50 ohm 10 w adj.	88-868	20 K ohm 1/2 w	5-526
68 ohm 1/2 w	5-524	22 K ohm 1/2 w	5-526
82 ohm 1/2 w	88-860	30 K ohm 1/2 w	5-541
100 ohm 1/2 w	5-530-1	39 K ohm 1/2 w	5-508
100 ohm 2 w	5-511	47 K ohm 1/2 w	5-560
100 ohm 5 w	5-576	100 K ohm 1/2 w	5-517
120 ohm 2 w	88-862	10 K ohm dual pot	88-871
150 ohm 1/2 w	5-625	10 K ohm single pot	88-872
200 ohm 1/2 w	5-577	300 ohm wafer pot	88-876
220 ohm 1/2 w	5-577	500 ohm wafer pot	88-875
270 ohm 1/2 w	5-619	10 K ohm wafer pot	88-873
		20 K ohm wafer pot	88-874

**WHEN CORRESPONDING WITH THE FACTORY REGARDING PARTS, INCLUDE THE RECORDER MODEL, THE PART NAME, THE PART NUMBER, AND A DESCRIPTION OF APPLICATION WHENEVER POSSIBLE IN ORDER TO INSURE RAPID AND ACCURATE FILLING OF YOUR ORDER. ADDRESS PARTS ORDERS TO:**

**CALIFONE-ROBERTS, Parts Dept.  
5922 Bowcroft Street  
Los Angeles, Calif. 90016**

**CALIFONE-ROBERTS ELECTRONICS DIVISION** RHEEM MANUFACTURING CO., LOS ANGELES, CALIFORNIA 90016



THE RHEEM POLICY IS ONE OF CONTINUAL DEVELOPMENT AND IMPROVEMENT. FOR THAT REASON, RHEEM RESERVES THE RIGHT TO CHANGE SPECIFICATIONS WITHOUT NOTICE, AND WITHOUT INCURRING ANY OBLIGATION RELATING TO MODELS PREVIOUSLY MANUFACTURED BY THEM.



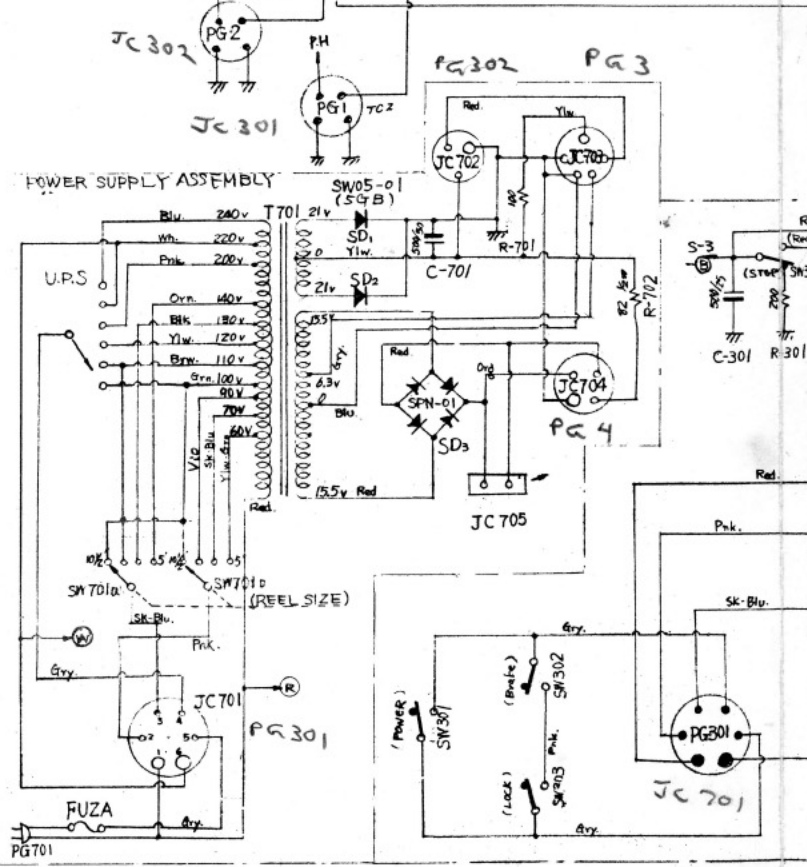
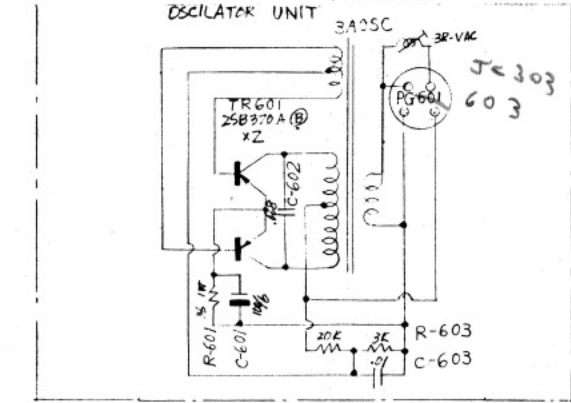
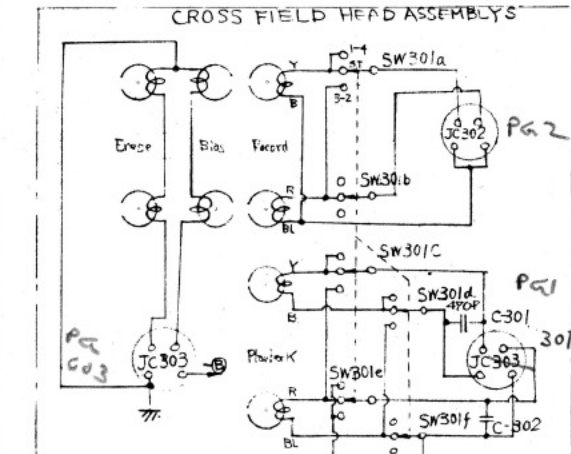
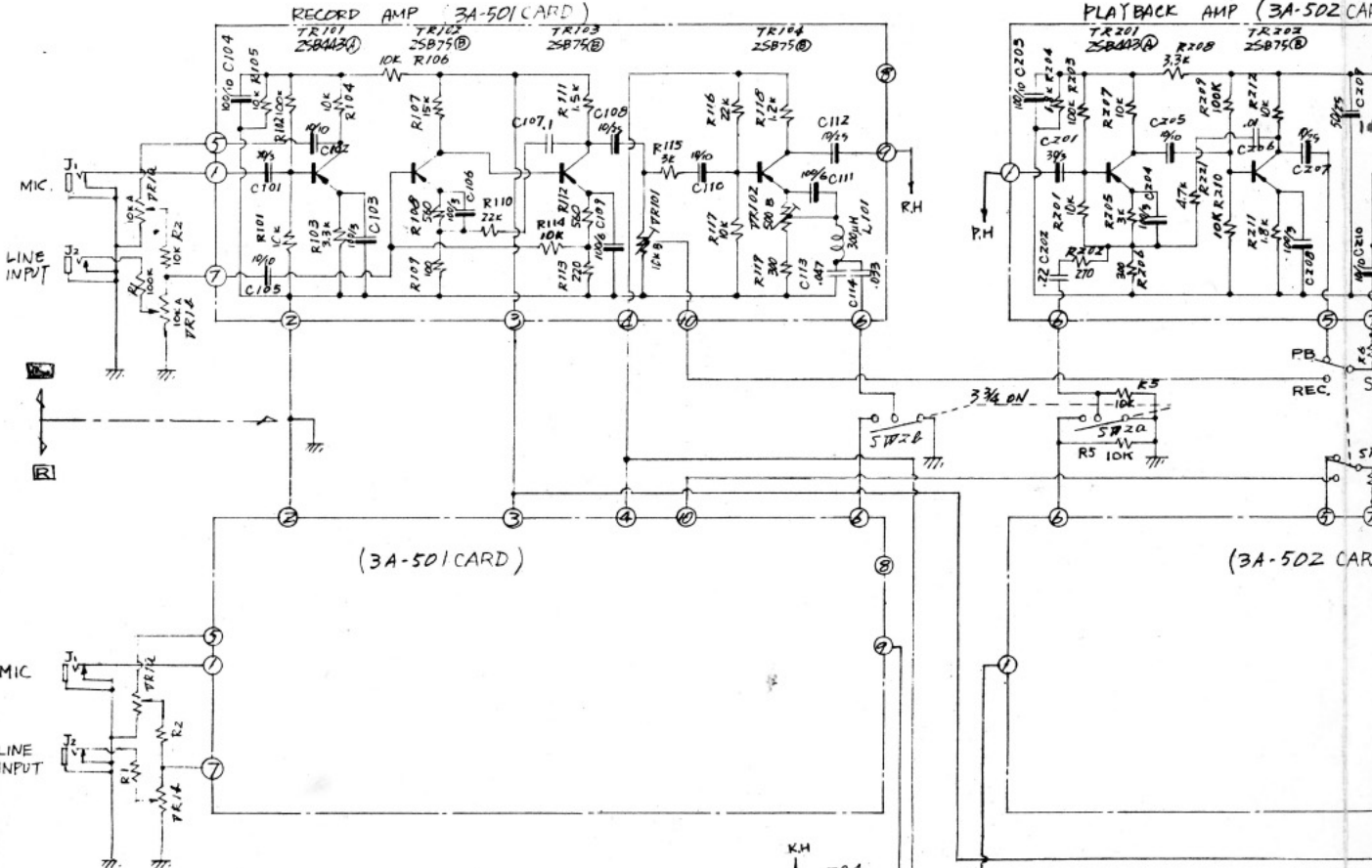

[TRACK SELECTOR]

[REEL SIZE]

[POWER SW]

[RECORD]

A-502 CARD)

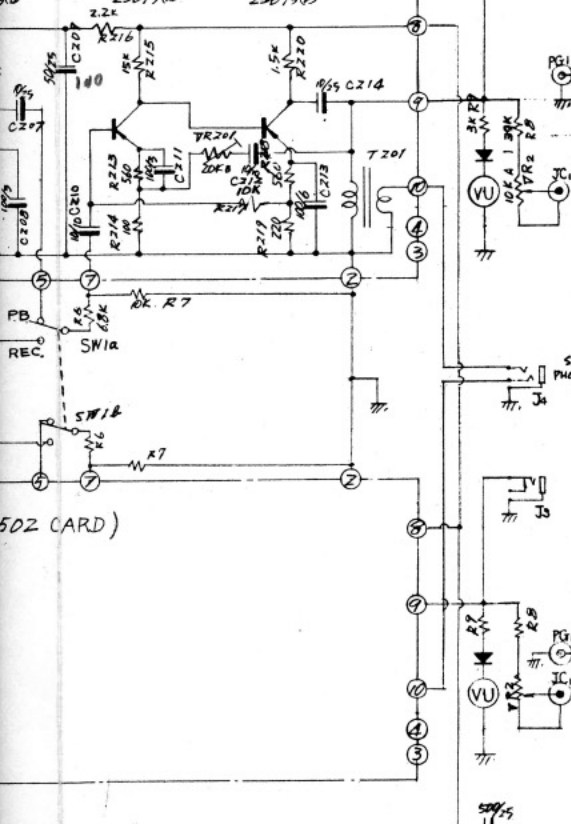

502 CARD)

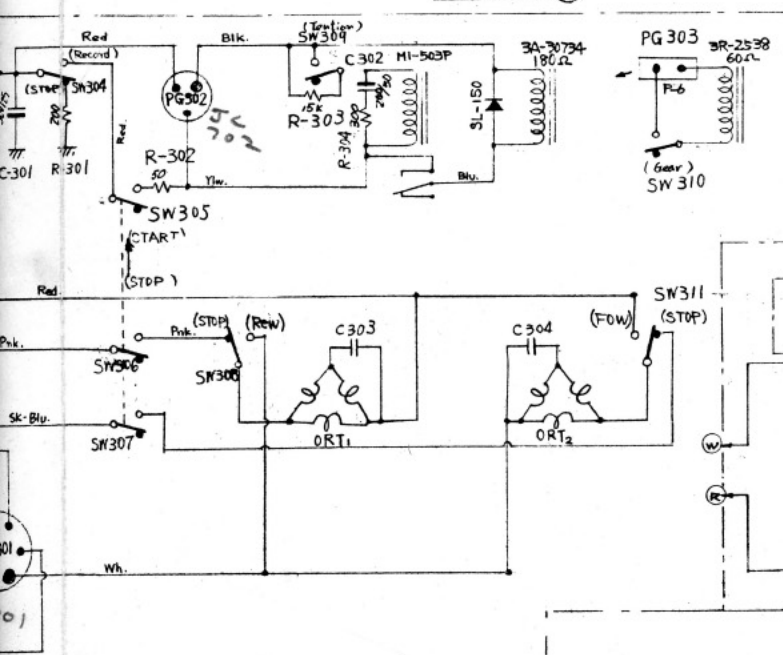
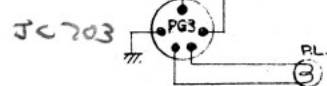
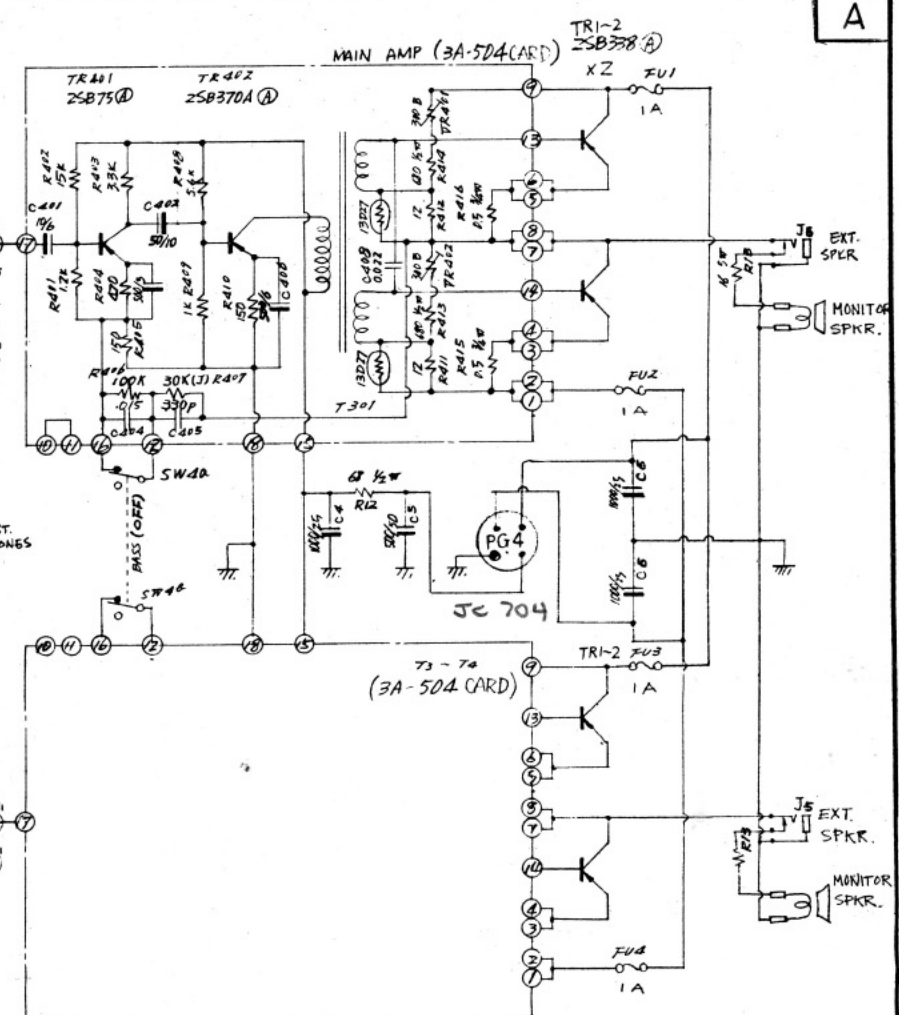

AMPLIFIER MECHANISM

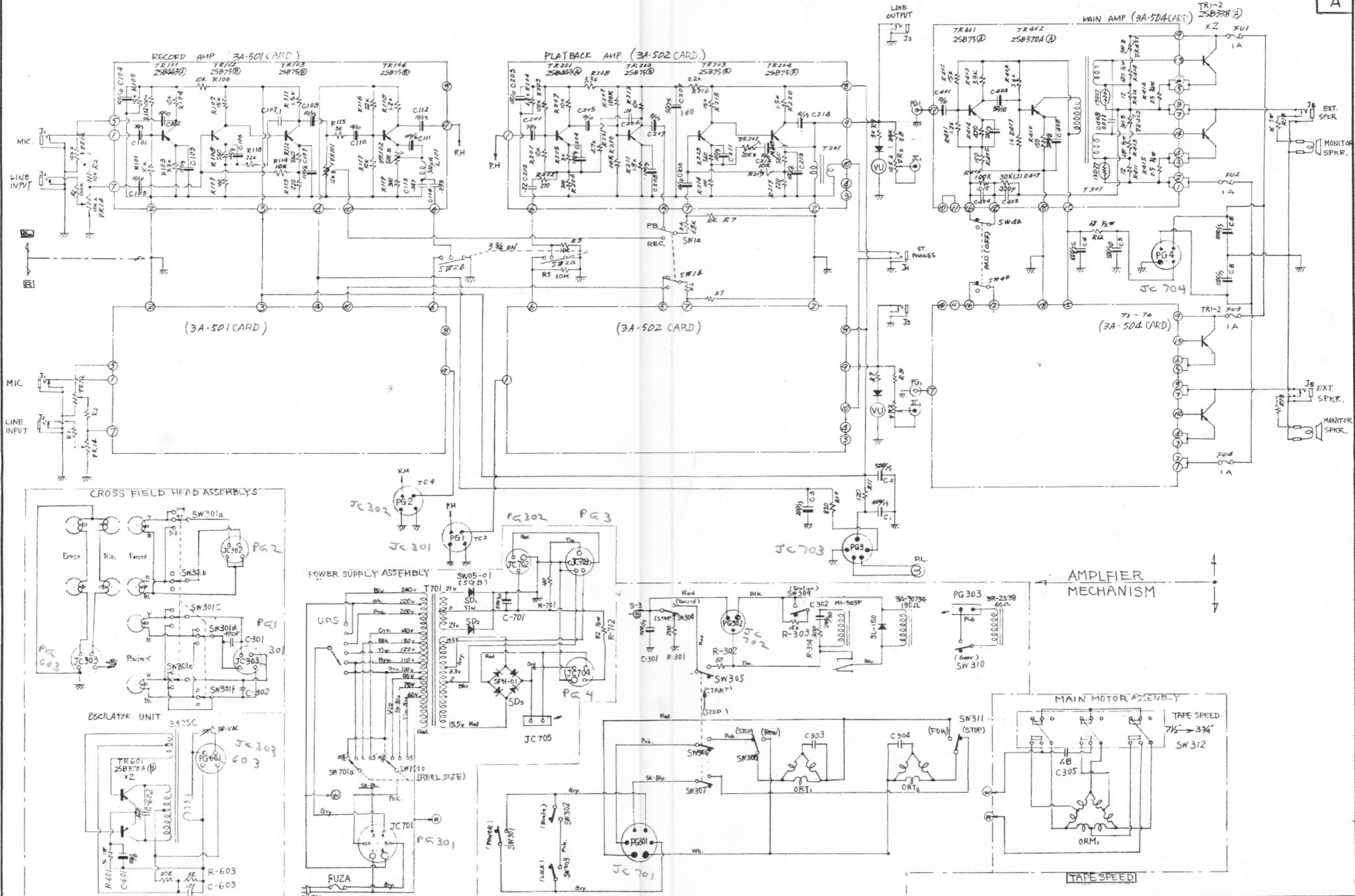

[TRACK SELECTOR]

[REEL SIZE]

[POWER SW]

[RECORD] [START] [REWIND] [FORWARD]

KEYBOARD

SCHMATIC ROBERTS 5000X

DATE- APP DWG. NO. 8-1001

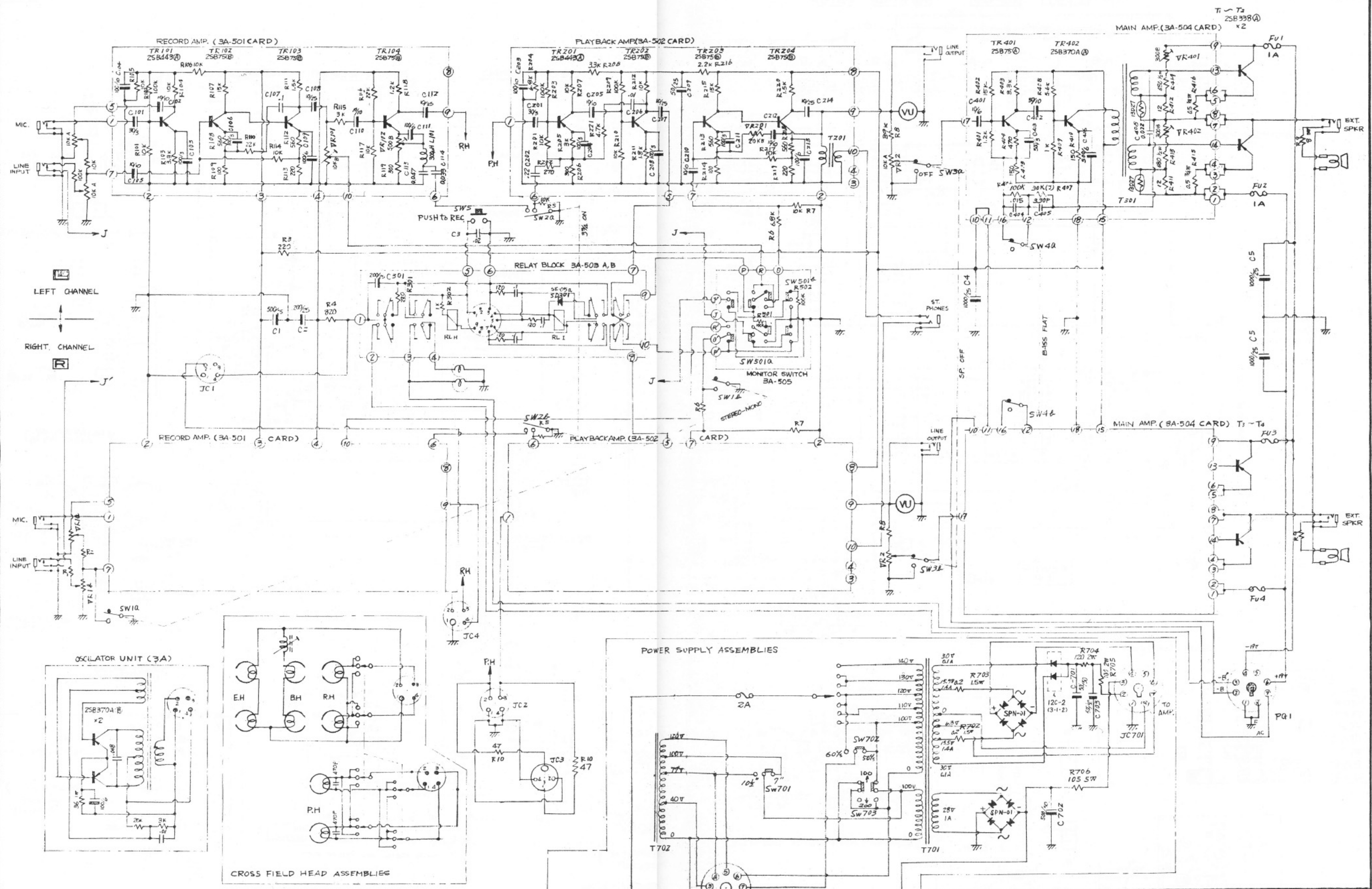

SCHEMATIC ROBERTS 400X ELECTRONICS  
 DATE- | APP | DWG. NO. 8-1003

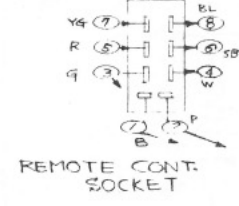
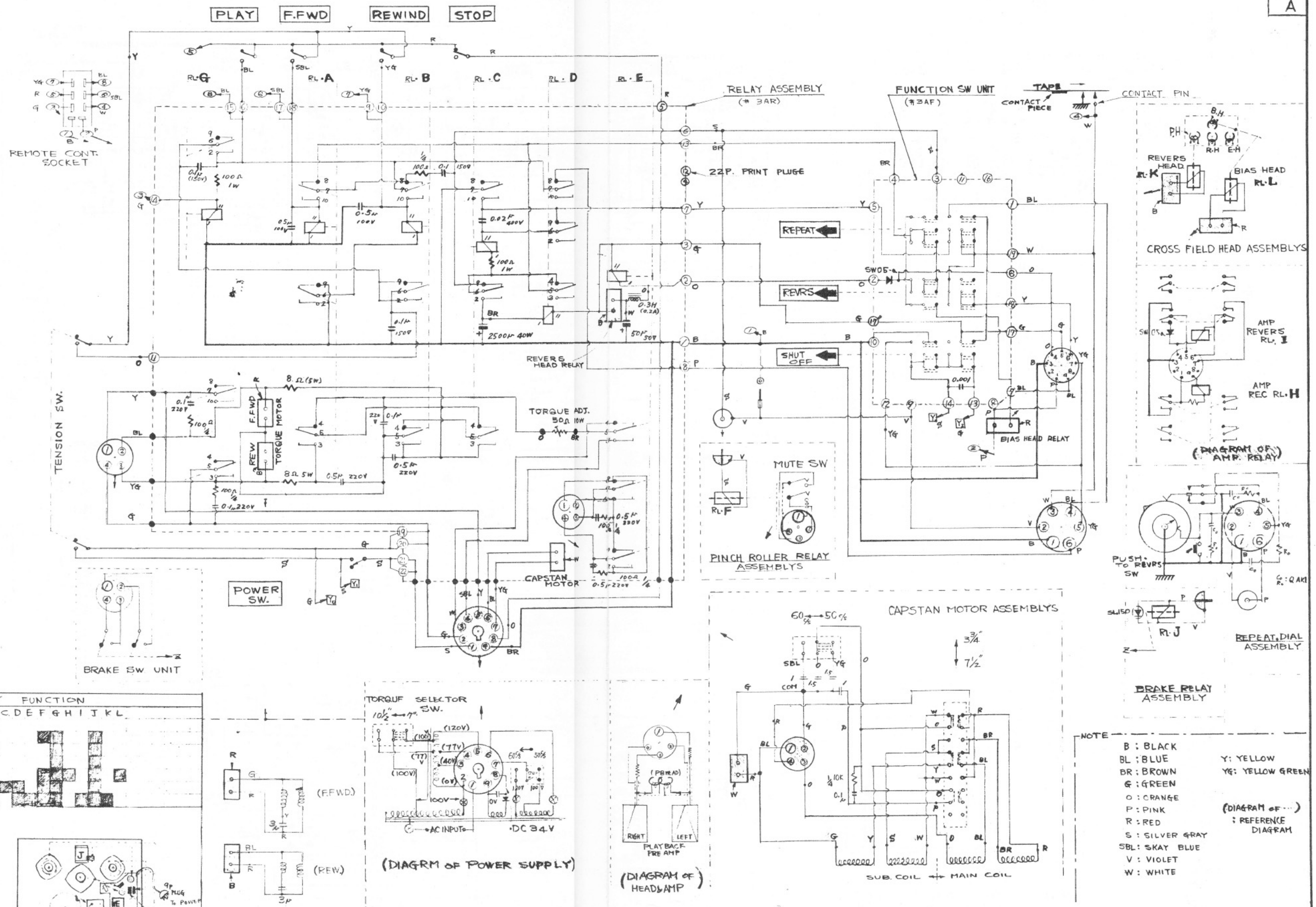

TENSION SW.

BRAKE SW UNIT

POWER SW.

REVERS HEAD RELAY

TORQUE ADJ. 50Ω 10W

CAPSTAN MOTOR

RELAY ASSEMBLY (+ 3AR)

FUNCTION SW UNIT (#3AF)

MUTE SW

PINCH ROLLER RELAY ASSEMBLY

CAPSTAN MOTOR ASSEMBLY

TAPE CONTACT PIECE CONTACT PIN

REVERS HEAD RL-K B.H. R.H. E.H.

BIAS HEAD RL-L

CROSS FIELD HEAD ASSEMBLY

AMP REVERS RL-I

AMP REC RL-H

(DIAGRAM OF AMP. RELAY)

PUSH TO REVERS SW

SLID SW RL-J

REPEAT DIAL ASSEMBLY

BRAKE RELAY ASSEMBLY

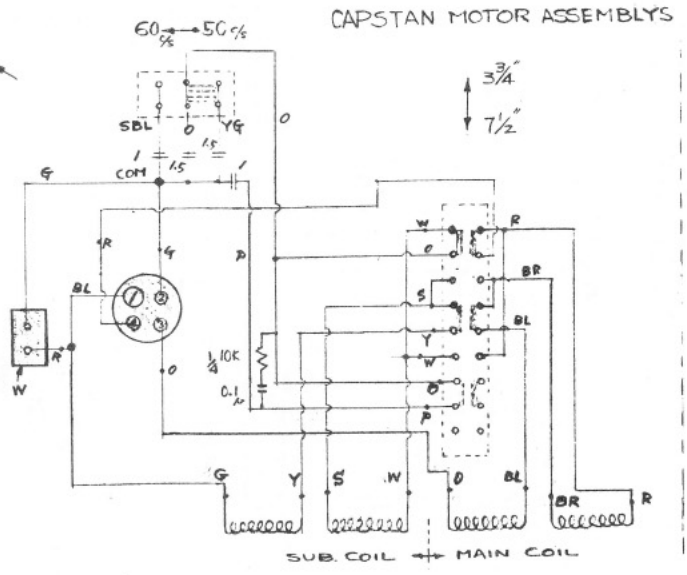
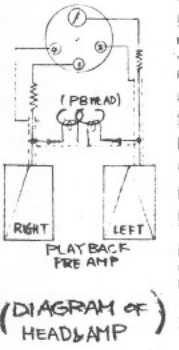
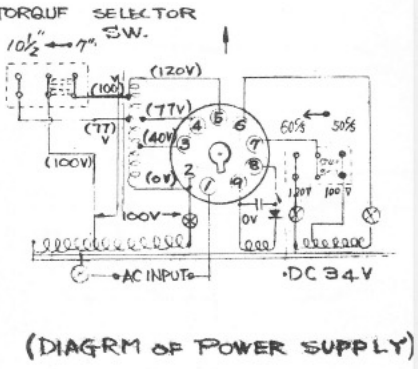
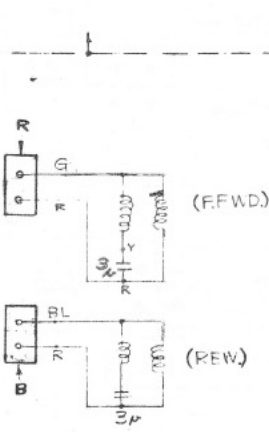
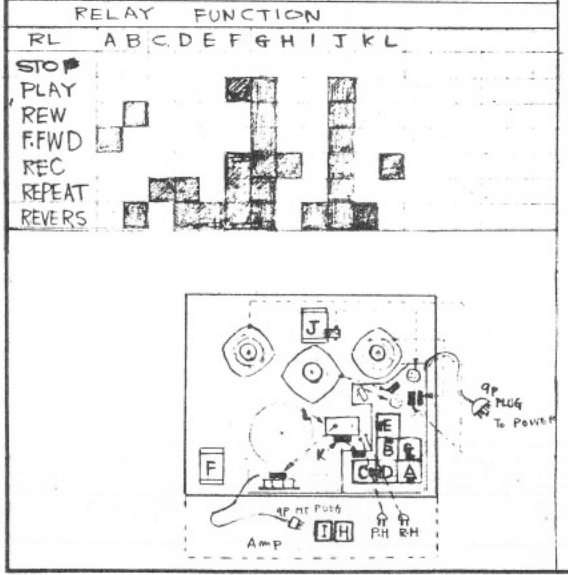

- NOTE
- B : BLACK
  - BL : BLUE
  - BR : BROWN
  - G : GREEN
  - O : ORANGE
  - P : PINK
  - R : RED
  - S : SILVER GRAY
  - SBL : SKAY BLUE
  - V : VIOLET
  - W : WHITE
  - Y : YELLOW
  - YG : YELLOW GREEN
- (DIAGRAM OF ...)  
: REFERENCE DIAGRAM

SCHEMATIC ROBERTS 400X TRANSPORT  
DATE - APP DWG. NO. 8-1002

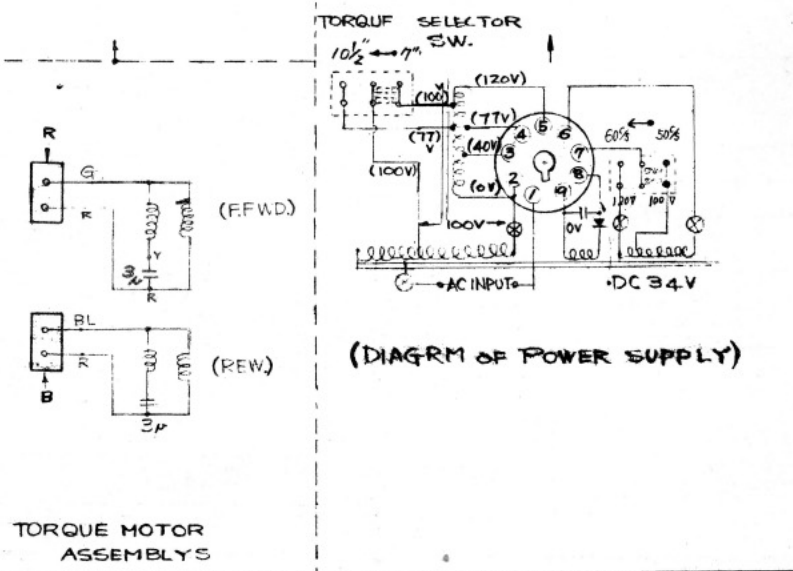
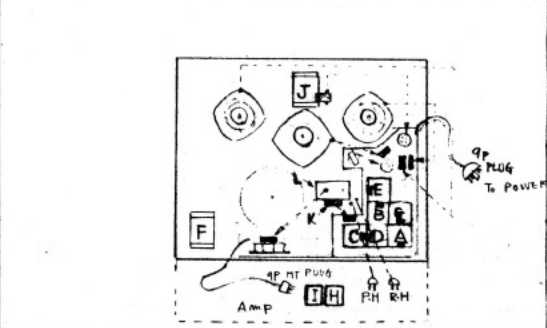
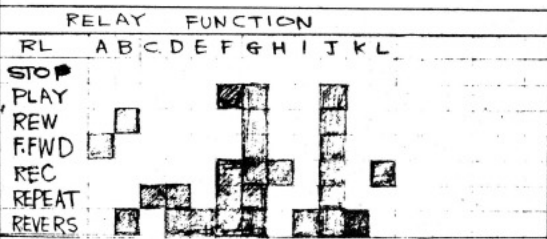
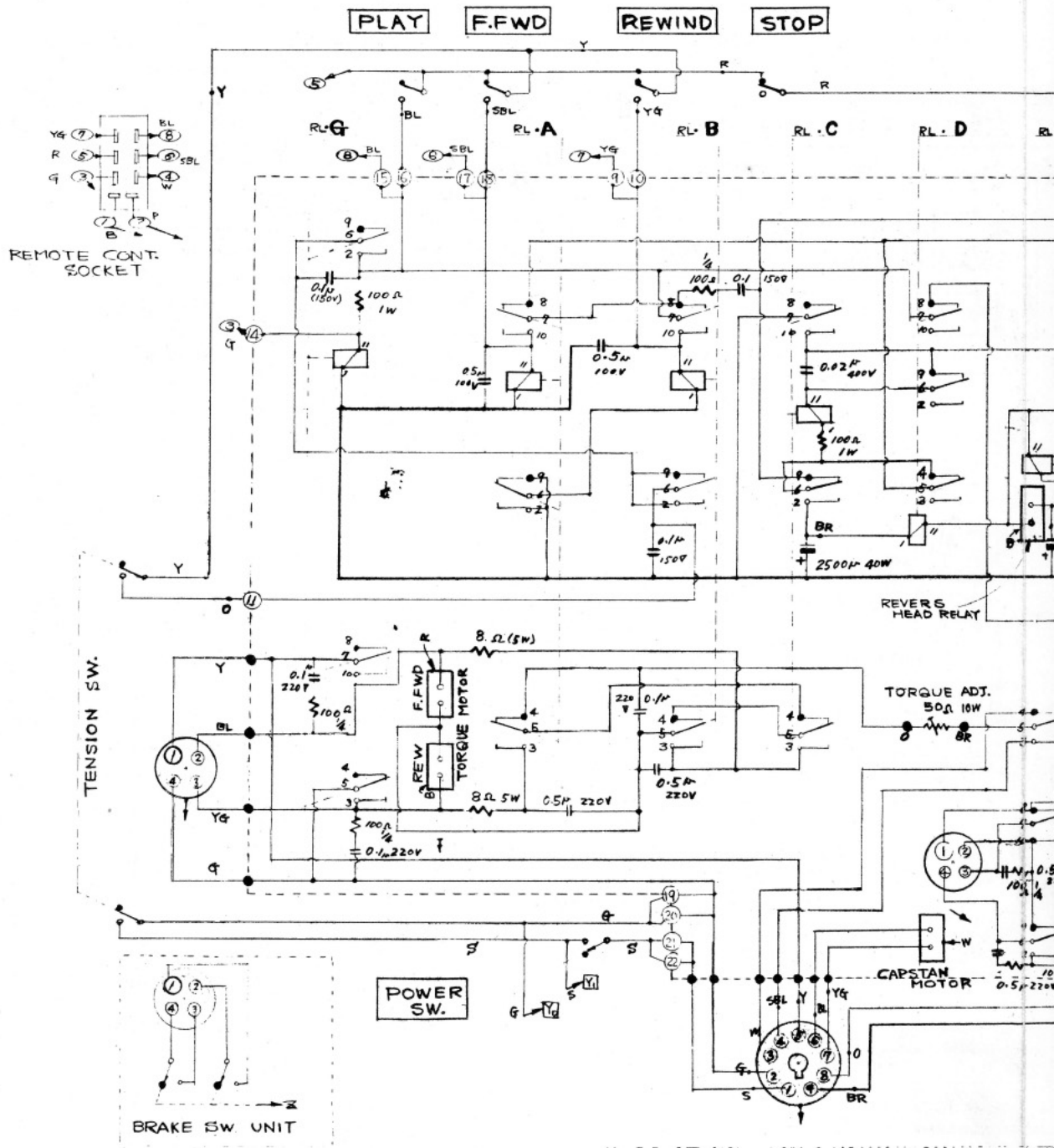

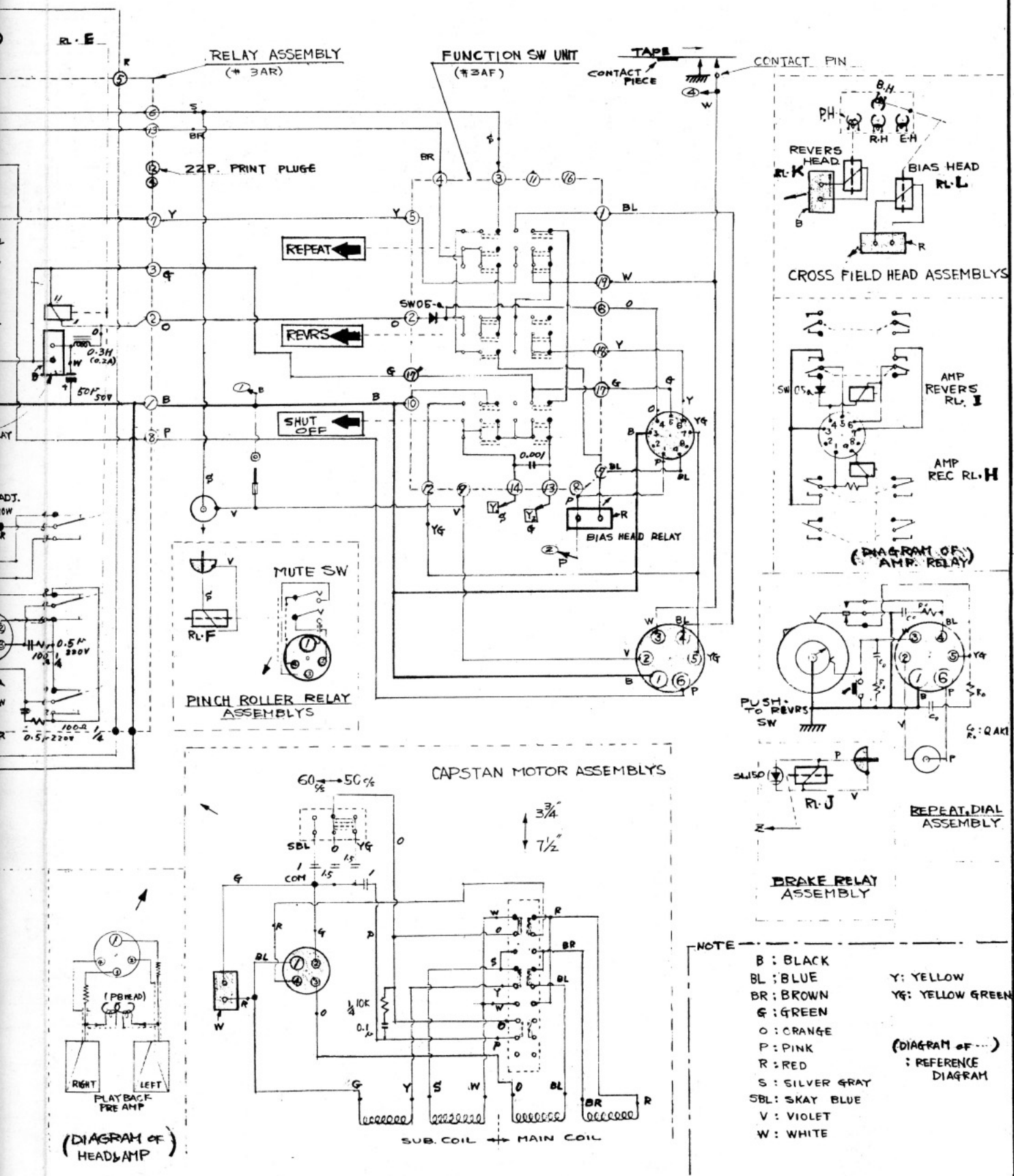

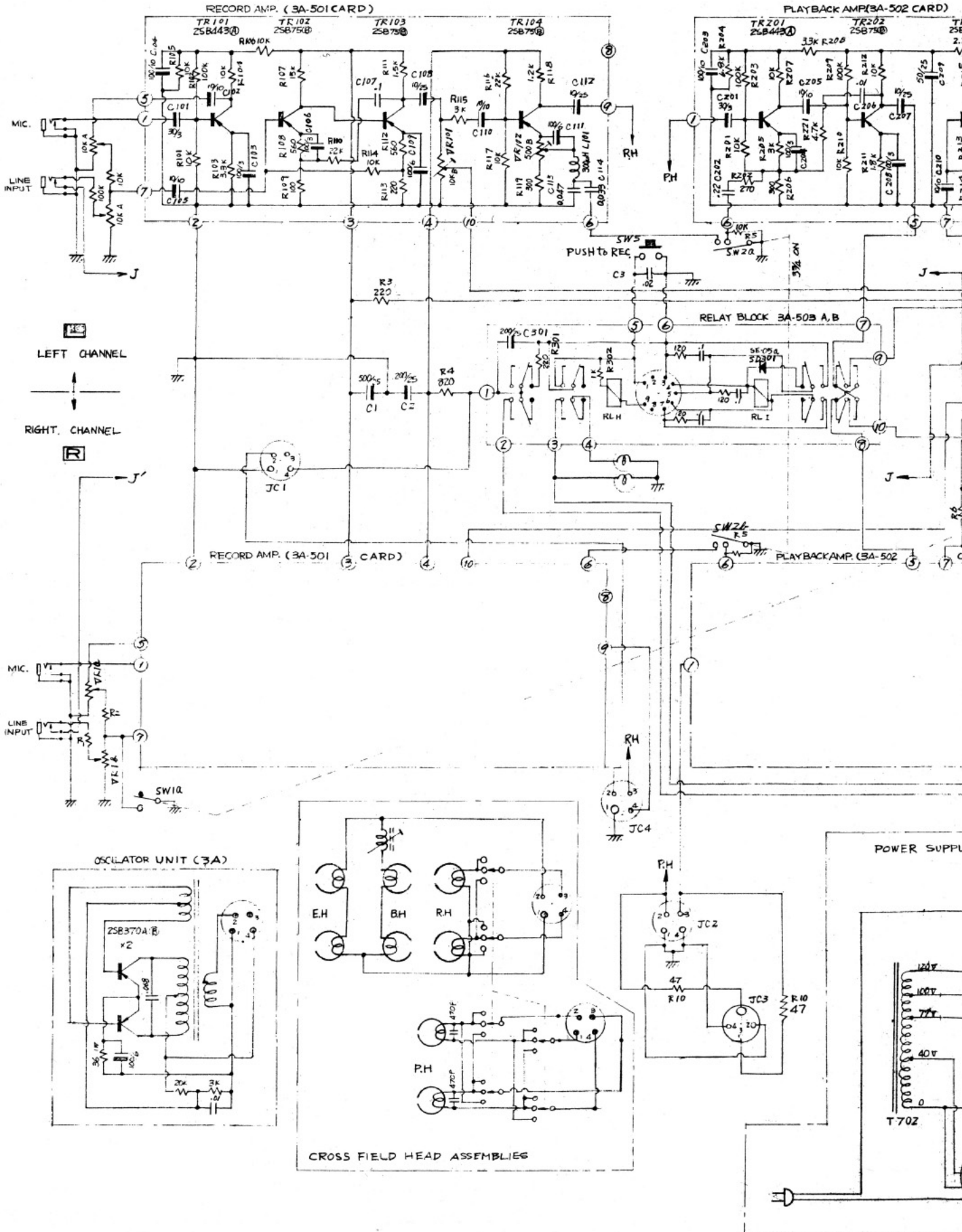



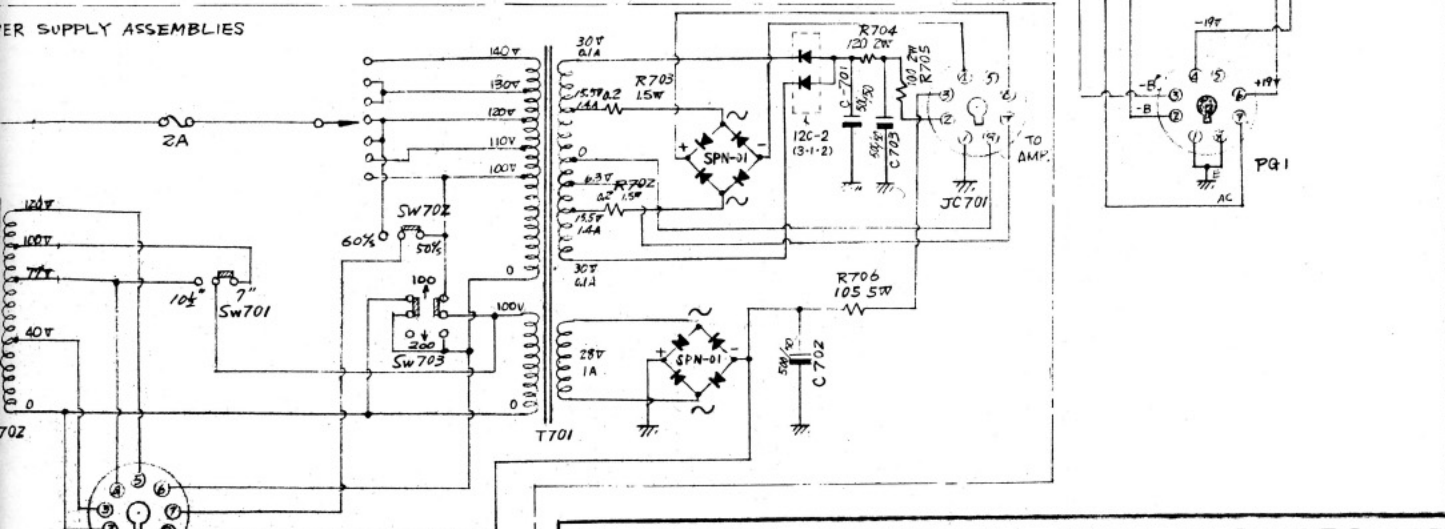
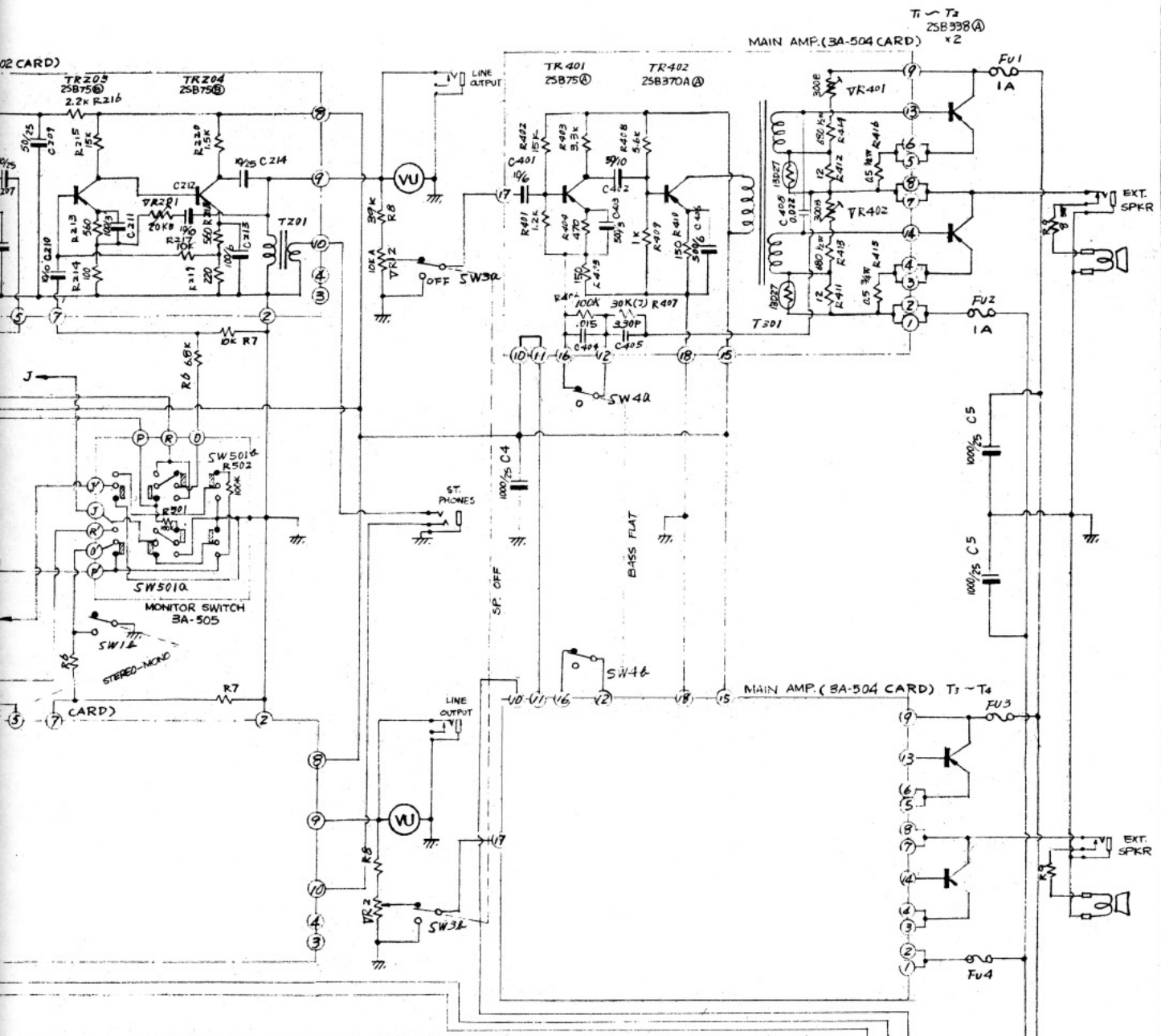

SCHMATIC ROBERTS 400X ELECTRONICS  
 DATE- APP DWG. NO. 8-1003