

MAGNEPLANAR MG-1.5/QR

INSTRUCTION MANUAL

(1)	INTRODUCTION	PAGE 1
(2)	GENERAL DESCRIPTION	PAGE 1
(3)	PACKAGING.	PAGE 1
(4)	ASSEMBLY	PAGE 1
(5)	HOOKUP	PAGE 2
(6)	CAUTION.	PAGE 5
(7)	SPEAKER PLACEMENT.	PAGE 5
(8)	ROOM ACOUSTICS	PAGE 8
(9)	OPTIONAL TWEETER ATTENUATION	PAGE 8
(10)	SUBWOOFERS	PAGE 9
(11)	MAINTENANCE.	PAGE 10
(12)	SPECIFICATIONS	PAGE 11

1. INTRODUCTION

Congratulations on your purchase. The Magneplanar MG-1.5/QR loudspeaker was conceived and designed for perfectionists. One of the most revealing loudspeakers made, it will provide outstanding music reproduction when used with high quality components. Due to the elegant simplicity and ruggedness of the design, the Magneplanar MG-1.5/QR loudspeaker will give many years of trouble-free service.

2. GENERAL DESCRIPTION

The MG-1.5/QR consists of a 2-way planar magnetic driver utilizing a common 1/2 mil. Mylar diaphragm. The voice grid of the bass section consists of lightweight aluminum wire. The Quasi Ribbon tweeter is made of 1 mil. aluminum foil.

3. PACKAGING

Save all packaging. If you need to transport the speakers, they can be shipped safely only in the original packaging. You may never have to return your loudspeakers, but should the occasion arise, they should not be shipped in any packaging but the original. Should you discard it, packaging is available.

4. ASSEMBLY

The four support feet for the MG-1.5/QR are shipped in the speaker carton along with the eight mounting bolts and 8 spacers. The nuts for the mounting bolts are already installed in the panel.

The spacers are provided to adjust the vertical angle of the speaker. The amount of angle will be dependent on your particular listening conditions. Under most conditions, stacking 2 spacers will be adequate; however, some experimentation may be necessary.

- A. Remove speakers, feet, bolts, and spacers from carton.
- B. We suggest the assistance of a second person will facilitate the installation of the feet. Hold a speaker upright on it's side.

- C. Locate the four holes in the fabric along lower backside of the panel.
- D. Carefully align foot on backside of panel so holes in the foot line up with the holes in the panel. Using your fingers, insert a bolt through the bottom hole and through the spacers (see Figure 1) until the bolt engages with the nut in the panel. Care must be taken not to crossthread the bolts.
- E. Repeat the same procedure for top hole, eliminating the spacers.
- F. Tighten all bolts securely.

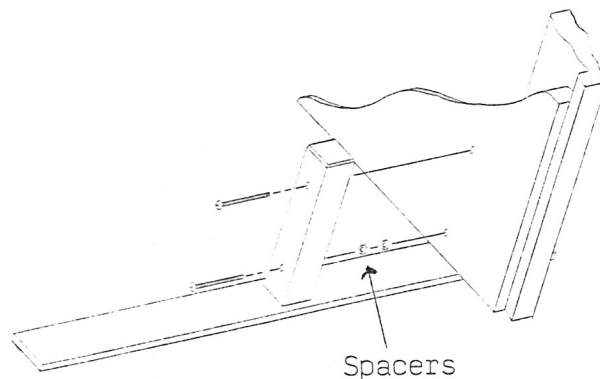

Figure 1

5. HOOKUP

The MG-1.5/QR features unique, high current connectors which provide optimum contact area with speaker cables up to 10 gauge.

The MG-1.5/QR is shipped ready for conventional or bi-wire hookup.

A. CONVENTIONAL HOOKUP

Simply strip 1/2" of insulation from the end of the cable. Insert the cable into the top set of connectors and tighten the set screws with the Allen wrench provided. Banana plug connectors can be used and locked in place with the set screws. To ensure proper phasing of the speakers, make sure the plus (red) is to plus and minus (black) is to minus.

B. BI-WIRE HOOKUP

These speakers are designed for utilizing bi-wire hookup techniques. The connection plate on the rear of each speaker is shown in Figure 2.

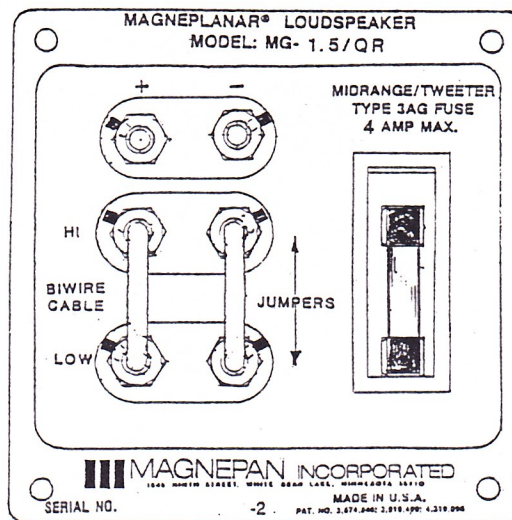

Figure 2

Bi-wiring requires two sets of speaker cables. They may be identical, or one set may be specialized for high frequencies and the other specialized for low frequencies. There are two ways to set up a bi-wire system.

1. METHOD #1: One stereo amp or two mono amps
 - a. Remove both jumpers.
 - b. Connect one set of cables to the low-cable input and the other set to the hi-cable input. Connect the other end of the cables together (observe +/- polarity), and connect to one channel of the amplifier outputs. If frequency specialized cables are used, connect them to their respective inputs. In either case the other ends are connected to the same amplifier channel.
 - c. Repeat same procedure for the other channel.

2. METHOD #2: Two stereo amps or four mono amps. This is a type of bi-amplification without an electronic crossover. Figure 3 shows the schematic of the speaker crossover.

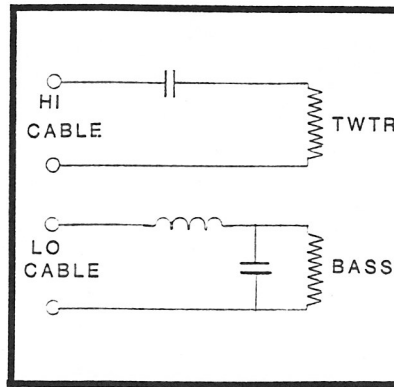

Figure 3

Although it is possible to use two dissimilar stereo amplifiers, it is preferable to use two identical stereo amplifiers, or four identical mono amplifiers.

- a. Plug a Y adaptor into both of the pre-amp outputs (left and right).
- b. Connect a pair of phono cables (four required) to each Y adaptor. Connect the other end of the phono cables to the two inputs on one of the stereo amplifiers (or two mono amplifiers).
- c. Connect one of the amplifier outputs to the speaker hi-cable input and the other to the low-cable input. Again, observe +/- polarity and proper utilization of frequency specialized cable, if used.
- d. Repeat same procedure for other channel.

If dissimilar amplifiers are used, you must utilize both channels of one amp on one speaker, and use the pre-amp balance control to balance the sound.

CAUTION: Some amplifiers with low input impedance may overload the pre-amp when utilizing this technique. Check with your pre-amp manufacturer.

6. CAUTION--CAUTION--CAUTION

- A. The speakers are shipped with 4 amp normal blow fuses in line with the tweeters. The bass section does not require fusing protection. This fuse value should never be increased or by-passed. Do not use slow-blow fuses. If these precautions are taken, our destruct tests show that it is impossible to burn out these drivers. BURNED OUT TWEETERS ARE NOT COVERED UNDER THE WARRANTY.
- B. For owners of cats, we recommend cat repellent around the base of the speakers.

7. SPEAKER PLACEMENT

Proper speaker placement and room acoustics can have more effect on a music system than upgrading one of the components in the system. Unfortunately, there is no definitive guideline which will cover all possible listening rooms. Some experimentation is required for locating the optimum position. The following are a few general guidelines:

- A. BASS RESPONSE--Play a record (or test signal) with repetitive bass. Try the speakers in several possible locations in the room. Begin experimenting with the speakers about 3 feet from a back wall. Try moving the speakers forward or backward in increments of 6 to 12 inches. One position in the room should be noticeably better than others. Also experiment with your chair location. Positions close to a wall will often result in increased bass (often too much). See Figure 4.
- B. STEREO WIDTH AND IMAGING--Once you have located the best position for the speakers and your chair for bass performance, separate the speakers by 50% of the distance from your chair to the speakers. (For example, if your chair is 10 feet from the speakers, move the speakers 5 feet apart.) Now, move the speakers apart in increments of 3 or 4 inches at a time, listening carefully at

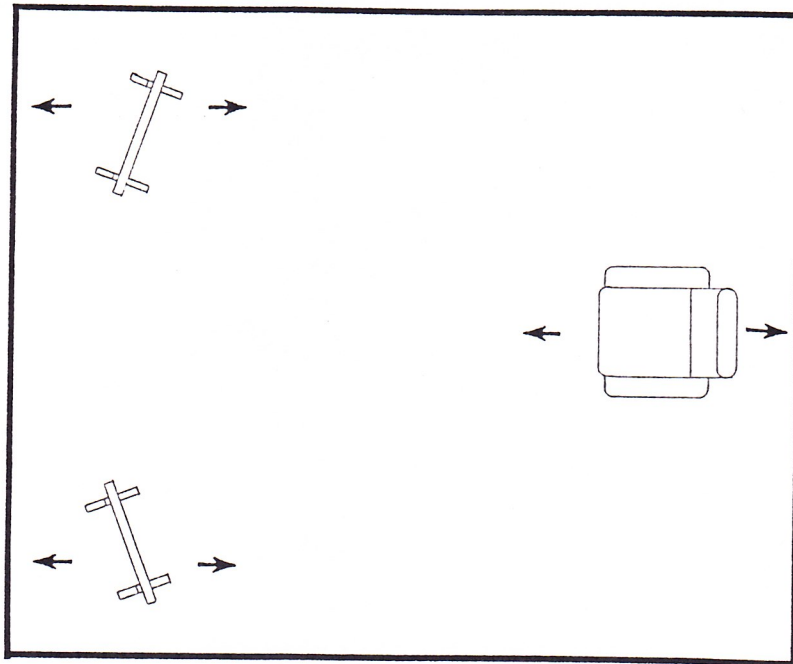

Figure 4

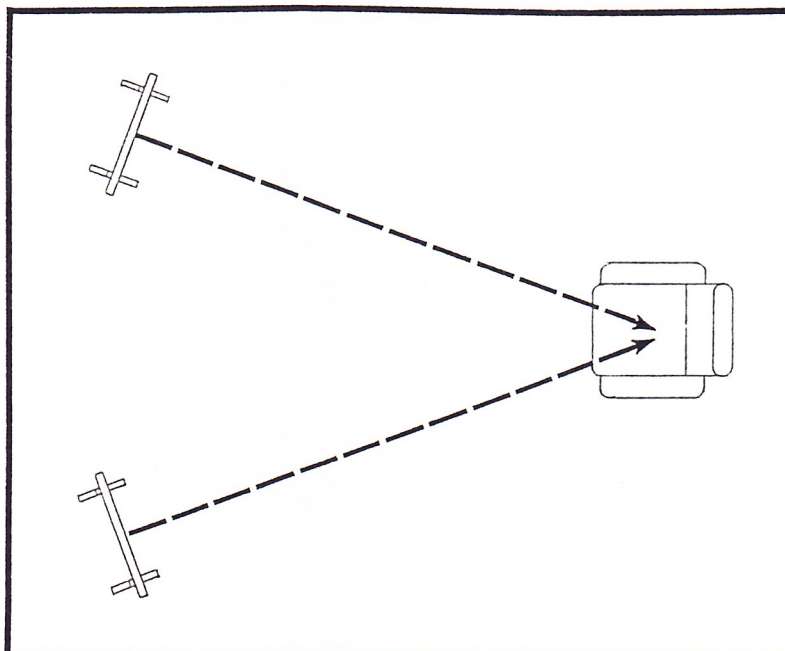

Figure 5

each position. At some point you will start to hear two separate speakers instead of a "stage effect" (or continuous image). When this occurs, your speakers are too far apart: begin moving the speakers back in small increments until you notice a point at which you achieve one cohesive "sound stage." For best results listen to speakers on axis with the listening position as shown in Figures 4 and 5.

C. LEFT/RIGHT

The MG-1.5/QR's are matched pairs and mirror-imaged. The serial number for each speaker in the pair is the same, except for a "1" or "2" following each serial number. As you face the front of the speakers, the speaker with the "1" after its serial number has the tweeter near the left edge, and the speaker with the "2" has the tweeter near the right edge.

Depending on room acoustics and your own personal listening tastes, you will probably prefer the sound with the tweeters on the inside; i.e. speaker "1" on the right and speaker "2" on the left. In most rooms this will increase the central focus of the sound and should improve imaging; however, some experimentation is recommended.

NOTE: Once you have located the ideal speaker position you should mark it. A small tack or piece of tape can be placed on the carpet so that your ideal listening spot can be easily relocated when the speakers (or chair) are moved for cleaning, etc. In the event that your ideal listening spot is inconvenient from the standpoint of the room layout and decor, simply slide the speakers wherever they look best. Experience has shown that the speakers can be placed close to a wall, and it will make little difference for FM or background listening.

The entire placement procedure may seem like a great deal of work, but is necessary in the set-up of any high quality system. The time and effort expended should only be necessary once, and will repay the owner with countless hours of musical enjoyment.

8. ROOM ACOUSTICS

Magneplanars, like other bipolar speakers, usually sound best with a moderately reflective surface behind the speakers. In situations where the speakers must be placed as close as 2 feet from the back wall, a heavy damping material directly behind the speakers is advised; however, it should not cover the entire wall.

Damping material in other parts of the room is a matter of trial and error. A word of caution--when audiophiles discover the effectiveness of damping material, they sometimes overdo it (on the premise that if a little is good, more is better). Before you make a permanent change to your room, experiment with the positioning of the damping material. Usually a portion of one of two parallel walls should have some damping.

An overdamped room will provide very precise imaging, but you will have a reduced sense of ambience (less reverberation, spaciousness, air, etc.). An underdamped room may heighten the illusion of being in a concert hall, but the imaging will seem imprecise with all the instruments mixed together. Be aware that so-called hardness or overbright sound is usually the result of a room with hard surfaces (glass, hard paneling, etc.). Moderation is the word.

9. OPTIONAL TWEETER ATTENUATION

There are two principal reasons for needing to attenuate the Magneplanar Ribbon Tweeter:

- A. Recordings, typically in the "pop" or "rock" vein, often exhibit a pronounced rise in the treble region.
- B. The Magneplanar Quasi Ribbon Tweeter is very efficient in its total "energy dispersion." If the surrounding walls are exceptionally reflective, the overall perceived acoustical balance will be tipped towards a "hot" high end.

Attenuation is performed through insertion of a simple non-inductive resistor in series with the tweeter (see Figure 6).

Replace the left-hand jumper with the appropriate resistor to obtain the desired tweeter attenuation. The pair of 1 ohm non-inductive resistors

will attenuate the tweeter 1-2dB. Other values are available from your Magneplanar dealer.

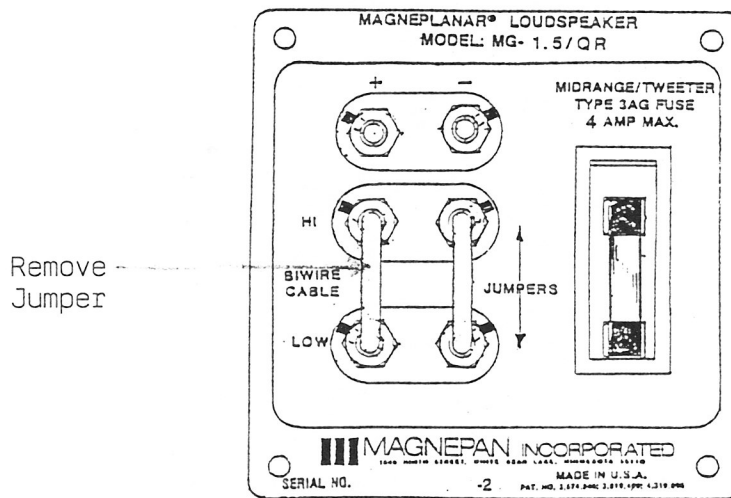

Figure 6

10. SUBWOOFERS

We don't recommend them. The first thing that should be obvious is that we would produce our own subwoofer if we felt that Magneplanars were deficient in bass. When Magneplanars are installed correctly, most people are very satisfied with the bass. We suspect that some people may have said Magneplanars need a subwoofer because they have never heard them set up properly.

The problem with adding a subwoofer is that you give up **QUALITY** of bass for **QUANTITY** of bass. **And for this questionable trade-off, you have to pay a lot of money!**

One of the most important features of Magneplanars is the amazing bass accuracy. To "muddy" the bass and midbass with a subwoofer seems like a poor investment. Electronic crossovers normally have 12 or 18dB per octave crossover slopes. Even if the subwoofer is brought in as low as 50Hz, there is still a substantial amount of sound coming from the subwoofer at 75 to 150Hz, and even higher. These higher bass frequencies coming from the subwoofer are not as accurate as the Magneplanar's bass, which results in "smearing" or "muddiness" of the sound. Once you become accustomed to

accurate bass, we believe you won't want to go back to the "boom" and "thump" of conventional woofers. Your Magneplanar dealer can help you obtain full bass potential from your Magneplanars.

11. MAINTENANCE

- A. The hardwood frames can be cleaned with a slightly damp dust cloth.
- B. Light vacuuming of the grille cloth is possible.

12. SPECIFICATIONS*

SYSTEM DESCRIPTION: Two-way full range planar magnetic dipole radiator.

BASS RADIATING AREA: 480 Sq. In.

QUASI RIBBON TWEETER SIZE: 1-1/2" X 52"

FREQUENCY RESPONSE: \pm 3dB 40Hz - 22KHz**

NORMAL POWER REQUIREMENTS: 100 Watts RMS 8 Ohms

MAXIMUM POWER REQUIREMENTS: 250 Watts RMS 8 Ohms

SENSITIVITY: 1 Watt 500Hz One meter 85dB

IMPEDANCE: 4 Ohms

CROSSOVER SYSTEM: Low pass--Quasi 12dB/Octave @300Hz
High pass--6dB/Octave @2500Hz

DIMENSIONS: 19" X 64" X 2"

WARRANTY: LIMITED. 3 Years to original owner

SHIPPING WEIGHT: 95 lbs.

*Because there are no universally accepted methods for loudspeaker measurements, frequency response specifications may be stated by most manufacturers without reference to measurement techniques and/or specific locations in rooms. Magneplanar loudspeaker frequency response specifications are minimum average performance levels that may reasonably be expected in normal installations.

**New Magneplanar MG-1.5/QR speakers will not display their full bass potential. After a month or two of use the bass response will lower a few cycles. At this point the response will stabilize and the speakers rated performance (or better) can be realized. While this 5Hz or more of lower bass response is important, the most important factors in obtaining good bass response from the MG-1.5/QR speakers are room size and geometry, wall material, and speaker placement.