

# JVC

## SERVICE MANUAL

### STEREO INTEGRATED AMPLIFIER

MODEL No. **AX-1100BK**

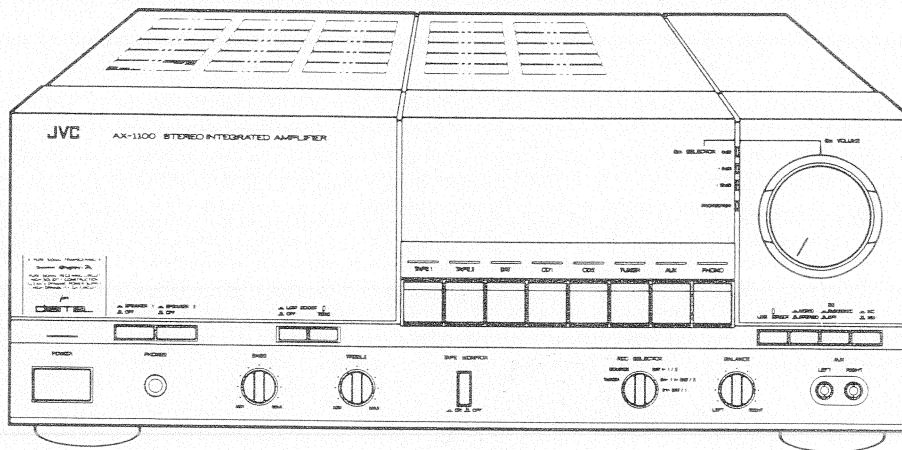

### Contents

Safety Precautions.....	Page 1-2		
Instruction Book.....	Page 1-3	Schematic Diagrams.....	Page Insertion
Description of Technology.....	Page 1-11	Internal Block Diagrams of ICs.....	Page Insertion
Removal Procedures.....	Page 1-13	Connection Diagram.....	Page Insertion
Adjustment Procedures.....	Page 1-14	Parts List.....	Separate Volume Insertion
		Block Diagram.....	Page 1-15

## Safety Precautions

1. The design of this product contains special hardware and many circuits and components specially for safety purposes.

For continued protection, no changes should be made to the original design unless authorized in writing by the manufacturer. Replacement parts must be identical to those used in the original circuits. Service should be performed by qualified personnel only.

2. Alterations of the design or circuitry of the product should not be made. Any design alterations or additions will void the manufacturer's warranty and will further relieve the manufacturer of responsibility for personal injury or property damage resulting therefrom.
3. Many electrical and mechanical parts in the product have special safety-related characteristics. These characteristics are often not evident from visual inspection nor can the protection afforded by them necessarily be obtained by using replacement components rated for higher voltage, wattage, etc. Replacement parts which have these special safety characteristics are identified in the Parts List of Service Manual. Electrical components having such features are identified by shading on the schematics and by ( $\Delta$ ) on the Parts List in the Service Manual. The use of a substitute replacement which does not have the same safety characteristics as the recommended replacement part shown in the Parts List of Service Manual may create shock, fire, or other hazards.
4. The leads in the products are routed and dressed with ties, clamps, tubings, barriers and the like to be separated from live parts, high temperature parts, moving parts and/or sharp edges or the prevention of electric shock and fire hazard.

When service is required, the original lead routing and dress should be observed, and it should be confirmed that they have been returned to normal, after re-assembling.

5. Leakage current check

(Electrical shock hazard testing)

After re-assembling the product, always perform an isolation check on the exposed metal parts of the product (antenna terminals, knobs, metal cabinet, screw heads, headphone jack, control shafts, etc.) to be sure the product is safe to operate without danger of electrical shock.

Do not use a line isolation transformer during this check.

- Plug the AC line cord directly into the AC outlet. Using a "Leakage Current Tester", measure the leakage current from each exposed metal part of the cabinet, particularly any exposed metal part having a return path to the chassis, to a known good earth ground. Any leakage current must not exceed 0.5 mA AC (r.m.s.).

- Alternate check method.

Plug the AC line cord directly into the AC outlet. Use an AC voltmeter having 1,000 ohms per volt or more sensitivity in the following manner. Use an AC line cord directly into the AC outlet. Connect a 1,500  $\Omega$  10 W resistor paralleled by a 0.15  $\mu$ F AC-type capacitor between an exposed metal part and a known good earth ground.

Measure the AC voltage across the resistor with the AC voltmeter.

Move the resistor connection to each exposed metal part, particularly any exposed metal part having a return path to the chassis, and measure the AC voltage across the resistor. Now, reverse the plug in the AC outlet and repeat each measurement. Any voltage measured must not exceed 0.75 V AC (r.m.s.). This corresponds to 0.5 mA AC (r.m.s.).

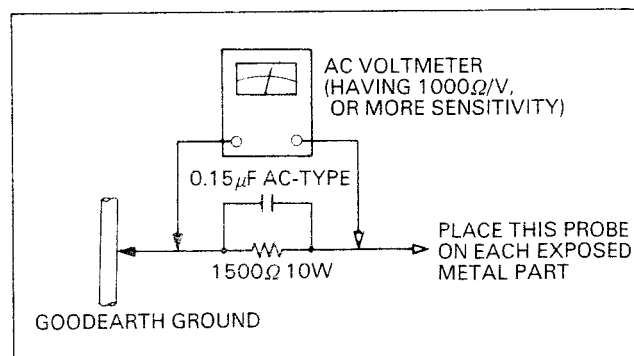

### CHECK THE VOLTAGE SELECTOR'S SETTING

(Except for U.S.A., Canada, Australia, U.K. and Continental Europe.)

Before inserting the power plug, please check that the voltage selector's setting corresponds with the line voltage in your area. If it doesn't, be sure to reset the voltage selector before this equipment.

The voltage selector may be located on the rear or bottom of the unit, or underneath the platter.

**CAUTION:** Before setting the voltage selector to the proper voltage, disconnect the power plug.

**IMPORTANT (In the United Kingdom)**  
**Mains Supply (AC 240 V~, 50 Hz only)**

**IMPORTANT**

Do not make any connection to the Larger Terminal coded E or Green. The wires in the mains lead are coloured in accordance with following code:



Blue to N (Neutral) or Black  
 Brown to L (Live) or Red

If these colours do not correspond with the terminal identifications of your plug, connect as follows:

Blue wire to terminal coded **N** (Neutral) or coloured Black.

Brown wire to terminal coded **L** (Live) or coloured Red.

*If in doubt – consult a competent electrician.*

**WARNING: TO REDUCE THE RISK OF FIRE OF ELECTRIC SHOCK, DO NOT EXPOSE THIS APPLIANCE TO RAIN OR MOISTURE.**

**CAUTION**

To reduce the risk of electrical shocks, fire, etc.:

1. Do not remove screws, covers or cabinet.
2. Do not expose this appliance to rain or moisture.

Thank you for purchasing this JVC product. Before you begin operating this unit, please read the instructions carefully to be sure you get the best possible performance. If you have any question, consult your JVC dealer.

**ACHTUNG**

Zur Verhinderung von elektrischen Schlägen, Brandgefahr usw.:

1. Keine Schrauben lösen oder Abdeckungen entfernen und nicht das Gehäuse öffnen.
2. Dieses Gerät weder Regen noch Feuchtigkeit aussetzen.

Vielen Dank für den Kauf dieses JVC-Produkts. Bitte lesen Sie diese Bedienungsanleitung sorgfältig, bevor Sie dieses Gerät in Betrieb nehmen, um die beste Leistung zu erhalten. Falls Sie Fragen haben, wenden Sie sich bitte an Ihren JVC-Fachhändler.

**ATTENTION**

Afin d'éviter tout risque d'électrocution, d'incendie etc.:

1. Ne pas enlever les vis ni les panneaux et ne pas ouvrir le coffret de l'appareil.
2. Ne pas exposer l'appareil à la pluie ni à l'humidité.

Tous nos compliments pour vous être procuré cet appareil de JVC.

Pour que vous puissiez obtenir les meilleures performances possibles, nous vous recommandons de lire attentivement la présente notice d'emploi avant de commencer à utiliser votre nouvel appareil.

En cas de question, consultez votre revendeur JVC.

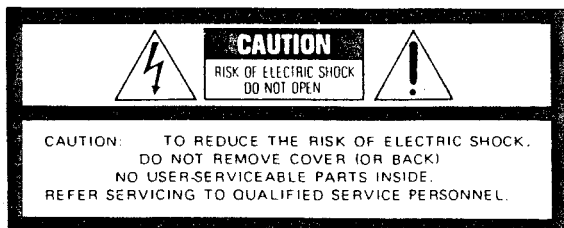

The lightning flash with arrowhead symbol, within an equilateral triangle, is intended to alert the user to the presence of uninsulated "dangerous voltage" within the product's enclosure that may be of sufficient magnitude to constitute a risk of electric shock to persons.



The exclamation point within an equilateral triangle is intended to alert the user to the presence of important operating and maintenance (servicing) instructions in the literature accompanying the appliance.

**IMPORTANT (CANADA ONLY/CANADA SEULEMENT)**

**CAUTION:** TO PREVENT ELECTRIC SHOCK DO NOT USE THIS (POLARIZED) PLUG WITH AN EXTENSION CORD, RECEPTACLE OR OTHER OUTLET UNLESS THE BLADES CAN BE FULLY INSERTED TO PREVENT BLADE EXPOSURE.

**ATTENTION:** POUR PREVENIR LES CHOCS ELECTRIQUES NE PAS UTILISER CETTE FICHE POLARISEE AVEC UNE PROLONGATEUR. UNE PRISE DE COURANT OU UNE AUTRE SORTIE DE COURANT, SAUF SI LES LAMES PEUVENT ETRE INSEREES A FOND SANS EN LAISSER AUCUNE PARTIE A DECOUVERT.

**VOORZICHTIG**

Ter voorkoming van gevaar voor brand, elektrische schokken, enz.:

1. Verwijder geen schroeven, panelen of de behuizing.
2. Stel dit toestel niet bloot aan regen of vocht.

Dank U voor het in dit JVC produkt gestelde vertrouwen.

Lees deze gebruiksaanwijzing vóór ingebruikname van dit toestel aandachtig door ter verkrijging van de beste prestaties.

Raadpleeg Uw JVC handelaar in geval van twijfel.

**PRECAUCION**

Para reducir riesgos de electrochoques, incendio, etc.:

1. No extraiga los tornillos, cubiertas o la caja.
2. No exponga este aparato a la lluvia o humedad.

Deseamos, antes que nada, agradecerle por la compra de unos de los productos de JVC.

Antes de poner esta unidad en operación, asegúrese de leer estas instrucciones para, de tal modo, obtener el mayor rendimiento posible.

Cualquier duda o pregunta, sírvase dirigirse a su concesionario JVC.

**VARNING**

Elektriska stötar och överslag i apparaten kan elimineras genom följande:

1. Ta inte bort skruvar, lock eller ytterhölje från apparaten.
2. Utsätt inte apparaten för regn eller fukt.

Tack för att du skaffade dig denna JVC-produkt.

Läs igenom bruksanvisningen noga för att lära känna till komponenten och dess egenskaper, så att du tillfullt kan njuta av dess prestanda.

Rådfråga JVCs representant, när du vill ställa frågor som inte besvaras i bruksanvisningen.

# CONNECTION DIAGRAM

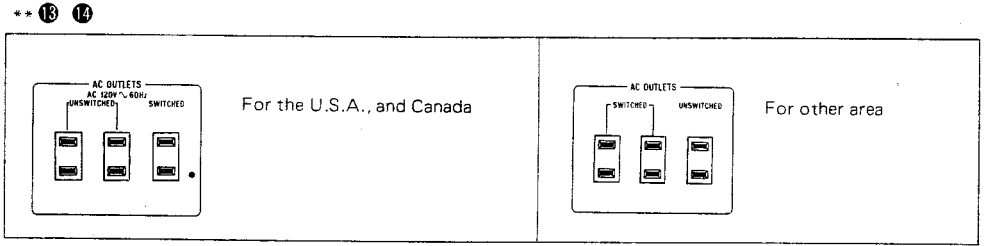
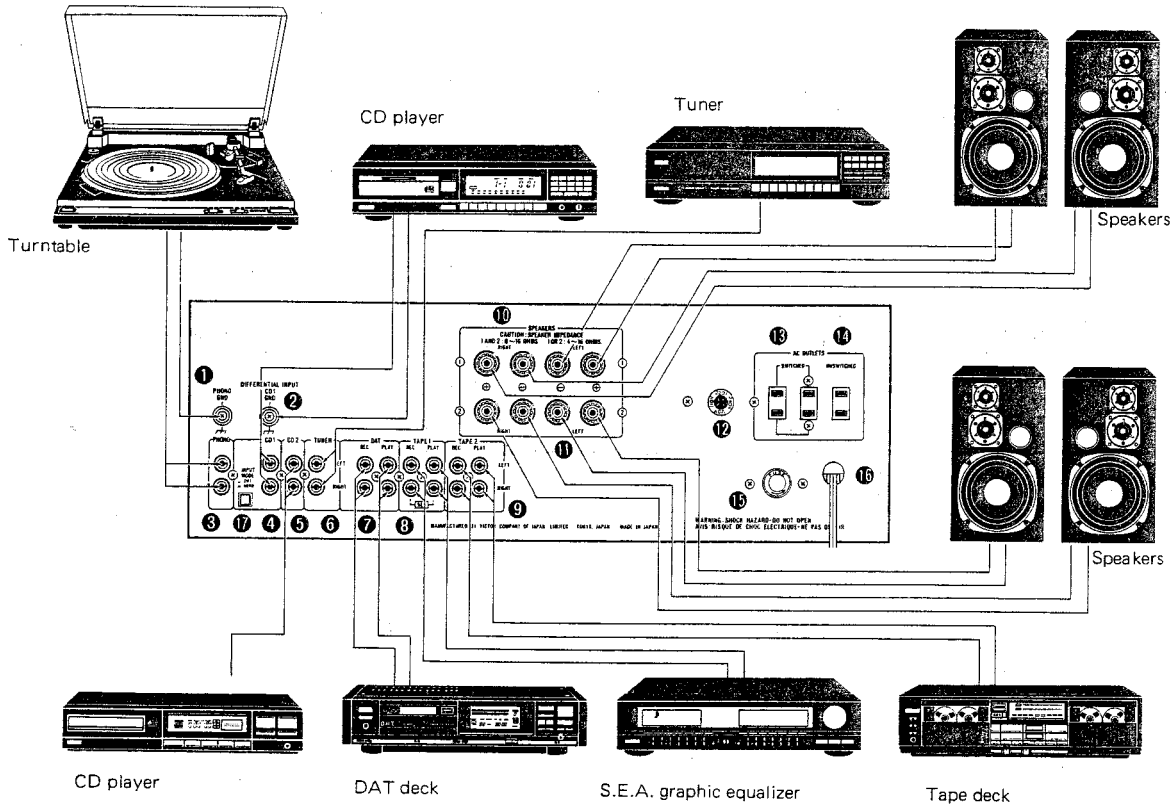

Fig. 2

- 1 PHONO GND terminal  
If your turntable has separate ground lead, connect it to the GND terminal.
  - 2 DIFFERENTIAL INPUT CD1 GND  
If your CD player has separate ground lead, connect it to the GND terminal. Refer to page 23.
  - 3 PHONO terminals
  - 4 CD1 terminals
  - 5 CD2 terminals
  - 6 TUNER terminals
  - 7 DAT terminals  
A DAT deck is connected. However, ordinary cassette decks and open reel decks may also be connected.
  - 8 TAPE-1/SEA terminals  
These terminals can also be used for connecting an S.E.A. graphic equalizer. See page 25.
  - 9 TAPE-2 terminals
  - 10 SPEAKERS system 1 terminals
  - 11 SPEAKERS system 2 terminals
  - 12 AC LINE VOLTAGE SELECTOR\*
  - 13 SWITCHED AC outlets\*\*
  - 14 UNSWITCHED AC outlet\*\*
  - 15 AC fuse socket\*
  - 16 Power cord
  - 17 INPUT MODE  
This switch is used for selecting the type of input for the CD1 terminal and setting is influenced by the connections for GND terminal (2). (Refer to page 23 of the instruction manual.)
- \* Not provided on units for the U.S.A. Canada, continental Europe, the United Kingdom and Australia.
- \*\* Not provided on units for continental Europe, the United Kingdom and Australia.

- Notes:**
- 1. Connect source components with left and right channels connected correctly. Reversed channels may degrade the stereo effect.
  - 2. Connect speakers with correct polarity; (+) to (+) and (-) to (-). Reversed polarity may degrade the stereo effect.
  - 3. Switch the power off when connecting any component.
  - 4. Connect plugs or wires firmly. Poor contact may result in hum.
  - 5. Use the speakers with impedance of 6 ohms or more (12 ohms if the ! + 2 position is used) as the rated speaker impedance of this amplifier is 6 ohms (12 ohms when the 1 + 2 position is used).  
(For Continental Europe, Australia and the U.K.)  
Use the speakers with impedance of 4 ohms or more (8 ohms if the ! + 2 position is used) as the rated speaker impedance of this amplifier is 4 ohms (8 ohms when the 1 + 2 position is used).  
(For the U.S.A., Canada and other areas)
  - 6. Connecting speakers is easy.
  - 7. Do not connect equipment requiring more than the rated power to the AC outlets on the rear panel.
  - 8. The SWITCHED AC outlets are switched off when the front panel power switch is switched off.
  - 9. The UNSWITCHED AC outlet is not switched off when the front panel power switch is switched off.

## DESCRIPTION AND FUNCTIONS

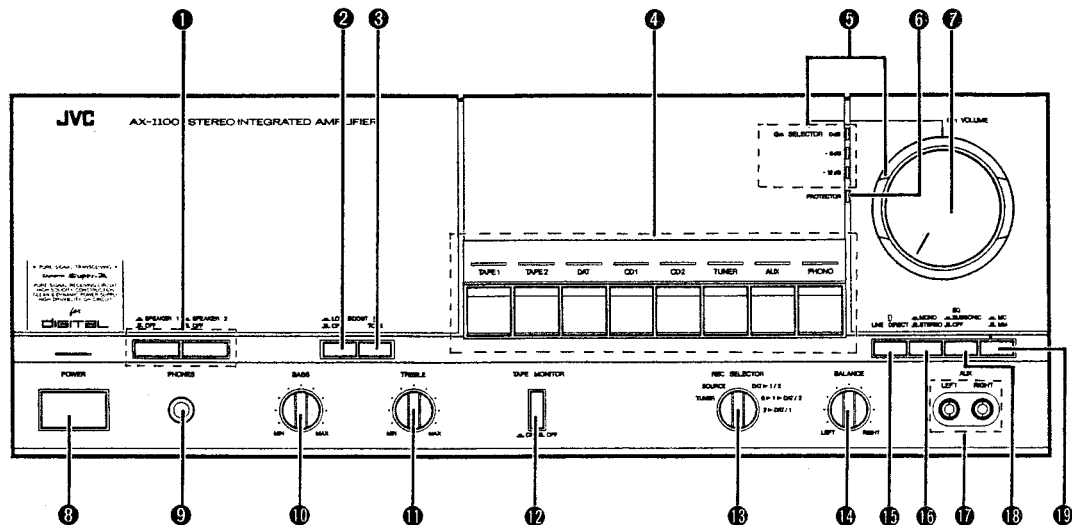

Fig. 3

**1 SPEAKERS**

Press to switch the speakers connected to the SPEAKERS 1 or 2 terminals on ( ) and off ( ).

**Notes:**

- When speakers are connected to only one pair of SPEAKERS terminals, press only the SPEAKERS button of the system connected; if both buttons are pressed, sound will not be heard from either speaker system. When two pairs of speakers are connected and either of both SPEAKERS buttons is/are pressed, sound will be heard from either or both speaker system(s).
- When the load impedance of this button is lower than 4 ohm, the protection circuit operates and the protection indicator begins flashing. In this case, the speakers and the headphones may not generate sound.

**2 LOW BOOST**

**LOW BOOST** ( ): Press this button to reinforce the low frequency range. Dynamic sound can be enjoyed at low listening volume.

**OFF** ( ): Set to this position to cancel the low boost effect.

**3 TONE button**

Press this button to adjust the tone with the BASS and TREBLE controls. The TONE indicator lights.

Press again to obtain a standard (flat) frequency response with the BASS and TREBLE controls switched off.

**4 TAPE/SOURCE SELECTOR**

**TAPE SELECTOR:** TAPE 1, TAPE 2, DAT (digital audio tape recorder)

**SOURCE SELECTOR:** CD1, CD2, TUNER, AUX, PHONO

Select the desired sound source using this selector.

When using the tape selector, make sure to press TAPE MONITOR button (12) beforehand.

When the TAPE/SOURCE button for the desired sound source is pressed, the indicator above the button lights.

**Note:**

- If the TAPE MONITOR button is not pressed before setting the TAPE/SOURCE selector, the indicator of the selected sound source will not light and also the sound source will not change.

**5 Gm SELECTOR**

Setting the Gm SELECTOR to  $-6$  dB divides the volume at 0 dB by 4 while setting it to  $-12$  dB divides it by 16. As the Gm SELECTOR is turned from 0 dB to  $-6$  dB and  $-12$  dB, residual noise becomes progressively less. Use the Gm SELECTOR together with the Gm VOLUME control.

**0 dB:** Set the Gm SELECTOR so that this indicator lights when listening to a high-volume source.

**$-6$  dB:** Set the Gm SELECTOR so that this indicator lights when listening to a middle-volume source.

**$-12$  dB:** Set the Gm SELECTOR so that this indicator lights when listening to a low-volume source.

**6 Protection indicator**

This indicator flickers for several seconds after the power has been switched on and lights when functioning is stable. While this indicator is flickering, sound cannot be heard from the speakers.

When the protection circuit works during use, the indicator flickers to show a malfunction. In this case, turn the power off and consult your JVC dealer.

**7 Gm VOLUME control**

Adjust the volume of the speakers or headphones.

The scale is graduated in dB steps of attenuation with reference to the maximum position.

This VOLUME control is different from an ordinary volume control because the system varies the gain of the amplifier. Therefore, even if the volume is lowered, it is possible to listen to the music with a high S/N ratio and low distortion because the residual noise is not increased.

**8 POWER switch**

Press this switch to turn the power on. The indicator above it lights. Press again to turn the power off.

**9 PHONES jack**

Insert the plug of the headphones into this jack.

**Note:**

- To listen through headphones only, set the SPEAKERS selector to OFF.

**10 BASS control**

Turn clockwise to boost bass response and counterclockwise to decrease it.

**11 TREBLE control**

Turn clockwise to boost treble response and counterclockwise to decrease it.

**12 TAPE MONITOR button**

Press this button to listen to tapes. The indicator above it lights. Select the desired tape deck with the TAPE SELECTOR.

**Notes:**

- When the indicator above this button is lit, listening to records or broadcasts is impossible. In this case, press this button so that the indicator goes off.
- Press this button to monitor the recorded sound (to listen to the sound recorded) using a three-head tape deck.

**13 REC SELECTOR**

**TUNER:** Set to this position to record broadcasts while listening another source.

**SOURCE:** Set to this position to record from sources connected to the PHONO, TUNER, CD1, CD2 or AUX terminals.

**OFF:** Set to this position when you are not recording or dubbing.

**DAT-1/2:** Set to this position to dub from DAT deck to the TAPE 1 deck or TAPE 2 deck.

**S-1-DAT/2:** Set to this position to dub from the TAPE 1 deck to the DAT deck or to TAPE 2 and to record the source selected with the SOURCE SELECTOR onto the TAPE 1 deck.

**2-DAT/1:** Set to this position dub from TAPE 2 deck to DAT deck or TAPE 1 deck.

**14 BALANCE control**

Use to adjust the balance between the left and right speakers. Normally set this control to the center click position.

**15 LINE DIRECT**

When this button is pressed the indicator above the button lights. By means of this, the mode switch (MONO, STEREO) and the balance volume circuit are passed for all input regardless of the knob setting. This enables reproduction of better sound quality.

**16 MONO/STEREO**

**MONO** (  ): Set to this position to have both speakers produce the sound of both the left- and right-channel signals mixed.

**STEREO** (  ): Normally set to this position.

**17 AUX**

Convenient for connecting an extra Audio equipment.

**18 EQ SUBSONIC**

**SUBSONIC** (  ): Press in if ultra-low noise is noticeable.

**OFF** (  ): Normally set to this position.

**Note:**

• **This button operates only when the SOURCE SELECTOR is set at PHONO.**

When a sound source other than PHONO is set, characteristics will not change on turning this button ON and OFF.

**19 MC/MM switch**

**MC** (  ): Press in when using an MC cartridge having an output of less than 0.5 mV.

**MM** (  ): Press again when using an MM or MC cartridge having an output of more than 0.5 mV.

## OPERATION

### Note:

- Sound does not come from the speakers for several seconds after the power has been applied until the protection indicator lights after flickering, therefore, if the Gm VOLUME control is turned too much to the right during this period, a sudden surge of sound may damage the speakers. Do not turn the Gm VOLUME control when the protection indicator is flickering.

### Listening to broadcasts/records

1. Connect a tuner/turntable to the TUNER/PHONO terminals on the rear panel.
2. Press the POWER switch.
3. Press the TUNER/PHONO button and make sure that the TAPE MONITOR indicator does not light.
4. Select the speaker system with the SPEAKERS selector.
5. Operate the tuner/turntable according to its instruction manual.
6. Set the MC/MM switch as required when listening to records.
7. Adjust the Gm VOLUME, LOUDNESS, BALANCE and TONE BASS/TREBLE controls.

### Listening to tapes

#### To listen to the tape deck connected to the TAPE-1, TAPE-2, DAT terminals.

1. Connect a tape deck to the TAPE-1, TAPE-2, DAT PLAY terminals.
2. Press the POWER switch in.
3. Press the TAPE MONITOR button in so that the TAPE MONITOR indicator lights.
4. Select the speaker system with the SPEAKERS selector.
5. Set the TAPE SELECTOR to "1", "2" or "DAT".
6. Operate the tape deck for playback according to its instruction manual.
7. Adjust the controls for optimum sound.

#### Listening to CD1 or CD2

1. Connect a CD player to the CD1 or CD2 terminals on the rear panel.
2. Press the POWER button on.
3. Press the CD button and make sure that the TAPE 1 MONITOR and TAPE 2 MONITOR buttons are set to off.
4. Select the speaker system with the SPEAKERS switches.
5. Operate the CD player according to its instruction manual.
6. Adjust the VOLUME, LOUDNESS, BALANCE and BASS/TREBLE controls.

### Recording tapes

#### 1. Recording from records

1. Connect a tape deck to the TAPE-1, TAPE-2, DAT REC terminals.
2. Press the POWER switch in.
3. Select the speaker system if you wish to hear the sound while recording.
4. Set the PHONO button. Check that the TAPE MONITOR indicator does not light.
5. Set the MC/MM switch as required.
6. Set the REC SELECTOR to SOURCE.
7. Operate the turntable.
8. Operate the tape deck for recording.

#### 2. Recording from other sources (TUNER, AUX, CD)

Press the TUNER, AUX or CD button according to the source you want to record. All other operations are identical to when recording from records.

When recording broadcasts, setting the REC SELECTOR allows you to record it regardless of the position of the source selector. Therefore it is possible to listen to the other source while recording a broadcast.

### Notes:

- You can also monitor the sound being recorded with headphones.
- The sound you hear from the speakers or headphones is the source sound, not that having just been recorded on the tape.
- If you have a three-head tape deck with independent record and play heads, you can monitor the recorded sound while recording. For this purpose:
  - (1) Press the TAPE MONITOR button in (  ).
  - (2) When you are recording with the three-head tape deck connected to the TAPE-1 (TAPE-2, DAT) terminals, set the TAPE SELECTOR to "1" (2, DAT).
- The Gm VOLUME control of this amplifier has no effect on the recording level. Adjust the recording level with the controls of the tape deck.

### 3. Tape dubbing

For dubbing you must have two tape decks, one for playback and one for recording. With the AX-1100BK, you can dub from the deck connected to the TAPE-1 terminals to the deck connected to the TAPE-2 or DAT terminals or vice versa.

1. Connect tape decks to the TAPE-1 and TAPE-2 or DAT terminals (see connection diagram).
2. Press the POWER switch in.
3. Press the TAPE MONITOR button in.

#### 1. To dub from TAPE-1 to TAPE-2 or/and DAT

4. Set the REC SELECTOR to "S - 1 - DAT/2"
5. To monitor the source sound, set the TAPE SELECTOR to "1".  
To monitor the sound after being recorded when a three-head tape deck is used for TAPE-2 or DAT, set the TAPE SELECTOR to "2" or "DAT".
6. Operate the TAPE-1 deck for playback.
7. Operate the TAPE-2 or/and DAT deck(s) for recording.

#### 2. To dub from TAPE-2 to DAT or/and TAPE-1

4. Set the REC SELECTOR to "2 - DAT/1" position.
5. To monitor the source sound, set the TAPE SELECTOR to "2".  
To monitor the sound after being recorded with a three-head tape deck connected to the TAPE-1 or/and DAT terminals, set the TAPE SELECTOR to "1" or "DAT".
6. Operate the TAPE-2 deck for playback.
7. Operate the TAPE-1 or/and DAT deck for recording.

#### 3. To dub from DAT to TAPE-1 or TAPE-2

4. Set the REC SELECTOR to "DAT - 1/2".
5. To monitor the source sound, set the TAPE SELECTOR to "DAT".  
To monitor the sound after being recorded with a three-head tape deck connected to the TAPE-1 terminals, set the TAPE SELECTOR to "1" or "2".
6. Operate the DAT deck for playback.
7. Operate the TAPE-1 or TAPE-2 deck for recording.

#### 4. Listening to a record, broadcast, etc. while dubbing



1. Set the TAPE MONITOR button to the "out" position.
2. Press the source button (PHONO, TUNER, etc.) of the source to be listened to.
3. Apart from this, the dubbing procedure is the same as that described above.

### Using stereo headphones

Stereo headphones can be plugged into the front panel jack. The signal from this jack is independent of the speakers.

1. Plug stereo headphones into the PHONES jack.
2. For private listening, set the SPEAKERS selector to OFF.
3. To listen through headphones, while at the same time listening to speaker sound, select the required speaker system as well.

### Note on DIFFERENTIAL INPUT:

Differential input is possible with through the CD1 input terminal of this unit by setting switch (  ) INPUT MODE on the rear panel to the depressed DIFF (  ) DIFFERENTIAL INPUT setting. When connections are made with units having a GND terminal (JVC's XL-V1100 CD player and similar models), set this switch at the depressed setting.

(  ): In this instance, connect the attached earth wire between the differential GND terminal of this unit and the GND terminal of the unit connected to the CD1 terminal.

NORM (  ): When the switch is set at the NORM setting, input is the same as that for other input terminals. (In this instance, do not connect the attached earth wire.)

### IMPORTANT:

- Always connect this wire during differential input; otherwise, abnormal noise interference may occur.
- Disconnect the wire during normal input as noise interference may also occur if it is left connected for normal input.

### Note:

- Differential input is used to send only the signal current between this unit and the CD1 terminal by separating it from the accompanying noise interference current, such as digital noise and power source noise. This enables sending of a truer signal to enable a much higher level of sound reproduction.



## CONNECTING AN S.E.A. GRAPHIC EQUALIZER

S.E.A. graphic equalizers are exclusive JVC tone control systems. By allowing you to boost or lower the response of different sections of the frequency spectrum independently, an S.E.A. unit gives you much greater control over the tone of your stereo system. With an optionally available S.E.A. graphic equalizer, you can tailor the sound for different types of music or to compensate for the acoustic response of your audio components and listening room. The TAPE-1 terminals of the AX-1100BK can be used for connecting an S.E.A. graphic equalizer.

### Connection

1. Connect the TAPE-1 REC terminals to the SEA INPUT terminals.
2. Connect the TAPE-1 PLAY terminals to the SEA OUTPUT terminals.
3. Connect a tape deck to the TAPE terminals of the S.E.A. graphic equalizer as shown.
4. Press the TAPE MONITOR button so that the indicator lights.
5. Set the TAPE SELECTOR to "1".
6. Set the REC SELECTOR to TUNER, SOURCE or "DAT - 1/2" or "S - 1 - DAT/2" or "2 - DAT/1".

For more details of its connection and operation, refer to the instruction book of the S.E.A. graphic equalizer.

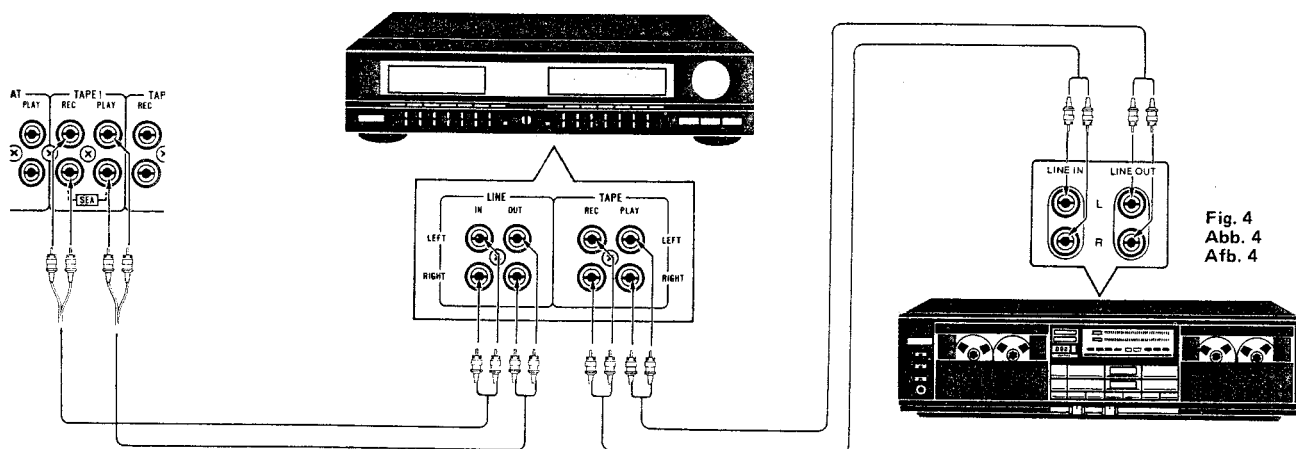

Fig. 4  
Abb. 4  
Afb. 4

## TROUBLESHOOTING

What appears to be a malfunction may not always be serious.

Make sure first . . . . .

### No sound and no lights

- Is the AC plug properly connected?
- Are the connections made correctly?

### No sound from speakers

- Are speaker cords connected?
- Is the SPEAKERS selector set correctly?
- Is the Gm VOLUME control set properly?
- Is the TAPE MONITOR indicator lit?
- Are your source components correctly installed?

### Sound from only one speaker

- Are the speaker cords connected correctly?
- Is the BALANCE control set to one extreme or the other?

### Loud hum during record playing

- Is turntable grounded?
- Try to change cord path.

### Howling noise during record playing

- Is turntable too close to speaker?

## SPECIFICATION

## CIRCUITRY

Preamplifier : ICL, MC/MM equalizer with EL-FETs in its initial stage  
 Power amplifier : "Dynamic Super-A" power amplifier with Gm circuit

## ALLOVER CHARACTERISTICS

Output power (CD IN  $\rightarrow$  SP. OUT)  
 : **120 watts per channel, min. RMS, both channels driven into 8 ohms from 20 Hz to 20 kHz, with no more than 0.003% total harmonic distortion**  
 140 watts 6 ohms, 20 Hz – 20 kHz, 0.005 %  
 125 watts per channel, min. RMS, both channels driven, into 8 ohms at 1 kHz with no more than 0.0005% total harmonic distortion  
 130 watts per channel, min. RMS, both channels driven, into 8 ohms at 1 kHz with no more than 0.7% total harmonic distortion  
 160 watts 1 kHz, 6 ohm 0.7%

## Total harmonic distortion

CD1  $\rightarrow$  SP. OUT : 0.003% (20 Hz – 20 kHz, 8 ohms) at 120 watts  
 PHONO IN  $\rightarrow$  SP: 0.007% (20 Hz 20 kHz, OUT at volume 8 ohms) at 120 watts –30 dB

## Intermodulation distortion

(CD1 IN  $\rightarrow$  SP. OUT) : 0.001% (60 Hz: 7 kHz = 4 : 1, 8 ohms) at 120 watts

## Power band width

(CD1 IN  $\rightarrow$  SP. OUT) : 7 Hz – 60 kHz (IHF, 0.05% , 8 ohms both channels driven)

Frequency response: 3 Hz – 100 kHz + 0, (CD1, 2, TUNER, –3 dB (8 ohms) AUX1, TAPE-1, -2, DAT)

Damping factor : 150 (1 kHz, 8 ohms)

## Input terminals

Input sensitivity/impedance (1 kHz)  
 PHONO (MM) : 2.5 mV/47 kohms  
 PHONO (MC) : 200  $\mu$ V/470 ohms  
 CD1 : 200 mV/220 kohms  
 TUNER, CD2 : 200 mV/43 kohms  
 AUX 1 : 200 mV/43 kohms  
 TAPE-1, 2, DAT : 200 mV/43 kohms

## Signal to noise ratio

PHONO (MM) : 86 dB/80 dB  
 PHONO (MC) : 70 dB (250  $\mu$ V input)  
 CD1 : 106 dB/85 dB  
 TUNER, CD2 : 110 dB/85 dB  
 AUX : 110 dB/85 dB  
 TAPE-1, 2, DAT : 110 dB/85 dB ('66 IHF/DIN)

## POWER SPECIFICATIONS

Areas	Line voltage & frequency	Power consumption
U.S.A.	AC 120 V $\sim$ , 60 Hz	470 watts, 600 VA
Canada		
Continental Europe	AC 220 V $\sim$ , 50 Hz	360 watts
Australia	AC 240 V $\sim$ , 50 Hz	720 watts
U.K.		
Other Areas	AC 110/120/220/240 V $\sim$ selectable, 50/60 Hz	360 watts

# Description of Technology

Accompanied by the popularization of CD players and video equipment, the environment of amplifiers has changed due to the following:

1. Serious noise caused by the digitalization of audio sources and by the proliferation of microcomputer and AV equipment
2. Greatly widened dynamic range of audio sources
3. Increase in speakers having lower impedance
4. Interference with signal amplification caused by sound pressure and vibrations

In this environment, in an age when digital audio sources are mainly used, countermeasures to the peripheral equipment interfacing problems is one of the most important methods to improve the performance of present amplifiers in actual use situations. To overcome these problems in the AX-1100BK, we've developed a new technology, called "Pure Signal Transceiving", consisting of the following four basic technologies.

## ■ Pure Signal Receiving Circuit

In conventional connections, there is a "loop" which includes the power supply line between an amplifier and audio source components. This causes noise current to flow in other than the audio signals, and thus results in a degradation of the signal-to-noise ratio. Within this noise current, it is known that the internal clock of digital equipment, servo noise, etc., as well as power line noise, is output as common mode noise.

In Fig. 1, power line noise and digital noise flows around loop 1 (in). Due to the ground impedance,  $Z_w$ , of the signal connection line consisting of the loop, voltage noise,  $e_n (= in \cdot Z_w)$ , is induced into the signal voltage,  $e_s$ , as a series addition.

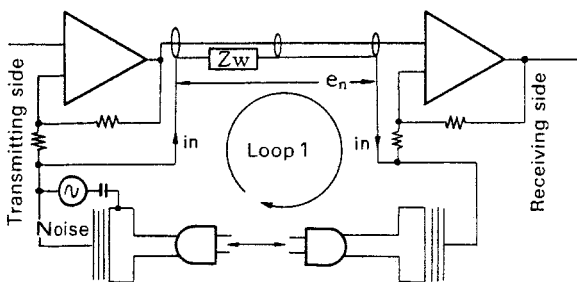

Fig. 1 Conventional connection diagram

In the "pure signal receiving circuit", as shown in Fig. 2, the noise current (in) which flows on the chassis is coupled to a second ground line. Thus no current, other than the signal current, is applied to the shield wire ground line, which is the reference point for the signals. The audio signals transmitted from the source equipment are received by differential amplifier A1, resulting in a precise signal transmission.

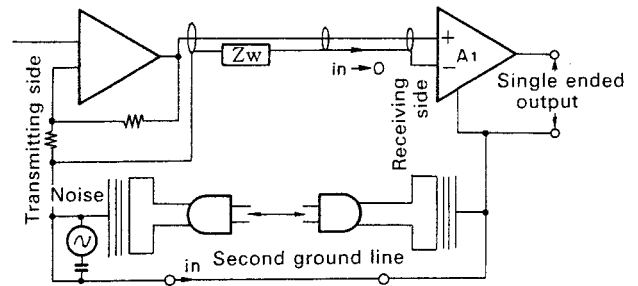

Fig. 2 Connections in the Pure Signal Receiving Circuit

Since a higher CMRR (common-mode rejection ratio) and low-noise performance (for 1-gain operation) are required for differential amplifier A1, a differential amplification circuit with superior characteristics has been developed exclusively for this purpose, by a combination of discrete parts and general purpose op amps.

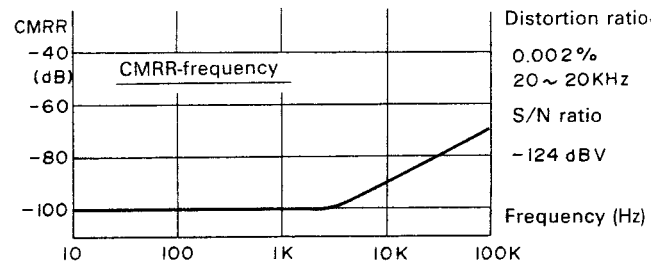

Fig. 3 CMRR characteristics of the differential amplifier

## ■ High-drivability Gm Circuit

In conventional power amplifier design, an 8-ohm impedance is normally used as the design center. However, this was changed to a 6-ohm impedance, to reinforce the driving performance for lower load impedances. Since the amount of current is greatly increased and the operation is performed at a lower voltage, the following countermeasures are performed.

1. Use of parallel output transistors
  - (1) The maximum output current is greatly increased when compared to a conventional single type
  - (2) Expansion of the effective ASO
  - (3) Performance is improved because the load per output transistor is half that of conventional types
2. In the large current loop, a smaller amount of PC Board patterns are used, and wires are mostly used for connections to lower the impedance.
3. The impedance after the NFB point is lowered by the use of remote sensing. As a result, the low-impedance loading and damping factor characteristics are greatly improved.

## ■ Clean & Dynamic Power Supply

In actuality, rectifying noise greatly depends on the inductance of the power transformer windings and the rectifier diode recovery time. It may radiate electromagnetically from the line connecting the transformer to the rectifier diode. To reduce the rectifying noise and power

supply noise from this, the following countermeasures are adopted.

1. The rectifier circuit is connected directly to the power transformer, to minimize the noise radiating lines.
2. The entire power supply section is shielded, and is located in a position separated from the amplification stage. This greatly reduces the effect on the amplifying operation.
3. The secondary winding of the power transformer is a balanced winding, to reduce the unbalanced components between the primary and the secondary windings. With this, a favorable result is obtained for inputting/outputting of a power line noise to the amplifier.

### ■ High-Solidity Construction

In the newly developed chassis construction, the power transformer, rectifying electrolytic capacitors, and output stage heat sink, which are normally origins of vibration, are located on an anti-shock copper plate with a thickness of 1.6 mm. This prevents vibrations from being transmitted to the amplifier circuits. In addition, the solidity of the chassis is greatly improved to reduce external sound pressure and vibrations.

### ■ Total Performance

The total performance of the AX-1100BK, designed with "pure signal transceiving" technologies, is as follows:

1. Fig. 5 shows the amplifier outputs measured when a 1 kHz signal is reproduced by a CD player. As shown in Fig. 4, noise is present in the spectrum of a conventional amplifier, other than the required signal.

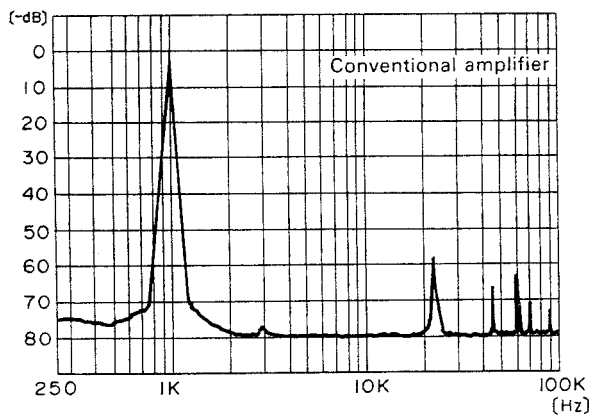

Fig. 4

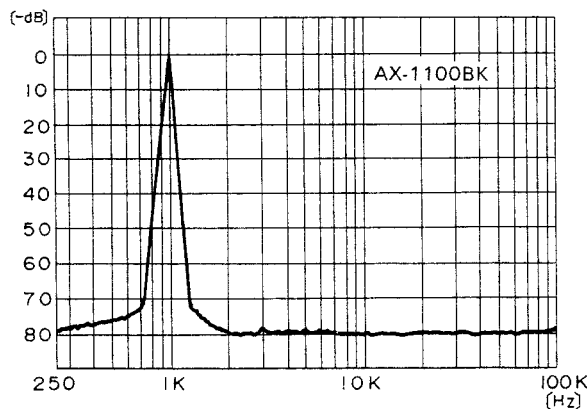

Fig. 5

2. For load resistance versus maximum output characteristics, the AX-1100BK has linear output characteristics which are nearly the same as the ideal curve, even when operated with an impedance of 4 ohms or less.

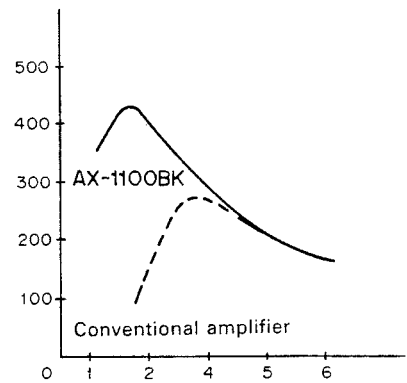

Fig. 6

3. Power supply noise which occurs in the amplifying stage is greatly reduced when compared to that of a conventional amplifier (shown in Fig. 7).

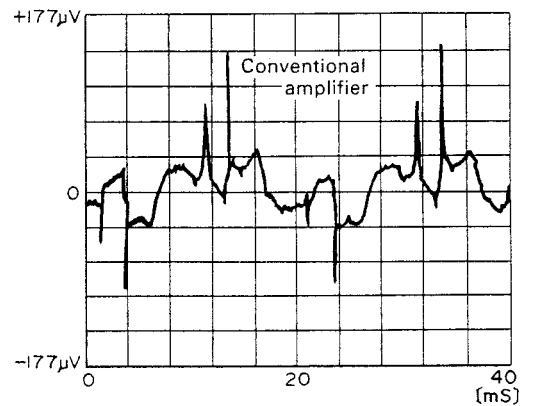

Fig. 7

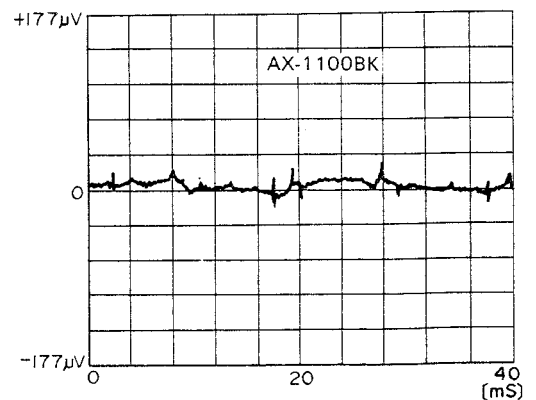

Fig. 8

## Removal Procedures

### ■ Removing the Metal Cover

1. Remove the four screws on both sides.
2. Remove the three screws located on the top of the rear panel.
3. Slightly push both sides of the metal cover, to the left and right, and raise the rear panel. Then slowly lift it up and straight forward.

### ■ Removing the Power Transistors

1. Remove the metal cover.
2. Remove all 29 screws holding the bottom plate. Then remove the bottom plate.
3. Unsolder the power transistors.
4. Remove the screws holding the power transistors using the bent screwdriver, or a wrench having a diagonal length of 5.5 mm.

**Note:** The part number of the bent screwdriver is "EBSJ-1005".

### ■ Removing the Front Panel

1. Remove the metal cover.
2. Pull off the Gm volume knob, and remove the securing nut from the volume shaft.
3. Remove the six screws holding the front panel (three screws each for the upper and lower sections), and then pull out the front panel.

### ■ Precautions When Installing the Arm

When replacing the Gm selector switch (S301), the arm is also removed. When reinstalling the arm, follow these precautions:

1. Turn the switch shaft counterclockwise all the way.
2. Place the arm horizontally, with the line mark on the right side, then insert the arm.

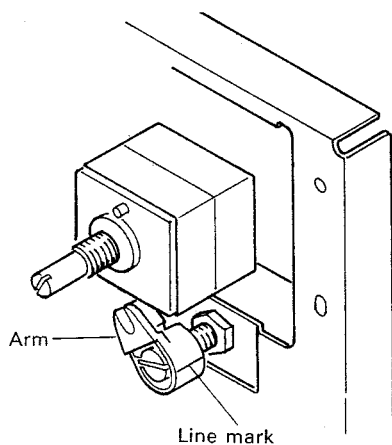

### ■ Precautions When Installing the Front Panel

1. Place the Gm selector knob, turned fully clockwise, on the front panel.
2. Turn the arm fully counterclockwise.
3. After placing the Gm selector knob and the arm correctly, install the front panel.
4. When installing the panel, be careful not to forget the spacers (for the AUX jacks).

### ■ Precautions When Installing the Gm Volume Knob

When removing the front panel, the Gm volume knob is also removed. When reinstalling it, follow these precautions:

1. Turn the Gm selector knob fully clockwise.
2. Turn the volume knob fully counterclockwise.
3. Place the Gm volume knob on the shaft. Match the point mark on the Gm selector knob with the indication on the Gm volume knob.

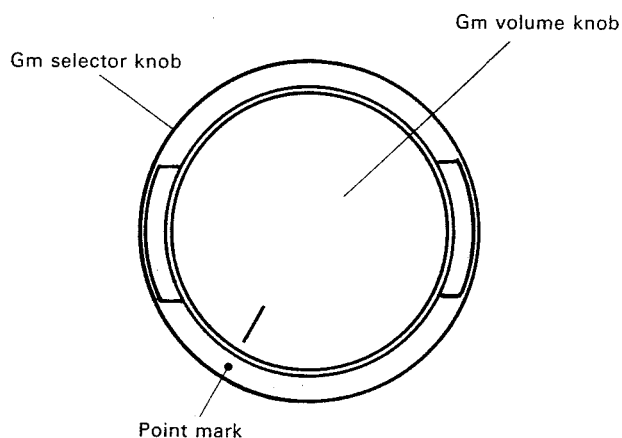

### ■ Handling the Remote Switches

Raise the lugs indicated in the figure and use tweezers to remove them.

**Note:** Be especially careful of the flexible cables during disassembling and assembling operations. Do not bend or sharply twist them. When placing the flexible cables during reassembly, be sure to install them the same routings (flexible cable path) as those before disassembly.

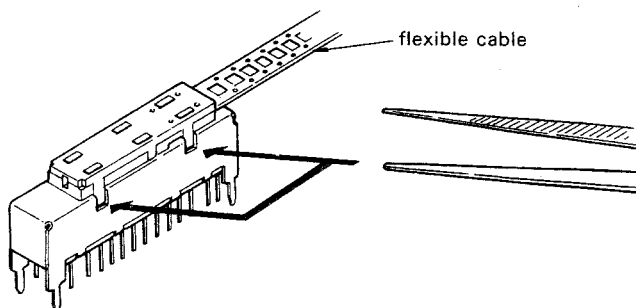

# Adjustment Procedures

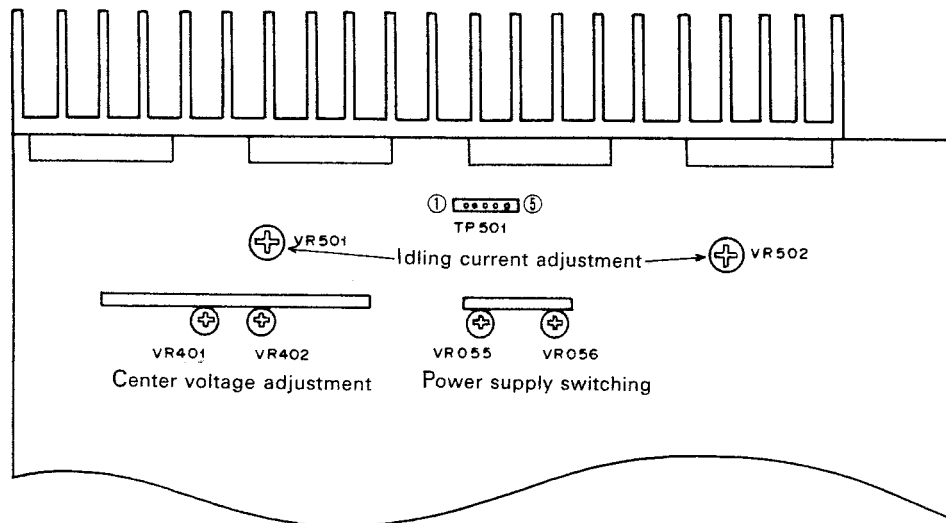

**Note:** On the power transformer of this unit, the power supply P.C. Board is directly connected. When servicing, be careful not to touch the soldered surface.

## Center Voltage Adjustment

Adjust the voltages between the following terminals to  $0 \pm 1$  mV with VR401 (L channel) and VR402 (R channel).

- { PIN③ (ground) -PIN② (L out) on TP501: VR401
- { PIN③ (ground) -PIN④ (R out) on TP501: VR402

## Idling Current Adjustment

- (1) Before turning the power ON, turn the semi-fixed resistors (VR501 for the L channel and VR502 for the R channel) on the power amplifier PC Board fully counterclockwise.
- (2) After turning the power ON, adjust the voltages between PIN① (-) and PIN② (+) and between PIN④ (-) and PIN⑤ (+) on TP501 with the semi-fixed resistors VR501 and VR502.

When adjusting 1 minutes after turning the power ON: 2.1 mV

4.0mV (Except for U.S.A., Canada and W.Germany)

When adjusting 10 minutes after turning the power ON: 8 mV

Confirm that the current is within 6~10 mV when in a stabilized condition.

## Power Supply Switching Circuit Adjustment

This adjustment should be performed with a load of 5 ohms, and confirmed with a load of 6 ohms (no waveform distortion). Touch these VR knobs (VR055, VR056) which are not usually touched. If adjustment is required, perform in the following manner.

1. Before turning the power ON, turn the semi-fixed resistors (VR055 for the L channel and VR056 for the R channel) on the power amplifier PC Board fully counterclockwise.
2. After turning the power ON, apply a 20~40 Hz sine wave to either the L or R channel, and adjust the volume knob so that 31V is output when a 4-ohm dummy load is connected to the speaker terminals (two 8-ohm resistors in parallel). At this time, minimize the input level of the other channel with the BALANCE control.
3. Then, turn the semi-fixed resistor (VR055 for the L channel or VR056 for the R channel) slowly clockwise, and stop when the output waveform begins clipping on the oscilloscope.
4. Replace the 4-ohm load with an 8-ohm one, and check that the output waveform does not clip. This adjustment should be performed for the channels one at a time.

**Note:** Be sure to perform these measurement with the probes and cabinet of the measuring equipment separated from the grounding terminals of the AX-1100BK or other measuring equipment.

# Block Diagram

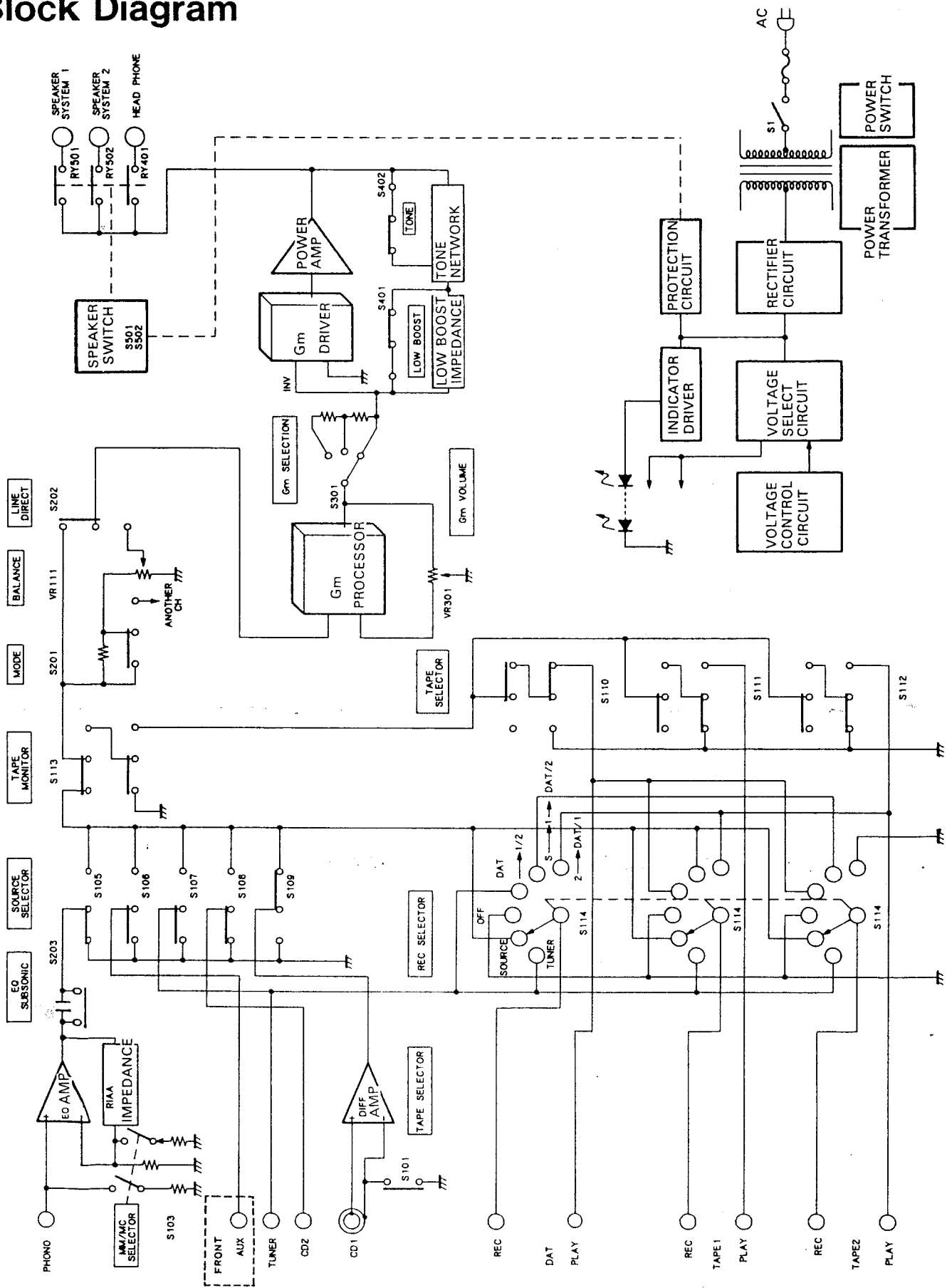

# Connection Diagram

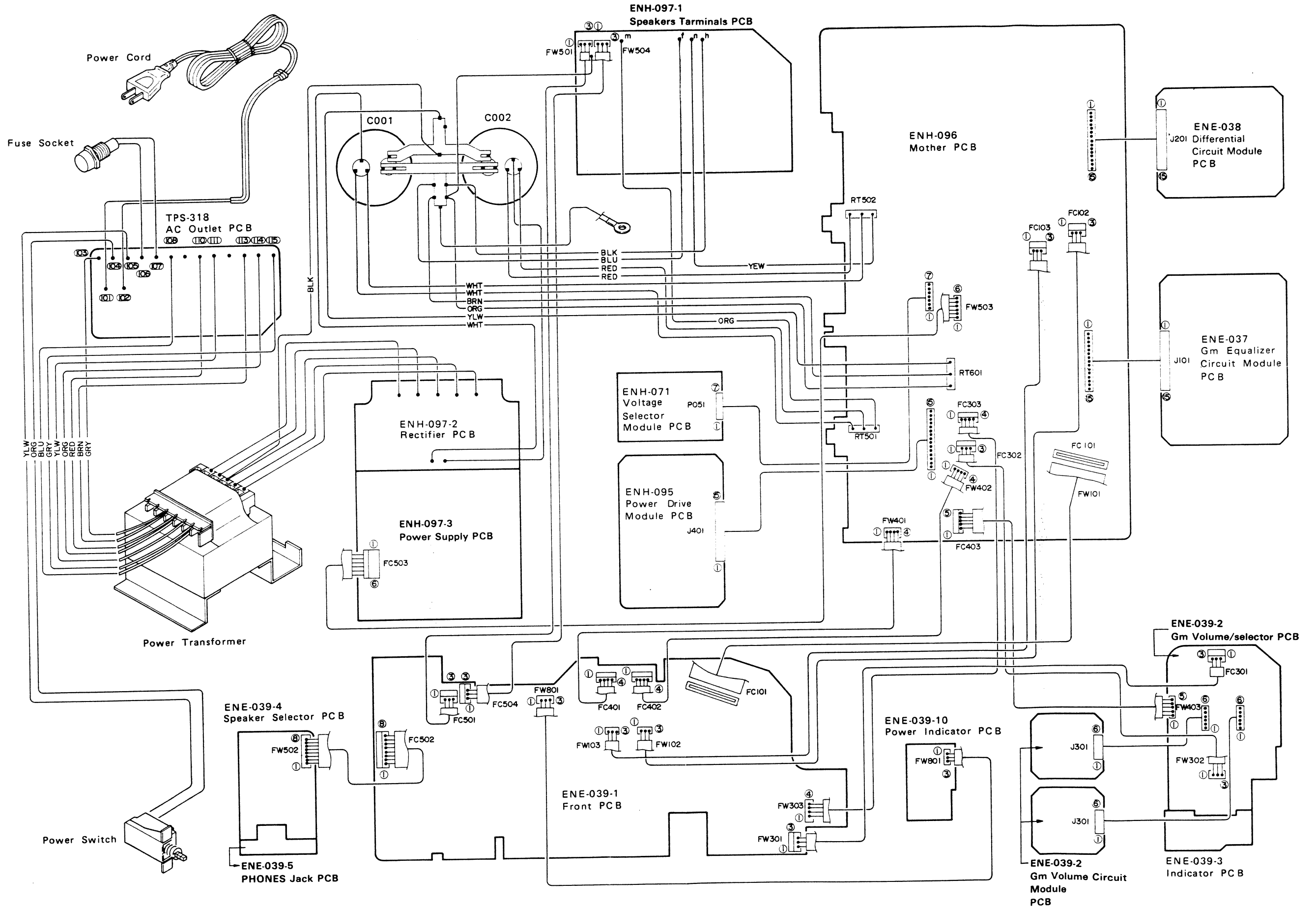



# Schematic Diagram

■ Power Supply Section

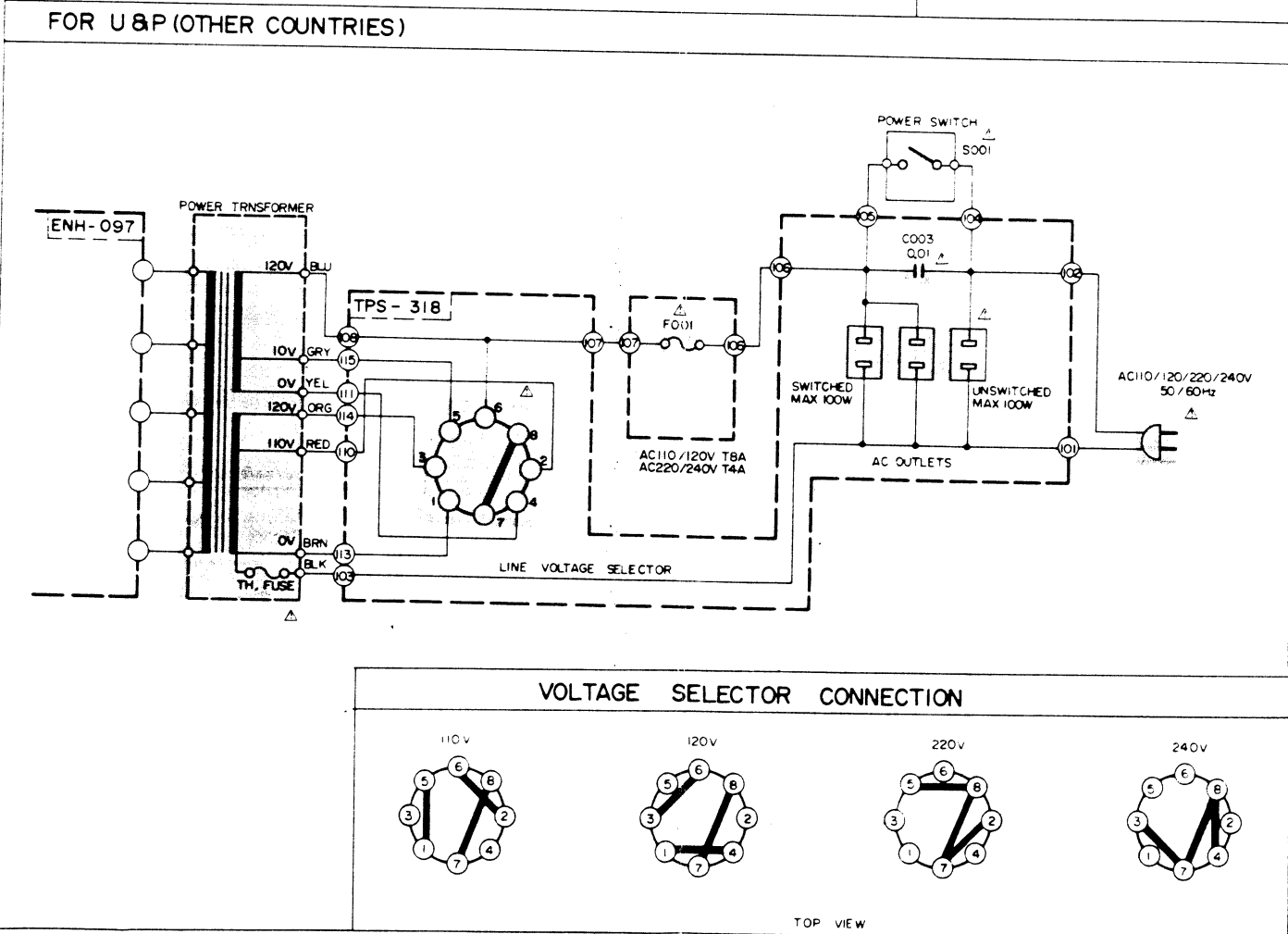
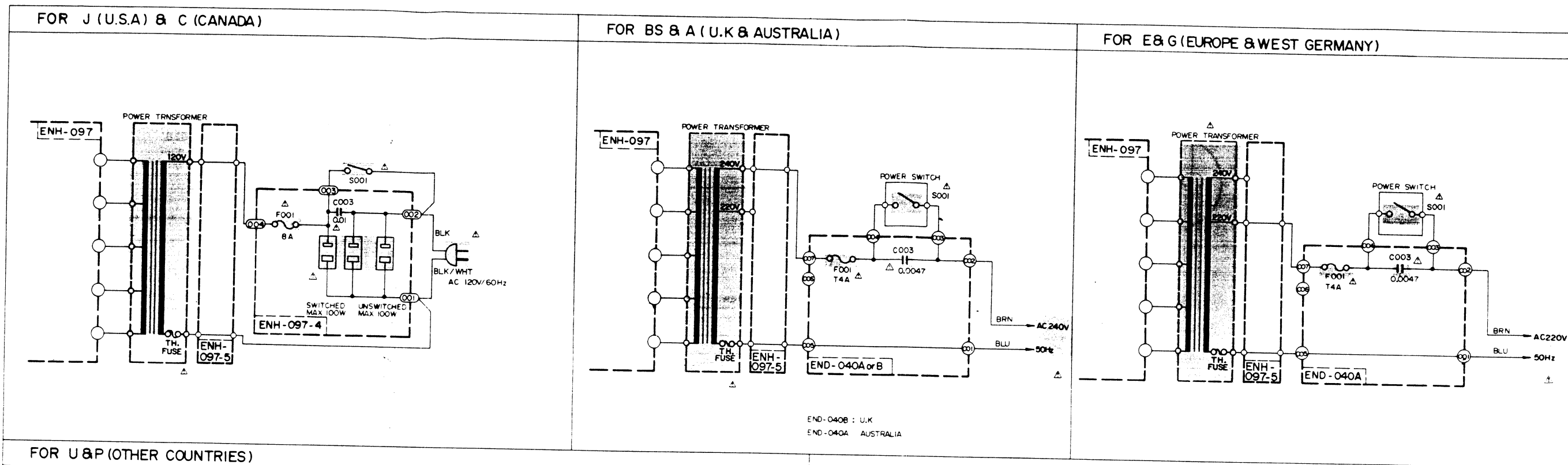

## Internal Block Diagrams of ICs

■ VC5022-2 (IC501, IC502)

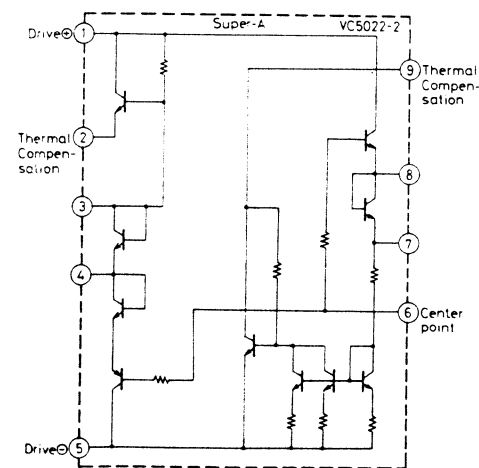

■ AN6912 (IC051)

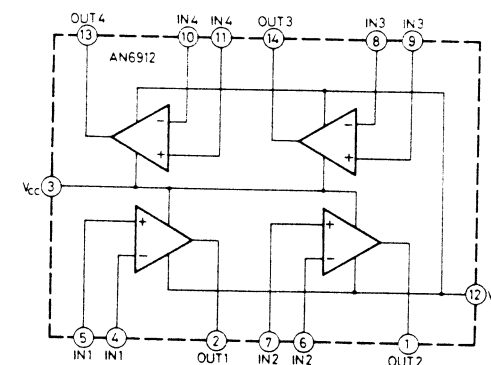

■ TA7317P (IC601)

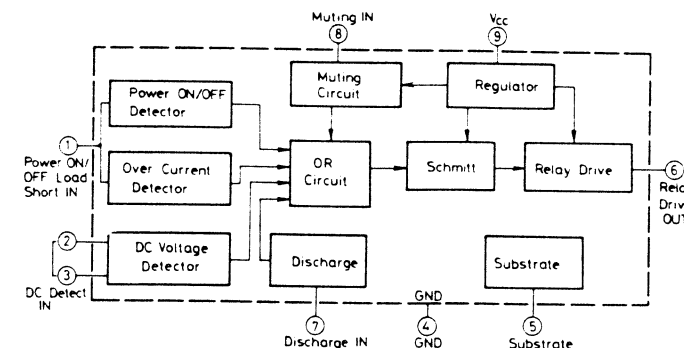

Schematic Diagram ■ Differential Circuit, Equalizer, Selector Section

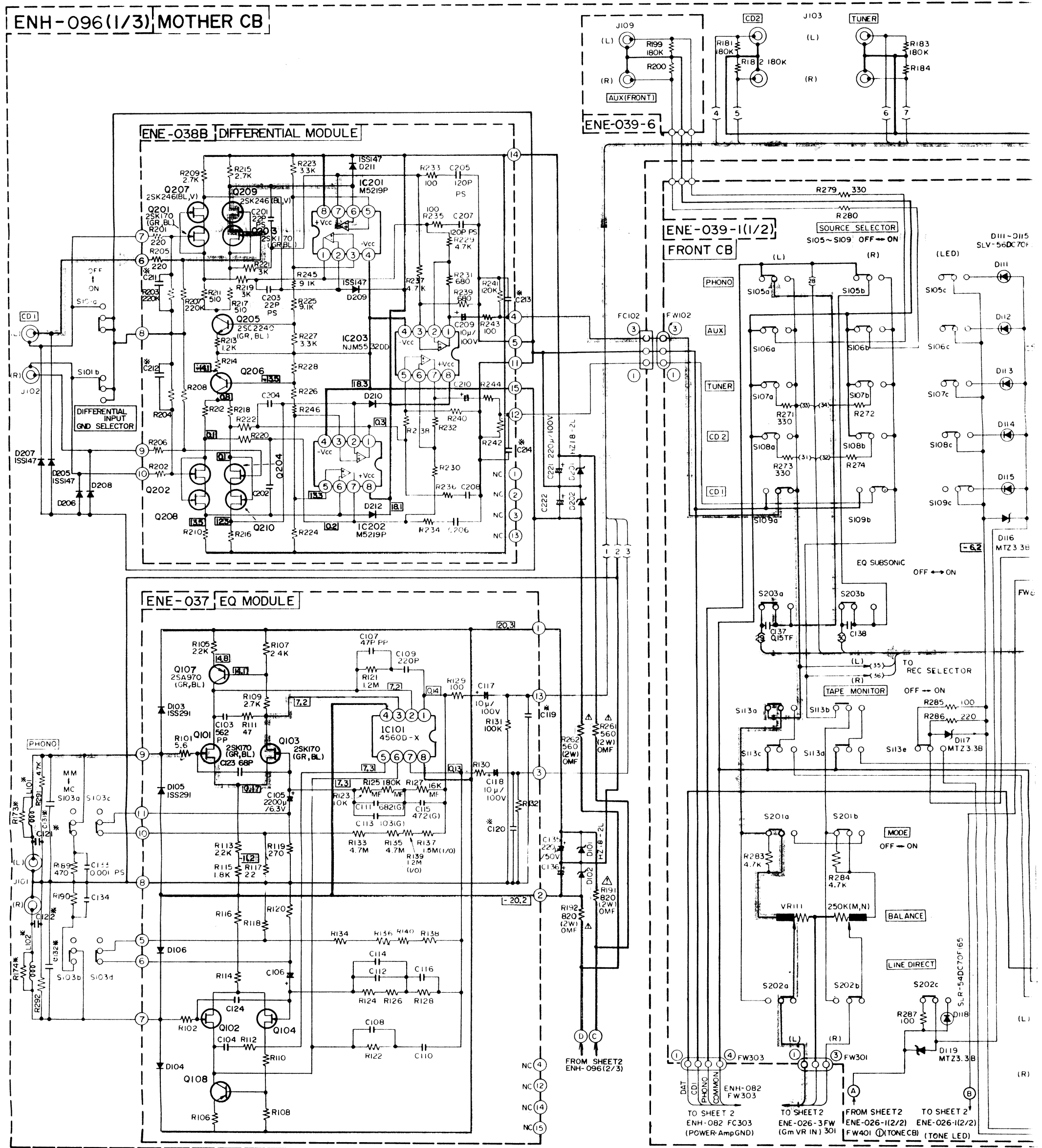

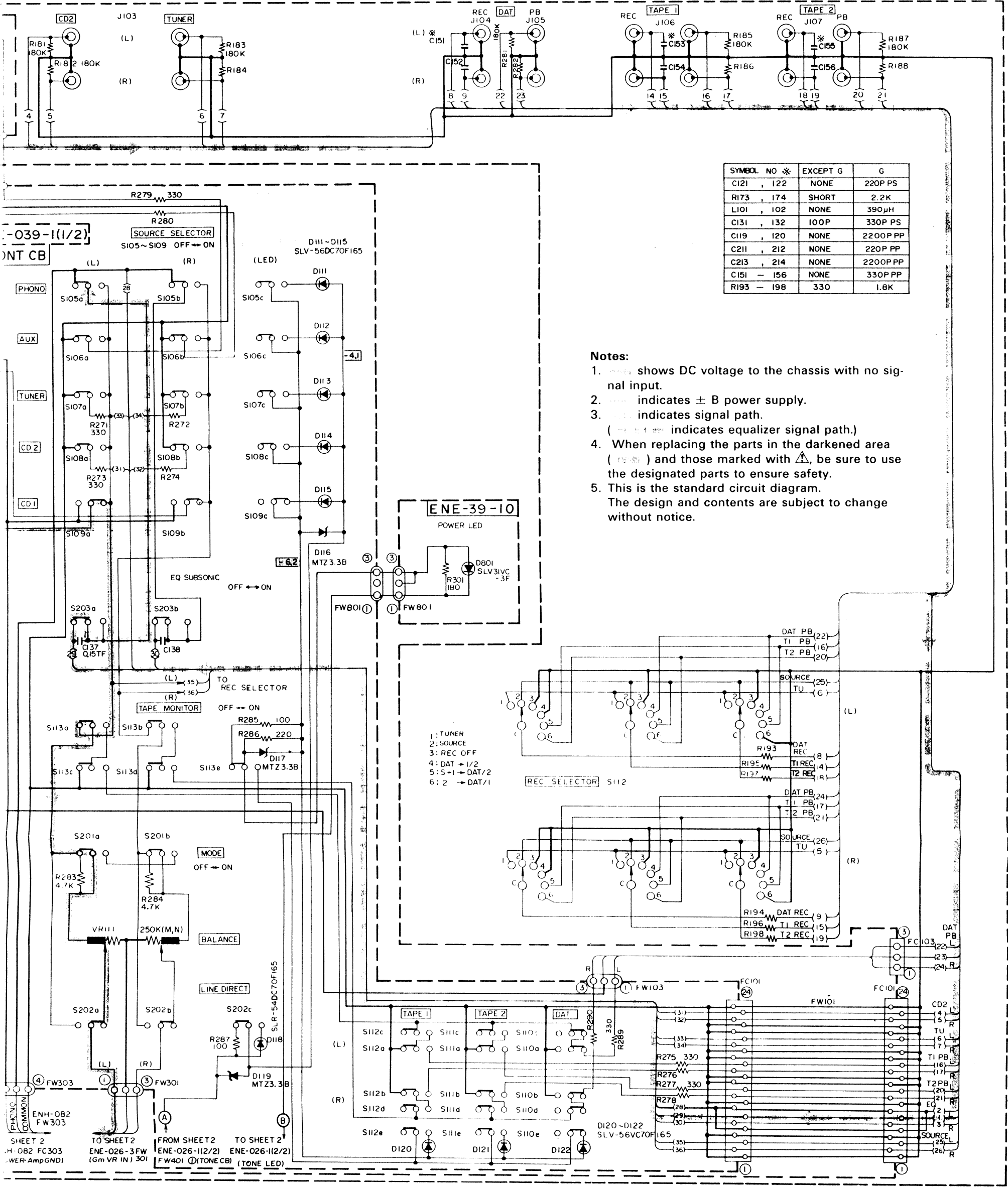

SYMBOL	NO *	EXCEPT G	G
C121	, 122	NONE	220P PS
R173	, 174	SHORT	2.2K
L101	, 102	NONE	390μH
C131	, 132	100P	330P PS
C119	, 120	NONE	2200P PP
C211	, 212	NONE	220P PP
C213	, 214	NONE	2200P PP
C151 - 156		NONE	330P PP
R193 - 198		330	1.8K

- Notes:**
1. shows DC voltage to the chassis with no signal input.
  2. indicates ± B power supply.
  3. indicates signal path.
  4. When replacing the parts in the darkened area ( ) and those marked with  $\Delta$ , be sure to use the designated parts to ensure safety.
  5. This is the standard circuit diagram.
- The design and contents are subject to change without notice.

SHEET 2  
H-082 FC303  
WER-AmpGND)

TO SHEET 2  
ENE-026-3FW  
(Gm VR IN) 301

FROM SHEET 2  
ENE-026-1(2/2)  
FW401 (TONE CB)

TO SHEET 2  
ENE-026-1(2/2)  
(TONE LED)

# Schematic Diagram ■ Power Amplifier, Gm Drive Section

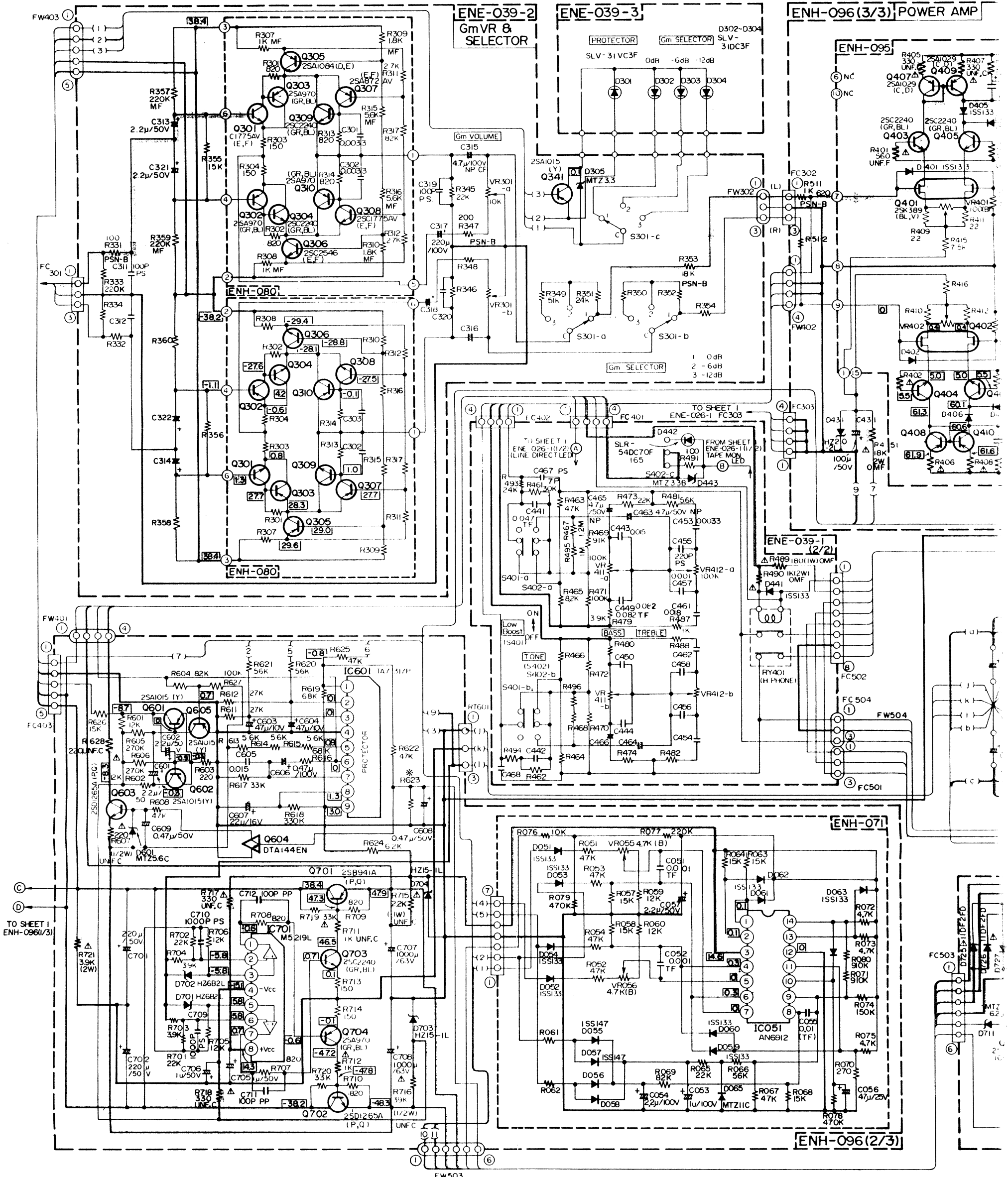

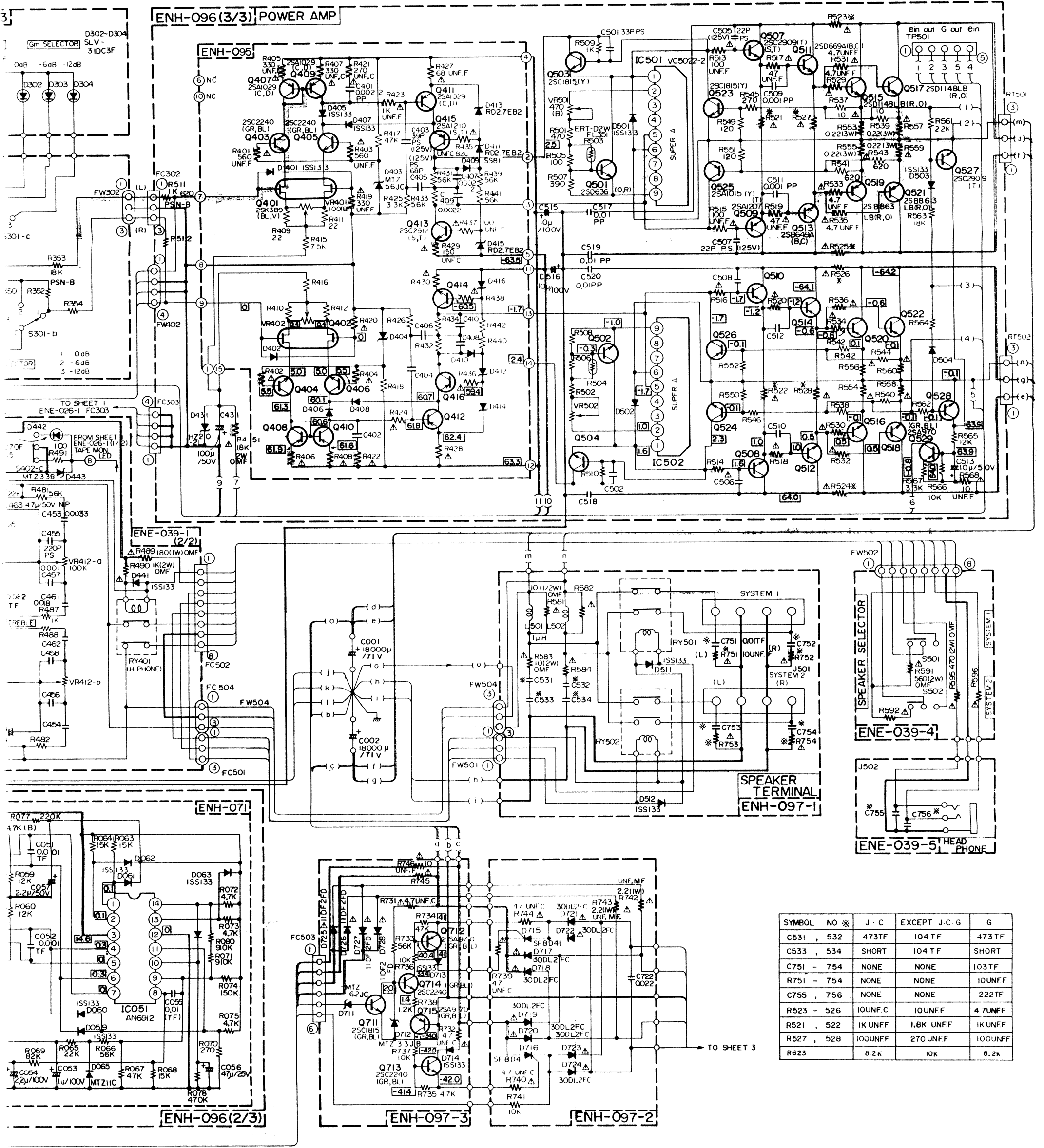

SYMBOL	NO *	J - C	EXCEPT J - C - G	G
C531	532	473TF	104TF	473TF
C533	534	SHORT	104TF	SHORT
C751 - 754	NONE	NONE	NONE	103TF
C755	756	NONE	NONE	222TF
R523 - 526	10UNF C	10UNFF	4.7UNFF	4.7UNFF
R521	522	1K UNFF	1.8K UNFF	1K UNFF
R527	528	100UNFF	270UNFF	100UNFF
R623		8.2K	10K	8.2K

# Exploded View and Parts List

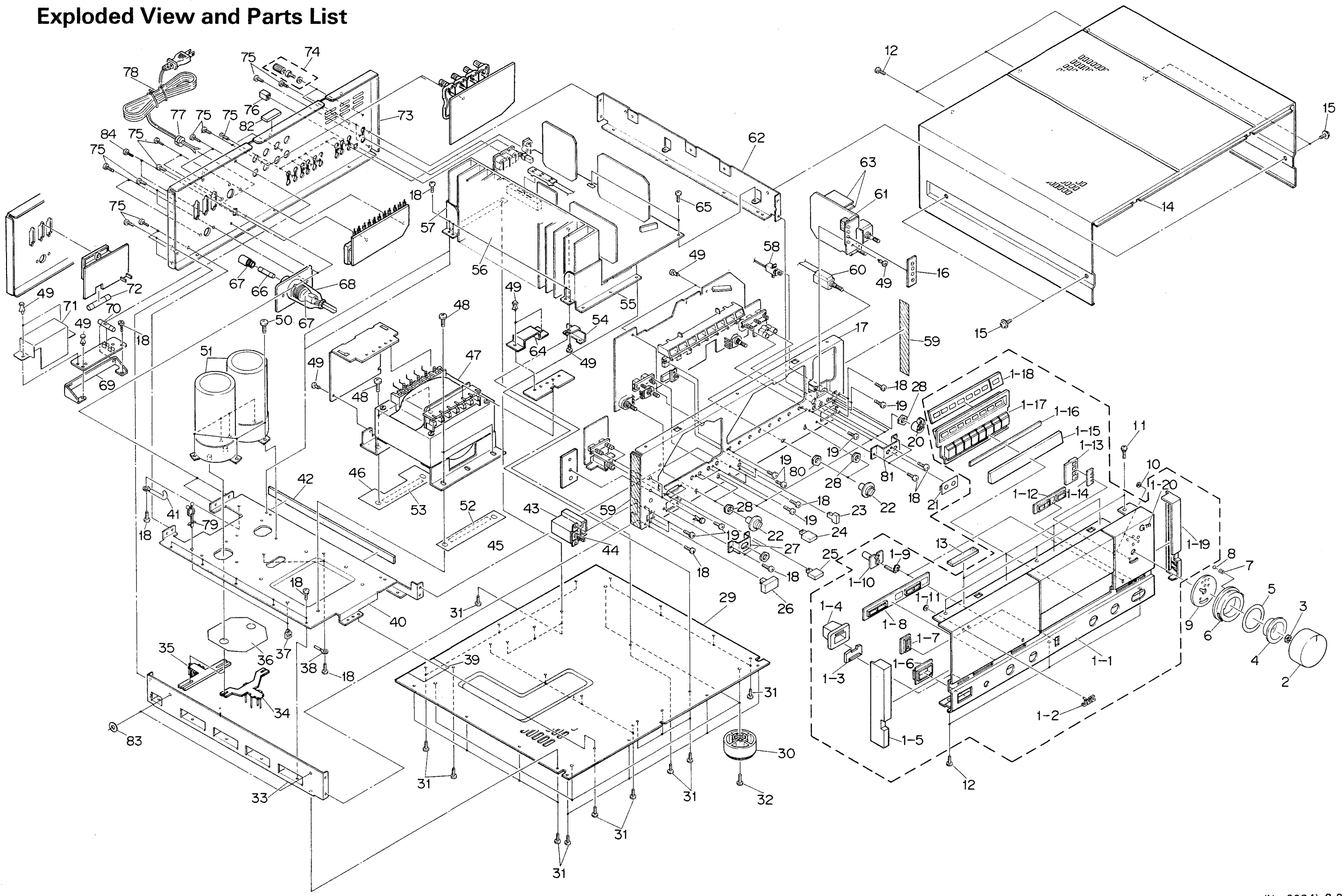

Item	Part Number	Part Name	Q'ty	Description	Areas
1	EFP-AX1100BKE	Front Panel Ass'y	1		
1-1	E11348-003	Front Panel	1		
1-2	E70913-001	JVC Mark	1		
1-3	E73705-001	Indicator	1		
1-4	E304491-001	LED Holder	1		
1-5	E304398-001	Fitting	1	Left	
1-6	E73339-001	Knob Escutcheon	1		
1-7	E73340-001	Knob Escutcheon	1		
1-8	E73342-001	Push Escutcheon	1		
1-9	E73347-002	Indicator	2		
1-10	E73349-002	LED Holder	2		
1-11	E60912-003	Speed Nut	1		
1-12	E73341-001	Push Escutcheon	1		
1-13	E73350-002	LED Holder	1		
1-14	E73348-001	Indicator	1		
1-15	E304346-002	Screen	1		
1-16	E73470-001	Sheet	1		
1-17	E25430-002	Knob Ass'y	1		
1-18	E73687-003	Spacer	1		
1-19	E304398-002	Fitting	1	Right	
1-20	E70978-001	Gm Mark	1		
2	E73702-001	Volume Knob Ass'y	1		
3	E71862-002	Volume Nut	1		
4	E304258-003	Knob Bush	1		
5	E73227-003	Sheet	1		
6	E304254-002	Knob Ring Ass'y	1		
7	E66722-036	Coil Spring	1		
8	E68428-004	Steel Ball	1		
9	E73226-001	Sheet	1		
10	RDS2000F	C.S. Ring	1		
11	E66052-005	Special Screw	3		
12	SDSB3008MCP	Screw	6		
13	EXO055010N50S02	Spacer	4		
14	E25429-002	Metal Cover	1		
15	E73624-001	Special Screw	4		
16	E73688-001	Felt Spacer	1		
17	E11350-002	Front Bracket	1		
18	SBSE3008CC	Screw	19		
19	SBST3006CC	Screw	14		
20	E73228-001	Arm	1		
21	E72519-001	Spacer	1		
22	E73343-001	Knob	4		
23	E73338-001	Push Knob	1		
24	E73337-002	Push Knob	6		
25	E73336-001	Push Knob	2		
26	E73335-001	Power Knob Ass'y	1		
27	E73333-001	Head Phone Bracket	1		
28	E71862-001	Volume Nut	4		
29	E11351-004	Bottom Plate	1		
30	E73346-002	Foot	4		
31	SBSE3008N	Screw	27		
32	E61661-004	Special Screw	4		
33	E25427-004	Frame	1	Left	
34	E73689-001	Earth Plate	1		
35	E73690-001	Earth Plate	1		
36	E73464-002	Sheet	1		
37	E304345-001	Wire Clamp	2		
38	PU49485-1	Wire Clamp	1		
39	E74214-001	Sheet	1		J, C
40	E25426-004	Transformer Base	1		

△: Safety Parts

Item	Part Number	Part Name	Q'ty	Description	Areas
41	EWT011-097	Terminal Wire Ass'y	1		
42	EX0260005N30S02	Spacer	1		
43	E71005-001	Switch Cover	1		
△ 44	QSP1106-005	Power Switch	1	S001	Except BS
△ 44	QSP1106-005BS	Power Switch	1	S001	BS
45	E73591-001	Sheet	1		
46	E73592-001	Sheet	1		
△ 47	ETP1300-03JA	Power Transformer	1		J, C
△ 47	ETP1300-03EA	Power Transformer	1		E, A
△ 47	ETP1300-03XA	Power Transformer	1		G
△ 48	ETP1300-03EABS	Power Transformer	1		BS
△ 48	ETP1300-03FA	Power Transformer	1		P, PG, U
49	E65389-006	Special Screw	1		
49	E48729-003	Plastic Rivet	1		
50	E65389-004	Special Screw	6		
51	EEY7101-189	Electrolytic Capacitor	2	C001, C002	
52	E73591-001	Sheet	1		
53	E73592-001	Sheet	1		
54	E73557-002	Circuit Board Bracket	1		
55	E304343-004	Heat Sink Bracket	1	Rear	
56	E304366-002	Heat Sink	1	Front	
57	E304343-006	Heat Sink Bracket	1		
58	QSH1P07-008	Flex Push Switch	1		
59	E73590-001	Sheet	2		
60	QSH1R03-005	Flex Rotary Switch	1		
61	EXO020010N90S02	Spacer	1		
62	E25428-004	Frame	1	Right	
63	ENH-080B	Circuit Board Ass'y	2		
64	E74177-001	Protect Cover	1		
65	GBSB3008CC	Screw	2		Except P, PG, U
△ 66	QMF51A2-4R0S	Fuse	1		PG, U
△ 66	QMF51A2-8R0L	Fuse	1		P
67	QMG0301-003	Fuse Holder	1		P, PG, U
68	E69291-001	Fuse Cover	1		P, PG, U
69	E71074-002	Bracket	1		E, A, G, BS
△ 70	QMF51A2-4R0S	Fuse	1	F001	E, A, G
△ 70	QMF51E2-4R0SBS	Fuse	1	F001	BS
71	E72922-002	Cover	1		E, A, G, BS
△ 72	QMF61U1-8R0	Fuse	1	F001	J, C
73	E25424-002	Rear Panel	1		J, C
	E25424-006	Rear Panel	1		P, PG, U
	E25424-007	Rear Panel	1		E, A, G, BS
74	E70078-001	GND Terminal	2		
75	SBSB3008MCP	Screw	25		
76	E73578-001	Push Knob	1		
△ 77	QHS3876-162	Cord Stopper	1		Except BS
△ 77	QHS3876-162BS	Cord Stopper	1		BS
△ 78	QMP1480-200H	Power Cord	1		J, C
△ 78	QMP2560-244	Power Cord	1		A
△ 78	QMP3900-200	Power Cord	1		E, G
△ 79	QMP7600-200	Power Cord	1		P, PG, U
△ 79	QMP9017-008BS	Power Cord	1		BS
80	QHW2115-001	Wire Clamp	1		E, A, G, BS
80	E71862-003	Volume Nut	1		
81	E73332-001	Pin Jack Bracket	1		
82	EXO030010N20S02	Spacer	1		J, C, G
83	E69559-009	Spacer	2		J, C, G
84	E74304-001	Screw	2		J, C, P, PG, U
-	E303260-098	Rating Label	1		E, G

△: Safety Parts

The Marks for Designated Areas

J..... U.S.A  
 C..... Canada  
 E..... Europe  
 A..... Australia  
 G..... West Germany  
 BS..... U.K.  
 P,PG..... U.S. Military Market  
 U..... Other Countries  
 No mark indicates all area.

# Printed Circuit Board Ass'y and Parts List

## ■ ENH-096 □ Main Amplifier PC Board Ass'y

Note: ENH-096 □ varies according to the areas employed. See note (1) when placing an order.

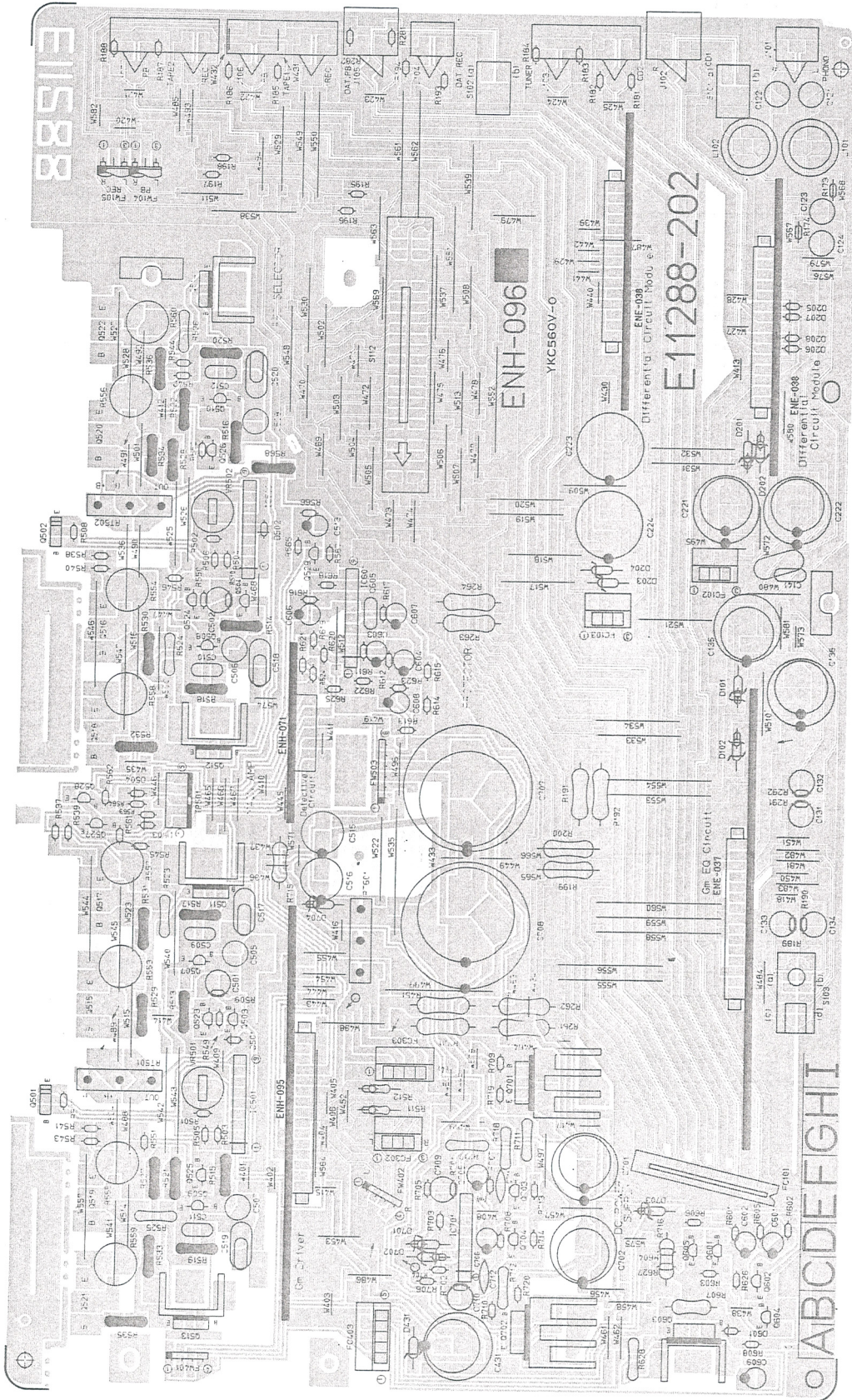



Note (1)

PC Board Ass'y	Designated Areas
ENH-096 <b>A</b>	U.S.A., Canada
ENH-096 <b>B</b>	Europe, Australia, U.K., U.S. Military Market & Other Countries
ENH-096 <b>C</b>	West Germany

TRANSISTORS

ITEM	PART NUMBER	DESCRIPTION		AREA
			MAKER	
Q501	2SD636(Q,R)	SILICON	MATSUSHITA	
Q502	2SD636(Q,R)	SILICON	MATSUSHITA	
Q503	2SC1815(Y)	SILICON	TOSHIBA	
Q504	2SC1815(Y)	SILICON	TOSHIBA	
Q507	2SC2909(T)	SILICON	SANYO	
Q508	2SC2909(T)	SILICON	SANYO	
Q509	2SA1207(T)	SILICON	SANYO	
Q510	2SA1207(T)	SILICON	SANYO	
Q511	2SD669A(B,C)	SILICON	HITACHI	
Q512	2SD669A(B,C)	SILICON	HITACHI	
Q513	2SB649A(B,C)	SILICON	HITACHI	
Q514	2SB649A(B,C)	SILICON	HITACHI	
Q515	2SD1148LB(R,O)	SILICON		
Q516	2SD1148LB(R,O)	SILICON		
Q517	2SD1148LB(R,O)	SILICON		
Q518	2SD1148LB(R,O)	SILICON		
Q519	2SB863LB(O,R)	SILICON	TOSHIBA	
Q520	2SB863LB(O,R)	SILICON	TOSHIBA	
Q521	2SB863LB(O,R)	SILICON	TOSHIBA	
Q522	2SB863LB(O,R)	SILICON	TOSHIBA	
Q523	2SC1815(Y)	SILICON	TOSHIBA	
Q524	2SC1815(Y)	SILICON	TOSHIBA	
Q525	2SA1015(Y)	SILICON	TOSHIBA	
Q526	2SA1015(Y)	SILICON	TOSHIBA	
Q527	2SC2909(T)	SILICON	SANYO	
Q528	2SC2909(T)	SILICON	SANYO	
Q529	2SA970(GR,BL)	SILICON	TOSHIBA	
Q601	2SA1015(Y)	SILICON	TOSHIBA	
Q602	2SA1015(Y)	SILICON	TOSHIBA	
Q603	2SD1265A(P,Q)	SILICON	MATSUSHITA	
Q604	DTA144EN	SILICON	ROHM	
Q605	2SA1015(Y)	SILICON	TOSHIBA	
Q701	2SB941A(P,Q)	SILICON	MATSUSHITA	
Q702	2SD1265A(P,Q)	SILICON	MATSUSHITA	
Q703	2SC2240(GR,BL)	SILICON	TOSHIBA	
Q704	2SA970(GR,BL)	SILICON	TOSHIBA	

I. C. S

ITEM	PART NUMBER	DESCRIPTION		AREA
			MAKER	
IC501	VC5022-2	I.C.	SANYO	
IC502	VC5022-2	I.C.	SANYO	
IC601	TA7317P	I.C.	TOSHIBA	
IC701	M5219L	I.C.	mitsubishi	

DIODES

ITEM	PART NUMBER	DESCRIPTION		AREA
			MAKER	
D101	HZ20-2L	ZENER	HITACHI	
D102	HZ20-2L	ZENER	HITACHI	
D201	HZ18-2L	ZENER	HITACHI	
D202	HZ18-2L	ZENER	HITACHI	
D205	1SS147	SILICON	ROHM	
D206	1SS147	SILICON	ROHM	
D207	1SS147	SILICON	ROHM	
D208	1SS147	SILICON	ROHM	
D431	HZ20-2L	ZENER	HITACHI	
D501	1SS133	SILICON	ROHM	
D502	1SS133	SILICON	ROHM	
D503	1SS133	SILICON	ROHM	
D504	1SS133	SILICON	ROHM	
D601	MTZ5.6JC	ZENER	ROHM	
D701	HZ6B2L	ZENER	HITACHI	
D702	HZ6B2L	ZENER	HITACHI	
D703	HZ15-1L	ZENER	HITACHI	
D704	HZ15-1L	ZENER	HITACHI	

CAPACITORS

ITEM	PART NUMBER	DESCRIPTION			AREA
C121	QFP81HJ-221	220PF	50V	POLY	C
C122	QFP81HJ-221	220PF	50V	POLY	C
C131	QFP81HJ-101	100PF	50V	POLY	A
C131	QFP81HJ-101	100PF	50V	POLY	B
C131	QFP81HJ-331	330PF	50V	POLY	C
C132	QFP81HJ-101	100PF	50V	POLY	A
C132	QFP81HJ-101	100PF	50V	POLY	B
C132	QFP81HJ-331	330PF	50V	POLY	C
C133	QFS81HJ-102	1000PF	50V	POLYSTYROL	
C134	QFS81HJ-102	1000PF	50V	POLYSTYROL	
C135	QETB1HM-227H	220MF	50V	ELECTRO	
C136	QETB1HM-227H	220MF	50V	ELECTRO	
C141	QFN81HJ-103	0.01MF	50V	MYLAR	
C151	QFP81HJ-331	330PF	50V	POLY	C
C152	QFP81HJ-331	330PF	50V	POLY	C
C153	QFP81HJ-331	330PF	50V	POLY	C
C154	QFP81HJ-331	330PF	50V	POLY	C
C155	QFP81HJ-331	330PF	50V	POLY	C
C156	QFP81HJ-331	330PF	50V	POLY	C
C221	QETB2AM-227H	220MF	100V	ELECTRO	
C222	QETB2AM-227H	220MF	100V	ELECTRO	
C431	QETB1HM-107H	100MF	50V	ELECTRO	
C501	QFS81HJ-330	33PF	50V	POLYSTYROL	
C502	QFS81HJ-330	33PF	50V	POLYSTYROL	
C505	QFS82BJ-220	22PF	125V	POLYSTYROL	
C506	QFS82BJ-220	22PF	125V	POLYSTYROL	
C507	QFS82BJ-220	22PF	125V	POLYSTYROL	
C508	QFS82BJ-220	22PF	125V	POLYSTYROL	
C509	QFP81HJ-102	1000PF	50V	POLY	
C510	QFP81HJ-102	1000PF	50V	POLY	
C511	QFP81HJ-102	1000PF	50V	POLY	
C512	QFP81HJ-102	1000PF	50V	POLY	
C513	QETB1HM-106	10MF	50V	ELECTRO	
C515	EEZ42AM-106	10MF	100V	ELECTRO	
C516	EEZ42AM-106	10MF	100V	ELECTRO	
C517	QFP82AJ-103	0.01MF	100V	POLY	
C518	QFP82AJ-103	0.01MF	100V	POLY	
C519	QFP82AJ-103	0.01MF	100V	POLY	
C520	QFP82AJ-103	0.01MF	100V	POLY	
C601	QETB1HM-225	2.2MF	50V	ELECTRO	
C602	QETB1HM-225	2.2MF	50V	ELECTRO	
C603	QETB1AM-476	47MF	10V	ELECTRO	
C604	QETB1AM-476	47MF	10V	ELECTRO	
C605	QFN81HJ-153	0.015MF	50V	MYLAR	
C606	QETB2AM-474	0.47MF	100V	ELECTRO	
C607	QETB1CM-226	22MF	16V	ELECTRO	
C608	QETB1HM-474	0.47MF	50V	ELECTRO	
C609	QETB1HM-474	0.47MF	50V	ELECTRO	
C701	QETB1HM-227H	220MF	50V	ELECTRO	
C702	QETB1HM-227H	220MF	50V	ELECTRO	
C705	QETB1HM-105	1MF	50V	ELECTRO	
C706	QETB1HM-105	1MF	50V	ELECTRO	
C707	EEW6305-108	1000MF		ELECTRO	
C708	EEW6305-108	1000MF		ELECTRO	
C709	QFS81HJ-102	1000PF	50V	POLYSTYROL	
C710	QFS81HJ-102	1000PF	50V	POLYSTYROL	
C711	QFP81HJ-101	100PF	50V	POLY	
C712	QFP81HJ-101	100PF	50V	POLY	

Δ : SAFETY PARTS

RESISTORS

△	ITEM	PART NUMBER	DESCRIPTION			AREA
	R173	QRD167J-222	2.2K	1/6W	CARBON	C
	R174	QRD167J-222	2.2K	1/6W	CARBON	C
	R181	QRD167J-184	180K	1/6W	CARBON	
	R182	QRD167J-184	180K	1/6W	CARBON	
	R183	QRD167J-184	180K	1/6W	CARBON	
	R184	QRD167J-184	180K	1/6W	CARBON	
	R185	QRD167J-184	180K	1/6W	CARBON	
	R186	QRD167J-184	180K	1/6W	CARBON	
	R187	QRD167J-184	180K	1/6W	CARBON	
	R188	QRD167J-184	180K	1/6W	CARBON	
	R189	QRD167J-471	470	1/6W	CARBON	
	R190	QRD167J-471	470	1/6W	CARBON	
△	R191	QRG022J-821A	820	2W	O.M.FILM	
△	R192	QRG022J-821A	820	2W	O.M.FILM	
	R193	QRD167J-182	1.8K	1/6W	CARBON	C
	R193	QRD167J-331	330	1/6W	CARBON	A
	R193	QRD167J-331	330	1/6W	CARBON	B
	R194	QRD167J-182	1.8K	1/6W	CARBON	C
	R194	QRD167J-331	330	1/6W	CARBON	A
	R194	QRD167J-331	330	1/6W	CARBON	B
	R195	QRD167J-182	1.8K	1/6W	CARBON	C
	R195	QRD167J-331	330	1/6W	CARBON	A
	R195	QRD167J-331	330	1/6W	CARBON	B
	R196	QRD167J-182	1.8K	1/6W	CARBON	C
	R196	QRD167J-331	330	1/6W	CARBON	A
	R196	QRD167J-331	330	1/6W	CARBON	B
	R197	QRD167J-182	1.8K	1/6W	CARBON	C
	R197	QRD167J-331	330	1/6W	CARBON	A
	R197	QRD167J-331	330	1/6W	CARBON	B
	R198	QRD167J-182	1.8K	1/6W	CARBON	C
	R198	QRD167J-331	330	1/6W	CARBON	A
	R198	QRD167J-331	330	1/6W	CARBON	B
△	R261	QRG022J-561A	560	2W	O.M.FILM	
△	R262	QRG022J-561A	560	2W	O.M.FILM	
	R281	QRD167J-184	180K	1/6W	CARBON	
	R282	QRD167J-184	180K	1/6W	CARBON	
	R291	QRD167J-473	47K	1/6W	CARBON	
	R292	QRD167J-473	47K	1/6W	CARBON	
△	R451	QRG022J-182A	1.8K	2W	O.M.FILM	
	R501	QRD167J-471	470	1/6W	CARBON	
	R502	QRD167J-471	470	1/6W	CARBON	
	R503	ERT-D2WFL351S	350	1/4W	THERMISTOR	
	R504	ERT-D2WFL351S	350	1/4W	THERMISTOR	
	R505	QRD167J-101	100	1/6W	CARBON	
	R506	QRD167J-101	100	1/6W	CARBON	
	R507	QRD167J-391	390	1/6W	CARBON	
	R508	QRD167J-391	390	1/6W	CARBON	
	R509	QRD167J-102	1K	1/6W	CARBON	
	R510	QRD167J-102	1K	1/6W	CARBON	
	R511	ERD141J-621S	620	1/4W	CARBON	
	R512	ERD141J-621S	620	1/4W	CARBON	
△	R513	QRZ0077-101	100	1/4W	FUSIBLE	
△	R514	QRZ0077-101	100	1/4W	FUSIBLE	
△	R515	QRZ0077-101	100	1/4W	FUSIBLE	
△	R516	QRZ0077-101	100	1/4W	FUSIBLE	
△	R517	QRZ0077-470	47	1/4W	FUSIBLE	
△	R518	QRZ0077-470	47	1/4W	FUSIBLE	
△	R519	QRZ0077-470	47	1/4W	FUSIBLE	
△	R520	QRZ0077-470	47	1/4W	FUSIBLE	
△	R521	QRZ0077-102	1K	1/4W	FUSIBLE	A
△	R521	QRZ0077-102	1K	1/4W	FUSIBLE	B
△	R521	QRZ0077-182	1.8K	1/4W	FUSIBLE	A
△	R522	QRZ0077-102	1K	1/4W	FUSIBLE	B
△	R522	QRZ0077-102	1K	1/4W	FUSIBLE	C
△	R522	QRZ0077-182	1.8K	1/4W	FUSIBLE	B
△	R523	QRD14CJ-100S	10	1/4W	UNF. CARBON	A
△	R523	QRZ0077-100	10	1/4W	FUSIBLE	B
△	R523	QRZ0077-4R7	4.7	1/4W	FUSIBLE	C
△	R524	QRD14CJ-100S	10	1/4W	UNF. CARBON	A
△	R524	QRZ0077-100	10	1/4W	FUSIBLE	B
△	R524	QRZ0077-4R7	4.7	1/4W	FUSIBLE	C
△	R525	QRD14CJ-100S	10	1/4W	UNF. CARBON	A
△	R525	QRZ0077-100	10	1/4W	FUSIBLE	B
△	R525	QRZ0077-4R7	4.7	1/4W	FUSIBLE	C
△	R526	QRD14CJ-100S	10	1/4W	UNF. CARBON	A
△	R526	QRZ0077-100	10	1/4W	FUSIBLE	B
△	R526	QRZ0077-4R7	4.7	1/4W	FUSIBLE	C
△	R527	QRZ0077-101	100	1/4W	FUSIBLE	A
△	R527	QRZ0077-101	100	1/4W	FUSIBLE	B
△	R527	QRZ0077-271	270	1/4W	FUSIBLE	C
△	R528	QRZ0077-101	100	1/4W	FUSIBLE	A
△	R528	QRZ0077-101	100	1/4W	FUSIBLE	C
△	R528	QRZ0077-271	270	1/4W	FUSIBLE	B
△	R529	QRZ0077-4R7	4.7	1/4W	FUSIBLE	
△	R530	QRZ0077-4R7	4.7	1/4W	FUSIBLE	
△	R531	QRZ0077-4R7	4.7	1/4W	FUSIBLE	
△	R532	QRZ0077-4R7	4.7	1/4W	FUSIBLE	
△	R533	QRZ0077-4R7	4.7	1/4W	FUSIBLE	
△	R534	QRZ0077-4R7	4.7	1/4W	FUSIBLE	
△	R535	QRZ0077-4R7	4.7	1/4W	FUSIBLE	
△	R536	QRZ0077-4R7	4.7	1/4W	FUSIBLE	
	R537	QRD167J-100	10	1/6W	CARBON	
	R538	QRD167J-100	10	1/6W	CARBON	
	R539	QRD167J-100	10	1/6W	CARBON	
	R540	QRD167J-100	10	1/6W	CARBON	

RESISTORS

△	ITEM	PART NUMBER	DESCRIPTION			AREA
	R541	QRD167J-621	620	1/6W	CARBON	
	R542	QRD167J-621	620	1/6W	CARBON	
	R543	QRD167J-621	620	1/6W	CARBON	
	R544	QRD167J-621	620	1/6W	CARBON	
	R545	QRD167J-271	270	1/6W	CARBON	
	R546	QRD167J-271	270	1/6W	CARBON	
	R549	QRD167J-121	120	1/6W	CARBON	
	R550	QRD167J-121	120	1/6W	CARBON	
	R551	QRD167J-121	120	1/6W	CARBON	
	R552	QRD167J-121	120	1/6W	CARBON	
△	R553	ERZ0001-R22	0.22	3W	EMITTER	
△	R554	ERZ0001-R22	0.22	3W	EMITTER	
△	R555	ERZ0001-R22	0.22	3W	EMITTER	
△	R556	ERZ0001-R22	0.22	3W	EMITTER	
△	R557	ERZ0001-R22	0.22	3W	EMITTER	
△	R558	ERZ0001-R22	0.22	3W	EMITTER	
△	R559	ERZ0001-R22	0.22	3W	EMITTER	
△	R560	ERZ0001-R22	0.22	3W	EMITTER	
	R561	QRD167J-222	2.2K	1/6W	CARBON	
	R562	QRD167J-222	2.2K	1/6W	CARBON	
	R563	QRD167J-183	18K	1/6W	CARBON	
	R564	QRD167J-183	18K	1/6W	CARBON	
	R565	QRD167J-123	12K	1/6W	CARBON	
	R566	QRD167J-103	10K	1/6W	CARBON	
	R567	QRD167J-332	3.3K	1/6W	CARBON	
△	R568	QRZ0077-100	10	1/4W	FUSIBLE	
	R601	QRD167J-123	12K	1/6W	CARBON	
	R602	QRD167J-123	12K	1/6W	CARBON	
	R603	QRD167J-221	220	1/6W	CARBON	
	R604	QRD167J-823	82K	1/6W	CARBON	
	R605	QRD167J-274	270K	1/6W	CARBON	
	R606	QRD167J-274	270K	1/6W	CARBON	
△	R607	QRD125J-221	220	1/2W	UNF. CARBON	
	R608	QRD167J-473	47K	1/6W	CARBON	
	R611	QRD167J-273	27K	1/6W	CARBON	
	R612	QRD167J-273	27K	1/6W	CARBON	
	R613	QRD167J-562	5.6K	1/6W	CARBON	
	R614	QRD167J-562	5.6K	1/6W	CARBON	
	R615	QRD167J-562	5.6K	1/6W	CARBON	
	R616	QRD167J-683	68K	1/6W	CARBON	
	R617	QRD167J-333	33K	1/6W	CARBON	
	R618	QRD167J-334	330K	1/6W	CARBON	
	R619	QRD167J-683	68K	1/6W	CARBON	
	R620	QRD167J-563	56K	1/6W	CARBON	
	R621	QRD167J-563	56K	1/6W	CARBON	
	R622	QRD167J-473	47K	1/6W	CARBON	
	R623	QRD167J-103	10K	1/6W	CARBON	
	R623	QRD167J-822	8.2K	1/6W	CARBON	B
	R623	QRD167J-822	8.2K	1/6W	CARBON	A
	R624	QRD167J-622	6.2K	1/6W	CARBON	C
	R625	QRD167J-473	47K	1/6W	CARBON	
	R626	QRD167J-153	15K	1/6W	CARBON	
	R627	QRD167J-104	100K	1/6W	CARBON	
△	R628	QRD14CJ-221S	220	1/4W	UNF. CARBON	
	R701	QRD167J-223	22K	1/6W	CARBON	
	R702	QRD167J-223	22K	1/6W	CARBON	
	R703	QRD167J-392	3.9K	1/6W	CARBON	
	R704	QRD167J-392	3.9K	1/6W	CARBON	
	R705	QRD167J-123	12K	1/6W	CARBON	
	R706	QRD167J-123	12K	1/6W	CARBON	
	R707	QRD167J-821	820	1/6W	CARBON	
	R708	QRD167J-821	820	1/6W	CARBON	
	R709	QRD167J-821	820	1/6W	CARBON	
	R710	QRD167J-821	820	1/6W	CARBON	
△	R711	QRD14CJ-102S	1K	1/4W	UNF. CARBON	
△	R712	QRD14CJ-102S	1K	1/4W	UNF. CARBON	
	R713	QRD167J-151	150	1/6W	CARBON	
	R714	QRD167J-151	150	1/6W	CARBON	
△	R715	QRG012J-222AF	2.2K	1W	O.M.FILM	
△	R716	QRD125J-392	3.9K	1/2W	UNF. CARBON	
△	R717	QRD14CJ-331S	330	1/4W	UNF. CARBON	
△	R718	QRD14CJ-331S	330	1/4W	UNF. CARBON	
	R719	QRD167J-333	33K	1/6W	CARBON	
	R720	QRD167J-333	33K	1/6W	CARBON	
△	R721	QRG012J-392AF	3.9K	1W	O.M.FILM	
	VR501	QVP4A0B-471	470	0.15W	VARIABLE	
	VR502	QVP4A0B-471	470	0.15W	VARIABLE	

△ : SAFETY PARTS

OTHERS

ITEM	PART NUMBER	DESCRIPTION	AREA
	BUSH-PUL	BUSHING	
	ENZ2006-001	SHIELD CASE ASS'Y	C
	E11288-202	CIRCUIT BOARD	
	E304343-004	HEAT SINK BRACKET	
	E304343-006	HEAT SINK BRACKET	
	E304366-002	HEAT SINK	
	E70306-003	HEAT SINK	
	E70306-003	HEAT SINK	
	E70859-001	EARTH PLATE	
	E70945-H35B	HEAT SINK	
	E73525-001	SCREW	
	E73698-001	SPACER	
	GBSB3008CC	SCREW	
	G746		
	SBSB3008CC	SCREW	
	SBSB3008CC	SCREW	
	SBSB3008CC	SCREW	
	SBSE3010CC	SCREW	
J101	EMN00TV-202A	2P PIN JACK	
J102	EMN00TV-206A	2P PIN JACK	

OTHERS

ITEM	PART NUMBER	DESCRIPTION	AREA
J103	EMN00TV-403A	4P PIN JACK	
J106	EMN00TV-403A	4P PIN JACK	
J107	EMN00TV-403A	4P PIN JACK	
L101	EQL0111-391	INDUCTOR	C
L102	EQL0111-391	INDUCTOR	C
S101	QST3101-E06	PUSH SWITCH	
S103	QSS4201-504	SLIDE SWITCH	
S112	QSS6501-001	SLIDE SWITCH	
FC101	EMV7111-024	CONNECTOR	
FC102	EMV7112-003	CONNECTOR	
FC103	EMV7112-003	CONNECTOR	
FC302	EMV7112-003	CONNECTOR	
FC303	EMV7112-004	CONNECTOR	
FC403	EMV7112-005	CONNECTOR	
RT501	E67764-503	WRAPPING TERMINAL	
RT502	E67764-503	WRAPPING TERMINAL	
RT601	E67764-503	WRAPPING TERMINAL	
TP501	QMV5005-005K	PLUG ASSY	
J104	EMN00TV-202A	2P PIN JACK	
J105	EMN00TV-206A	2P PIN JACK	

△ : SAFETY PARTS

■ ENH-097 □ Power Supply PC Board Ass'y

Note: ENH-097 □ varies according to the areas employed. See note (1) when placing an order.

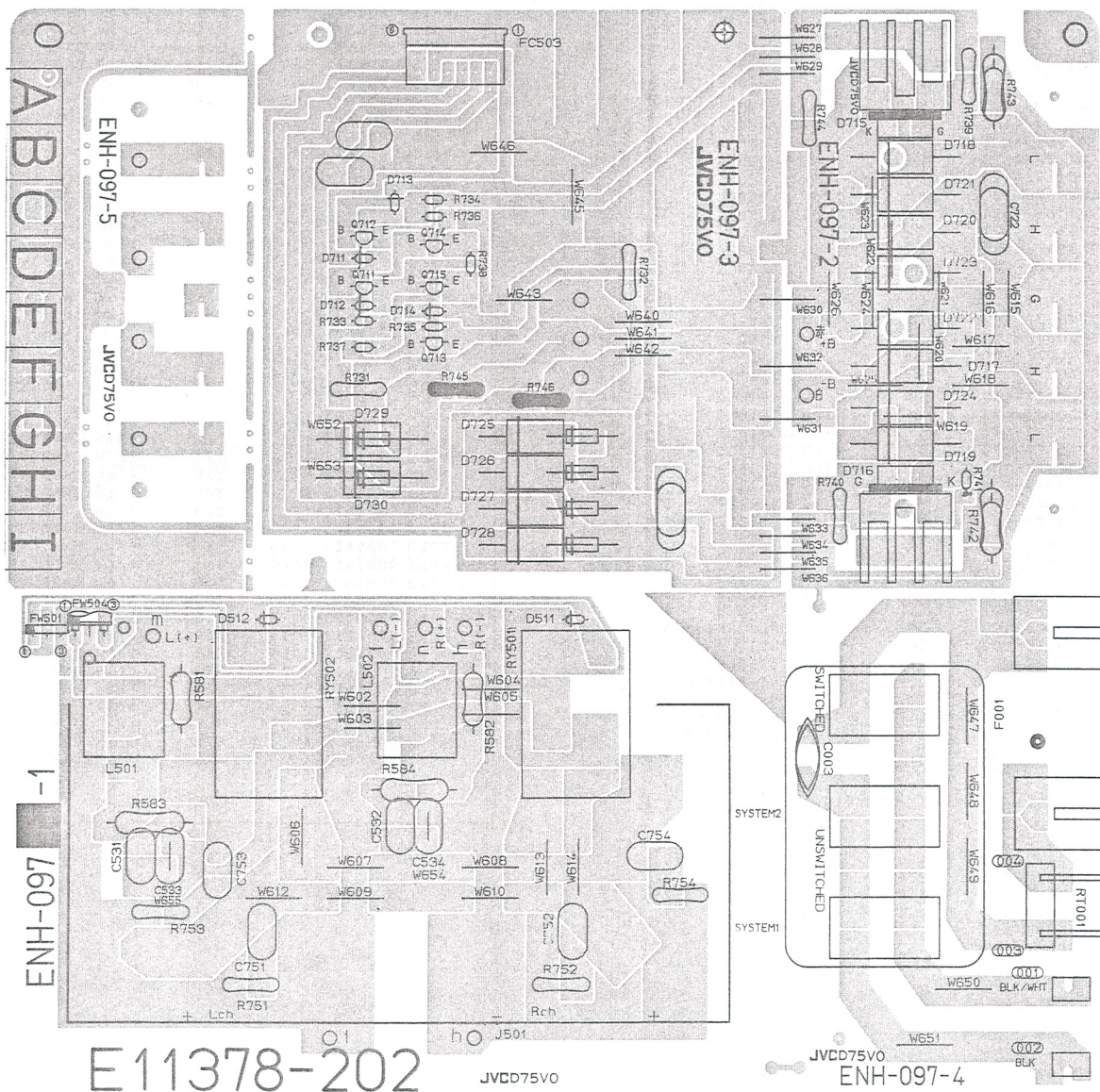

Note (1)

PC Board Ass'y	Dsignated Areas
ENH-097 <b>A</b>	U.S.A., Canada
ENH-097 <b>B</b> BS	U.K.
ENH-097 <b>C</b>	West Germany
ENH-097 <b>D</b>	Australia
ENH-097 <b>E</b>	Europe
ENH-097 <b>F</b>	U.S.Military Market & Other Countries

TRANSISTORS

ITEM	PART NUMBER	DESCRIPTION		AREA
			MAKER	
Q711	2SC1815(GR,BL)	SILICON	TOSHIBA	
Q712	2SA970(GR,BL)	SILICON	TOSHIBA	
Q713	2SC2240(GR,BL)	SILICON	TOSHIBA	
Q714	2SC2240(GR,BL)	SILICON	TOSHIBA	
Q715	2SA970(GR,BL)	SILICON	TOSHIBA	

DIODES

ITEM	PART NUMBER	DESCRIPTION		AREA
			MAKER	
D511	1SS133	SILICON	ROHM	
D512	1SS133	SILICON	ROHM	
D711	MTZ6.2JC	ZENER	ROHM	
D712	MTZ3.3JB	ZENER	ROHM	
D713	1SS133	SILICON	ROHM	
D714	1SS133	SILICON	ROHM	
D715	SF8D41		TOSHIBA	
D716	SF8D41		TOSHIBA	
D717	3ODL2FC	SILICON	NIHONINTER	
D718	3ODL2FC	SILICON	NIHONINTER	
D719	3ODL2FC	SILICON	NIHONINTER	
D720	3ODL2FC	SILICON	NIHONINTER	
D721	3ODL2FC	SILICON	NIHONINTER	
D722	3ODL2FC	SILICON	NIHONINTER	
D723	3ODL2FC	SILICON	NIHONINTER	
D724	3ODL2FC	SILICON	NIHONINTER	
D725	11DF2FD	ZENER	NIHONINTER	
D726	11DF2FD	ZENER	NIHONINTER	
D727	11DF2FD	ZENER	NIHONINTER	
D728	11DF2FD	ZENER	NIHONINTER	

CAPACITORS

ITEM	PART NUMBER	DESCRIPTION		AREA
C003	QCZ9038-103	0.01MF	CERAMIC	A
C531	QFV81HJ-104	0.1MF	50V T.FILM	BBS
C531	QFV81HJ-104	0.1MF	50V T.FILM	D
C531	QFV81HJ-104	0.1MF	50V T.FILM	E
C531	QFV81HJ-104	0.1MF	50V T.FILM	F
C531	QFV81HJ-473	0.047MF	50V T.FILM	A
C531	QFV81HJ-473	0.047MF	50V T.FILM	C
C532	QFV81HJ-104	0.1MF	50V T.FILM	BBS
C532	QFV81HJ-104	0.1MF	50V T.FILM	D
C532	QFV81HJ-104	0.1MF	50V T.FILM	E
C532	QFV81HJ-104	0.1MF	50V T.FILM	F
C532	QFV81HJ-473	0.047MF	50V T.FILM	A
C532	QFV81HJ-473	0.047MF	50V T.FILM	C
C533	QFV81HJ-104	0.1MF	50V T.FILM	BBS
C533	QFV81HJ-104	0.1MF	50V T.FILM	D
C533	QFV81HJ-104	0.1MF	50V T.FILM	E
C533	QFV81HJ-104	0.1MF	50V T.FILM	F
C534	QFV81HJ-104	0.1MF	50V T.FILM	BBS
C534	QFV81HJ-104	0.1MF	50V T.FILM	D
C534	QFV81HJ-104	0.1MF	50V T.FILM	E
C534	QFV81HJ-104	0.1MF	50V T.FILM	F
C722	EFZ0091-223	0.022MF	630V M.MYLAR	
C751	QFV81HJ-103	0.01MF	50V T.FILM	C
C752	QFV81HJ-103	0.01MF	50V T.FILM	C
C753	QFV81HJ-103	0.01MF	50V T.FILM	C
C754	QFV81HJ-103	0.01MF	50V T.FILM	C

RESISTORS

ITEM	PART NUMBER	DESCRIPTION			AREA
R581	QRD125J-100	10	1/2W	UNF.CARBON	
R582	QRD125J-100	10	1/2W	UNF.CARBON	
R583	QRG022J-100A	10	2W	O.M.FILM	
R584	QRG022J-100A	10	2W	O.M.FILM	
R731	QRD14CJ-4R7S	4.7	1/4W	UNF.CARBON	
R732	QRD14CJ-4R7S	4.7	1/4W	UNF.CARBON	
R733	QRD167J-563	56K	1/6W	CARBON	
R734	QRD167J-472	4.7K	1/6W	CARBON	
R735	QRD167J-472	4.7K	1/6W	CARBON	
R736	QRD167J-103	10K	1/6W	CARBON	
R737	QRD167J-103	10K	1/6W	CARBON	
R738	QRD167J-122	1.2K	1/6W	CARBON	
R739	QRD14CJ-4R7S	4.7	1/4W	UNF.CARBON	
R740	QRD14CJ-4R7S	4.7	1/4W	UNF.CARBON	
R741	QRD167J-103	10K	1/6W	CARBON	
R742	QRX012J-2R2AM	2.2	1W	M.FILM	
R743	QRX012J-2R2AM	2.2	1W	M.FILM	
R744	QRD14CJ-4R7S	4.7	1/4W	UNF.CARBON	
R745	QRZ0077-100	10	1/4W	FUSIBLE	
R746	QRZ0077-100	10	1/4W	FUSIBLE	
R751	QRZ0077-100	10	1/4W	FUSIBLE	C
R752	QRZ0077-100	10	1/4W	FUSIBLE	C
R753	QRZ0077-100	10	1/4W	FUSIBLE	C
R754	QRZ0077-100	10	1/4W	FUSIBLE	C

OTHERS

ITEM	PART NUMBER	DESCRIPTION	AREA
	EWH69L-30LZ2	PARA WIRE	
	E03675-004	FUSE CLIP	A
	E03891-001	TAB	A
	E11378-202	CIRCUIT BOARD	
	E33754-001	TIE BAND	
	E70945-H25B	HEAT SINK	
	QMC0638-001	AC OUTLET	A
	SBSB3008CC	SCREW	
J501	EMBO0TP-801D	SPEAKER TERMINAL	
L501	EQL0003-1R0	INDUCTOR	
L502	EQL0003-1R0	INDUCTOR	
FC503	EMV7112-006R	CONNECTOR	
RT001	E67764-302	WRAPPING TERMINAL	A
RY501	ESK5024-214	RELAY	
RY502	ESK5024-214	RELAY	

△ : SAFETY PARTS

# ■ ENE-039 □ Front PC Board Ass'y

Note: ENE-039 □ varies according to the areas employed. See note (1) when placing an order.

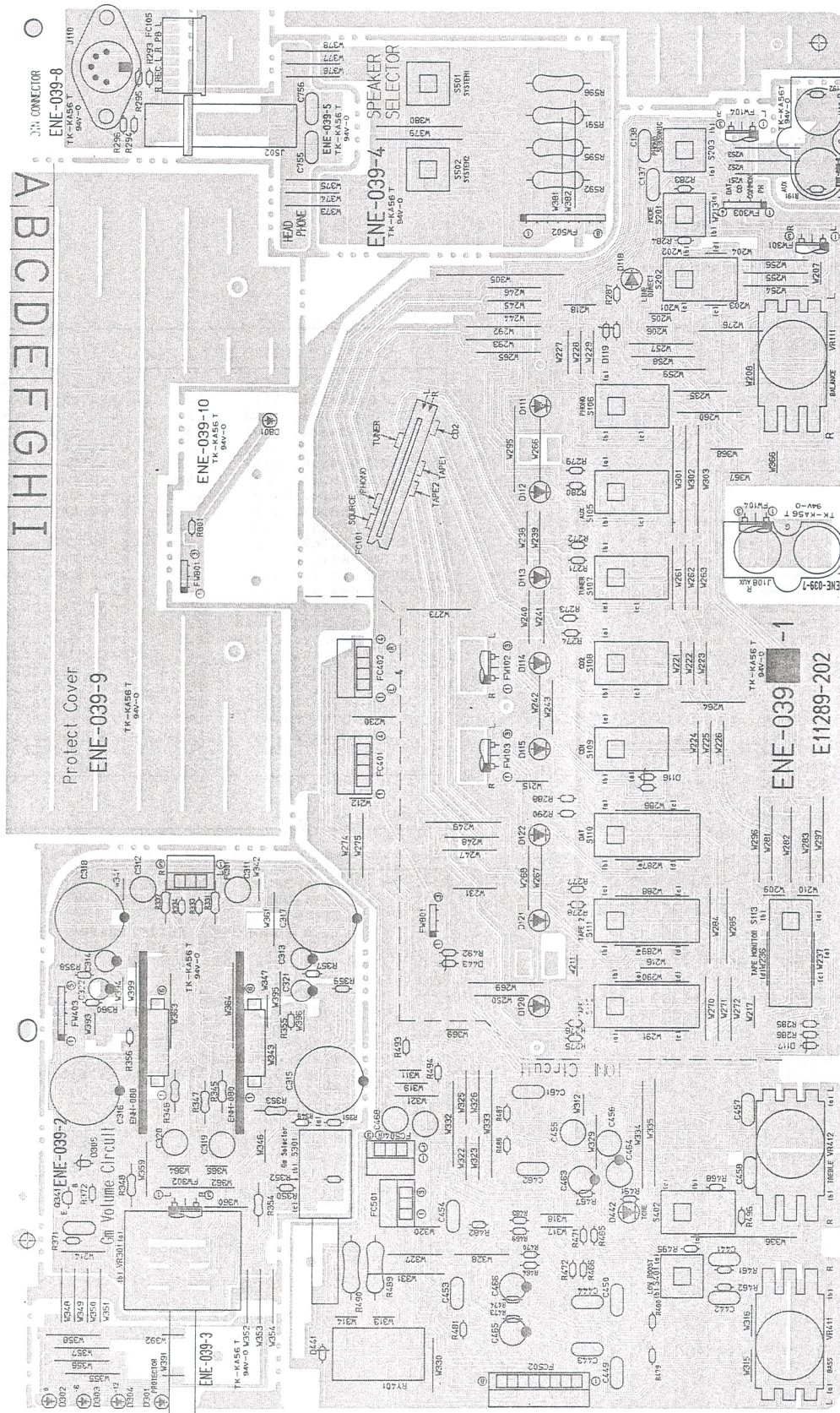

Note (1)

PC Board Ass'y	Designated Areas
ENE-039 <b>A</b>	U.S.A., Canada
ENE-039 <b>B</b>	Europe, Australia, U.K., U.S. Military Market & Other Countries
ENE-039 <b>C</b>	West Germany

TRANSISTORS

ITEM	PART NUMBER	DESCRIPTION		AREA
			MAKER	
Q341	2SA1015(Y)	SILICON	TOSHIBA	

DIODES

ITEM	PART NUMBER	DESCRIPTION		AREA
			MAKER	
D111	SLV-56DC50F165	L.E.D.		
D112	SLV-56DC50F165	L.E.D.		
D113	SLV-56DC50F165	L.E.D.		
D114	SLV-56DC50F165	L.E.D.		
D115	SLV-56DC50F165	L.E.D.		
D116	MTZ3.3JB	ZENER	ROHM	
D117	MTZ3.3JB	ZENER	ROHM	
D118	SLR-54DC50F165	L.E.D.	ROHM	
D119	MTZ3.3JB	ZENER	ROHM	
D120	SLV-56VC50F165	L.E.D.	ROHM	
D121	SLV-56VC50F165	L.E.D.	ROHM	
D122	SLV-56VC50F165	L.E.D.	ROHM	
D301	SLV-31VC3F	L.E.D.	ROHM	
D302	SLV-31DC3F	L.E.D.	ROHM	
D303	SLV-31DC3F	L.E.D.	ROHM	
D304	SLV-31DC3F	L.E.D.	ROHM	
D305	MTZ3.3JB	ZENER	ROHM	
D441	1S133	SILICON	ROHM	
D442	SLR-54DC50F165	L.E.D.	ROHM	
D443	MTZ3.3JB	ZENER	ROHM	
D801	SLV-31VC3F	L.E.D.	ROHM	

CAPACITORS

ITEM	PART NUMBER	DESCRIPTION		AREA
C137	QFV81HJ-154	0.15MF	50V T.FILM	
C138	QFV81HJ-154	0.15MF	50V T.FILM	
C311	QFS81HJ-101	100PF	50V POLYSTYROL	
C312	QFS81HJ-101	100PF	50V POLYSTYROL	
C313	QETB1HM-225	2.2MF	50V ELECTRO	
C314	QETB1HM-225	2.2MF	50V ELECTRO	
C315	EEN1002-475	4.7MF	100V NON POLE	
C316	EEN1002-475	4.7MF	100V NON POLE	
C317	QETB2AM-227H	220MF	100V ELECTRO	
C318	QETB2AM-227H	220MF	100V ELECTRO	
C319	QFS81HJ-101	100PF	50V POLYSTYROL	
C320	QFS81HJ-101	100PF	50V POLYSTYROL	
C321	QETB1HM-225	2.2MF	50V ELECTRO	
C322	QETB1HM-225	2.2MF	50V ELECTRO	
C441	QFV81HJ-473	0.047MF	50V T.FILM	
C442	QFV81HJ-473	0.047MF	50V T.FILM	
C443	QFN81HJ-153	0.015MF	50V MYLAR	
C444	QFN81HJ-153	0.015MF	50V MYLAR	
C449	QFV81HJ-823	0.082MF	50V T.FILM	
C450	QFV81HJ-823	0.082MF	50V T.FILM	
C453	QFN81HJ-332	3300PF	50V MYLAR	
C454	QFN81HJ-332	3300PF	50V MYLAR	
C455	QFS81HJ-221	220PF	50V POLYSTYROL	
C456	QFS81HJ-221	220PF	50V POLYSTYROL	
C457	QFN81HJ-102	1000PF	50V MYLAR	
C458	QFN81HJ-102	1000PF	50V MYLAR	
C461	QFN81HJ-183	0.018MF	50V MYLAR	
C462	QFN81HJ-183	0.018MF	50V MYLAR	
C463	QEN51HM-475	4.7MF	50V NON POLE	
C464	QEN51HM-475	4.7MF	50V NON POLE	
C465	QEN51HM-475	4.7MF	50V NON POLE	
C466	QEN51HM-475	4.7MF	50V NON POLE	
C467	QFS81HJ-7R0	7PF	50V POLYSTYROL	
C468	QFS81HJ-7R0	7PF	50V POLYSTYROL	
C755	QFN81HJ-222	2200PF	50V MYLAR	C
C756	QFN81HJ-222	2200PF	50V MYLAR	C

RESISTORS

ITEM	PART NUMBER	DESCRIPTION		AREA
R191	QRD167J-184	180K	1/6W CARBON	
R192	QRD167J-184	180K	1/6W CARBON	

RESISTORS

ITEM	PART NUMBER	DESCRIPTION		AREA
R271	QRD167J-331	330	1/6W CARBON	
R272	QRD167J-331	330	1/6W CARBON	
R273	QRD167J-331	330	1/6W CARBON	
R274	QRD167J-331	330	1/6W CARBON	
R275	QRD167J-331	330	1/6W CARBON	
R276	QRD167J-331	330	1/6W CARBON	
R277	QRD167J-331	330	1/6W CARBON	
R278	QRD167J-331	330	1/6W CARBON	
R279	QRD167J-331	330	1/6W CARBON	
R280	QRD167J-331	330	1/6W CARBON	
R283	QRD167J-472	4.7K	1/6W CARBON	
R284	QRD167J-472	4.7K	1/6W CARBON	
R285	QRD167J-101	100	1/6W CARBON	
R286	QRD167J-221	220	1/6W CARBON	
R287	QRD167J-101	100	1/6W CARBON	
R289	QRD167J-331	330	1/6W CARBON	
R290	QRD167J-331	330	1/6W CARBON	
R331	ERD141J-101S	100	1/4W CARBON	
R332	ERD141J-101S	100	1/4W CARBON	
R333	QRD167J-224	220K	1/6W CARBON	
R334	QRD167J-224	220K	1/6W CARBON	
R345	QRD167J-223	22K	1/6W CARBON	
R346	QRD167J-223	22K	1/6W CARBON	
R347	ERD141J-201S	200	1/4W CARBON	
R348	ERD141J-201S	200	1/4W CARBON	
R349	QRD167J-513	51K	1/6W CARBON	
R350	QRD167J-513	51K	1/6W CARBON	
R351	QRD167J-243	24K	1/6W CARBON	
R352	QRD167J-243	24K	1/6W CARBON	
R353	ERD141J-183S	18K	1/4W CARBON	
R354	ERD141J-183S	18K	1/4W CARBON	
R355	QRD167J-153	15K	1/6W CARBON	
R356	QRD167J-153	15K	1/6W CARBON	
R357	QRV144F-2203	220K	1/4W M.FILM	
R358	QRV144F-2203	220K	1/4W M.FILM	
R359	QRV144F-2203	220K	1/4W M.FILM	
R360	QRV144F-2203	220K	1/4W M.FILM	
R461	QRD167J-303	30K	1/6W CARBON	
R462	QRD167J-303	30K	1/6W CARBON	
R463	QRD167J-473	47K	1/6W CARBON	
R464	QRD167J-473	47K	1/6W CARBON	
R465	QRD167J-822	8.2K	1/6W CARBON	
R466	QRD167J-822	8.2K	1/6W CARBON	
R467	QRD167J-125	1.2M	1/6W CARBON	
R468	QRD167J-125	1.2M	1/6W CARBON	
R469	QRD167J-913	91K	1/6W CARBON	
R470	QRD167J-913	91K	1/6W CARBON	
R471	QRD167J-104	100K	1/6W CARBON	
R472	QRD167J-104	100K	1/6W CARBON	
R473	QRD167J-223	22K	1/6W CARBON	
R474	QRD167J-223	22K	1/6W CARBON	
R479	QRD167J-392	3.9K	1/6W CARBON	
R480	QRD167J-392	3.9K	1/6W CARBON	
R481	QRD167J-562	5.6K	1/6W CARBON	
R482	QRD167J-562	5.6K	1/6W CARBON	
R487	QRD167J-102	1K	1/6W CARBON	
R488	QRD167J-102	1K	1/6W CARBON	
R489	QRG022J-181A	180	2W O.M.FILM	
R490	QRG022J-102A	1K	2W O.M.FILM	
R491	QRD167J-101	100	1/6W CARBON	
R493	QRD167J-243	24K	1/6W CARBON	
R494	QRD167J-243	24K	1/6W CARBON	
R495	QRD167J-105	1M	1/6W CARBON	
R496	QRD167J-105	1M	1/6W CARBON	
R591	QRG022J-561A	560	2W O.M.FILM	
R592	QRG022J-561A	560	2W O.M.FILM	
R595	QRG022J-471A	470	2W O.M.FILM	
R596	QRG022J-471A	470	2W O.M.FILM	
R801	QRD167J-181	180	1/6W CARBON	
VR111	QVDB90M-EF5B	250K	VARIABLE	
VR301	QVFB93Z-E14B	10K	VARIABLE	
VR411	QVDB90Z-E15B	100K	VARIABLE	
VR412	QVDB90Z-E15B	100K	VARIABLE	

OTHERS

ITEM	PART NUMBER	DESCRIPTION		AREA
	E11289-202	CIRCUIT BOARD		
	E304344-001	LED HOLDER		
J109	EMN00YP-202A	2P PIN JACK		
J502	QMS6302-131	HEADPHONE JACK		
S105	QSTL842-E01	PUSH SWITCH		
S113	QSTL102-E01	PUSH SWITCH		
S201	QSTL341-E01	PUSH SWITCH		
S301	QSR6223-201	ROTARY SWITCH		
S401	QSTL241-E02	PUSH SWITCH		
S501	QSTL261-E01	PUSH SWITCH		
FC101	EMV7111-024	CONNECTOR		
FC301	EMV7112-003	CONNECTOR		
FC401	EMV7112-004	CONNECTOR		
FC402	EMV7112-004	CONNECTOR		
FC501	EMV7112-003	CONNECTOR		
FC502	EMV7112-008	CONNECTOR		
FC504	EMV7112-003	CONNECTOR		
RY401	ESK7D24-211	RELAY		

# ENE-037 Gm Equalizer PC Board Ass'y

Note: ENE-037 varies according to the areas employed. See note (1) when placing an order.

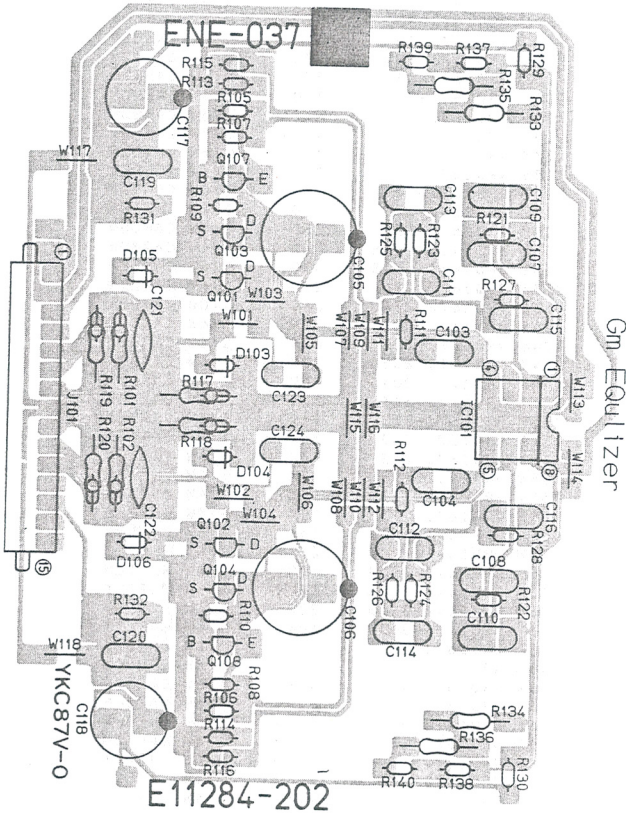

## DIODES

ITEM	PART NUMBER	DESCRIPTION	AREA	
			MAKER	
D103	1SS291	SILICON		
D104	1SS291	SILICON		
D105	1SS291	SILICON		
D106	1SS291	SILICON		

## CAPACITORS

ITEM	PART NUMBER	DESCRIPTION	AREA	
			MAKER	
C103	QFN81HJ-562	5600PF 50V	MYLAR	
C104	QFN81HJ-562	5600PF 50V	MYLAR	
C105	QETBOJM-228	2200MF 6.3V	ELECTRO	
C106	QETBOJM-228	2200MF 6.3V	ELECTRO	
C107	QFP81HJ-470	47PF 50V	POLY	
C108	QFP81HJ-470	47PF 50V	POLY	
C109	QFP81HJ-221	220PF 50V	POLY	
C110	QFP81HJ-221	220PF 50V	POLY	
C111	QFP81HG-682	6800PF 50V	POLY	
C112	QFP81HG-682	6800PF 50V	POLY	
C113	QFP81HG-103	0.01MF 50V	POLY	
C114	QFP81HG-103	0.01MF 50V	POLY	
C115	QFP81HG-472	4700PF 50V	POLY	
C116	QFP81HG-472	4700PF 50V	POLY	
C117	QETB2AM-106H	10MF 100V	ELECTRO	
C118	QETB2AM-106H	10MF 100V	ELECTRO	
C119	QFP81HJ-222	2200PF 50V	POLY	B
C120	QFP81HJ-222	2200PF 50V	POLY	B
C123	QFP81HJ-680	68PF 50V	POLY	
C124	QFP81HJ-680	68PF 50V	POLY	

## RESISTORS

ITEM	PART NUMBER	DESCRIPTION	AREA	
			MAKER	
R101	QRD167J-5R6	5.6 1/6W	CARBON	
R102	QRD167J-5R6	5.6 1/6W	CARBON	
R105	QRD167J-222	2.2K 1/6W	CARBON	
R106	QRD167J-222	2.2K 1/6W	CARBON	
R107	QRD167J-242	2.4K 1/6W	CARBON	
R108	QRD167J-242	2.4K 1/6W	CARBON	
R109	QRD167J-272	2.7K 1/6W	CARBON	
R110	QRD167J-272	2.7K 1/6W	CARBON	
R111	QRD167J-470	47 1/6W	CARBON	
R112	QRD167J-470	47 1/6W	CARBON	
R113	QRD167J-222	2.2K 1/6W	CARBON	
R114	QRD167J-222	2.2K 1/6W	CARBON	
R115	QRD167J-182	1.8K 1/6W	CARBON	
R116	QRD167J-182	1.8K 1/6W	CARBON	
R117	ERD141J-220S	22 1/4W	CARBON	
R118	ERD141J-220S	22 1/4W	CARBON	
R119	ERD141J-271S	270 1/4W	CARBON	
R120	ERD141J-271S	270 1/4W	CARBON	
R121	QRD167J-125	1.2M 1/6W	CARBON	
R122	QRD167J-125	1.2M 1/6W	CARBON	
R123	QRV144F-1002	10K 1/4W	M. FILM	
R124	QRV144F-1002	10K 1/4W	M. FILM	
R125	QRV144F-1803	180K 1/4W	M. FILM	
R126	QRV144F-1803	180K 1/4W	M. FILM	
R127	QRV144F-1602	16K 1/4W	M. FILM	
R128	QRV144F-1602	16K 1/4W	M. FILM	
R129	QRD167J-101	100 1/6W	CARBON	
R130	QRD167J-101	100 1/6W	CARBON	
R131	QRD167J-104	100K 1/6W	CARBON	
R132	QRD167J-104	100K 1/6W	CARBON	
R133	QRD148J-475S	4.7M 1/4W	CARBON	
R134	QRD148J-475S	4.7M 1/4W	CARBON	
R135	QRD148J-475S	4.7M 1/4W	CARBON	
R136	QRD148J-475S	4.7M 1/4W	CARBON	
R137	QRD167J-155	1.5M 1/6W	CARBON	
R138	QRD167J-155	1.5M 1/6W	CARBON	
R139	QRD167J-125	1.2M 1/6W	CARBON	
R140	QRD167J-125	1.2M 1/6W	CARBON	

Note (1)

PC Board Ass'y	Dsignated Areas
ENE-037 A	U.S.A., Canada Europe, Australia, U.K., U.S. Military Market & Other Countries
ENE-037 B	West Germany

## TRANSISTORS

ITEM	PART NUMBER	DESCRIPTION	AREA	
			MAKER	
Q101	2SK170(GR,BL)	F.E.T		
Q102	2SK170(GR,BL)	F.E.T		
Q103	2SK170(GR,BL)	F.E.T		
Q104	2SK170(GR,BL)	F.E.T		
Q107	2SA970(GR,BL)	SILICON	TOSHIBA	
Q108	2SA970(GR,BL)	SILICON	TOSHIBA	

## I. C. S

ITEM	PART NUMBER	DESCRIPTION	AREA	
			MAKER	
IC101	NJM4560D-X	I.C.		

## OTHERS

ITEM	PART NUMBER	DESCRIPTION	AREA
J101	E11284-202 EMV5112-015R	CIRCUIT BOARD PLUG ASSY	

△ : SAFETY PARTS

# ■ ENE-038 □ Differential PC Board Ass'y

Note: ENE-038 □ varies according to the areas employed. See note (1) when placing an order.

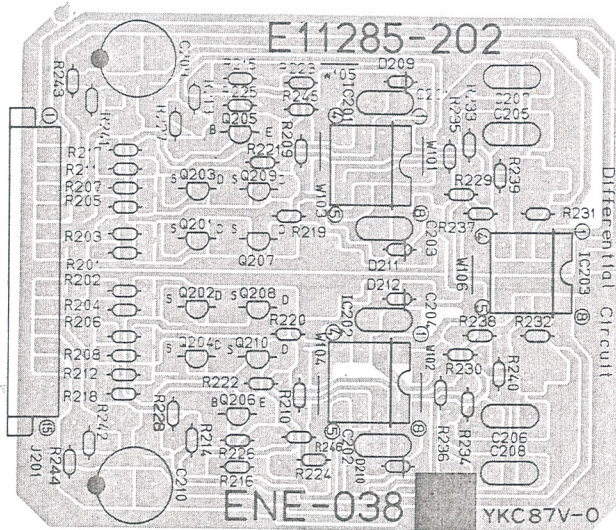

Note (1)

PC Board Ass'y	Designated Areas
ENE-038 <b>A</b>	U.S.A., Canada Europe, Australia, U.K., U.S. Military Market & Other Countries
ENE-038 <b>B</b>	West Germany

## TRANSISTORS

ITEM	PART NUMBER	DESCRIPTION	AREA	
			MAKER	
Q201	2SK170(GR,BL)	F.E.T		
Q202	2SK170(GR,BL)	F.E.T		
Q203	2SK170(GR,BL)	F.E.T		
Q204	2SK170(GR,BL)	F.E.T		
Q205	2SC2240(GR,BL)	SILICON	TOSHIBA	
Q206	2SC2240(GR,BL)	SILICON	TOSHIBA	
Q207	2SK246(BL,V)	F.E.T	TOSHIBA	
Q208	2SK246(BL,V)	F.E.T	TOSHIBA	
Q209	2SK246(BL,V)	F.E.T	TOSHIBA	
Q210	2SK246(BL,V)	F.E.T	TOSHIBA	

## I. C. S

ITEM	PART NUMBER	DESCRIPTION	AREA	
			MAKER	
IC201	M5219P	I.C.	mitsubishi	
IC202	M5219P	I.C.	mitsubishi	
IC203	NJM5532DD	I.C.		

## DIODES

ITEM	PART NUMBER	DESCRIPTION	AREA	
			MAKER	
D209	1SS147	SILICON	ROHM	
D210	1SS147	SILICON	ROHM	
D211	1SS147	SILICON	ROHM	
D212	1SS147	SILICON	ROHM	

## CAPACITORS

ITEM	PART NUMBER	DESCRIPTION			AREA
C201	QFS81HJ-220	22PF	50V	POLYSTYROL	
C202	QFS81HJ-220	22PF	50V	POLYSTYROL	
C203	QFS81HJ-220	22PF	50V	POLYSTYROL	
C204	QFS81HJ-220	22PF	50V	POLYSTYROL	
C205	QFS81HJ-121	120PF	50V	POLYSTYROL	
C206	QFS81HJ-121	120PF	50V	POLYSTYROL	
C207	QFS81HJ-121	120PF	50V	POLYSTYROL	
C208	QFS81HJ-121	120PF	50V	POLYSTYROL	
C209	QETB2AM-106H	10MF	100V	ELECTRO	
C210	QETB2AM-106H	10MF	100V	ELECTRO	
C211	QFP81HJ-221	220PF	50V	POLY	B
C212	QFP81HJ-221	220PF	50V	POLY	B
C213	QFP81HJ-222	2200PF	50V	POLY	B
C214	QFP81HJ-222	2200PF	50V	POLY	B

## RESISTORS

ITEM	PART NUMBER	DESCRIPTION			AREA
R201	QRD167J-221	220	1/6W	CARBON	
R202	QRD167J-221	220	1/6W	CARBON	
R203	QRD167J-224	220K	1/6W	CARBON	
R204	QRD167J-224	220K	1/6W	CARBON	
R205	QRD167J-221	220	1/6W	CARBON	
R206	QRD167J-221	220	1/6W	CARBON	
R207	QRD167J-224	220K	1/6W	CARBON	
R208	QRD167J-224	220K	1/6W	CARBON	
R209	QRD167J-272	2.7K	1/6W	CARBON	
R210	QRD167J-272	2.7K	1/6W	CARBON	
R211	QRD167J-511	510	1/6W	CARBON	
R212	QRD167J-511	510	1/6W	CARBON	
R213	QRD167J-122	1.2K	1/6W	CARBON	
R214	QRD167J-122	1.2K	1/6W	CARBON	
R215	QRD167J-272	2.7K	1/6W	CARBON	
R216	QRD167J-272	2.7K	1/6W	CARBON	
R217	QRD167J-511	510	1/6W	CARBON	
R218	QRD167J-511	510	1/6W	CARBON	
R219	QRD167J-302	3K	1/6W	CARBON	
R220	QRD167J-302	3K	1/6W	CARBON	
R221	QRD167J-302	3K	1/6W	CARBON	
R222	QRD167J-302	3K	1/6W	CARBON	
R223	QRD167J-332	3.3K	1/6W	CARBON	
R224	QRD167J-332	3.3K	1/6W	CARBON	
R225	QRD167J-912	9.1K	1/6W	CARBON	
R226	QRD167J-912	9.1K	1/6W	CARBON	
R227	QRD167J-332	3.3K	1/6W	CARBON	
R228	QRD167J-332	3.3K	1/6W	CARBON	
R229	QRD167J-472	4.7K	1/6W	CARBON	
R230	QRD167J-472	4.7K	1/6W	CARBON	
R231	QRD167J-681	680	1/6W	CARBON	
R232	QRD167J-681	680	1/6W	CARBON	
R233	QRD167J-101	100	1/6W	CARBON	
R234	QRD167J-101	100	1/6W	CARBON	
R235	QRD167J-101	100	1/6W	CARBON	
R236	QRD167J-101	100	1/6W	CARBON	
R237	QRD167J-472	4.7K	1/6W	CARBON	
R238	QRD167J-472	4.7K	1/6W	CARBON	
R239	QRD167J-681	680	1/6W	CARBON	
R240	QRD167J-681	680	1/6W	CARBON	
R241	QRD167J-124	120K	1/6W	CARBON	
R242	QRD167J-124	120K	1/6W	CARBON	
R243	QRD167J-101	100	1/6W	CARBON	
R244	QRD167J-101	100	1/6W	CARBON	
R245	QRD167J-912	9.1K	1/6W	CARBON	
R246	QRD167J-912	9.1K	1/6W	CARBON	

## OTHERS

ITEM	PART NUMBER	DESCRIPTION			AREA
J201	E11285-202 EMV5112-015R	CIRCUIT BOARD PLUG ASSY			

△ : SAFETY PARTS



# ■ ENH-095 A Gm Driver PC Board Ass'y

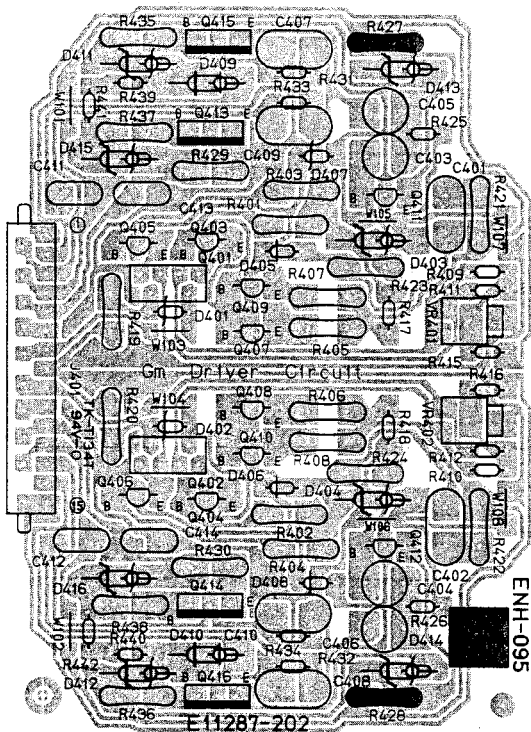

## CAPACITORS

△	ITEM	PART NUMBER	DESCRIPTION	AREA
	C401	QFP81HJ-222	2200PF 50V POLY	
	C402	QFP81HJ-222	2200PF 50V POLY	
	C403	QFS82BJ-390	39PF 125V POLYSTYROL	
	C404	QFS82BJ-390	39PF 125V POLYSTYROL	
	C405	QFS82BJ-680	68PF 125V POLYSTYROL	
	C406	QFS82BJ-680	68PF 125V POLYSTYROL	
	C407	QFN81HJ-222	2200PF 50V MYLAR	
	C408	QFN81HJ-222	2200PF 50V MYLAR	
	C409	QFN81HJ-222	2200PF 50V MYLAR	
	C410	QFN81HJ-222	2200PF 50V MYLAR	

## RESISTORS

△	ITEM	PART NUMBER	DESCRIPTION	AREA
△	R401	QRZ0077-561	560 1/4W FUSIBLE	
△	R402	QRZ0077-561	560 1/4W FUSIBLE	
△	R403	QRZ0077-561	560 1/4W FUSIBLE	
△	R404	QRZ0077-561	560 1/4W FUSIBLE	
△	R405	QRD14CJ-331S	330 1/4W UNF. CARBON	
△	R406	QRD14CJ-331S	330 1/4W UNF. CARBON	
△	R407	QRD14CJ-331S	330 1/4W UNF. CARBON	
△	R408	QRD14CJ-331S	330 1/4W UNF. CARBON	
	R409	QRD167J-220	22 1/6W CARBON	
	R410	QRD167J-220	22 1/6W CARBON	
	R411	QRD167J-220	22 1/6W CARBON	
	R412	QRD167J-220	22 1/6W CARBON	
	R415	QRD167J-752	7.5K 1/6W CARBON	
	R416	QRD167J-752	7.5K 1/6W CARBON	
	R417	QRD167J-473	47K 1/6W CARBON	
	R418	QRD167J-473	47K 1/6W CARBON	
△	R419	QRZ0077-331	330 1/4W FUSIBLE	
△	R420	QRZ0077-331	330 1/4W FUSIBLE	
△	R421	QRD14CJ-271S	270 1/4W UNF. CARBON	
△	R422	QRD14CJ-271S	270 1/4W UNF. CARBON	
△	R423	QRZ0077-102	1K 1/4W FUSIBLE	
△	R424	QRZ0077-102	1K 1/4W FUSIBLE	
	R425	QRD167J-332	3.3K 1/6W CARBON	
	R426	QRD167J-332	3.3K 1/6W CARBON	
△	R427	QRZ0077-680	68 1/4W FUSIBLE	
△	R428	QRZ0077-680	68 1/4W FUSIBLE	
△	R429	QRD14CJ-151S	150 1/4W UNF. CARBON	
△	R430	QRD14CJ-151S	150 1/4W UNF. CARBON	
	R431	QRD167J-562	5.6K 1/6W CARBON	
	R432	QRD167J-562	5.6K 1/6W CARBON	
	R433	QRD167J-562	5.6K 1/6W CARBON	
	R434	QRD167J-562	5.6K 1/6W CARBON	
△	R435	QRD14CJ-821S	820 1/4W UNF. CARBON	
△	R436	QRD14CJ-821S	820 1/4W UNF. CARBON	
△	R437	QRD14CJ-101S	100 1/4W UNF. CARBON	
△	R438	QRD14CJ-101S	100 1/4W UNF. CARBON	
	R439	QRD167J-563	56K 1/6W CARBON	
	R440	QRD167J-563	56K 1/6W CARBON	
	R441	QRD167J-563	56K 1/6W CARBON	
	R442	QRD167J-563	56K 1/6W CARBON	
	VR401	GVPC603-101	100 0.3W VARIABLE	
	VR402	GVPC603-101	100 0.3W VARIABLE	

△ : SAFETY PARTS

## TRANSISTORS

△	ITEM	PART NUMBER	DESCRIPTION	AREA	
				MAKER	
	Q401	2SK389NK(BL,V)	F.E.T	TOSHIBA	
	Q402	2SK389NK(BL,V)	F.E.T	TOSHIBA	
	Q403	2SC2240(GR,BL)	SILICON	TOSHIBA	
	Q404	2SC2240(GR,BL)	SILICON	TOSHIBA	
	Q405	2SC2240(GR,BL)	SILICON	TOSHIBA	
	Q406	2SC2240(GR,BL)	SILICON	TOSHIBA	
	Q407	2SA1029(C,D)	SILICON	HITACHI	
	Q408	2SA1029(C,D)	SILICON	HITACHI	
	Q409	2SA1029(C,D)	SILICON	HITACHI	
	Q410	2SA1029(C,D)	SILICON	HITACHI	
	Q411	2SA1029(C,D)	SILICON	HITACHI	
	Q412	2SA1029(C,D)	SILICON	HITACHI	
	Q413	2SC2912(S,T)	SILICON	SANYO	
	Q414	2SC2912(S,T)	SILICON	SANYO	
	Q415	2SA1210(S,T)	SILICON	SANYO	
	Q416	2SA1210(S,T)	SILICON	SANYO	

## DIODES

△	ITEM	PART NUMBER	DESCRIPTION	AREA	
				MAKER	
	D401	1SS133	SILICON	ROHM	
	D402	1SS133	SILICON	ROHM	
	D403	MTZ5.6JC	ZENER	ROHM	
	D404	MTZ5.6JC	ZENER	ROHM	
	D405	1SS133	SILICON	ROHM	
	D406	1SS133	SILICON	ROHM	
	D407	1SS133	SILICON	ROHM	
	D408	1SS133	SILICON	ROHM	
	D409	1SS81	SILICON	HITACHI	
	D410	1SS81	SILICON	HITACHI	
	D411	RD2.7EB2	ZENER	NEC	
	D412	RD2.7EB2	ZENER	NEC	
	D413	RD2.7EB2	ZENER	NEC	
	D414	RD2.7EB2	ZENER	NEC	
	D415	RD2.7EB2	ZENER	NEC	
	D416	RD2.7EB2	ZENER	NEC	

# ENH-095 A Gm Driver PC Board Ass'y

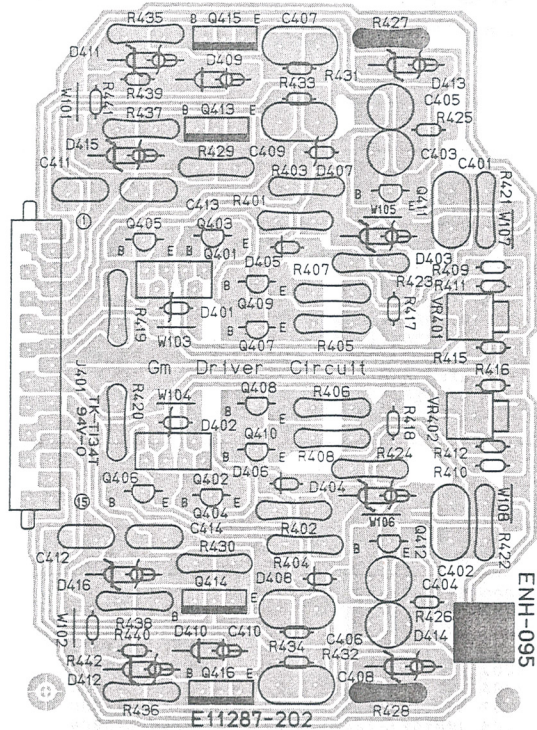

## CAPACITORS

ITEM	PART NUMBER	DESCRIPTION	AREA
C401	QFP81HJ-222	2200PF 50V POLY	
C402	QFP81HJ-222	2200PF 50V POLY	
C403	QFS82BJ-390	39PF 125V POLYSTYROL	
C404	QFS82BJ-390	39PF 125V POLYSTYROL	
C405	QFS82BJ-680	68PF 125V POLYSTYROL	
C406	QFS82BJ-680	68PF 125V POLYSTYROL	
C407	QFN81HJ-222	2200PF 50V MYLAR	
C408	QFN81HJ-222	2200PF 50V MYLAR	
C409	QFN81HJ-222	2200PF 50V MYLAR	
C410	QFN81HJ-222	2200PF 50V MYLAR	

## RESISTORS

ITEM	PART NUMBER	DESCRIPTION	AREA
R401	QRZ0077-561	560 1/4W FUSIBLE	
R402	QRZ0077-561	560 1/4W FUSIBLE	
R403	QRZ0077-561	560 1/4W FUSIBLE	
R404	QRZ0077-561	560 1/4W FUSIBLE	
R405	QRD14CJ-331S	330 1/4W UNF. CARBON	
R406	QRD14CJ-331S	330 1/4W UNF. CARBON	
R407	QRD14CJ-331S	330 1/4W UNF. CARBON	
R408	QRD14CJ-331S	330 1/4W UNF. CARBON	
R409	QRD167J-220	22 1/6W CARBON	
R410	QRD167J-220	22 1/6W CARBON	
R411	QRD167J-220	22 1/6W CARBON	
R412	QRD167J-220	22 1/6W CARBON	
R415	QRD167J-752	7.5K 1/6W CARBON	
R416	QRD167J-752	7.5K 1/6W CARBON	
R417	QRD167J-473	47K 1/6W CARBON	
R418	QRD167J-473	47K 1/6W CARBON	
R419	QRZ0077-331	330 1/4W FUSIBLE	
R420	QRZ0077-331	330 1/4W FUSIBLE	
R421	QRD14CJ-271S	270 1/4W UNF. CARBON	
R422	QRD14CJ-271S	270 1/4W UNF. CARBON	
R423	QRZ0077-102	1K 1/4W FUSIBLE	
R424	QRZ0077-102	1K 1/4W FUSIBLE	
R425	QRD167J-332	3.3K 1/6W CARBON	
R426	QRD167J-332	3.3K 1/6W CARBON	
R427	QRZ0077-680	68 1/4W FUSIBLE	
R428	QRZ0077-680	68 1/4W FUSIBLE	
R429	QRD14CJ-151S	150 1/4W UNF. CARBON	
R430	QRD14CJ-151S	150 1/4W UNF. CARBON	
R431	QRD167J-562	5.6K 1/6W CARBON	
R432	QRD167J-562	5.6K 1/6W CARBON	
R433	QRD167J-562	5.6K 1/6W CARBON	
R434	QRD167J-562	5.6K 1/6W CARBON	
R435	QRD14CJ-821S	820 1/4W UNF. CARBON	
R436	QRD14CJ-821S	820 1/4W UNF. CARBON	
R437	QRD14CJ-101S	100 1/4W UNF. CARBON	
R438	QRD14CJ-101S	100 1/4W UNF. CARBON	
R439	QRD167J-563	56K 1/6W CARBON	
R440	QRD167J-563	56K 1/6W CARBON	
R441	QRD167J-563	56K 1/6W CARBON	
R442	QRD167J-563	56K 1/6W CARBON	
VR401	GVPC603-101	100 0.3W VARIABLE	
VR402	GVPC603-101	100 0.3W VARIABLE	

△ : SAFETY PARTS

## TRANSISTORS

ITEM	PART NUMBER	DESCRIPTION	MAKER	AREA
Q401	2SK389NK(BL,V)	F.E.T	TOSHIBA	
Q402	2SK389NK(BL,V)	F.E.T	TOSHIBA	
Q403	2SC2240(GR,BL)	SILICON	TOSHIBA	
Q404	2SC2240(GR,BL)	SILICON	TOSHIBA	
Q405	2SC2240(GR,BL)	SILICON	TOSHIBA	
Q406	2SC2240(GR,BL)	SILICON	TOSHIBA	
Q407	2SA1029(C,D)	SILICON	HITACHI	
Q408	2SA1029(C,D)	SILICON	HITACHI	
Q409	2SA1029(C,D)	SILICON	HITACHI	
Q410	2SA1029(C,D)	SILICON	HITACHI	
Q411	2SA1029(C,D)	SILICON	HITACHI	
Q412	2SA1029(C,D)	SILICON	HITACHI	
Q413	2SC2912(S,T)	SILICON	SANYO	
Q414	2SC2912(S,T)	SILICON	SANYO	
Q415	2SA1210(S,T)	SILICON	SANYO	
Q416	2SA1210(S,T)	SILICON	SANYO	

## DIODES

ITEM	PART NUMBER	DESCRIPTION	MAKER	AREA
D401	1SS133	SILICON	ROHM	
D402	1SS133	SILICON	ROHM	
D403	MTZ5.6JC	ZENER	ROHM	
D404	MTZ5.6JC	ZENER	ROHM	
D405	1SS133	SILICON	ROHM	
D406	1SS133	SILICON	ROHM	
D407	1SS133	SILICON	ROHM	
D408	1SS133	SILICON	ROHM	
D409	1SS81	SILICON	HITACHI	
D410	1SS81	SILICON	HITACHI	
D411	RD2.7EB2	ZENER	NEC	
D412	RD2.7EB2	ZENER	NEC	
D413	RD2.7EB2	ZENER	NEC	
D414	RD2.7EB2	ZENER	NEC	
D415	RD2.7EB2	ZENER	NEC	
D416	RD2.7EB2	ZENER	NEC	

# ■ ENH-071 D Power Supply Switching PC Board Ass'y

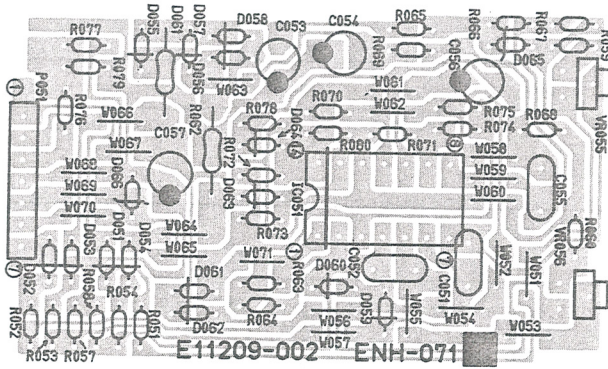

I. C. S

ITEM	PART NUMBER	DESCRIPTION	AREA	
				MAKER
IC051	AN6912	I.C.		MATSUSHITA

DIODES

ITEM	PART NUMBER	DESCRIPTION	AREA	
				MAKER
D051	1SS133	SILICON	ROHM	
D052	1SS133	SILICON	ROHM	
D053	1SS133	SILICON	ROHM	
D054	1SS133	SILICON	ROHM	
D055	1SS147	SILICON	ROHM	
D056	1SS147	SILICON	ROHM	
D057	1SS147	SILICON	ROHM	
D058	1SS147	SILICON	ROHM	
D059	1SS133	SILICON	ROHM	
D060	1SS133	SILICON	ROHM	
D061	1SS133	SILICON	ROHM	
D062	1SS133	SILICON	ROHM	
D063	1SS133	SILICON	ROHM	
D064	1SS133	SILICON	ROHM	
D065	MTZ11JC	ZENER	ROHM	

CAPACITORS

ITEM	PART NUMBER	DESCRIPTION			AREA
C051	QFN81HJ-102	1000PF	50V	MYLAR	
C052	QFN81HJ-102	1000PF	50V	MYLAR	
C053	QETB2AM-105	1MF	100V	ELECTRO	
C054	QETB2AM-225	2.2MF	100V	ELECTRO	
C055	QFN81HJ-103	0.01MF	50V	MYLAR	
C056	QETB1EM-476	47MF	25V	ELECTRO	
C057	QETB1HM-225	2.2MF	50V	ELECTRO	

RESISTORS

ITEM	PART NUMBER	DESCRIPTION			AREA
R051	QRD167J-473	47K	1/6W	CARBON	
R052	QRD167J-473	47K	1/6W	CARBON	
R053	QRD167J-473	47K	1/6W	CARBON	
R054	QRD167J-473	47K	1/6W	CARBON	
R057	QRD167J-153	15K	1/6W	CARBON	
R058	QRD167J-153	15K	1/6W	CARBON	
R059	QRD167J-123	12K	1/6W	CARBON	
R060	QRD167J-123	12K	1/6W	CARBON	
R061	QRD145J-101S	100	1/4W	UNF. CARBON	
R062	QRD145J-101S	100	1/4W	UNF. CARBON	
R063	QRD167J-153	15K	1/6W	CARBON	
R064	QRD167J-153	15K	1/6W	CARBON	
R065	QRD167J-223	22K	1/6W	CARBON	
R066	QRD167J-563	56K	1/6W	CARBON	
R067	QRD167J-473	47K	1/6W	CARBON	
R068	QRD167J-153	15K	1/6W	CARBON	
R069	QRD167J-823	82K	1/6W	CARBON	
R070	QRD167J-271	270	1/6W	CARBON	
R071	QRD167J-914	910K	1/6W	CARBON	
R072	QRD167J-472	4.7K	1/6W	CARBON	
R073	QRD167J-472	4.7K	1/6W	CARBON	
R074	QRD167J-154	150K	1/6W	CARBON	
R075	QRD167J-472	4.7K	1/6W	CARBON	
R076	QRD167J-103	10K	1/6W	CARBON	
R077	QRD167J-224	220K	1/6W	CARBON	
R078	QRD167J-474	470K	1/6W	CARBON	
R079	QRD167J-474	470K	1/6W	CARBON	
R080	QRD167J-914	910K	1/6W	CARBON	
VR055	QVPC603-472	4.7K	0.3W	VARIABLE	
VR056	QVPC603-472	4.7K	0.3W	VARIABLE	D

OTHERS

ITEM	PART NUMBER	DESCRIPTION	AREA
P051	E11209-002	CIRCUIT BOARD	
	EMV5101-007B	PLUG ASSY	

# ■ TPS-318 C Voltage Selector PC Board Ass'y

(Except for U.S.A., Canada, U.K., Europe, West Germany, Australia)

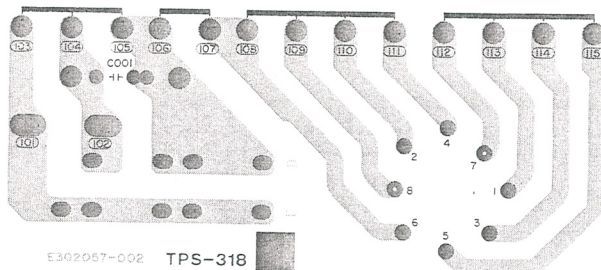

CAPACITORS

ITEM	PART NUMBER	DESCRIPTION	AREA
C001	QCZ9038-103	0.01MF	CERAMIC

OTHERS

ITEM	PART NUMBER	DESCRIPTION	AREA
	E302057-002	CIRCUIT BOARD	
	E65508-002	TAB	
	E67764-302	WRAPPING TERMINAL	
	E67764-303	WRAPPING TERMINAL	
	E67764-304	WRAPPING TERMINAL	
	QMC0637-004	AC OUTLET	
	QSR0085-008U	VOLTAGE SELECTOR	

△ : SAFETY PARTS

# ■ END-040 □ Primary PC Board Ass'y

(For Europe, Australia, West Germany, U.K.)

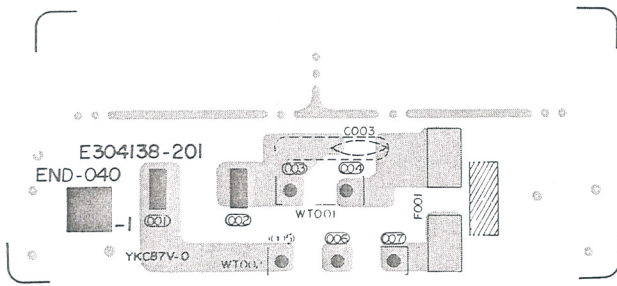

Note (1)

PC Board Ass'y	Designated Areas
END-040 <span style="border: 1px solid black; padding: 0 2px;">A</span>	Europe, Australia, West Germany
END-040 <span style="border: 1px solid black; padding: 0 2px;">B</span> BS	U.K.

## CAPACITORS

ITEM	PART NUMBER	DESCRIPTION	AREA
△ C003	QCZ9019-472	4700PF	A
△ C003	QCZ9019-472BS	4700PF	BBS

## OTHERS

ITEM	PART NUMBER	DESCRIPTION	AREA
	EMG7331-001	FUSE CLIP	
	E304138-201	CIRCUIT BOARD	A
	E65508-002	TAB	
	E67132-T4R0	T4R0 FUSE LABEL	
WTC01	E67764-202	WRAPPING TERMINAL	
WTC02	E67764-203	WRAPPING TERMINAL	
	E304138-201BS	CIRCUIT BOARD	BBS

△ : SAFETY PARTS

## Accessories List

△	Part Number	Part Name	Q'ty	Description	Areas
	E30580-1408A	Instruction Book	1		Except BS
	E30580-1408ABS	Instruction Book	1		BS
	BT20044E	Safety Instruction Sheet	1		J
	BT20071A	Service Centre List	1		C
	BT20025A	Warranty Card	1		C
	BT20029C	Warranty Card	1	for Australia	A
	BT20098	Warranty Card	1	for New Zealand	A
	BT20046C	Service Information Card	1		J, P, PG
	BT20048C	Warranty Card	1		J, P, PG
	BT20060	Warranty Card	1		BS
	BT20066	EEC Agency	1		G, BS
	BT20064	Warranty Card	1		G
	QZL1008-001	FTZ Information Sheet	1		G
△	E04056	Siemens Plug	1		PG, U
△	QMF51A2-4ROS	Fuse	1		P
△	QMF51A2-8ROL	Fuse	1		PG, U
	E67142-T4R0	Fuse Label	1		P
	E67142-T8R0	Fuse Label	1		PG, U
	EWP201-008	GND Wire	1		
	E43486-296A	Sheet	1		Except BS
	E43486-296ABS	Sheet	1		BS
	E72360-001	Caution Sheet	1		C
	QPGBO10-02003	Envelope	1		J
	E66416-003	Envelope	1		P, PG, U
	E6581-4	Envelope	1	for Fuse & Fuse Label	
	E41202-2	Envelope	1	for Instruction Book	Except BS
	E41202-2B	Envelope	1	for Instruction Book	BS

△: Safety Parts

### The Marks for Designated Areas

J..... U.S.A                      G..... West Germany  
 C..... Canada                      BS..... U.K.  
 E..... Europe                      P, PG..... U.S. Military Market  
 A..... Australia                      U..... Other Countries  
 No mark indicates all area.

# Packing Materials and Part Numbers

