

INSTRUCTION BOOK
H·H·SCOTT

LEADER IN AUDIO ENGINEERING AND DESIGN

Model LM-35

H. H. Scott

world leader in amplifiers, tuners, speakers and kits

H. H. Scott has been a leading manufacturer of superb high fidelity components since 1946. During this period Scott has been responsible for the introduction of many new concepts in both the engineering and design of components. H. H. Scott produced the first high fidelity amplifier (in the modern sense of the term). Later, Scott eliminated unsightly wires and tubes by designing the first "flat" amplifier . . . bringing high fidelity components from the workshop to the livingroom. Scott was the first manufacturer to introduce a successful Wide-Band FM tuner. Scott was first to deliver multiplex adaptors that met the requirements of the FCC approved transmission system. Scott was the first to produce modular tuner-amplifier combinations.

For many years, Scott engineers were investigating the idea of introducing Scott components in kit form for the home builder. However, they felt that the kits then on the market were too uncertain in the hands of amateur kit

builders. The wiring diagrams were extremely complex. Alignment and balancing required special test equipment. Kits looked like kits . . . they were unattractive and bulky.

Scott engineers decided to take a brand new approach. First of all, new components were developed that were foolproof for home builders. Circuitry was devised to make placement of wires and parts less critical. A unique system of FM tuner alignment (called the Ez-A-Line method) eliminated the need for special test instruments.

Instruction books were written so that they avoided the pitfalls common to other kits. They were in full color. Only a limited number of steps were described per page, and special Part-Charts were created to hold the parts described on each page separately, and in the order used. The kit builder need know nothing about engineering to successfully build Scottkits.

Results have been spectacular. Amateurs who never even soldered before report that they have built Scottkits that beat our published specifications in just a few hours. Magazine editors and reviewers tell us our specifications are much too conservative. Other manufacturers are paying us the highest compliment of emulating our designs and original features.

There is one thing, however, that cannot be copied. The Scott reputation for quality, integrity and leadership . . . a reputation hard-won by consistent attention to detail . . . by continual advance in engineering . . . by imaginative innovation . . . by a philosophy that states "purchase by the customer marks a beginning . . . not the end." Our best salesmen are unpaid — our satisfied customers.

Hermon Hosmer Scott . . . Audio Pioneer

"Hermon Hosmer Scott is a soft-spoken man, with a down-East accent to which he is entitled . . . We have been gratefully aware of him since 1947. He is the man who took the grit out of Grieg and the scratch out of Scriabin by inventing the Dynaural Noise Suppressor. If you use an H.H.S./D.N.S. a 78 sounds as clean as an LP, and an LP sounds as clean as live FM.

"Scott has received many engineering citations, some for truly basic work in electronic measurement . . . yet he is honored and heeded most by his friends on the grounds of ethics and esthetics. This . . . is reflected in the clear reliability of his products.

"Scott . . . is terribly irritated by imperfections of any kind. He does not see why an amplifier or a tone arm should be ugly any more than a 'cello is. To this we owe a revolution since it was Scott who in 1953 gave us the Model 99 amplifier which did not need to be hidden . . . Everyone now follows this precedent, but it was Scott who established it, and the Scott musical gear still looks best of any."

— John M. Conly, Atlantic Monthly



Instructions for the Model LM-35 wideband Multiplex Adaptor Kit

A = L
B = R

Introduction

The LM-35 is a wideband demodulator designed to provide superb stereophonic reception when used with any H. H. Scott Wideband tuner. It utilizes the identical multiplex circuitry that has made Scott multiplex equipment the standard by which all others are judged. The multiplex section is mounted on the chassis completely assembled, aligned, and tested. During the course of assembly you will be instructed to make certain connections to this preassembled unit. Outside of those specified do not make any adjustments, bend any coils, or turn any slugs. Any uncalled for changes will adversely affect the performance. Before beginning assembly remove all tubes and put aside for later use.

Check the parts

On page 24 of this manual is a descriptive list of the parts included. Before beginning the assembly it is recommended that you check all the parts with this list. It will insure that there are no missing parts, and will help you become familiar with the various items. If you should accidentally damage or misplace any parts, write to the LABORATORY KIT SERVICE DEPARTMENT at the factory immediately.

A four foot length of insulated wire has been supplied. It can be used to replace any missing wires or ones accidentally damaged. Simply cut off the length required and strip off $\frac{1}{4}$ " of insulation at each end.

Occasionally we may make minor substitution of parts. Such substitutions are carefully checked and the parts supplied will work as satisfactorily as those specified in the manual. These changes will be obvious and are mentioned here only to prevent confusion in checking the parts list. For example, .005 μ f capacitors are used interchangeably with .0047 μ f capacitors.

Tools Required

An alignment tool and a small screwdriver are provided. In addition, you will need a pair of long nose pliers, a regular size screwdriver, a pair of wire cutters, and a soldering iron or gun. A 35 watt (or more) pencil type soldering iron is actually the easiest to use. The iron should be supplied with a small tip. If a soldering gun is used, it should also have a small tip, and should be used carefully because of the enormous heat it supplies.



Simplified soldering and wiring instructions

All the solder needed to assemble the unit is supplied. If for any reason additional solder is needed, make sure that you obtain 60/40 ROSIN CORE SOLDER. Under no circumstance should you use Acid Core solder. All guarantees are voided if Acid Core solder is used.

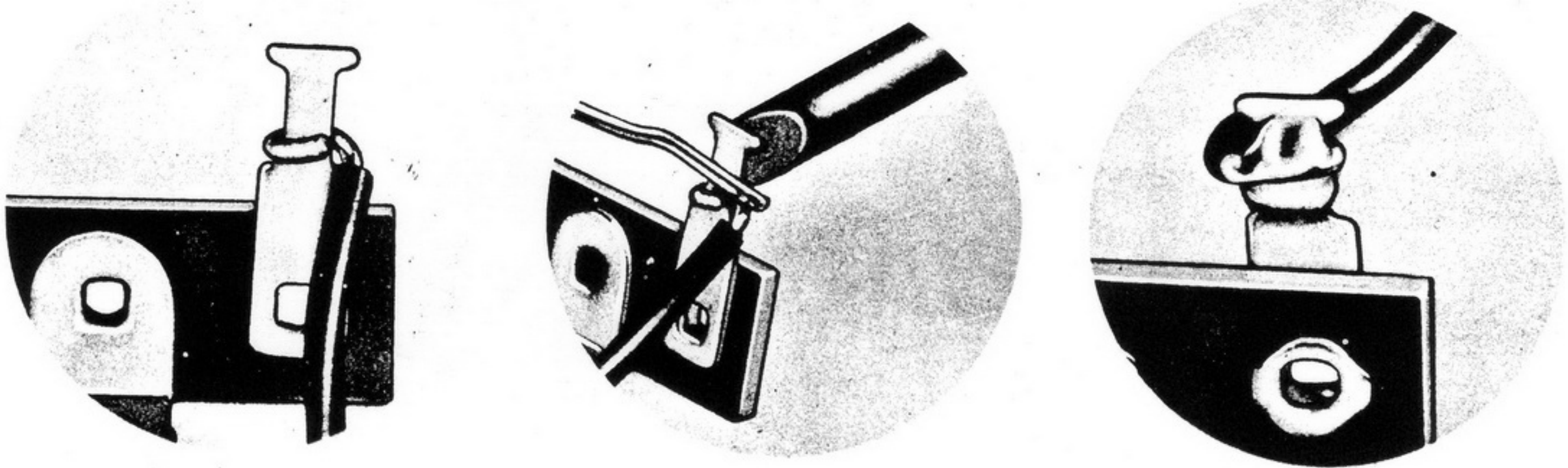

FIGURE 1

Here's how to solder joints correctly:

1. Before using the soldering iron or gun, the tip must be tinned for ease of use. First heat up the iron. Then when the tip is hot, wipe with a cloth till bright and shiny, and apply a generous amount of solder. Remove any excess. Repeat this process for all sides of the tip.
2. Make sure that all leads (wires) and terminals to be soldered are completely clean. Do not use fluxes or paste of any sort.
3. The leads should be mechanically secure before soldering. This does not mean wrapping leads around the contacts several times. It means a single turn around the contact which is then pinched tightly with the long nose pliers. If the wire is too large for bending, position the wire so that a good solder connection can still be made. (See Fig. 1.)
4. Leads on resistors, capacitors, and similar components are generally much longer than they need to be to make the indicated connections. In these cases, the excess leads should be cut off before the part is added to the chassis. In general, the leads should be long enough to reach their termination allowing for a little left over to make a good mechanical joint.
Sometimes a lead will not seem quite long enough to reach the desired mounting point. In such a case, the terminal lug can be bent slightly to make the connection possible.
5. Place a flat side of the soldering iron tip against the joint to be soldered until it is heated sufficiently to melt the solder.
6. Place the solder against the heated terminal (with the soldering iron still in contact) and it will immediately flow over the joint. Use only enough solder to thoroughly wet the

joint. Too much solder may cause short circuits. The soldering iron does not actually come into contact with the solder, only with the joint. It is the heated joint that melts the solder.

7. As soon as sufficient solder has flowed, remove the solder tube and then a second later, the iron. Use care not to move the leads until the joint has hardened (about 5 seconds). A good solder joint should appear to be bright and shiny. Check the joint for rigidity. If it is not firm and tight, reheat the joint and permit the solder *already present* to flow again. Sometimes a little more solder will have to be added.
8. When soldering certain of the components, such as diodes, it is advisable to use no more heat than is necessary. Excessive heat can damage these components.
9. Keep the soldering iron clean and bright by occasionally wiping with a rag. The iron does not have to be cooled for this purpose. If you have never done any soldering before, it would be an excellent idea to practice on scraps of wires before beginning.
10. The factory wired parts of your LM-35 can act as a guide to what good soldering looks like.

Basic electrical assembly procedure

Your adapter kit includes two separate sub-assemblies: the front (with all the controls and knobs), and the main (with all the tube sockets). You will construct each sub-assembly separately and then combine them to make a complete adap-

tor. The Symbol *F* refers to the front, and *M* to the main.

With the exception of the preassembled multiplex section, each terminal, tube, transformer, etc. has a code number (i.e. T1, V2, and so forth). Every pin on each of these terminals, or tube sockets is also numbered (i.e. pin 1, pin 2, and so forth). The instructions will call for a wire to be connected to pin 3, V1, for example. With the instructions will be a pictorial, clearly showing the connection to be made and its location. With this information you should experience no difficulty in making the correct connection.

A series of Part-Charts are provided with all the necessary resistors and capacitors mounted. Each chart applies to a particular page of the electrical assembly instructions.

For example—in the instructions that follow you will find a page marked "Assembly Group BF-2." The "B" indicates that this is part of the electrical assembly. The "F" indicates that you will be working on the "front." The "2" means that this is the second page of instructions for electrical assembly of the front. In the bag of Part-Charts, you will find a Part-Chart BF-2. Take this out and keep it next to you when working on this page. The first step on the page is called BF2-1 and refers to a 330K resistor. The first part on the Part-Chart is a 330K resistor. The pictorial on the top of the page will show exactly where this part will go. The part is mounted as directed and the step is checked off as completed.

The many wires used in the adaptor kit are packed in a small plastic envelope. This envelope contains two separate bundles, clearly marked. For example — Assembly Group BF-1 involves connecting a group of wires of different colors and lengths. Open the bundle of wires marked "front," and spread them out near you. The first step, BF-1, calls for a 5 $\frac{3}{4}$ " orange/white wire. From the orange/white wires select the ones of the appropriate length and hold them up to a ruler. Once you have the correct one, you may proceed as above.

IT IS IMPORTANT TO POSITION THE WIRES OR COMPONENTS IN THE SAME POSITION AS SHOWN IN THE PICTORIAL.

If the symbol — (S-) appears in the instruc-

tions after any connection, it means that the particular connection with all other wires on the same pin, should be soldered. After the "S" will appear a number. This number indicates exactly how many leads or wires are supposed to be connected to the terminal or pin in question. For example: connect an orange wire to pin 2, V6 (S-3). The soldering number (S-3) will always be printed in parenthesis, so it can be found quickly. It indicates that there should be 3 wires or leads (including the orange one) connected to pin 2, V6, and that all three of them are to be soldered. This provides an additional check for wiring errors.

Do not solder any connection that is not marked with an (S-). Other connections are yet to be made to this pin before it can be soldered. Frequently one end of a lead or component will be soldered while the other end will not (for the moment). The (S-) will only appear after the description of the end that is to be soldered. After completing the soldering, cross out the (S-) symbol with your pencil indicating that it has been done.

IMPORTANT: Mounted on the chassis of your LM-35 is a prewired and prealigned multiplex unit. This sub-assembly includes many parts that have been carefully positioned to provide precise performance. It also includes many preset adjustments which have been made with special laboratory equipment. DO NOT TURN OR MOVE ANYTHING UNLESS SPECIFICALLY TOLD TO BY THE INSTRUCTION BOOK. FAILURE TO OBSERVE THIS WARNING CAN MEAN SERIOUS DETERIORATION OF PERFORMANCE.

Types of Wire Provided

Regular hook-up wire — These are the standard insulated wires that you will be using most of the time. They will be found in bundles for the different portions of the assembly procedure.

Buss wire — This is a term used to describe short lengths of uninsulated wire. A roll of buss wire will be found in one of the hardware bags.

Mic Lapel — This is a type of cable which has one insulated length and one uninsulated length

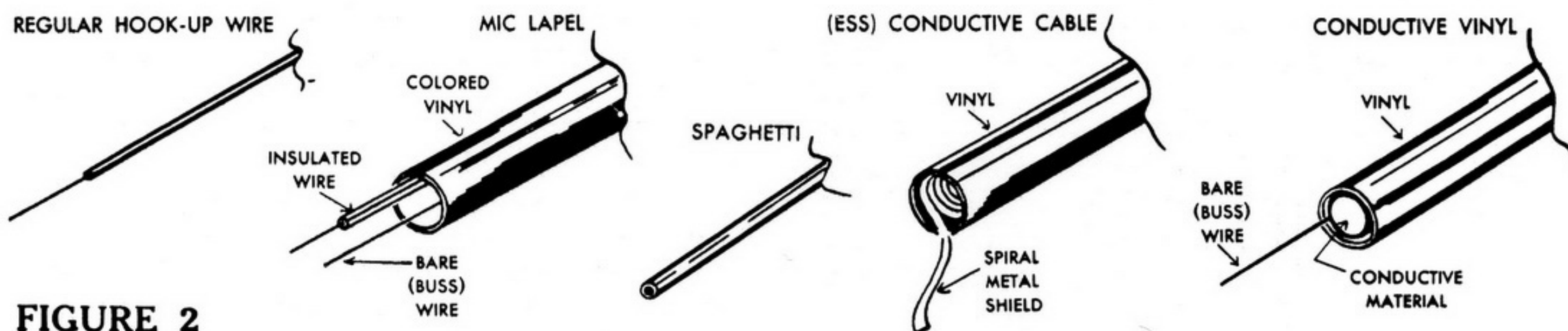

FIGURE 2

of buss wire inside. The cable itself has a brightly colored outside insulation.

Conductive Vinyl — This is large hollow tubing, usually either black or white in color, which has a hollow tube of conductive material inside. Between the outer layer of insulation and the inner layer of conductive material is a single strand of uninsulated buss wire. When using this cable, it is important to prevent the inner conductive material from becoming exposed and causing a short circuit. Always keep the outer insulation completely over it.

Conductive Cable (ESS) This is hollow tubing with a black or white outer insulation and a spiral metal shield inside.

Spaghetti — A common name to describe hollow black insulation material. This tubing is slipped over bare wires to provide protection.

What to do if you make a mistake

No matter how careful you may be, it is still possible to break something accidentally or to cut a lead too short. We might add that if you work when tired, try to do too much, too fast, then the possibility of mishap increases greatly. Nevertheless, it is easy to correct most common errors.

1. Cutting a wire or lead too short — If you cut the wire from one of the components too short you can easily correct it by taking a small piece of uninsulated wire (buss wire) and splicing it on as shown in Fig. 3. If a wire supplied is damaged, you can cut off a replacement from the 4 feet of spare wire supplied.

2. Breaking a terminal strip — The terminal strips are quite sturdy and will withstand a great deal of handling. Nevertheless, if you are ex-

tremely rough, a terminal pin can be broken off. If this happens, make all connections to the small hole below the broken pin. Be careful to avoid having any of the bare wires touch the chassis. If the phenolic material cracks but does not break off, you can continue on as the wires themselves will keep the broken piece in place.

In the unlikely circumstance that the entire terminal strip breaks off, it is necessary to replace it. Write to the Parts Department at the factory for a replacement. Drill out the rivet holding the broken strip, using a number 28 drill. Mount the replacement with a regular 6-32 x 1/4" machine screw, lockwasher, and nut.

Do not proceed unless you have read all the instructions given above.

Mechanical Assembly

Read each step completely before performing the operation specified. Check off each step as you complete it.

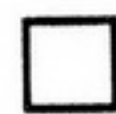

A1-1

Position the front chassis so that it is in the same position as shown on Fig. 4. Take the red pilot light and one of the special clips from the hardware bag. From the front of the chassis, insert the end of the pilot light having the two bare wires through the hole on the extreme left of the front chassis. From the rear of the chassis place the clip on the pilot light so that it bows slightly away from the chassis. (See Figure 4). Push down hard on the clip until it is down on the light as far as it will go.

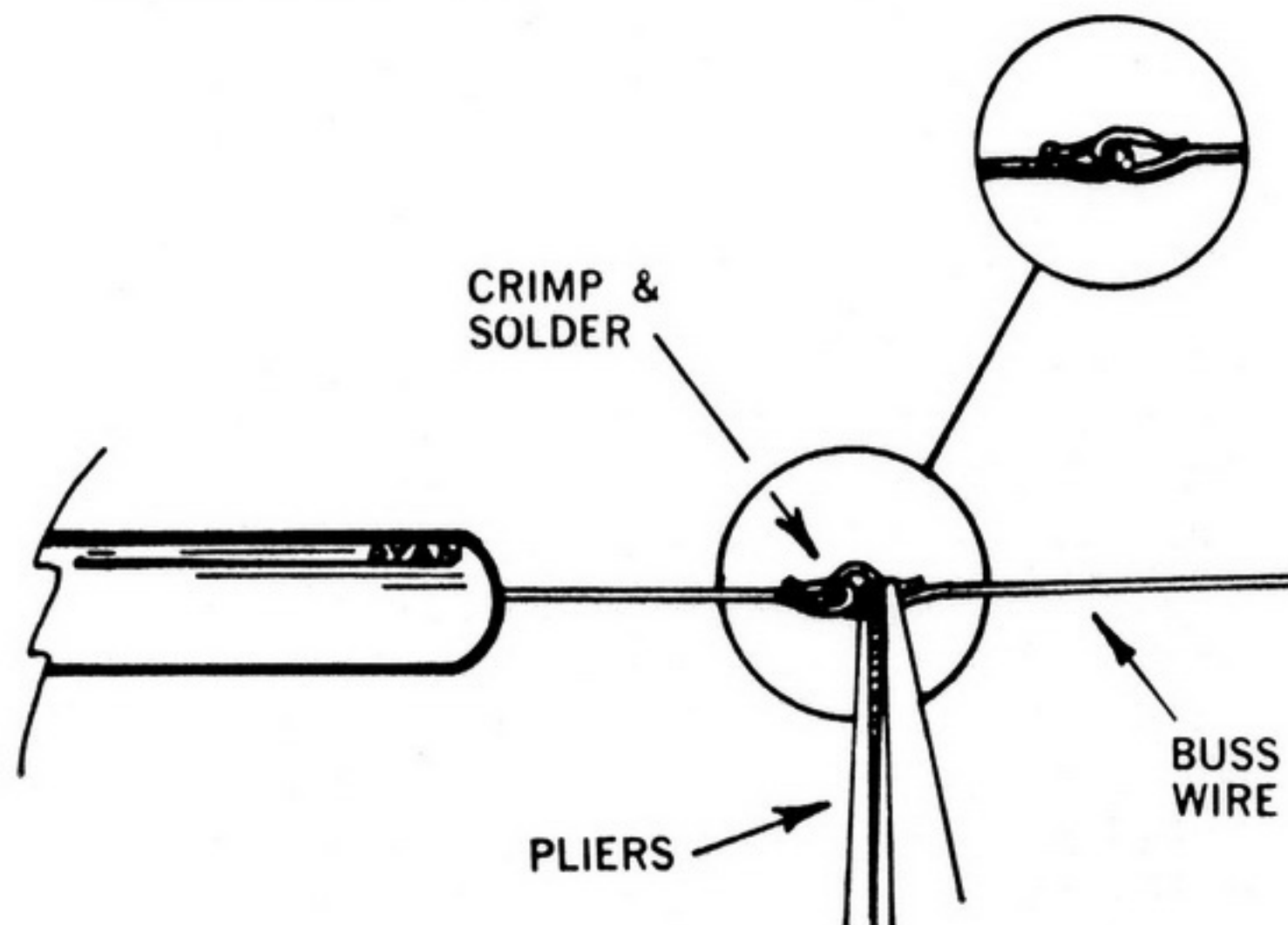

FIGURE 3

□ Using the hole to the extreme right of the chassis repeat the above procedure for the yellow pilot light.

A1-2

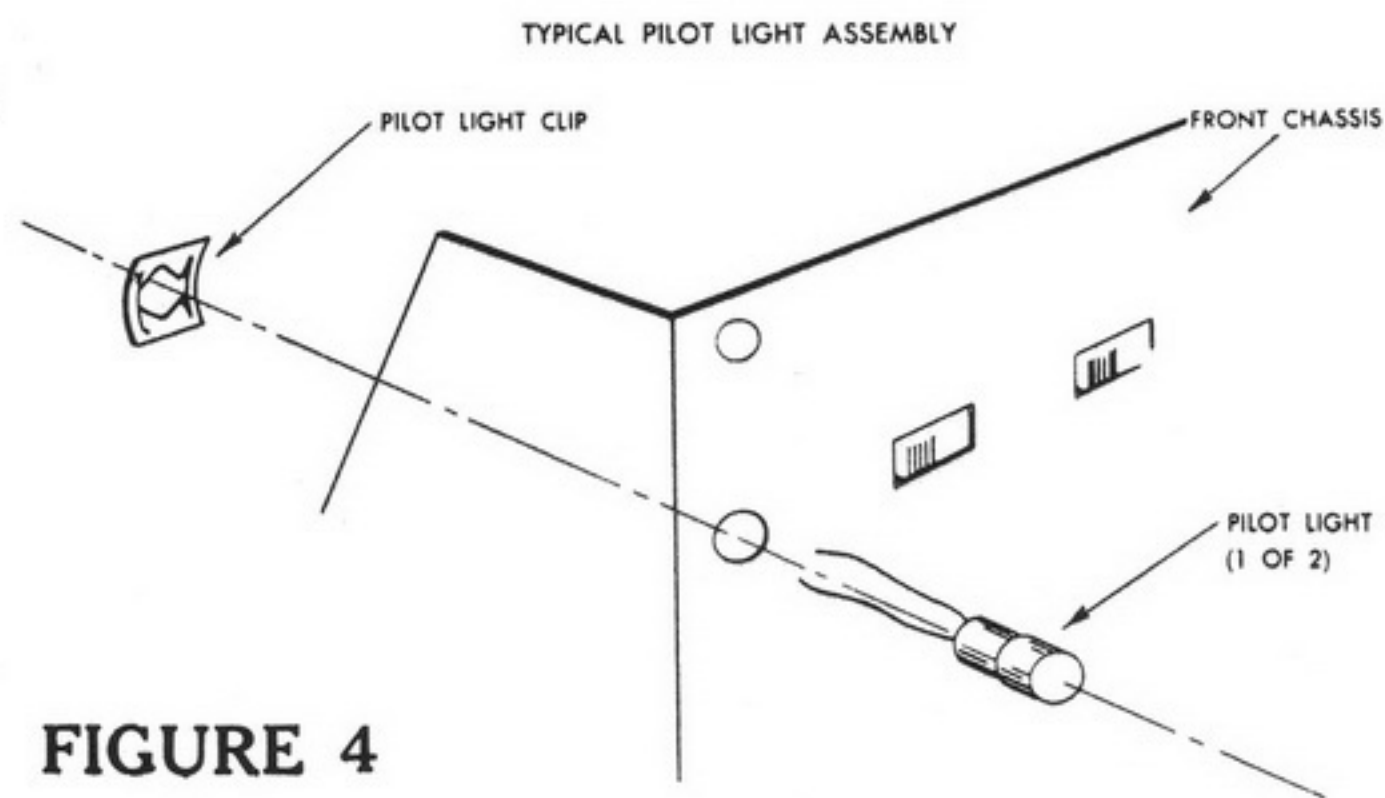

FIGURE 4

Electrical Assembly

INTRODUCTORY NOTES

To obtain the really fine performance this adaptor is capable of, all lead lengths from components (resistors and capacitors) must be as short as possible. Follow the diagrams closely. A careful inspection of the pre-assembled front end will give you many hints as to the proper approach for mounting and trimming the parts. Keep all parts as close to the chassis as possible. This refers to all components and insulated wires. Bare wires, of course, should not touch the chassis, unless instructions indicate otherwise.

The biggest source of mishaps, next to poorly soldered joints, are short circuits. A short circuit occurs when two uninsulated wires that are not supposed to, accidentally touch each other. It can also happen when a wire going towards one pin accidentally touches another pin nearby. The main body of a resistor or a capacitor is fully insulated so it does not matter if this part touches something. It is only the bare wires on the ends that you have to watch for. As the number of parts in the tuner starts to increase, you will realize how possible it is for short circuits to occur.

Extra quantities of black insulation material (spaghetti) have been supplied. Whenever you suspect that a short circuit may occur (either to the chassis, to another bare wire, or to another pin), slide a small piece of spaghetti over the bare wires in question. If you position the parts exactly as shown in the pictorials, you will not need to use spaghetti very frequently. However, it is better to be on the safe side if you have any doubts.

Check off each step as soon as it is completed.

Go slowly,
Read completely
and carefully...
HAVE FUN

Assembly Group BF-1

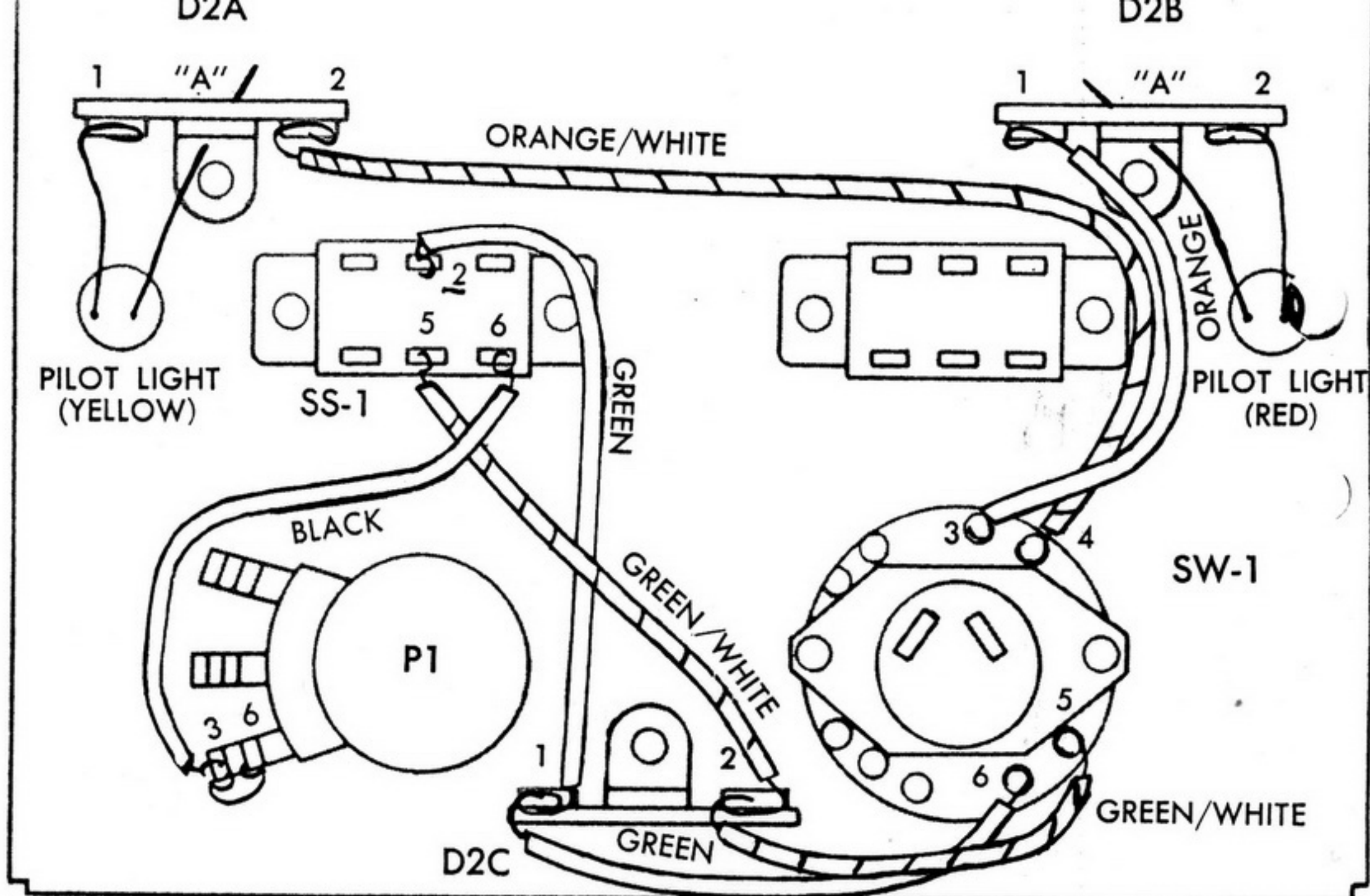

For these first few groups you will be working on the front chassis.

There is a bag of wires provided. Take the bundle marked "Front" and spread them out near you. Arrange them in groups according to color. Use a ruler to check lengths. The level control P1 has two decks. Pins 1, 2, and 3 are on the bottom deck (the one closest to the chassis), while pins 4, 5, and 6 are on the top deck (farthest from the chassis).

- BF1-1 Connect a 5 $\frac{3}{4}$ " orange/white wire from pin 2, D2A to pin 4, SW-1 (S1).
- BF1-2 Connect a 2 $\frac{3}{4}$ " orange wire from pin 1, D2B to pin 3, SW-1.
- BF1-3 Connect a 3 $\frac{1}{2}$ " green wire from pin 2, SS-1 to pin 1, D2C.
- BF1-4 Connect a 3 $\frac{1}{4}$ " green/white wire from pin 5, SS-1 to pin 2, D2C.
- BF1-5 Connect a 3 $\frac{1}{2}$ " green wire from pin 1, D2C to pin 6, SW-1, (S1).
- BF1-6 Connect a 2 $\frac{3}{4}$ " green/white wire from pin 2, D2C to pin 5, SW-1 (S1).
- BF1-7 Connect a 3" black wire from pin 6, SS-1 to pin 3 (bottom), P1.
- BF1-8 Connect a piece of buss wire from pin 3 (bottom), P1 (S2) to pin 6 (top), P1. Buss wire is described on Page 3, and will be found in the bag of wires. This must be cut to length. Keep buss wire short and make sure it does not touch the chassis or cause short circuits with exposed, bare parts.
- BF1-9 Connect one of the bare wires coming from the yellow pilot light to pin 1, D2A. Connect the other one to ground lug "A", D2A (S1).*
- BF1-10 Connect one of the bare wires coming from the red pilot light to ground lug "A", D2B (S1). Connect the other one to pin 2, D2B.*

(Check all wires, connections, and soldered joints before continuing. Make sure your layout looks exactly like the diagram above. Keep all insulated wires and leads as close to the chassis as possible.)

*Be careful that the bare wires coming from the pilot lights do not touch each other.

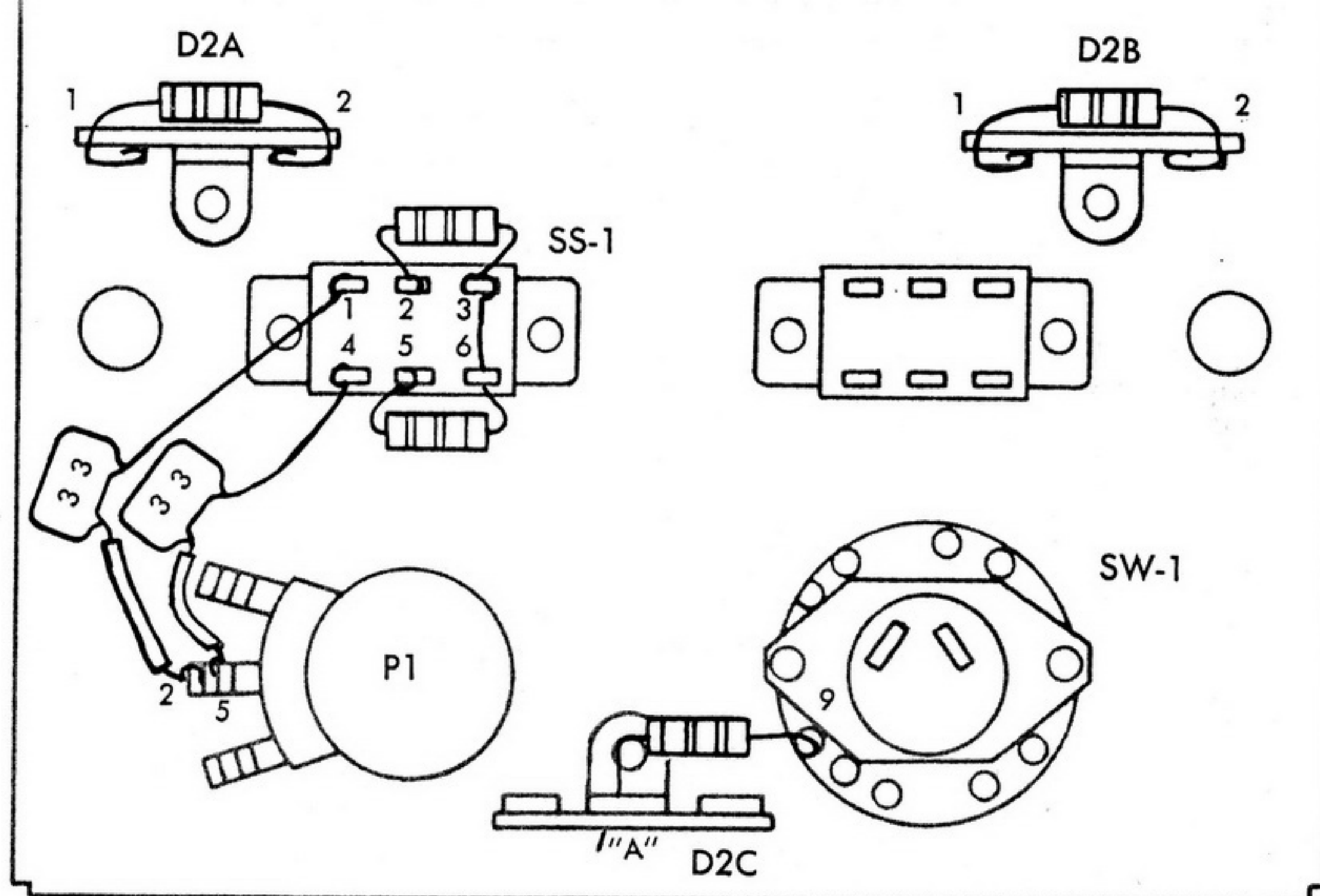

Assembly Group BF-2

A part chart for this group is included. Keep all leads short and make very small mechanical joints. If you wrap too much wire around the terminals when making your mechanical joints, you may very well have a piece sticking out that will cause a short circuit. As before, insure that uninsulated wires are not touching the metal covers on the controls, the metal chassis, or other uninsulated wires or terminals.

- BF2-1** Connect a 330K resistor (orange, orange, yellow) from pin 1, D2A (S2) to pin 2, D2A (S2).
- BF2-2** Connect a 330K resistor (orange, orange, yellow) from pin 1, D2B (S2) to pin 2, D2B (S2).
- BF2-3** Connect a 22M resistor (red, red, blue) from pin 2, SS-1 (S2) to pin 3, SS-1.
- BF2-4** Connect a 22M resistor (red, red, blue) from pin 5, SS-1 (S2) through pin 6, SS-1 (S3)* to pin 3, SS-1 (S2).
- BF2-5** Add a $\frac{3}{4}$ " piece of black insulation (a piece of insulation spaghetti will be found in the hardware bag) to one end of a CM-33. Connect this end to pin 2 (bottom), P1. Connect the other end to pin 1, SS-1 (S1).
- BF2-6** Add a $\frac{3}{4}$ " piece of black insulation to one end of a CM-33. Connect this end to pin 5 (top), P1. Connect the other end to pin 4, SS-1 (S1).
- BF2-7** Connect a 22K resistor (red, red, orange) from pin 9, SW-1 (S1) to ground lug "A", D2C (S1).

There will be two 470K resistors (yellow, purple, yellow) remaining on part chart BF-2. These two components will be assembled in steps BF3-15 and BF3-16, so do not misplace them.

*A wire passing through a pin counts as two connections to that pin.

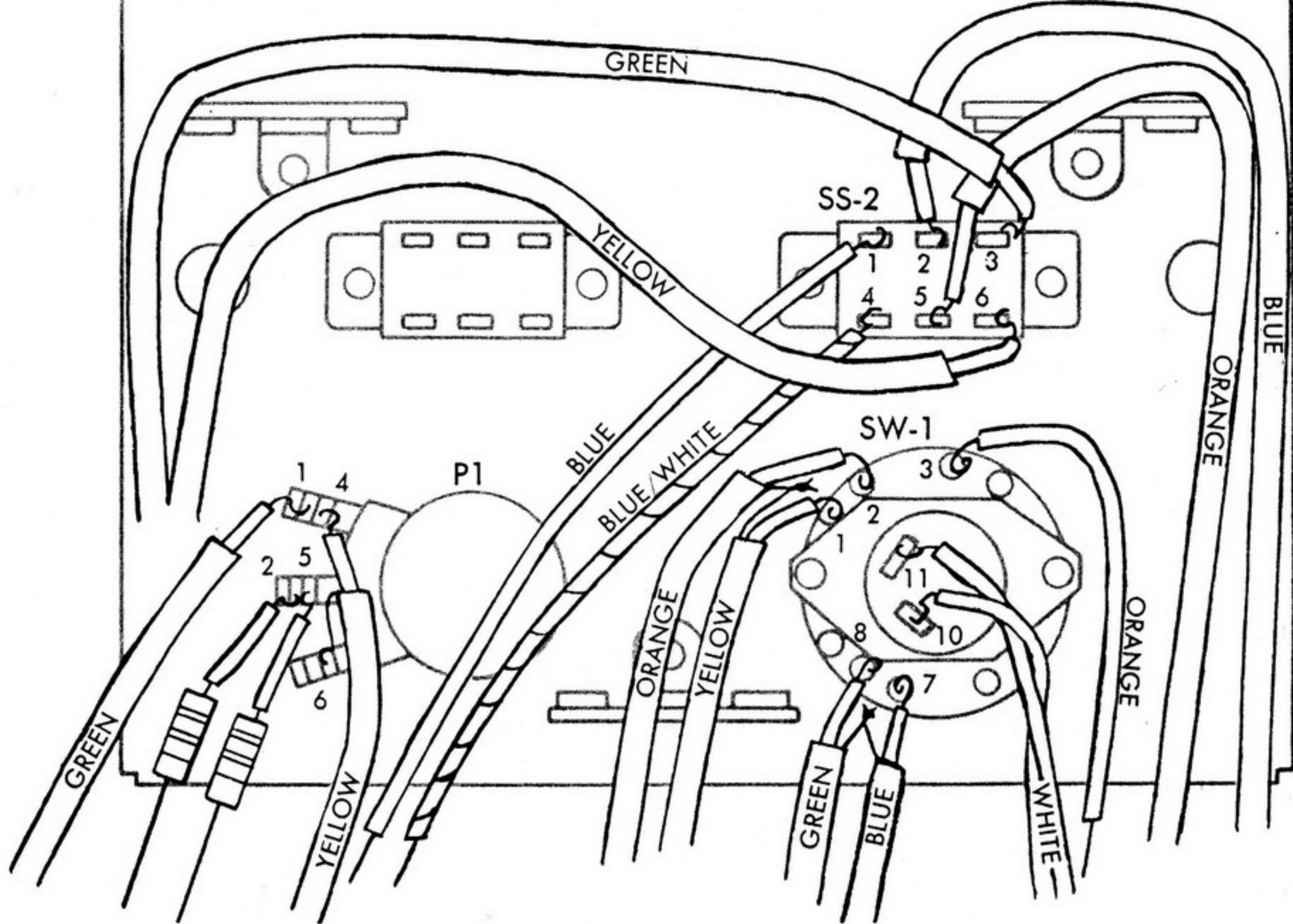

Assembly Group BF-3

In the following steps, only one end of the wires and components will be connected at this time. The other ends will be connected to the main chassis, later in the assembly of the kit.

From here on you will be soldering pins that have several wires attached. When you solder these pins, make sure that *all* the wires connected to the pin are fully soldered.

- BF3-1** Connect a 7" blue wire to pin 1, SS-2 (S1).
- BF3-2** Connect a 4½" blue/white wire to pin 4, SS-2 (S1).
- BF3-3** Connect a 16" orange wire to pin 3, SW-1 (S2).
- BF3-4** Connect a 10½" heavy white wire to pin 10, SW-1 (S1). Connect another 10½" heavy white wire to pin 11, SW-1 (S1). Twist these two wires together.
- BF3-5** Connect the insulated wire of a 5½" yellow mic label to pin 1, SW-1 (S1). Do not connect the bare wire at this time. A description of "mic label" wire will be found on page 3.
- BF3-6** Connect the insulated wire of a 5½" orange mic label to pin 2, SW-1 (S1). Wrap the bare wire at this end to the bare wire of the yellow mic label connected in BF3-5 (S2).
- BF3-7** Connect the insulated wire of a 5½" blue mic label to pin 7, SW-1 (S1). Do not connect the bare wire at this time.
- BF3-8** Connect the insulated wire of a 5½" green mic label to pin 8, SW-1 (S1). Wrap the bare wire at this end to the bare wire of the blue mic label assembled in BF3-7 (S2).

- BF3-9** Clip out the bare wire at one end of an 8 $\frac{1}{4}$ " green mic lapel. Connect the insulated wire at this end to pin 1 (bottom), P1 (S1).
- BF3-10** Connect the insulated wire of an 8 $\frac{1}{2}$ " yellow mic lapel to pin 4 (top), P1 (S1). Connect the bare wire at this end to pin 6 (top), P1 (S2).
- BF3-11** Clip out the bare wire at one end of a 17" orange mic lapel. Connect the insulated wire at this end to pin 5, SS-2 (S1).
- BF3-12** Clip out the bare wire at one end of an 18" blue mic lapel. Connect the insulated wire at this end to pin 2, SS-2 (S1).
- BF3-13** Clip out the bare wire at one end of a 17 $\frac{1}{2}$ " green mic lapel. Connect the insulated wire at this end to pin 3, SS-2 (S1).
- BF3-14** Clip out the bare wire at one end of an 18 $\frac{3}{4}$ " yellow mic lapel. Connect the insulated wire at this end to pin 6, SS-2 (S1).

The following parts will be found on Part-Chart BF2:

- BF3-15** Add a $\frac{3}{4}$ " piece of black insulation to one end of a 470K resistor* (yellow, purple, yellow). Connect this end to pin 2 (bottom), P1 (S2).
- BF3-16** Add a $\frac{3}{4}$ " piece of black insulation to one end of a 470K resistor* (yellow, purple, yellow). Connect this end to pin 5 (top), P1 (S2).

You have now completed most of the electrical assembly on the front. It is now time to check your work. Take out chart AF1 and follow instructions given on page 17 concerning double checking. You will note that on chart AF1 some pins have circled numbers next to them. The circled number indicates that more wires will be connected to this pin later. For double checking at this time only refer to numbers not circled.

*The two 470K resistors will be found on Part-Chart BF2.



Assembly Group BM-1

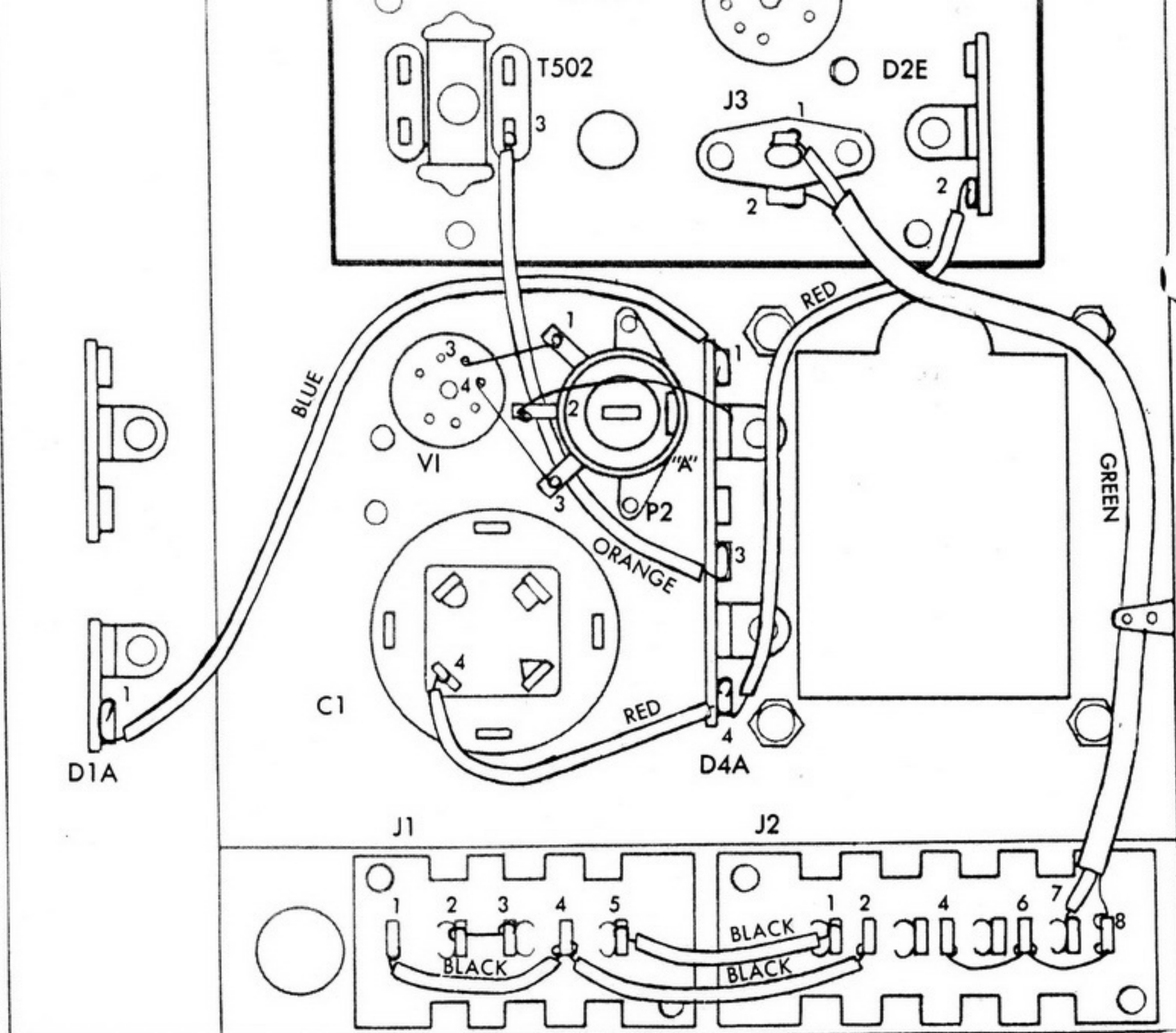

For the next few groups you will be working on the main chassis, "Z-MX-4" refers to the preassembled Multiplex section. Be careful when working on this section.

- | | | | | | |
|--------------------------|--------------|---|--------------------------|---------------|---|
| <input type="checkbox"/> | BM1-1 | Connect a buss wire from pin 3, V1 to pin 1, P2. | <input type="checkbox"/> | BM1-9 | Connect a 1 $\frac{3}{4}$ " black wire from pin 5, J1 to pin 1, J2 (S1). |
| <input type="checkbox"/> | BM1-2 | Connect a buss wire from pin 4, V1 to pin 3, P2. | <input type="checkbox"/> | BM1-10 | Connect a 5 $\frac{1}{4}$ " blue wire from pin 1, D1A to pin 1, D4A. |
| <input type="checkbox"/> | BM1-3 | Connect a buss wire from pin 2, P2 (S1) to ground lug "A", D4A (S1). | <input type="checkbox"/> | BM1-11 | Connect a 2 $\frac{3}{4}$ " red wire from pin 4, C1 (S1) to pin 4, D4A. |
| <input type="checkbox"/> | BM1-4 | Connect a buss wire from pin 4, J2 to pin 6, J2. When making connections to J1 and J2 use the hole on the top in all cases where the pin has two holes. | <input type="checkbox"/> | BM1-12 | Connect a 5" red wire from pin 2, D2E on the Z-MX-4 (S4)* to pin 4, D4A. |
| <input type="checkbox"/> | BM1-5 | Connect a buss wire from pin 6, J2 to pin 8, J2. | <input type="checkbox"/> | BM1-13 | Connect a 4" orange wire from pin 3, T502 on the Z-MX-4 (S1) to pin 3, D4A. |
| <input type="checkbox"/> | BM1-6 | Connect a buss wire from pin 2, J1 to pin 3, J1 (S1). | <input type="checkbox"/> | BM1-14 | Connect the insulated wire of a 5 $\frac{1}{2}$ " green MIC label to pin 7, J2 (S1). Connect the bare wire to pin 8, J2. Connect the insulated wire at the other end to pin 1, J3 on the Z-MX-4 (S2). Connect the bare wire to pin 2, J3 on the Z-MX-4 (S4).* |
| <input type="checkbox"/> | BM1-7 | Connect a 1 $\frac{3}{4}$ " black wire from pin 1, J1 to pin 4, J1. | | | |
| <input type="checkbox"/> | BM1-8 | Connect a 2 $\frac{1}{2}$ " black wire from pin 4, J1 to pin 2, J2 (S1). | | | |

*It will be necessary to resolder this pin after making the connection. Place your soldering iron on the pin and allow the solder already present to flow over the additional wire. This will apply throughout. This assembly of the kit as you make more connection to the Z-MX-4. In some cases, it may be necessary to add an additional amount of solder in order to obtain a properly soldered joint.

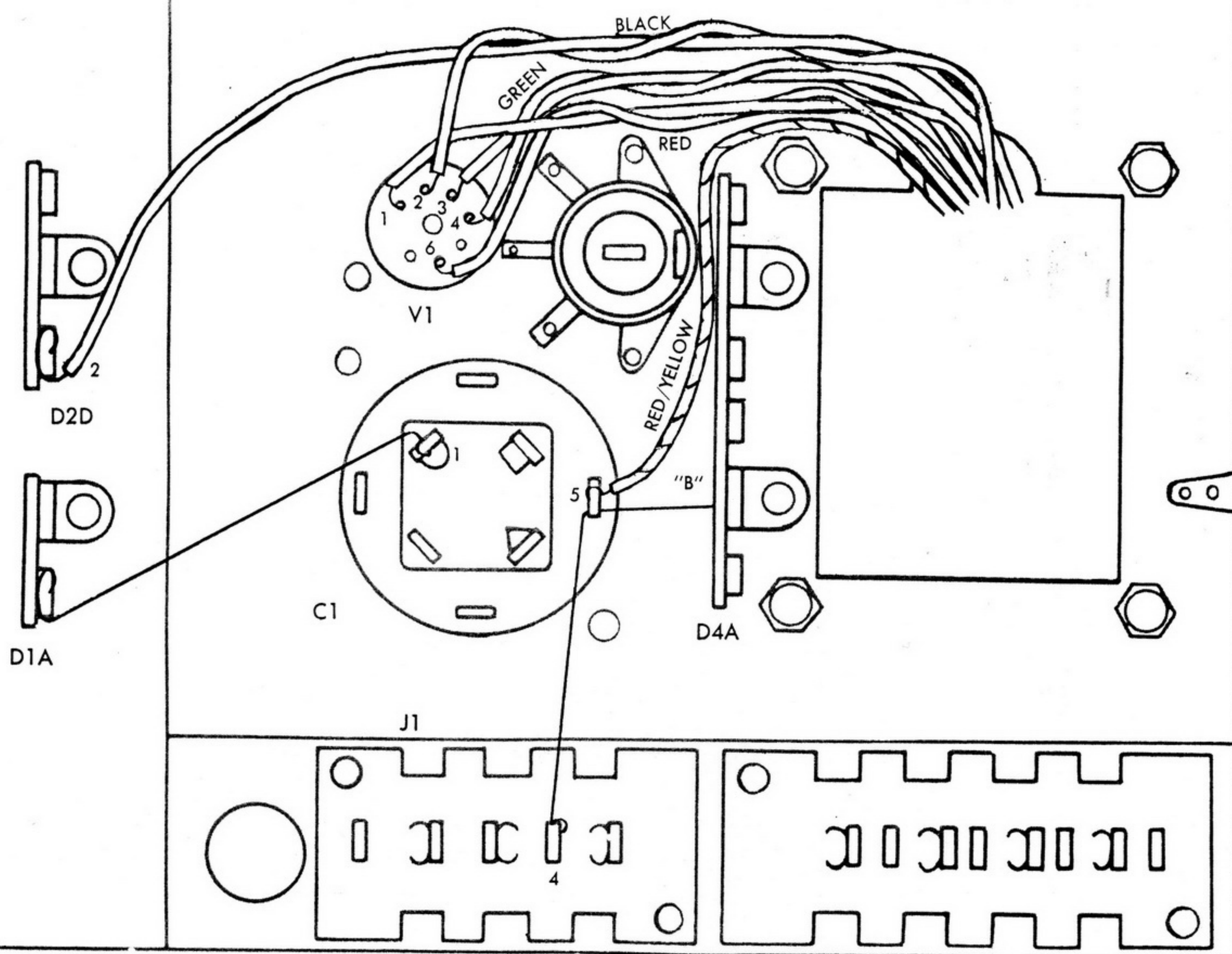

Assembly Group BM-2

The following wires are coming from the transformer:

- BM2-1** Connect the red/yellow transformer wire to pin 5, C1.
- BM2-2** Twist the two black transformer wires together. Connect one to pin 2, D2D and the other one to pin 2, V1.
- BM2-3** Twist the two green transformer wires together. Connect one to pin 3, V1 (S2). Connect the other one to pin 4, V1, (S2).
- BM2-4** Twist the two red transformer wires together. Connect one to pin 1, V1 (S1). Connect the other one to pin 6, V1 (S1).
- BM2-5** Connect a buss wire from pin 1, D1A to pin 1, C1 (S1).
- BM2-6** Connect a buss wire from pin 4, J1 through pin 5, C1 (S3)* to ground lug "B", D4A (S1).

*A wire fed through a pin counts as two connections to that pin.

Mechanical Assembly A-2

Mount the front chassis to the main with six 6x1/4" sheet metal screws. (See Figure 5.)

AZ-2

After mounting the front to the main, slide one of the 7 1/2" pieces of heavy black insulation over the blue and orange mic lapels coming from SS-2, the orange wire coming from SW-1, and the two heavy white wires coming from SW-1. Position this piece of insulation so that it runs along the left side of the pre-assembled multiplex section. (See Assembly Group BM-3.)

Take the remaining 7 1/2" piece of insulation and place it over the green and yellow mic lapels coming from SS-2. Position this insulation along the right side of the multiplex section. (See Assembly Group BM-3.)

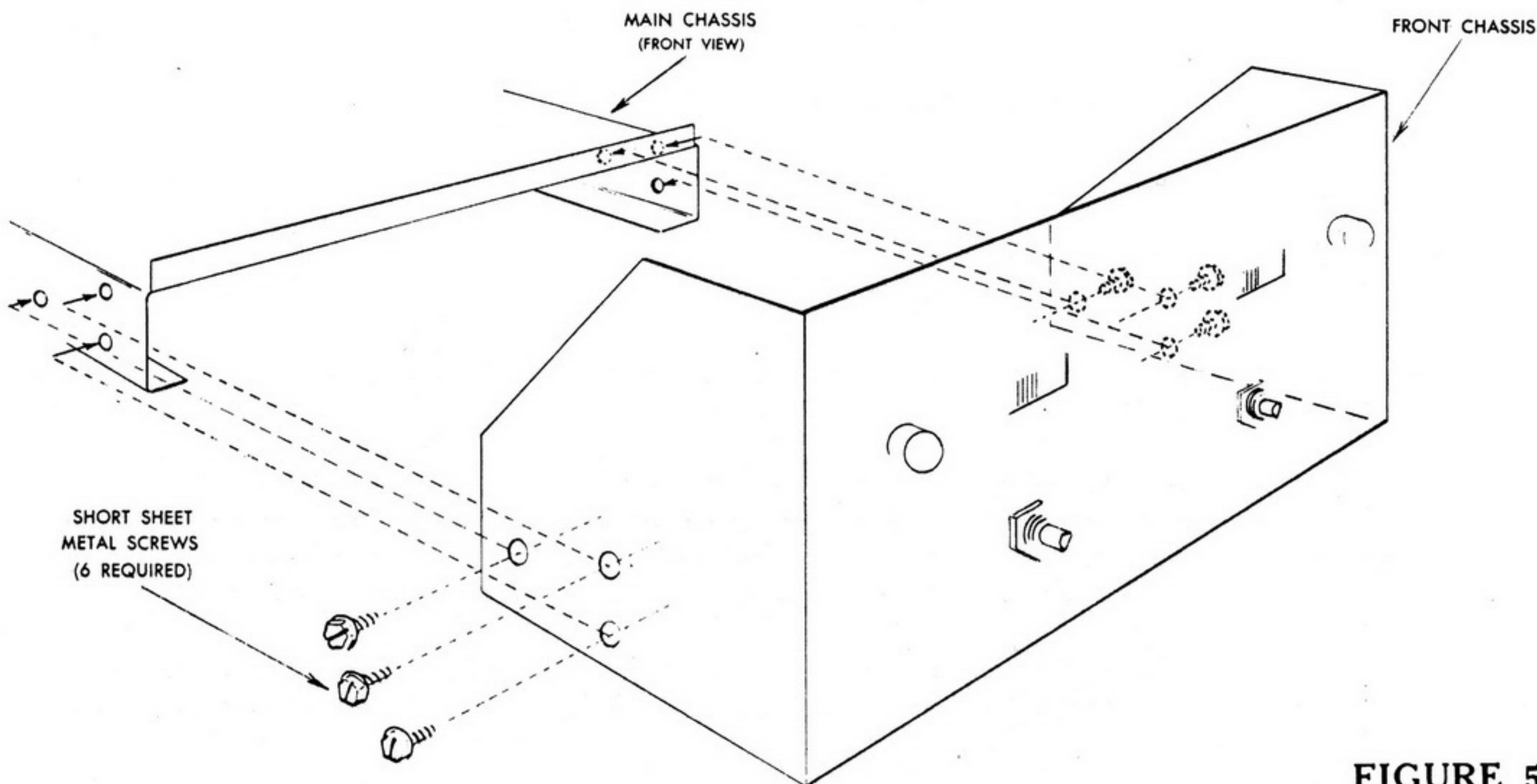
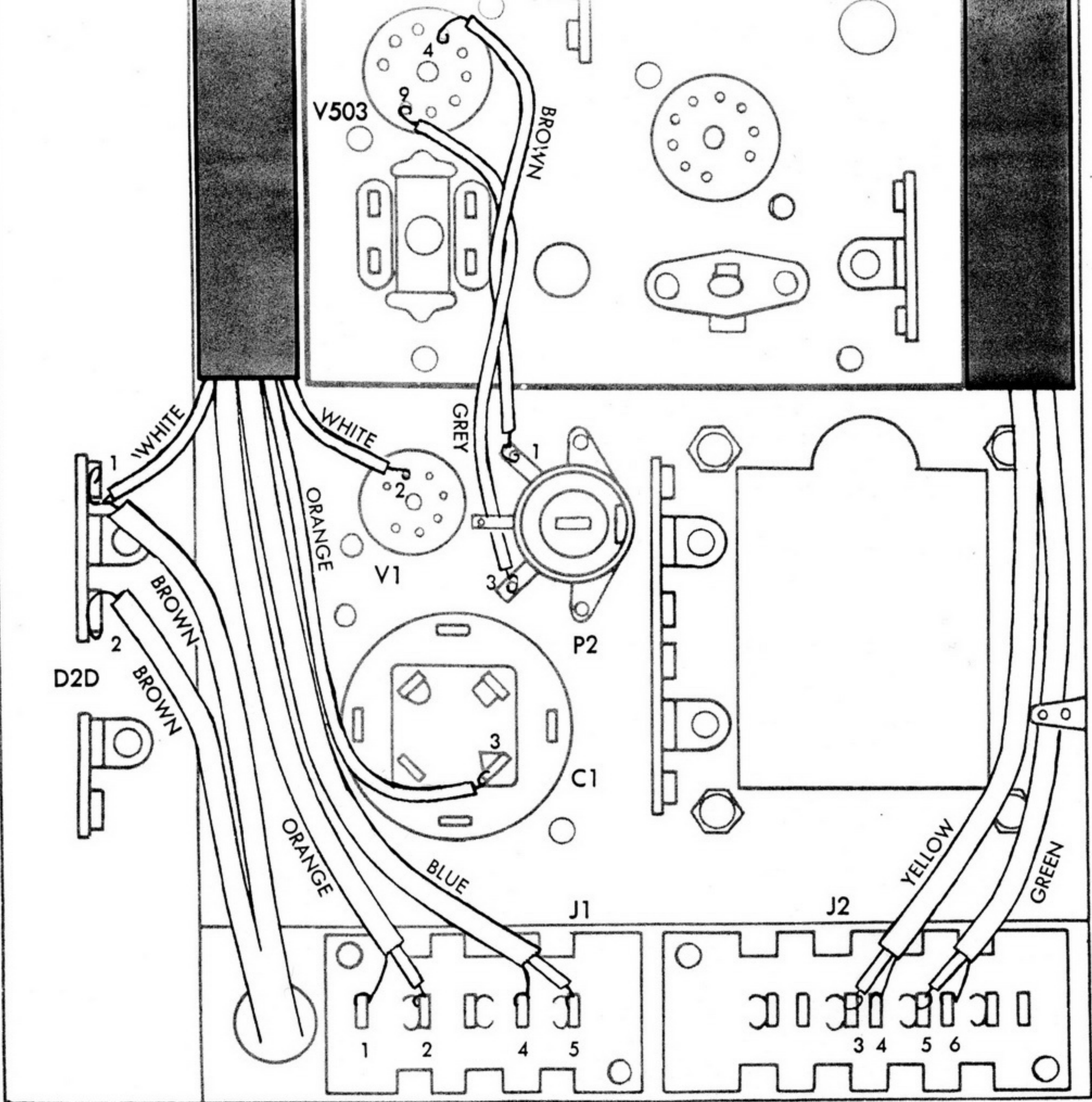

FIGURE 5

Assembly Group BM-3

(Note: Keep all component leads as short as possible and position them close to the chassis exactly as shown in the pictorial. You will now be soldering joints that have many leads connected to them. Make sure that all the leads on the joint are soldered. You will also find yourself soldering joints which are hard to reach because other leads and components are in the way. Carefully bend these interfering items out of the way so that you can insert the soldering iron without causing damage. Once the joint has been soldered, carefully re-position all the wires and components that you bent away.)

- BM3-1** Connect either one of the brown line cord wires to pin 2, D2D (S2). Connect the other line cord wire to pin 1, D2D.
- BM3-2** Connect the brown wire coming from V503 on the Z-MX-4 to pin 1, P2 (S2).
- BM3-3** Connect the grey wire coming from V503 on the Z-MX-4 to pin 3, P2 (S2).



The wires referred to in steps BM3-4 through BM3-7 are the ones passing through the black insulation to the left of the multiplex section.

- BM3-4** Connect one of the heavy white wires to pin 2, V1 (S2). Connect the other heavy white wire to pin 1, D2D (S2).
- BM3-5** Connect the orange wire to pin 3, C1.
- BM3-6** Connect the insulated wire of the blue mic label to pin 5, J1 (S2). Connect the bare wire to pin 4, J1 (S4).
- BM3-7** Connect the insulated wire of the orange mic label to pin 2, J1 (S2). Connect the bare wire to pin 1, J1 (S2).

The wires referred to in the following steps are the ones passing through the insulation to the right of the multiplex section.

- BM3-8** Connect the insulated wire of the yellow mic label to pin 3, J2 (S1). Connect the bare wire to pin 4, J2 (S2).
- BM3-9** Connect the insulated wire of the green mic label to pin 5, J2 (S1). Connect the bare wire to pin 6, J2 (S3).

Assembly Group BM-4

In the following steps you will be connecting the ends of the wires and components that were previously connected to the front. All of these connections will be made to the pre-assembled multiplex section (Z-MX-4). It will be necessary to resolder these connections as described previously.

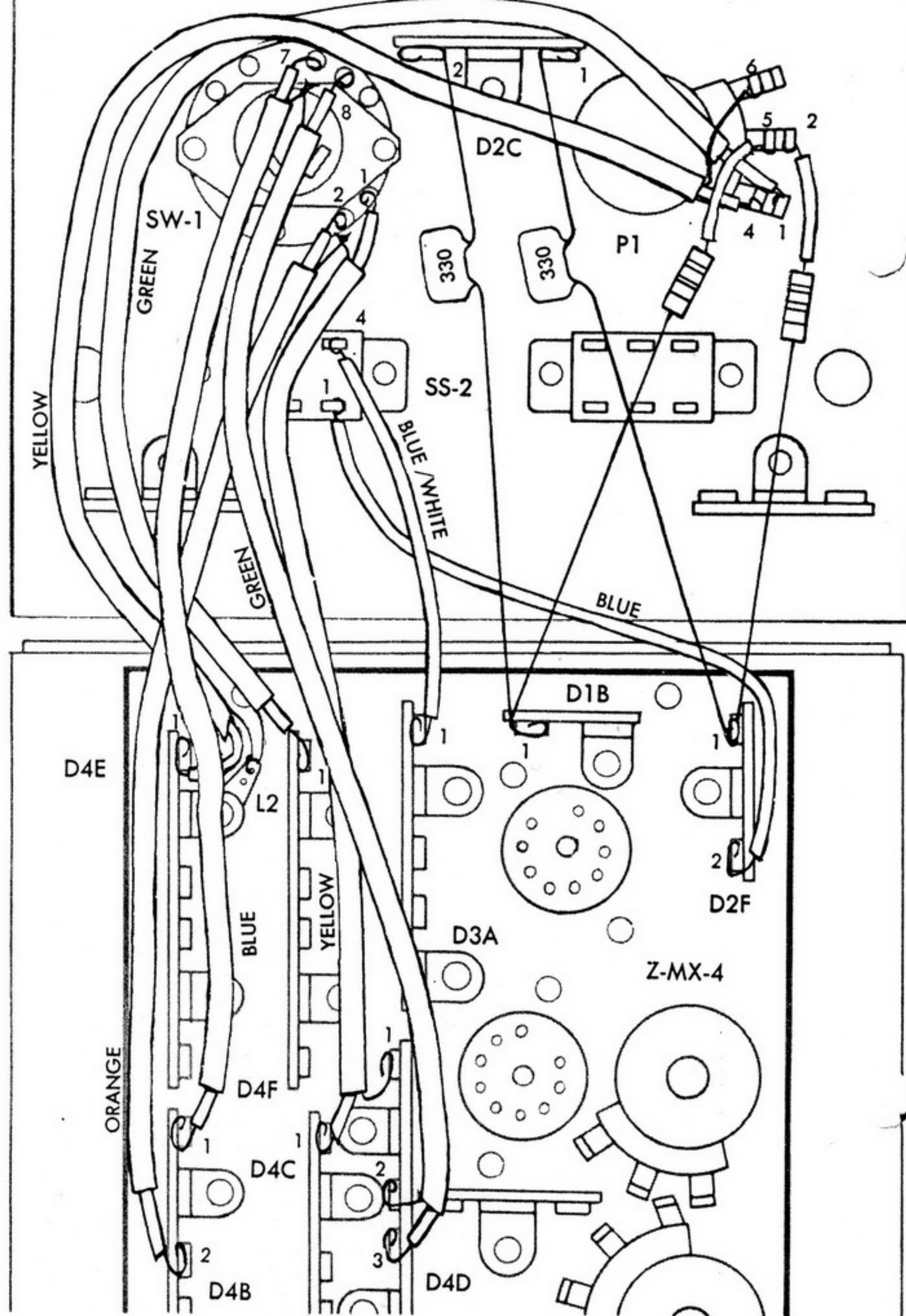

Connect the blue wire coming from SS-2 to pin 2, D2F (S4).

BM4-1

Connect the blue/white wire coming from SS-2 to pin 1, D3A (S4).

BM4-2

Clip out the bare wire of the orange mic lapel coming from SW-1. Connect the insulated wire at this end to pin 2, D4B (S3).

BM4-3

Connect the insulated wire of the yellow mic lapel coming from SW-1 to pin 1, D4C (S3). Connect the bare wire to pin 1, D4D (S3).

BM4-4

Connect the insulated wire of the yellow mic lapel coming from P1 to pin 1, D4E (S2). Connect the bare wire to L2.

BM4-5

BM4-6 Connect the insulated wire of the green mic lapel coming from P1 to pin 1, D4F (S2). Connect the bare wire to L2 (S2).

BM4-7 Connect the insulated wire of the green mic lapel coming from SW-1 to pin 3, D4D (S3). Connect the bare wire to pin 2, D4D (S3).

BM4-8 Clip out the bare wire of the blue mic lapel coming from SW-1 and connect the insulated wire to pin 1, D4B (S3).

BM4-9 Connect the 470K resistor (yellow, purple, yellow) coming from the bottom deck of P1 to pin 1, D2F.

BM4-10 Connect the 470K resistor (yellow, purple, yellow) coming from the top deck of P1 to pin 1, D1B.

The following parts will be found on Part-Chart BM-5.

BM4-11 Connect a CM330 from pin 2, D2C (S3) to pin 1, D1B (S4).

BM4-12 Connect a CM330 from pin 1, D2C (S3) to pin 1, D2F (S4).

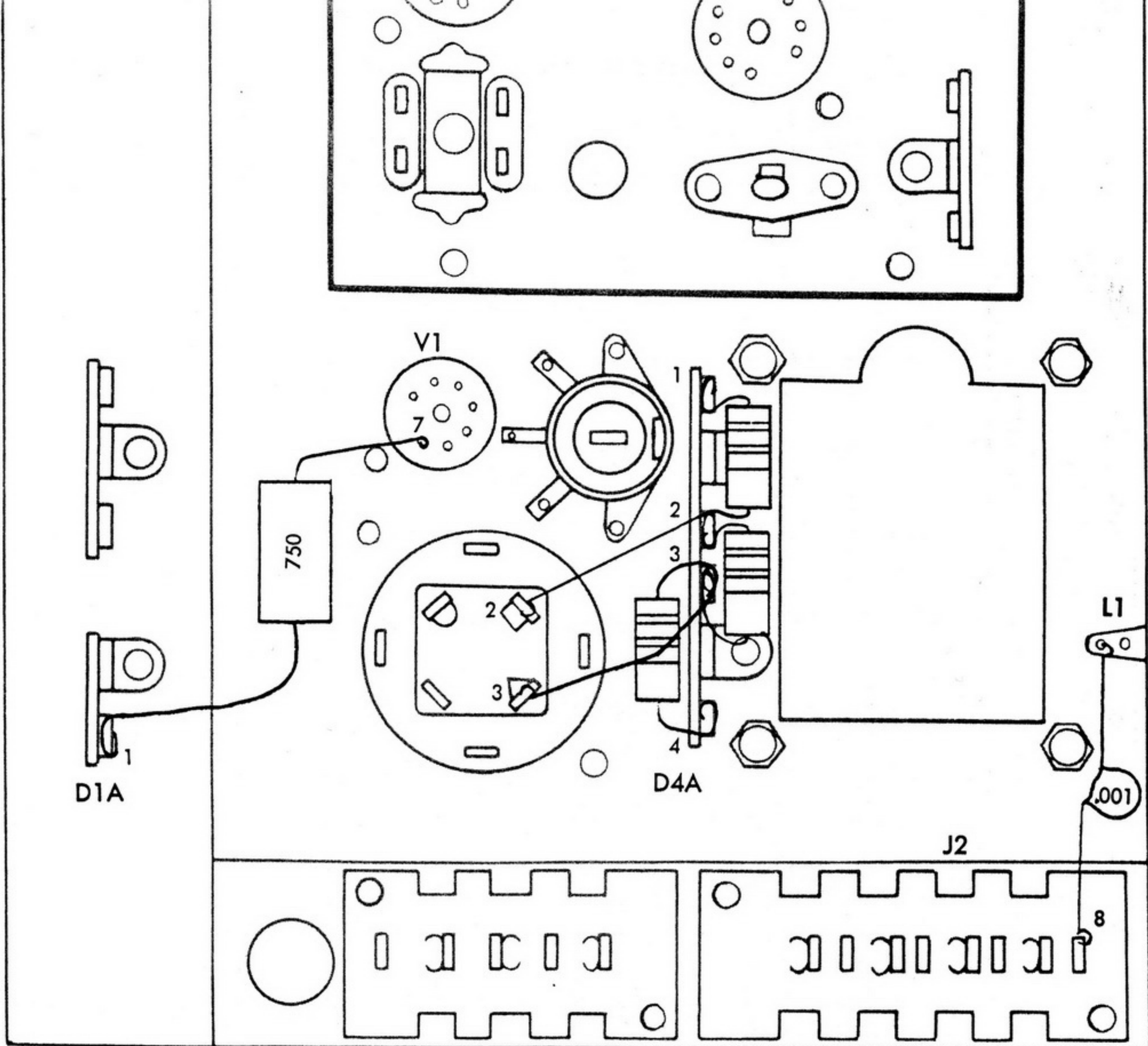

Assembly Group BM-5

- BM5-1** Connect a large 470 ohm resistor (yellow, purple, brown) from pin 1, D4A (S2) to pin 2, D4A.
- BM5-2** Connect a large 470 ohm resistor (yellow, purple, brown) from pin 2, D4A to pin 3, D4A.
- BM5-3** Connect a large 1K resistor (brown, black, red) from pin 3, D4A to pin 4, D4A (S3).
- BM5-4** Connect an RW-750 from pin 1, D1A (S3) to pin 7, V1 (S1).
- BM5-5** Connect a CC-.001 from pin 8, J2 (S3) to L1 (S1).
- BM5-6** Connect a buss wire from pin 2, C1 (S1) to pin 2, D4A (S3).
- BM5-7** Connect a buss wire from pin 3, C1 (S2) to pin 3, D4A (S4).

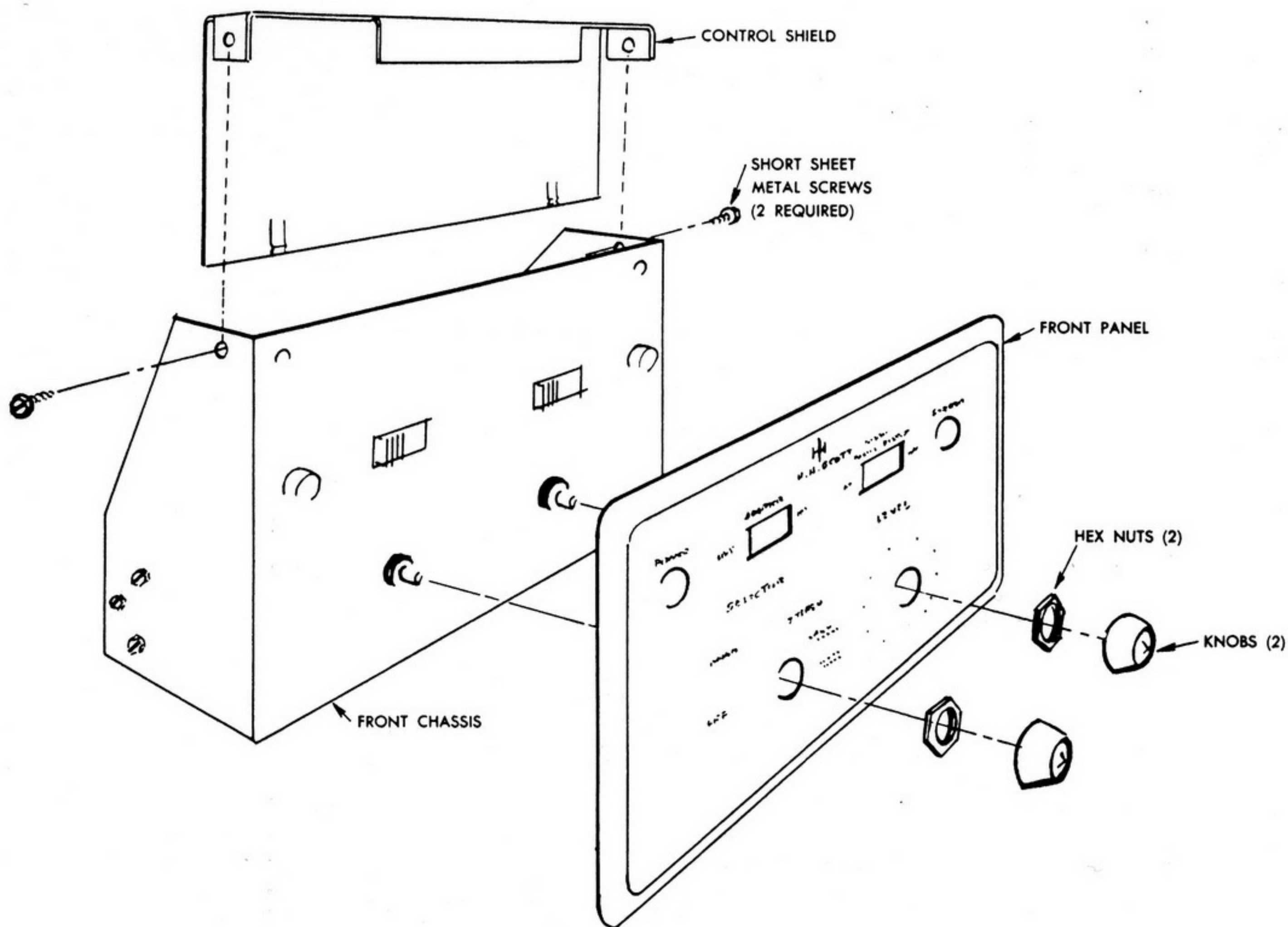

FIGURE 6

Mechanical Assembly A-3

- A3-1 The tube sockets are identified as to number and type on the top side of the chassis. Using this as a reference, mount the tubes into their proper sockets. Be sure that the 12AU7 having the painted top is inserted in tube socket V503.
- A3-2 Remove the hex nuts from the shafts of the controls. Place the front panel over these shafts and replace the hex nuts. (See Figure 6.)
- A3-3 Place one of the brown knobs on the shaft of the selector switch (the control having the flat on the shaft). Tighten the set screw with the small screwdriver provided.
- A3-4 Turn the shaft of the remaining control (level control) full counter clockwise. Place a brown knob on the shaft so that the indicator line on the knob is at "O". Tighten the set screw.

Very Important!

THE DOUBLE CHECK SYSTEM

The electrical assembly is now complete. It is time to pause for a moment and make sure that there are no errors, and that every joint has been soldered properly. It is quite understandable that at this stage of the assembly there will be a tremendous incentive to forge ahead quickly to finish the job. Unfortunately this attitude can cause you to overlook a small error that will lead to serious and expensive damage to your adaptor.

In extensive evaluation tests we had LM-35 kits built by a wide variety of people. Over 90% of the kits worked perfectly upon completion. Of this percentage, virtually everyone had taken the trouble to follow this double checking procedure, and most of them reported catching small errors. In those units that did not work we discovered that malfunction could, in every case, be traced directly to skipping of the double-check. Simple miswiring errors or short circuits prevented proper operation of the adaptor. Stop for a moment, RELAX, and be sure to check over your work.

An easy method of doing this has been provided. Call in a friend or another member of the family. Have them look over charts AF1 and AM1. On these diagrams of the underside of the chassis, a series of numbers have been placed next to each pin or terminal. These numbers indicate the number of wires and leads (including those from resistors or capacitors) that have been soldered to that pin. If circled and uncircled numbers are given, use the circled numbers as all connections have now been made. While you count off the number of leads on each pin and terminal, your assistant can check your count against the chart. When you count the leads going to pin 1 of V3, your helper will observe that this agrees with his chart and place a small check mark on it. This will be continued until the entire adaptor is checked over. It will seldom take more than 10 minutes for this complete check.

While you are counting the wires, you can also be checking for short circuits and proper soldering. It would be very handy if you had a tool with a small sharp point (like an ice pick) to probe the connections and make certain they are soldered properly. A pencil with a sharp point can also be used. Even the most meticulous worker can make a mistake or have a poorly soldered joint. LOOK SHARP! Move every lead and wire a little bit to insure it is not accidentally causing a short circuit with some other wire or pin.

If a mistake is caught and it involves a component which is now too short to reach the correct pin, refer to Fig. 3 on splicing a piece of buss wire. This will work quite well and eliminate the need for purchasing a replacement.

Final Assembly

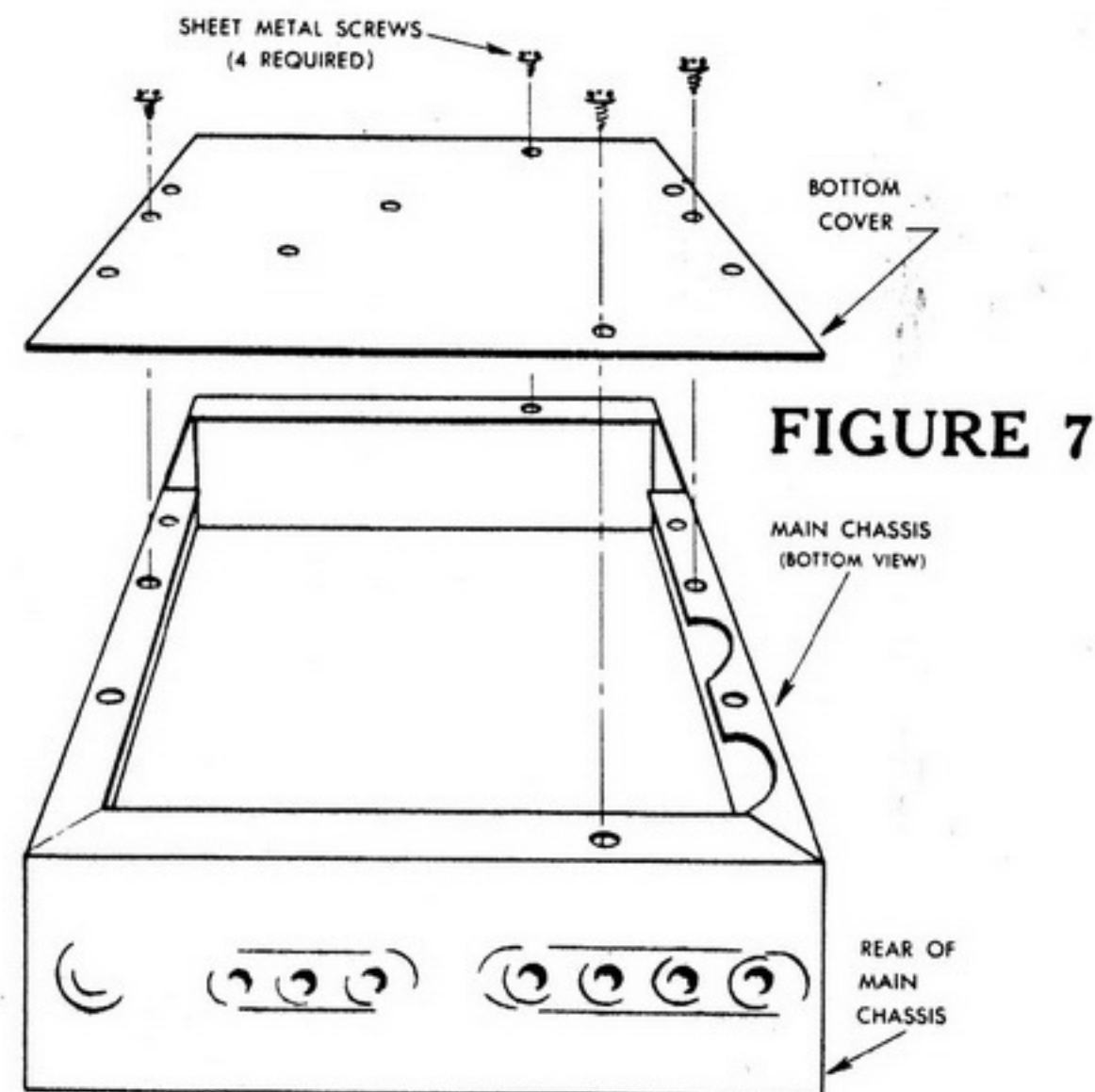

Turn the chassis over and shake it violently. This is to get all the little pieces of wire out of the unit. Make certain that there are no pieces caught in any crevices or in the tube sockets or condenser can bases. This could cause short circuits.

This is the appropriate time to make sure that the adaptor is working. Turn the selector switch on the front to "Off" (extreme counterclockwise). Insert the line cord into an AC wall outlet (do not use with DC). Turn the selector switch to "mono". Watch for any signs of overheating or smoking under the chassis, on top, or behind the front panel. The tubes should all light up slowly and normally and not glow bright red or flash. At the first sign of trouble, turn off immediately and go through the wiring carefully to make sure there are no poorly soldered joints or short circuits. Make sure you have no miswires or errors. If all is normal, turn off the adaptor, remove the line cord, and continue.

Assemble the control shield with two 6x1/4" sheet metal screws. (See Figure 6.)

Assemble the bottom cover with four 6x1/4" sheet metal screws. (See Figure 7.)

Hum adjust. Connect adaptor to your tuner and amplifier as described in the following section on "Connections." Turn level control down on adaptor and up on amplifier until a slight hum is audible. Rotate the hum adjust on the top rear of the adaptor until this hum is at a minimum.

Congratulations!

Now . . . sign your personal label "This kit was built by —" . . . turn your tuner on . . . relax . . . and listen to one of the finest FM multiplex stereo systems ever made.



In Case of Difficulty

No matter how careful you are, a mistake is possible. Don't panic! First, make sure each tube is in the proper location. Then go back to the assembly notes and check off each step with the written instructions and the pictorials. Or if possible, have someone else do this for you. Often a fresh approach may disclose mistakes that you might be consistently overlooking. While checking for errors, carefully probe each and every wire, lead, component, and part to make sure there

are no short circuits and poor solder joints.

In case the fuse has blown (the unit will not light up) it is very likely that there is a short circuit. Before replacing the fuse (instructions for this will be found in the service notes enclosed) search for the cause.

In case the unit lights up but does not operate properly, voltage readings are supplied on the schematic. If you can obtain a good vacuum tube voltmeter (VTVM) use the voltage readings for locating the portion of the circuit that is malfunctioning.

If none of the above suggestions help in curing the problem, you should write to our Laboratory Kit Service Dept. for prompt assistance. There is no charge for this help. The engineers in this department are thoroughly familiar with all aspects of the kit, and can probably localize the cause of your difficulty. However, you must be very explicit in describing your problem. Mention all the approaches you have undertaken to cure it. Describe all the symptoms and signs that may be involved. With complete information supplied, the possibilities of a cure through the mail are greatly increased.

Service

When all else fails the facilities of the H. H. Scott Laboratory Kit Service Department and the vast network of Authorized Warranty Service Stations are available to you. You will be charged a fixed fee of \$10.00 for each unit that is submitted either to the factory or to a Warranty Station within the warranty period. This fee will be in addition to any parts that have to be replaced. If the unit is still within the 90 day warranty period (see description of the Warranty Policy below), then the charge for parts will be governed by this policy.

Many H. H. Scott dealers have service facilities and are fully competent to repair this kit. These dealers are not governed by our price policy and can charge any fee they wish. This fee should be ascertained before service is begun.

Only the factory and certain of the warranty stations have the necessary equipment to service the multiplex section. Before any servicing is done to this section, check with the factory to locate the names of those warranty stations qualified.

The service policies described above only apply to completely assembled instruments constructed according to the instructions supplied. Any unit that is not complete, or has been modified in any way will not be accepted. Instruments showing the use of fluxes and acid core solder will also not be accepted.

Warranty

To protect your investment, H. H. Scott, Inc. warrants that for a period of three months from the date of purchase, all parts shall be free of defects in materials and workmanship under normal use and service. H. H. Scott, Inc. will replace any defective parts upon the return of same to the factory, either by the customer, the dealer, or a warranty service station. There will be no charge for this replacement.

This warranty does not apply to any parts damaged during the course of handling and assembling the kit. No other warranty, either expressed or implied, shall apply to this unit.

Packing For Shipping

If it becomes necessary to return the instrument to the factory, it is possible to use your container for shipping. Place the adaptor into the box. Tie a shipping tag to the adaptor with your name, address, and a complete list of the problems involved. Fill the rest of the box with crumpled newspaper so that the LM-35 does not move around. Close and seal the box with strong tape or a heavy cord. Insure for its full value and Ship by railway express prepaid to:

**Laboratory
Kit Service Dept.
H. H. Scott, Inc.
111 Powder Mill Road
Maynard, Mass.**

Operating Instructions

This superb Wide-Band adaptor has been designed to provide maximum quality when used with any H. H. Scott Wide-Band tuner to receive multiplex stereo broadcasts. We do not recommend using this adaptor with tuners of other manufacture although it is perfectly possible that this adaptor will function with some other tuners. We cannot, however, guarantee that multiplex reception under these conditions will match FCC transmission specifications. These specifications can be matched when you use an H. H. Scott Wide-Band tuner with the H. H. Scott Model LM-35 Wide-Band Multiplex Adaptor.

To get the best results, it is essential that you read these instructions completely and carefully.

DESCRIPTION OF CONTROLS

Red light indicates power on.

Amber light indicates adaptor set for stereo multiplex reception.

Adaptor Switch

In — for regular operation of the adaptor. In this position, all the controls on your tuner are inoperative except for power and tuning knob (and the Normal-Distant switch in 310C and 310D).

Out — when the Adaptor switch is in this position, your FM tuner functions exactly as it did before you added your adaptor to the system. Use the *out* position when there are no stereo multiplex broadcasts.

Selector

Off — turns off the power to the adaptor.

Mono — permits you to listen to the main FM channel only. Useful when the subcarrier is of extremely poor quality.

Stereo — *Subchannel noise filter out* — for normal stereo reception.

Stereo — *Subchannel noise filter in* — provides stereo reception, but reduces noise in the multiplex subcarrier. Does not affect main FM carrier, but does reduce separation slightly.

Stereo Noise Filter

In — reduces high frequency noise on both the main FM carrier and the multiplex subcarrier. Does not reduce stereophonic separation.

Out — removes the filter for normal operation.

Level

When the Adaptor switch is in the *in* position, this control adjusts the volume level of both channels.

Connections

It's easy to connect your new adaptor
to your H. H. Scott System

The diagrams on this page supply the simple information needed to connect the adaptor to your H. H. Scott tuner and your stereo amplifier. In cases where your tuner has both a high level and a low level output (variously described as tape, audio, etc.) it is recommended that you use the low level outputs. This assumes that you are using a high gain amplifier with better than 0.7 volt sensitivity on the tuner inputs (any H. H. Scott amplifier meets this specification). If you are using a low gain amplifier you may have to use the high level outputs on your FM tuner to get sufficient volume.

The cable going to Channel B input of the LM-35 is not necessary for stereo reception. It is simply a convenience. If you are listening to a monophonic broadcast, you will have signal at both speakers without changing any switch positions on your amplifier.

Three shielded audio cables of the type you are already using to connect your tuner to the amplifier have been provided. If additional cables are needed, these can be easily obtained from your dealer.

For optimum performance, the cable length between the tuner and adaptor should be no more than three feet; between the adaptor and amplifier, ten feet maximum.

STEP BY STEP OPERATING INSTRUCTIONS

Before proceeding with the actual operation of the adaptor make sure you understand the function of each switch as described under "Description of Controls." In particular make sure you understand the **Adaptor** switch. When the **Adaptor** switch is in the *in* position, all controls on the LM-35 are in operation and all the controls (except power, tuning, and Distant-Normal switch on 310C and 310D) on your FM tuner are inoperative. When the **Adaptor** switch is *out*, the adaptor is out of the system. When you want to listen to FM stereo multiplex broadcasts, slide the **Adaptor** switch to *in*. When there are no stereo multiplex broadcasts slide the switch to *out*.

TO LISTEN TO STEREO MULTIPLEX BROADCASTS

1. Select a station on your FM tuner known to be broadcasting stereophonic sound via multiplex transmission.
2. Slide **Adaptor** switch to *in*.
3. Slide **Stereo Noise Filter** to *out*.
4. Set **Selector** switch to *Stereo, Subchannel Noise Filter Out*.

5. Adjust the **Level** control for proper volume (this control operates both channels). An easy way to tell if this **Level** control is set properly is to turn the **Selector** switch to *Mono*. If the overall loudness does not change when you switch the **Adaptor** switch between *in* and *out*, then the **Level** setting is correct.
6. Set the amplifier tone and loudness controls to suit your taste.

TO LISTEN TO STEREO MULTIPLEX BROADCASTS WITH SOME BACKGROUND NOISE 1, 2, 3, 4 as above.

If you notice that the sound is somewhat noisy (make sure that it isn't record surface noise being broadcast by the FM station), turn the **Selector** switch to *Mono*. If the noise disappears, return the **Selector** switch to *Stereo, Subchannel Noise Filter In*. If the noise is still present in the *Mono* position, return the **Selector** switch to *Stereo, Subchannel Noise Filter Out*; and slide the **Stereo Noise Filter** switch to *in*.
5 and 6 as above.

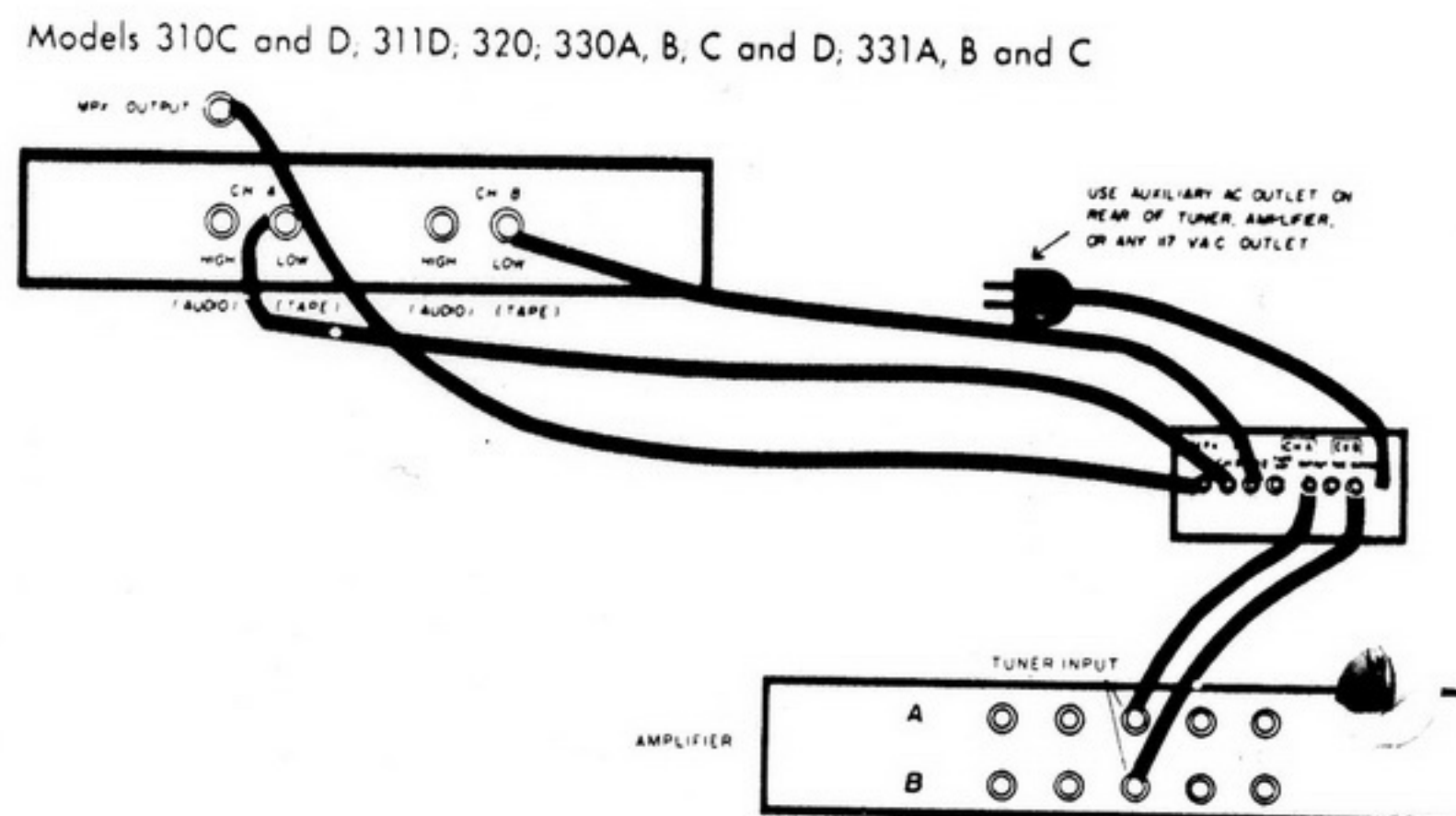
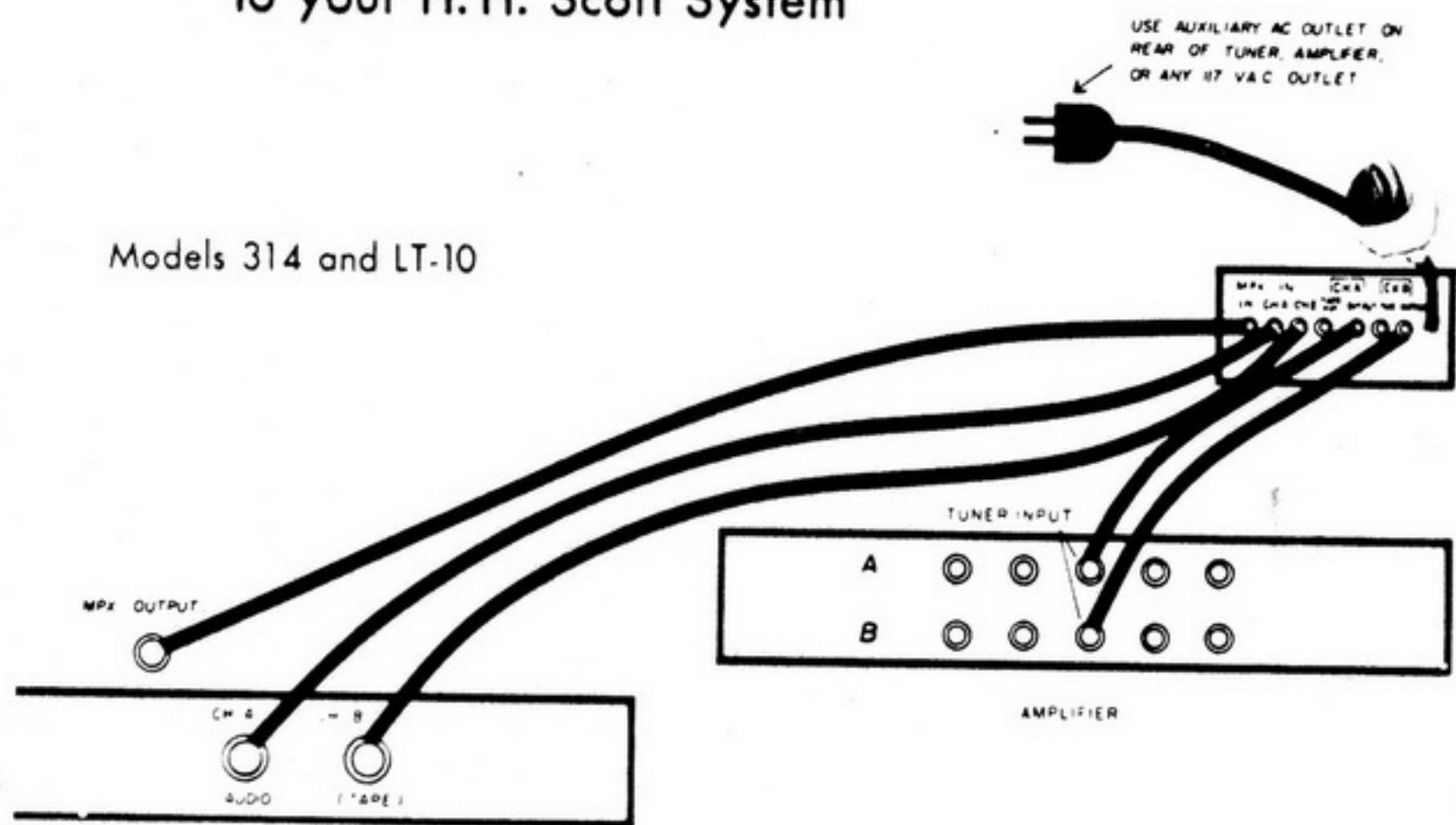

es:

On Models 310C, 310D and 311D the two low outputs are next to each other, rather than as depicted in diagram. Also use MPX output as shown on diagram.

On Model 320, you are now using Channel A and B outputs to your amplifier. Disconnect these cables from amplifier and run them to adaptor. Keep 320's front-panel slide switch in "normal monophonic" position. Also use output as shown on diagram.

On Models 330A and B and 331 A, B and C, correct outputs are labeled "Binaural." Also use MPX output as shown on diagram.

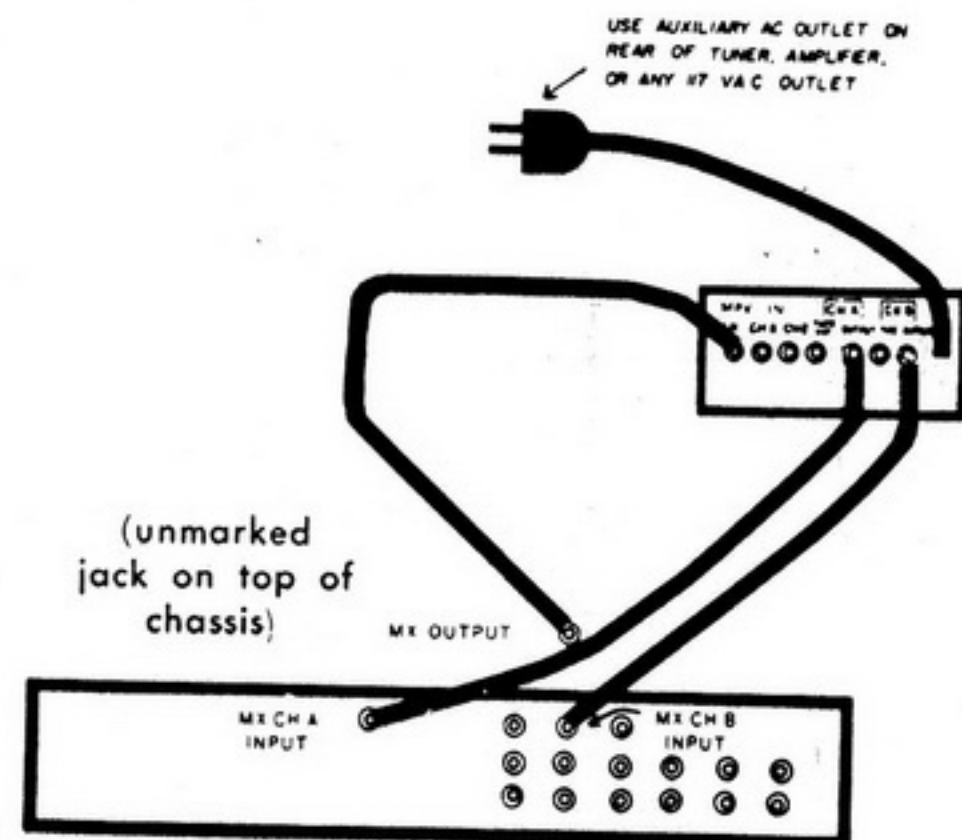
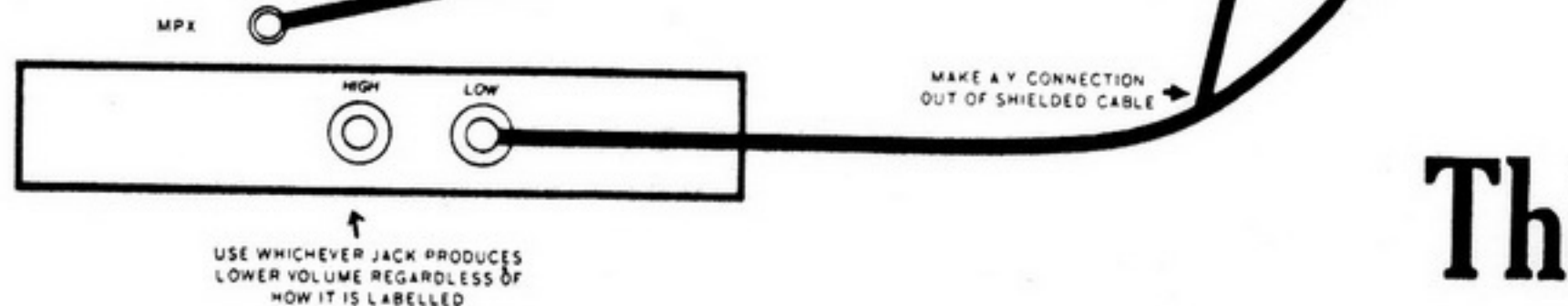

Things To Watch For

Multiplex stereo broadcasting is a new experience for most FM stations. Certain problems may arise since their own equipment and operating techniques may not be developed to the point where you can consistently expect the ultimate in performance in the beginning. Here are some hints and suggestions to help you improve on poor radio station broadcast techniques:

Background music — Multiplexing has been used by many broadcast stations to transmit background music to restaurants, offices, factories, etc. The FCC-approved stereo multiplex system does not interfere with this additional source of station revenue in any way. Without this additional income, many FM stations would not be able to stay on the air and bring you their wonderful good music programs.

You will not be able to receive these background music programs with any adaptor which meets the new FCC specifications. However, occasionally, if a station is using a subcarrier in the range of the stereo subcarrier channel for background music, you may hear some interference effects (like whistles) on your music system. This will only happen if you are using your FM tuner for regular FM reception and the LM-35 Adaptor switch is in the *in position*. This interference will not appear with a station using their subcarrier for stereo. It can easily be eliminated by keeping the Adaptor switch in the *out* position for normal FM reception as we suggested in the operating instructions.

Also, on very rare occasions you will find broadcasting stations that are transmitting two multiplex subcarriers, one for stereo and one for background music. In such cases there may be some interference between the two subcarriers. This can be corrected by any or all of the following suggestions:

TO LISTEN TO REGULAR MONOPHONIC FM BROADCASTS OR FM/AM BROADCASTS

1. Slide **Adaptor** switch to *out*. (You can turn the **Selector** switch to *off* if you desire to conserve electricity. However, whether the LM-35 is on or off — YOU MUST SLIDE THE ADAPTOR SWITCH TO *OUT* IF YOU DESIRE TO USE YOUR TUNER BY ITSELF.)
2. Set controls on your tuner and amplifier as desired.

SPECIAL NOTES AND SUGGESTIONS

310D and 310C — Both these tuners incorporate a special **Distant-Normal** switch which was primarily designed to give improved response with multiplex. When listening to a stereo multiplex broadcast, slide this switch into the *Distant* position. For regular FM listening, the *Normal* position is preferred.

399 — This combination tuner-amplifier already incorporates a switch on the front panel to provide for either multiplex reception or regular FM/AM, phono, tape usage. When using the 399 for stereo multiplex turn the **Input Selector** switch on the 399 to *FM-FM, MX Stereo* position. When using the 399 for other purposes, turn the **Input Selector** to the desired position. Because of this special switching on the 399, it is not necessary to move the 335 Adaptor switch away from *in* at any time.

- (a) Tune in the station more carefully.
- (b) Reposition your antenna.
- (c) Reverse the antenna leads.
- (d) Use a better and more directional antenna.

Distortion when the **Selector** is set for *stereo*, which disappears when the **Selector** is turned to *Mono* is primarily due to transmitter problems as discussed above. This can easily happen in areas with many hills or tall buildings that cause reflections. However, some improvement is possible in many cases by any or all of the above four suggestions.

HOW TO INSTALL YOUR SCOTT ADAPTOR OUT-OF-SIGHT

The LM-35 adaptor can be put permanently out of sight. In this way, cabinetry problems are eliminated and no additional control panels are needed.

Regardless of which Scott tuner you own, use the following arrangement for connecting the various cables (if you own a Scott tuner *other than* an LT-10, 310C, 310D, 311D, 314, 320, 330A, 330B, 330C, 330D, 331B, 331C, use a "Y" cable, as described previously in the instructions, from the tuner's audio output to the amplifier). 399 owners should follow the previous instructions.

This arrangement will permit regular FM reception (or AM-FM reception in the case of the AM-FM tuners) when the amplifier's **Input Selector** is in the *Tuner* position and the stereo FM

multiplex reception when the amplifier's **Input Selector** is in the *Extra* position.

Before setting the LM-35 out of sight—where it will be inconvenient to reset the controls, set the LM-35's controls in the following manner:

Adaptor switch — *In*.

Stereo Noise Filter — *Out*.

Level — the **Level** control of the LM-35 should be adjusted in the following manner: With the LM-35's **Selector** switch in *Mono*, tune in a station and switch the *amplifier's Input Selector* between **Tuner** and **Extra**. Adjust the adaptor's **Level** control until the volume does not change when the *amplifier's Input Selector* is switched from *Tuner* to *Extra*.

Selector — after adjusting the **Level** control as above, set the **Selector** in the *Stereo-Subchannel Filter Out* position.

Lastly, connect the adaptor's AC line to an AC outlet on the amplifier. If there are not enough AC outlets on the amplifier, use a cube tap. In this way, the LM-35's power is automatically controlled by the amplifier.

After making the above connections, you can place the adaptor behind the tuner as in the following diagram, or near the tuner on another shelf if you wish. Notice that since the *combined* front-to-back dimensions of the tuner and adaptor is no greater than that of any Scott amplifier, sufficient cabinet space will be available without any cabinet modifications.

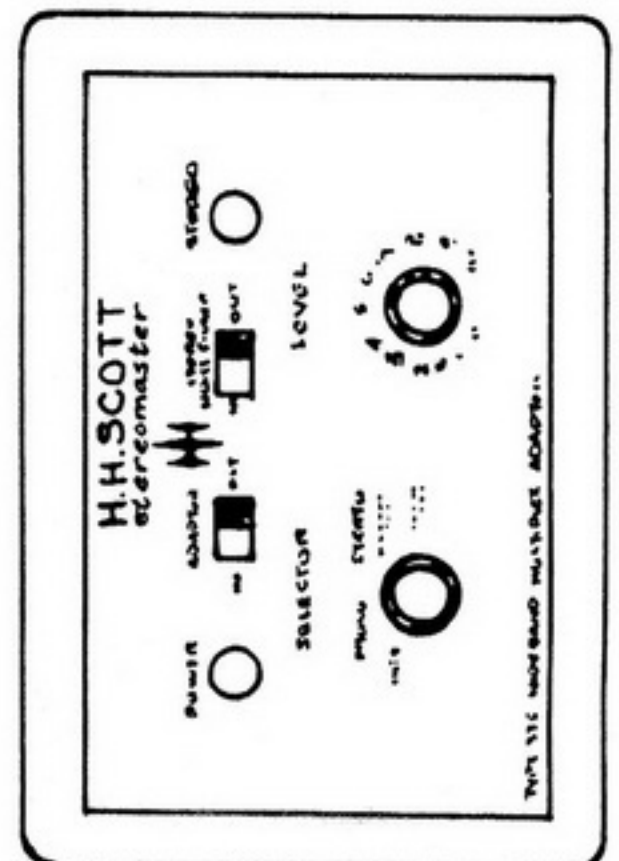
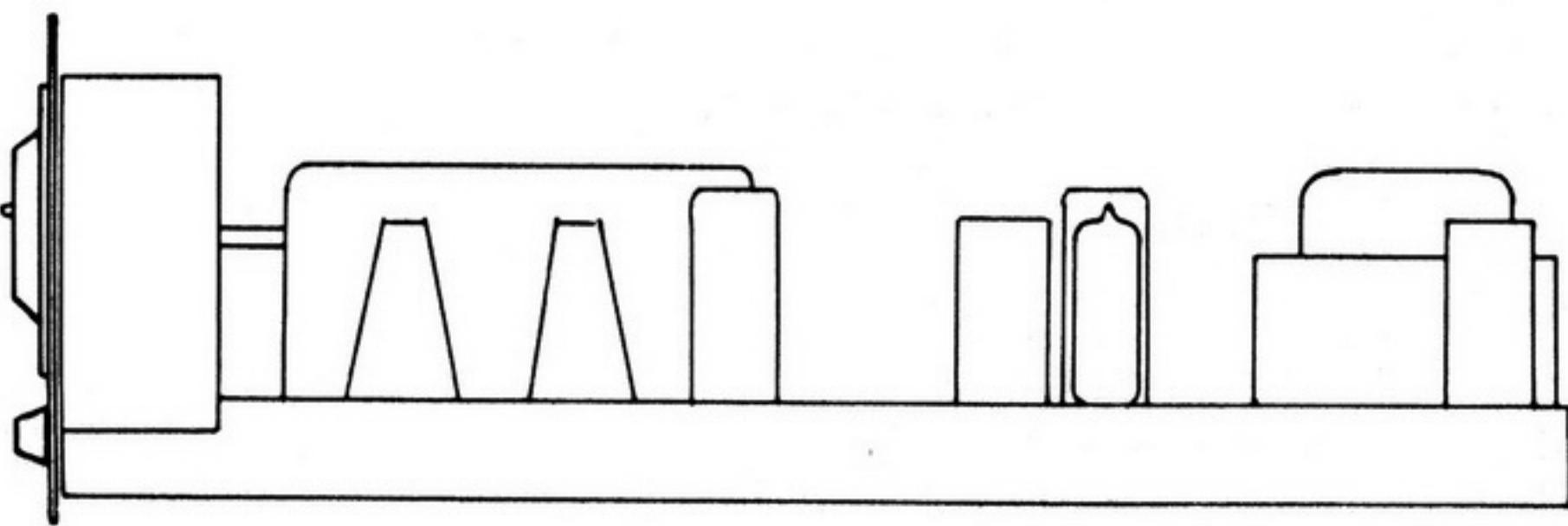
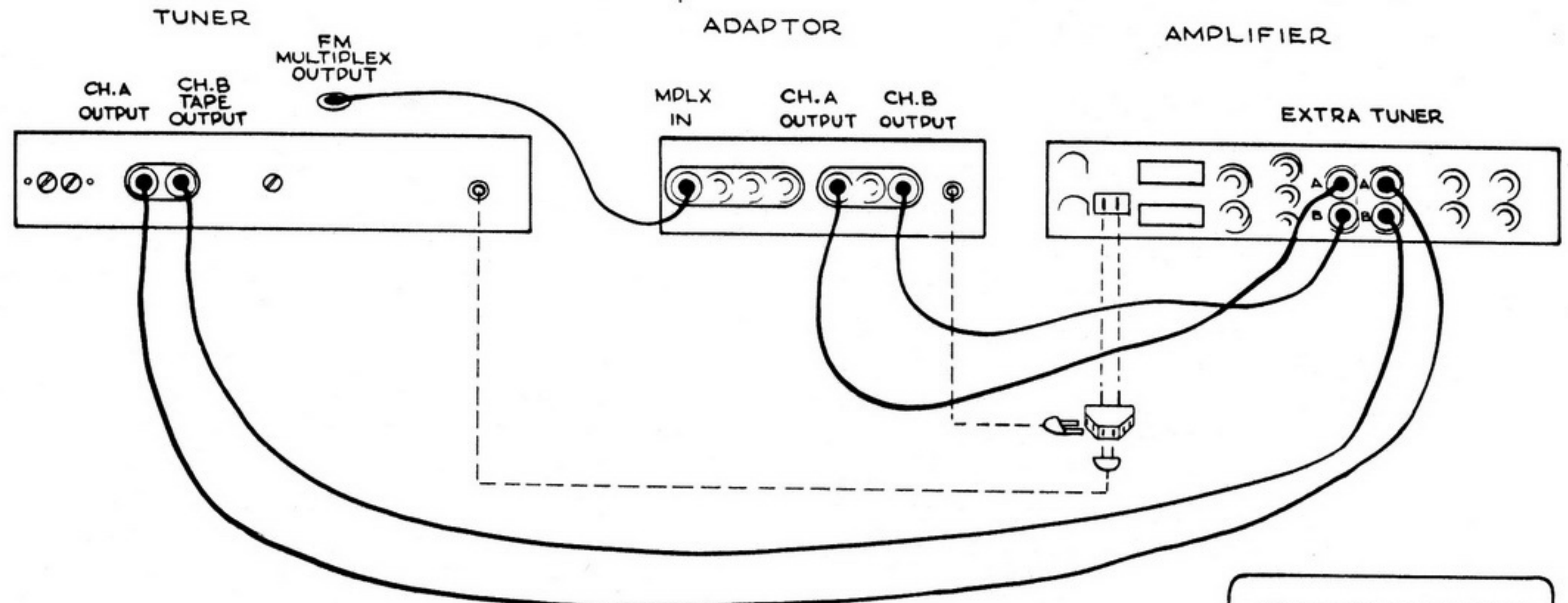

Separation

The Federal Communications Commission has ordered broadcasting stations to maintain at least 30 db. separation at the transmitter during multiplex stereo programs. What does this mean to you? Take an example: Suppose the station is broadcasting multiplex stereo and it just happens that the only sounds being picked up are on the right side. The station should transmit so that the only sound you hear comes from the right speaker. There should be no sound coming from your left speaker. In practice, it is impossible to have such separation. Some of the right channel signal is bound to sneak into the left channel, either at the transmitter or in your tuner. If the FCC specs are being met throughout, the amount of sound audible in the left speaker should be 30 db. lower in volume than the sound from the right speaker.

This is very difficult to accomplish. Most FM stations beginning to broadcast multiplex stereo take months of solid work before they obtain that much separation consistently. It is an enormous tribute to their abilities that most of them are eventually able to meet these strict standards. However, the 30 db. is only specified for the transmitter. If the station is using a phono cartridge with 15 db. of separation then you will only hear 15 db. of separation. Or if the station is using stereo records with limited separation, that is all you will hear, also.

Your Scott system is capable of as much separation as most stations provide and more. This is a function of both the FM tuner and the multiplex subassembly. The multiplex subassembly has been prealigned at the factory. If you have carefully followed directions and properly assembled your adaptor, it should match the tuner quite well. If for any reason it does not, then the separation provided by the complete system will not be as good as it might be. This is most rare so should not be of much concern.

However, if you are not getting good separation and you find that the problem is in the adaptor and not the broadcast (the only way to check is to try another multiplex adaptor under the same circumstances) there are two courses of action available. Assuming the tuner is working well monophonically, it is possible to readjust the multiplex section so that it more closely matches your particular FM tuner. This can either be done at the factory or by certain of our warranty stations with the necessary equipment (Write to the Kit Service Department for their names). It is also possible under certain conditions to make adjustments yourself. Read through this next section completely before undertaking anything.

SEPARATION ADJUSTMENT

Certain FM multiplex stations will occasionally broadcast test tones. At certain times of the day they will transmit over the right channel only or over the left channel only. Also, many stations make their spoken announcements over only one channel. Write to your FM station to see if they do either of these and at what time.

If they do, **AND ONLY IF THEY DO**, you may be able to improve the separation yourself. This is how to go about it:

1. Tune in the station and set all controls for optimum stereo reception.
2. Suppose the station is sending out a right channel signal, or their announcer is speaking on the right channel only. You should hear this loudly on the right speaker and quite faintly on the left speaker. (If the station is broadcasting left only this would be reversed.)
3. Adjust the amplifier so that you are only listening to the left speaker (or right as the case may be). If you have a Scott amplifier, this is done by rotating the **stereo balance** control to its maximum counterclockwise position. Turn up the volume so you can hear the weak sound more easily.
4. Take the tuning dial and rotate it very minutely in either direction until you have the exact point where the sound is faintest. This should be near the maximum indication point on the tuning indicator (it may be slightly off the exact maximum).
5. Look at the top of the multiplex section on the LM-35. **TOUCH NOTHING YET.**
6. Notice one little slotted pot, identified as "Sep". Observe carefully its position so that you can reset it exactly if necessary.
7. With the small screwdriver, rotate this in either direction till you find the spot where the sound from your left speaker is faintest. Stop right there and touch nothing else.
8. If there is no difference, return the pot to its original position. The difficulty was not with the tuner after all. Investigate elsewhere, or write to the Kit Service Dept.

Let us repeat — these adjustments are rarely necessary. (In careful checks of over 100 home built kits, only 5 needed even a slight adjustment.) In all other cases, the separation exceeded that of the program material being received.

LM-35 Parts List

HARDWARE AND MISC.

12	H-SMS-6x1/4 HW	Sheet Metal Screws
1	E-LT-AV-R	Solder Pack
1	E-LT-SD	Screwdriver
1	D-LK-10	Owner's Name Plate
2	KN-P-8	Knob
3	WAC-3A	Cable
1	Z-P-1	Parts Bag



SHEET METAL SCREW

MECHANICAL PARTS

1	Z-MX-4 Ass'y	Pre-assembled Multiplex Chassis
1	LM-35-M1-3	Main Chassis
1	LM-35-M2-2	Front Chassis
1	LM-35-M3-4	Bottom Cover
1	LM-35-M4-5	Control Shield
1	N-LM-35-1	Front Panel



CM
MICA
CAPACITOR



CC
CERAMIC
CAPACITOR

LM-35 PARTS LIST ELECTRICAL COMPONENTS

1	RC21-22K	Red/Red/Orange	1/2 Watt Resistor
2	RC21-330K	Orange/Orange/Yellow	1/2 Watt Resistor
2	RC21-470K	Yellow/Purple/Yellow	1/2 Watt Resistor
2	RC21-22M	Red/Red/Blue	1/2 Watt Resistor
2	RC31-470r	Yellow/Purple/Brown	1 Watt Resistor
1	RC31-1K	Brown/Black/Red	1 Watt Resistor
1	RW5-750		Wire Wound Resistor
1	CC-.001		Ceramic Capacitor
2	CM15-33		Mica Capacitor
1	CM15-220		Mica Capacitor
2	CM15-330		Mica Capacitor
1	V-SPL-NE-RF		Red Pilot Light
1	V-SPL-NE-YF		Yellow Pilot Light
1	V-6x4		Tube (V1)
1	V-12AT7		Tube (V505)
2	V-12AU7		Tube (V503, V504)
1	V-6BL8		Tube (V502)



RC
1 WATT RESISTOR

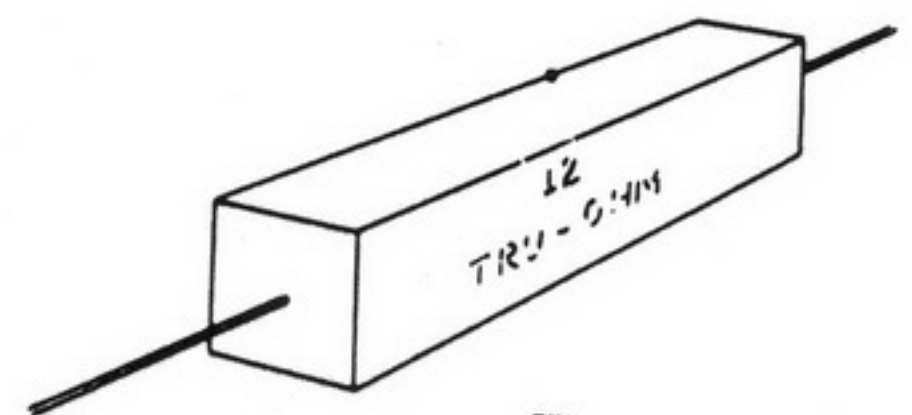

RW
WIRE WOUND RESISTOR

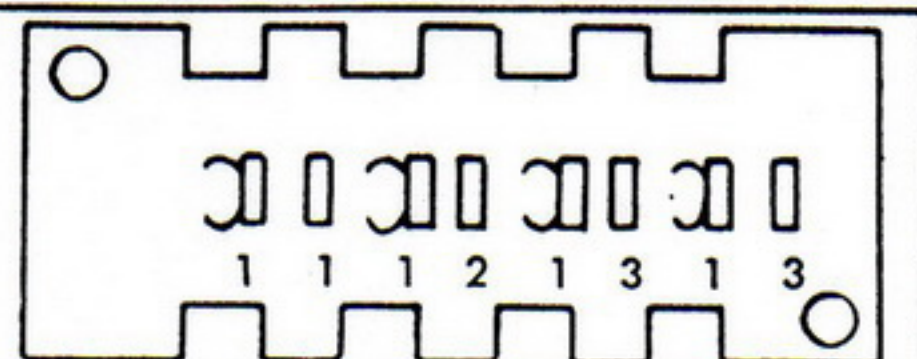
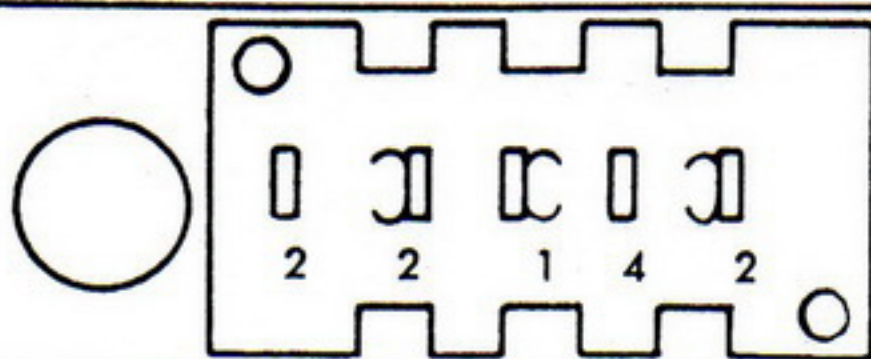
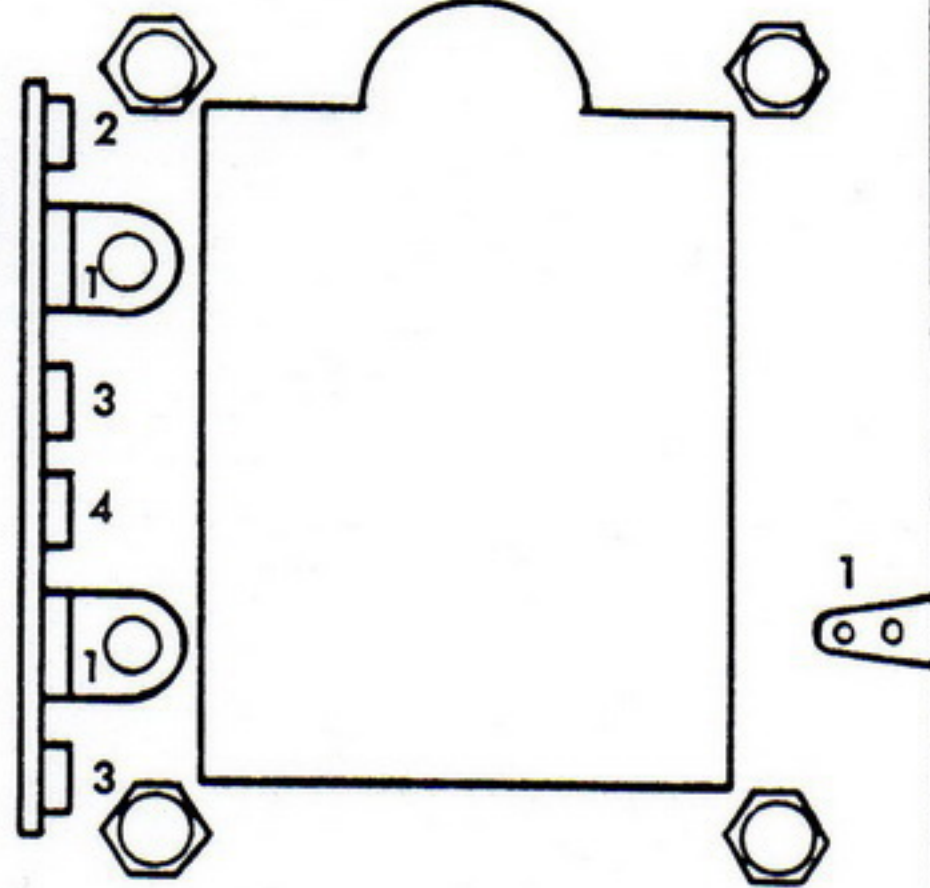
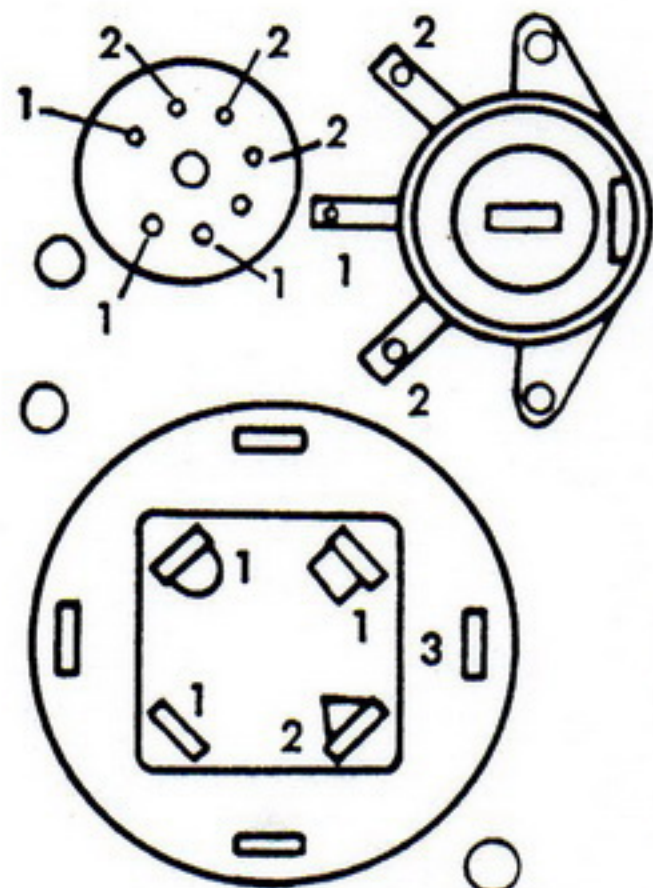
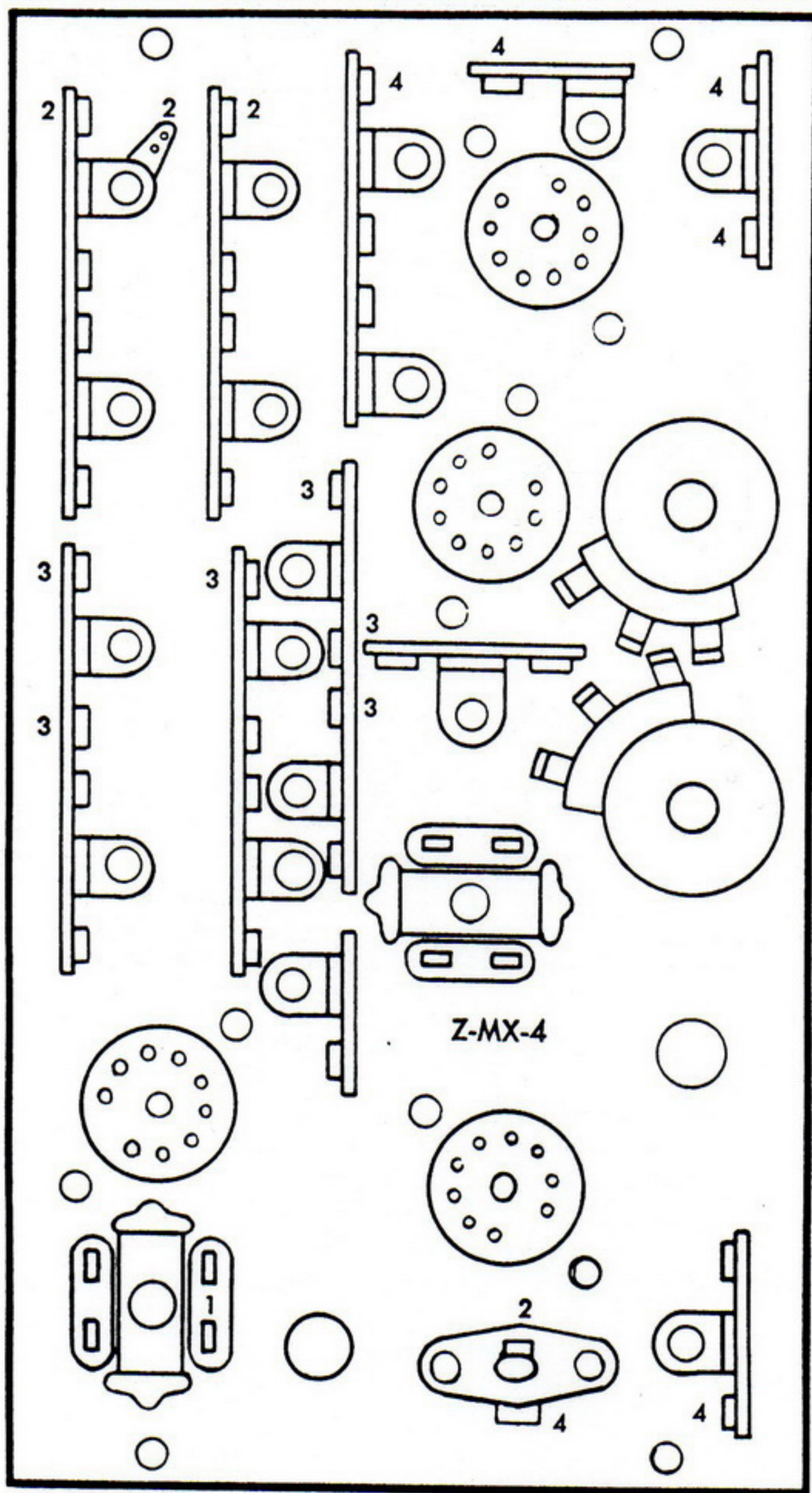

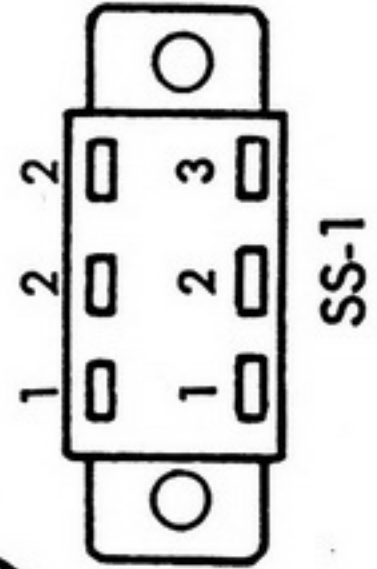
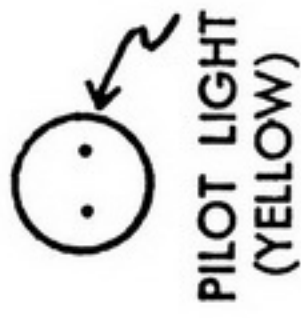
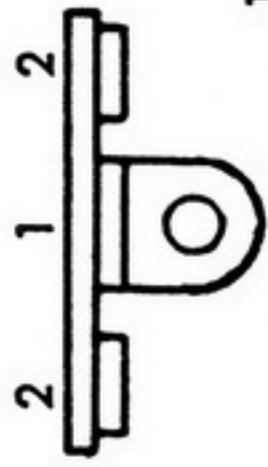

SS-1

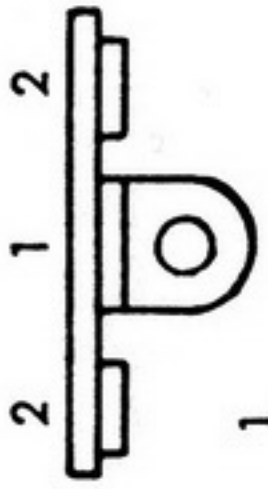

SS-2

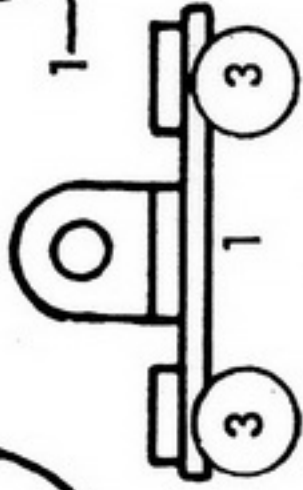
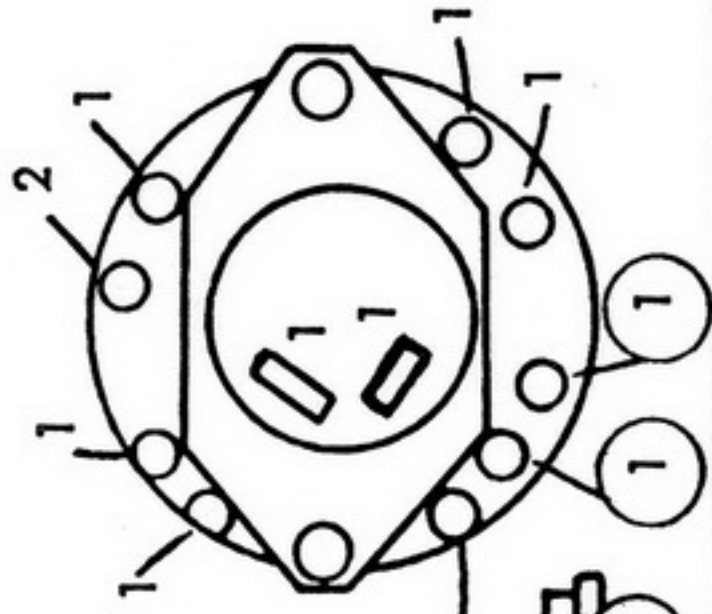
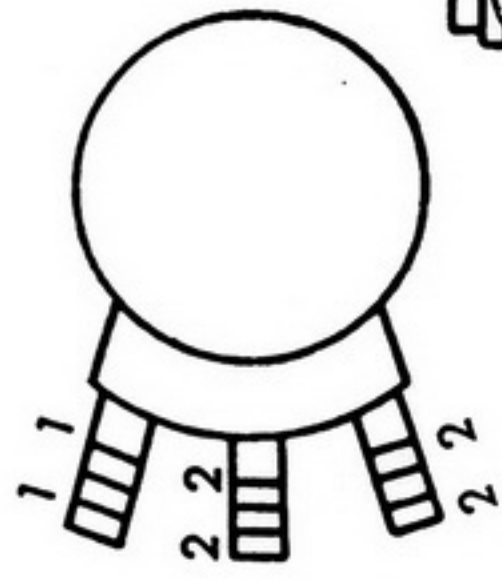
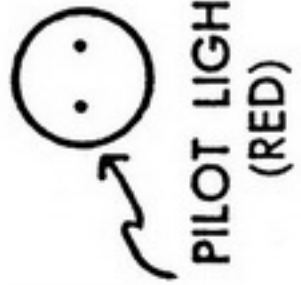

Choosing your Amplifier

Your new FM multiplex system is the finest on today's market. It is designed with the precision that has made the name H. H. Scott a synonym for quality in the component field.

But a fine high fidelity system is only as good as its weakest link. Therefore we suggest that you



LK-48 48-Watt Stereo Amplifier Kit

The price is the only modest thing about this new H. H. Scott Amplifier. In features . . . in power . . . and in performance it is one of the very best amplifiers available today. Scott's conservative design gives you full power, 24 watts (IHF) per channel from 20 to 20,000 cps. Features include: Separate bass and treble controls for each channel, derived center channel output, equalization for either tape heads or records, and complete tape monitoring switching facilities. Non-magnetic aluminum chassis and DC heated pre-amp tubes for inaudible hum.

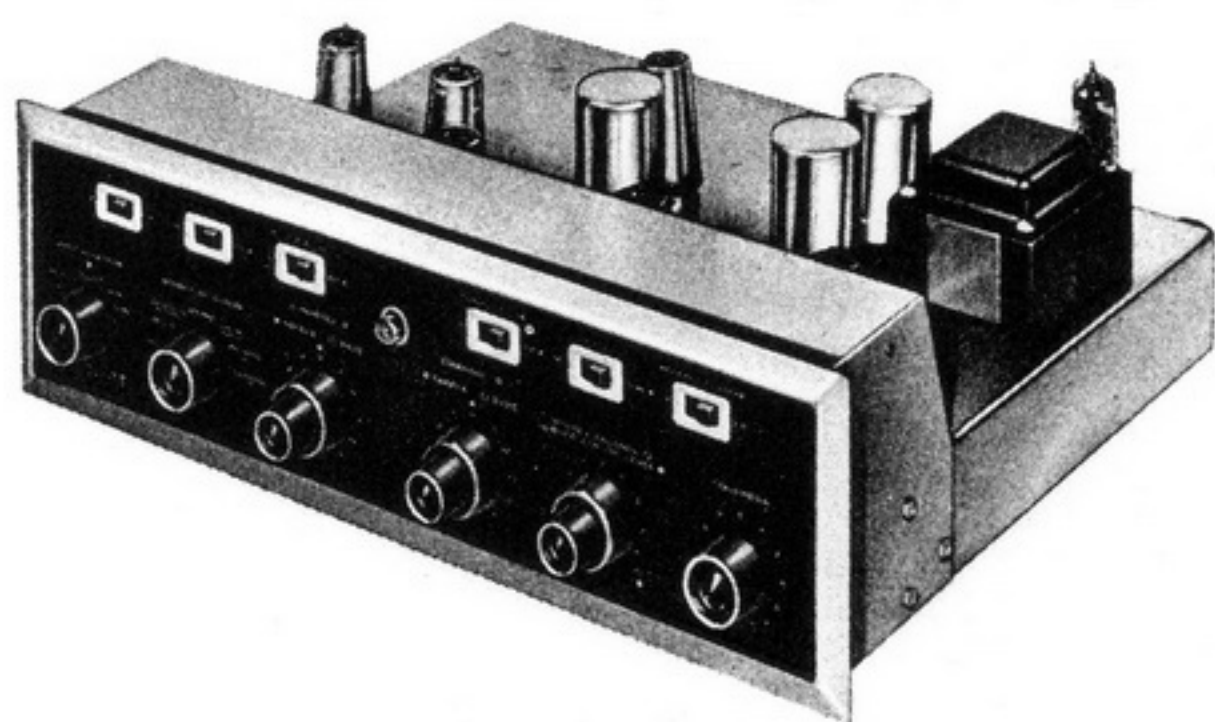

LC-21 Stereo Control Center Kit

New . . . but tried and true. Scott has been making fine preamplifiers for more than 14 years. Now you get the benefit of these many years of experience in a new Scott-kit that has everything! There are sixteen front-panel controls, five pairs of stereo inputs, derived center channel output and stereo tape recorder outputs. Non-magnetic aluminum chassis, DC operated tube heaters, and shielded power supply gives hum level of less than -80 db. Distortion is far below 0.1% at 2.5 volts output. Can be wired for home use, or for laboratory use where frequency response below 10 cps is required.

invest in an H. H. Scott stereo amplifier, kit or wired, when you are ready to expand your present system.

All H. H. Scott amplifiers are a perfect match both in appearance and performance. In particular you will enjoy assembling any of the following superb amplifier kits:



LK-72 80-Watt Stereo Amplifier Kit

The most powerful integrated amplifier kit on the market. Delivers a full 40 (IHF) watts per channel from 20 to 20,000 cps. This superb Scott kit has many features long associated only with expensive wired Scott units. 13 front panel controls include unique stereo balance circuitry, derived center channel level control and tape monitoring facilities. As Electronics World said (June '61) "like its predecessor (the LT-10) . . . no effort has been spared to make the building job simple, a lot of fun, and yet have the builder end up with a unit that looks and works like factory-built equipment."



LK-150 130-Watt Stereo Power Amplifier

We rate this magnificent power amplifier with typical Scott conservatism at 65 watts per channel (IHF). However, kit builders are finding that typical units actually deliver over 80 watts (IHF) at 20 cps . . . where power really counts! Famous 6550 matched-pair output tubes, rated at 100 watts are used. Unique output circuitry assures top performance without adjustment with external laboratory equipment. Total Harmonic Distortion less than 0.5% at full power. IM distortion less than 0.5% at full output. Amplifier absolutely stable even without load. 15" W x 6½" H x 11¼" D.

SERVICE BULLETINFORMODEL 335/LM-35 WIDEBAND MULTIPLEX ADAPTORGENERAL SERVICE NOTES

Service, other than replacement of either pilot lights or vacuum tubes is usually not required. If the adaptor is not operating properly, all external connections should be checked first. Generally, it is advisable to replace the adaptor with a similar device known to be working. The level control should be checked to insure that it is rotated away from its extreme counter-clockwise position. Then, the vacuum tubes should be checked by replacing them with new ones, one by one. The tubes should be tight in their sockets and provided with shields where applicable. Tube defects frequently do not show up in a tube tester. Only operation in the unit will insure the proper working of a vacuum tube. In replacing tubes, if possible, use exact replacement tubes, available from H. H. Scott or any authorized warranty service station. Other tubes will work, but only exact replacement tubes can give the full performance that the adaptor is capable of.

PRELIMINARY MULTIPLEX TESTS

Use a good Audio Oscillator. Connect adaptor to a Scott tuner as per instructions.

1. Connect the audio oscillator to the test point input on the multiplex section. Adjust the output of the oscillator for 0.25 volts. Set the controls as follows: level to maximum, selector to mono, filter to out, and AGC to mono.
2. Measure the output. It should be 2 to 3 volts with selector switch in either mono or stereo. With selector switch in mono adjust the balance pot (BAL) on the multiplex section so that the Channel A and B outputs are the same within 1 db.
3. Disable the multiplex section oscillator by grounding pin #2 of 12Au7 (V503). With the audio oscillator at 400 cps take a reference reading. It should be down maximum of 2 db at 20 cps., 2-4 db at 2 KC, 7-9 db at 5 KC, 12-14 db at 10 KC. Switch in the stereo noise filter and note additional 5-8 db drop. Switch the filter out and continue to 15 KC -- 15-18 db drop, a minimum of 21 db at 20 KC, and minimum of 44 db at 40 KC.
4. Turn selector switch to Stereo, subchannel filter out. Set oscillator to 67 KC, 0.25 volts output. Adjust L-502 for minimum output from either Channel A or B. The null is quite broad. If necessary increase output of audio oscillator for better null.

STEREO MULTIPLEX SEPARATION TESTS AND ADJUSTMENTS

Equipment needed: In addition to all the equipment mentioned before you will need a Hewlett-Packard 200CD Audio Oscillator or equivalent (with balanced output to ground -- oscillator with unbalanced outputs cannot be used), and the H. H. Scott Model 830 FM multiplex stereo generator.

Equipment set-up: Use the same arrangement described with the tuner alignment procedure, plus: Connect the Audio Oscillator to the 830 (as described in the 830 Instruction manual) and the 830 to the FM generator. Set the FM generator for External Modulation.

1. Set audio oscillator to 400 cps. and 830 for left channel (Channel A) signal only. **IMPORTANT:** The 830 MUST be carefully adjusted for input signal and output phase as described in the 830 Instruction Manual. The output phase must be monitored with a scope to check for variances. If the phase is off even slightly, your alignment will cause the tuner to have poor separation when tuned to station.
2. Set all controls on the adaptor for full stereo (level control to maximum, Selector switch to Stereo, subchannel filter out; stereo noise filter out; and AGC switch to Mono). Adjust the tuner to the point on the dial where you are transmitting your Channel A signal. Make sure you pick a point on the dial that does not coincide with a local FM station.
3. Adjust the tuning dial for maximum reading on the tuner's meter. Take a reference reading on the VTVM, db scale. Remove the output cable from Channel A output and insert it into Channel B output. The difference in output should exceed 30 db. Adjust the top of L-501 with a detector alignment tool for maximum separation. Then turn the pot marked "Sep" for maximum separation.
4. Readjust the 830 so it now provides a right channel signal only (Channel B). Repeat step 4, only the output of Channel A should be 30 db down, from Channel B. It often happens that a slight adjustment of BAL pot will increase separation slightly.
5. It is important to realize that maximum meter reading will not exactly coincide with maximum audio output (within 2 db) and maximum separation. However it comes extremely close to both and does give a good combination of separation, output, and low distortion.

EMERGENCY MULTIPLEX SEPARATION ADJUSTMENTS WITHOUT SPECIAL TEST EQUIPMENT

The following adjustments should only be attempted if it is impossible to get the proper multiplex test equipment and it is obvious that stereo separation is not satisfactory. The only way to be sure the adaptor is at fault is to substitute another adaptor, known to be working properly. (very often a unit will not appear to have good separation when actually the station or the program material is at fault).

The primary requirement is to have a local FM station broadcasting multiplex stereo with spoken announcements on one channel only. Most multiplex stations do provide this service at certain times of the day. Call the station and check. If they are among the few that are not broadcasting speech on one channel only, you might point out how valuable it would be to service people in their area if they did.

1. Assume the FM multiplex station is transmitting commercials on the right channel only (reverse everything if it is left only).
2. Connect an audio cable from Channel A output to an amplifier and a speaker.
3. Tune in the station carefully using the tuning meter. Set the Selector to Stereo, Sub-channel filter out; Stereo Noise Filter to Out; ACG to Mono; Level to maximum.
4. When the announcer begins to talk, he should be barely audible in Channel A or the left channel signal. Carefully retune till you find the point where the sound is faintest (you should be quite close to the maximum meter reading position.)
5. Carefully rotate the "Sep" pot on the multiplex adaptor until the voice is at its faintest. Keep the volume up on the amplifier.
6. If this does not provide sufficient improvement, take the detector alignment tool and insert it into the top of L-501. Rotate slowly for the best separation point. Then readjust the "Sep" pot.
7. If this does not help, the difficulty may be with the station or with some other part of the system. For more information, write to:

Technical Services Dept.
H. H. Scott, Inc.
111 Powder Mill Road
Maynard, Massachusetts

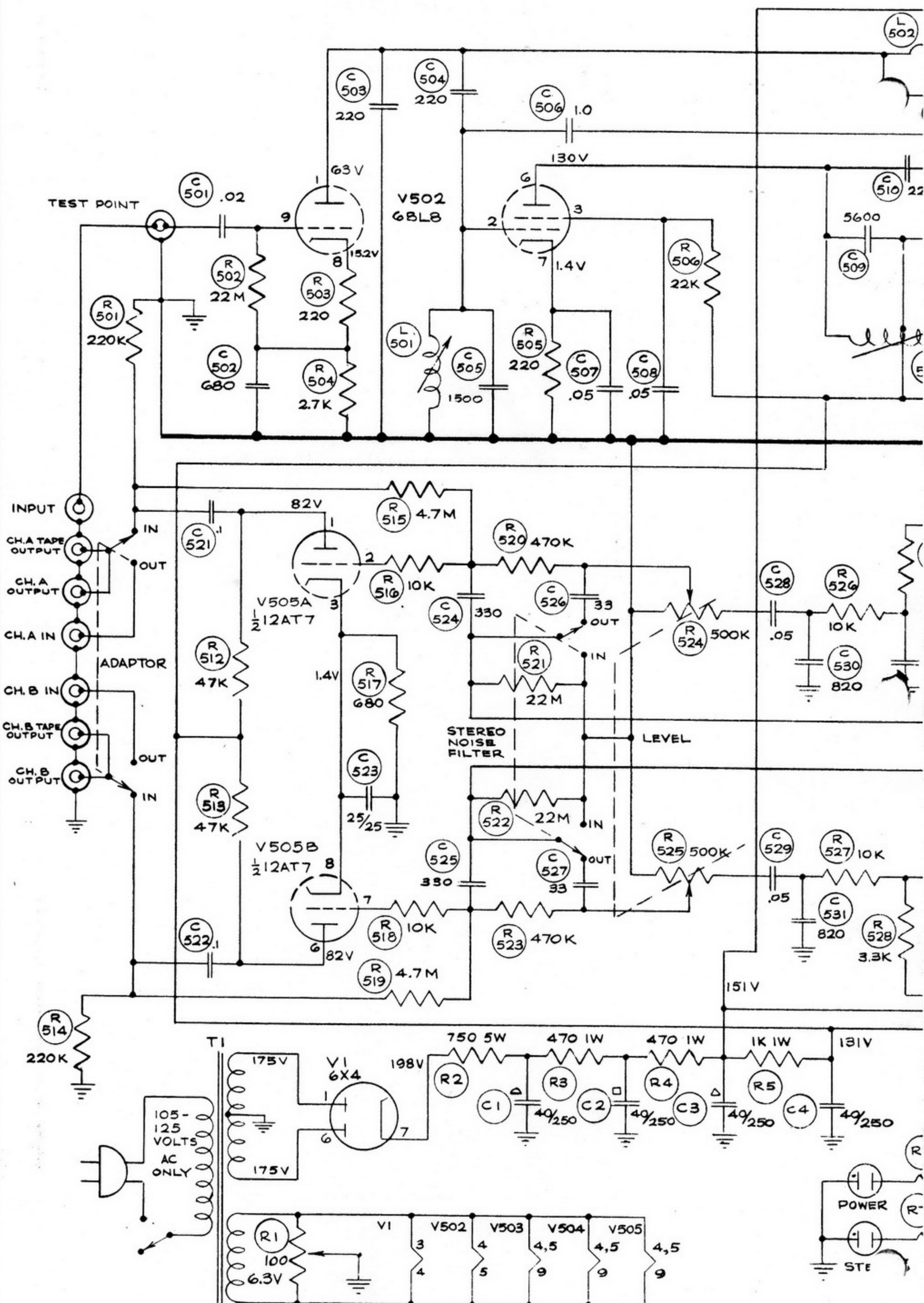

TYPE 335 WID
LM-35 WIDEBA

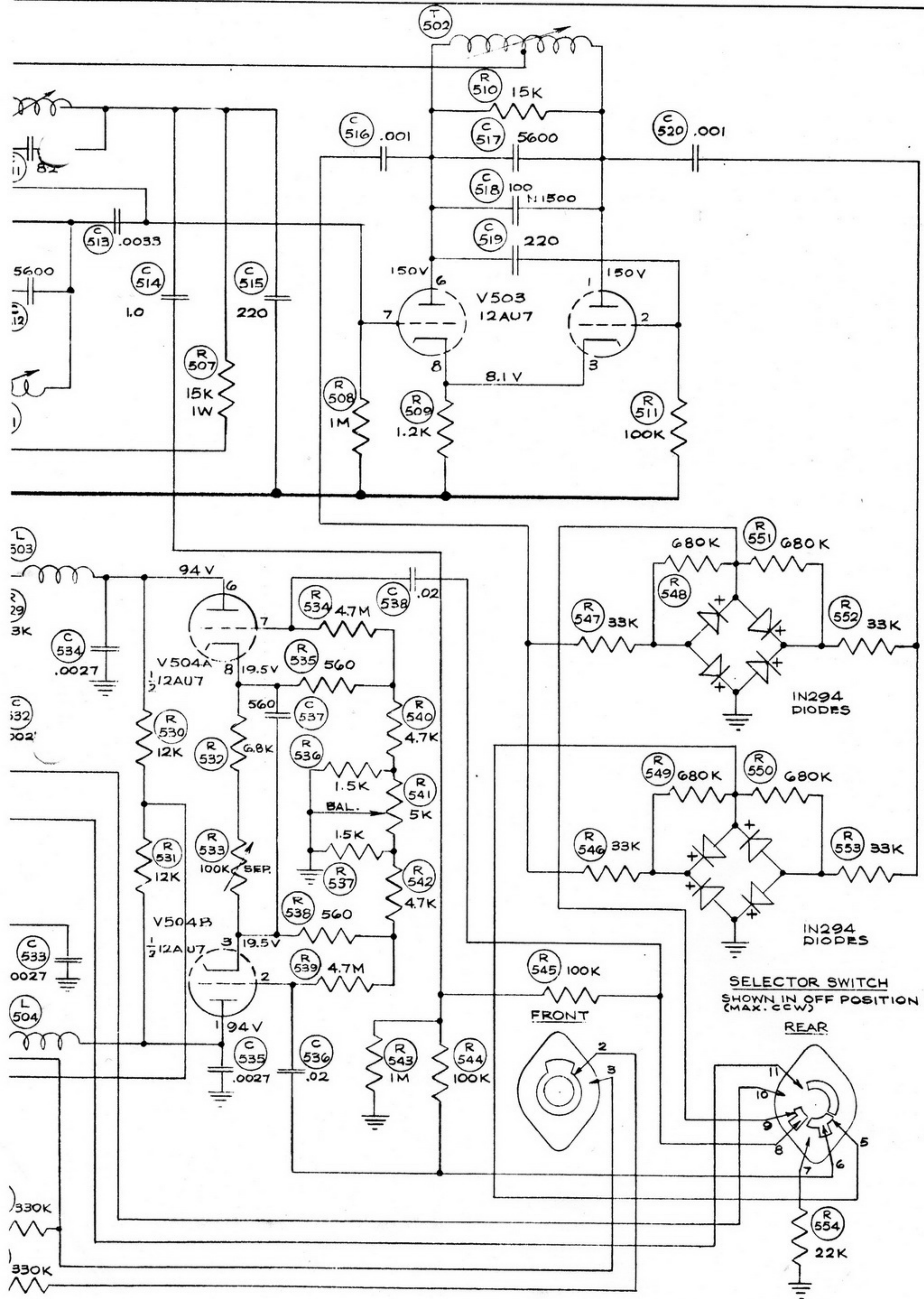

VOLTAGES MEASURED AT 117V LINE WITH VTVM.

WIDE BAND MULTIPLEX ADAPTOR &
NARROW BAND MULTIPLEX ADAPTOR KIT.

	SCALE: ~	CIRCUIT DIAGRAM	5/24/61
	H. H. SCOTT, INC. MAYNARD, MASS., U. S. A.		
DR. W.C., D.R.	ENG. DFM	DWG. NUMBER C-335-C1 SUB. 0	
CH.	PROD.		

MPX ASSY. TOP VIEW

