

**THE
FISHER®**



StrataKit

ASSEMBLY MANUAL

KX-100
50-WATT
STEREO CONTROL
AMPLIFIER



AVERY FISHER
*Founder and President
Fisher Radio Corporation*

A Message From Avery Fisher

It is now almost twenty-seven years since we made and delivered our first instrument for high fidelity reproduction of radio and records. (That instrument is now in the Smithsonian Institution, Washington, D. C.) Beginning with that first unit it has been our unflinching policy to manufacture only the very best of equipment, and to make that equipment available to the widest possible audience.

It is with great pleasure that we are now able to furnish Fisher equipment in kit form, thus bringing instruments of Fisher quality within the reach of a wide, new audience.

The kit you have just purchased represents the efforts of the finest single group of engineers in the high fidelity industry. Our entire approach to the problem of designing a kit was based on two simple rules. The first was that the quality must in every particular be on a complete par with the finest comparable Fisher equipment, as built in our own Production Department. The second was that the method of assembly must be so thoroughly simplified and organized that even the most unskilled purchaser could expect a perfect end result. No effort has been spared to achieve these two objectives and I know that the building of this kit will bring you a sense of accomplishment based on the pleasure of creating something fine, and on the knowledge that here is an investment that will bring virtually unnumbered years of musical enjoyment to you and your family.

Technical Specifications

Music Power Output (0.5% total harmonic distortion at 1 kc, channels driven simultaneously, IHFM)	50 watts (both channels)
RMS Power (0.5% total harmonic distortion at 1 kc, channels driven separately)	24 watts (each channel)
RMS Power (1.0% IM distortion, SMPTE, channels driven simultaneously)	45 watts (both channels)
Hum and noise (below RMS rated output)	
Low level inputs (6 mv reference)	65 db
High level inputs (450 mv reference)	80 db
Volume control at minimum	88 db
Sensitivity (for 24 watts RMS per channel)	
TAPE HEAD (1 kc)	2 mv
PHONO (1 kc)	
High level	16 mv
Low level	3.5 mv
High level (AUX, TUNER)	300 mv
Frequency Response	
Power amplifier section	10-75,000 cps, ± 1 db
Over-all	20-20,000 cps, ± 1 db
Bass Control	22 db total variation at 50 cps
Treble Control	20 db total variation at 10 Kc
Stereo Separation (at 1 kc)	better than 55 db
High Filter	-3 db at 5.5 kc Slope: 12 db/octave
Subsonic Filter	-1 db at 19 cps -20 db at 5 cps



THE FISHER KX-100 STEREOPHONIC Master Control-Amplifier

Now It's Fun To Build A Kit!

But before you start... Please read this page carefully... It isn't very long!

Building a FISHER STRATAKIT is a pleasure — not a chore. We enjoyed designing it and writing this assembly manual, and as you read on, you will find this reflected in our instructions. We hope you did not expect stiff and formal, “college thesis” prose — you won't get it! And if you think we're too flippant, please bear with us — loosen up... enjoy yourself... that's the purpose of a kit!

What is required to build a kit? The desire of course, a little mechanical skill, the ability to solder, but most important...

Patience

We know you're anxious to get started, get finished, and try it out. But please — read the instructions carefully — examine the illustrations closely, and you will have no trouble.

Speaking of trouble, do you know that over 90% of the difficulty encountered by kit builders is due to *one* cause? Indeed it is — and what do you think this trouble-maker is?

Defective parts... nope.

Wiring errors?... surprisingly not.

Errors in the instructions... Please!

Turn the page and find out.

Soldering

That's right — poorly soldered connections cause well over 90% of kit trouble. (If the foregoing sentence did not make sense to you, you must have failed to read the previous page. Better go back and read it now carefully.)

Soldering is a simple process, but remember . . .

Solder is not glue . . .

. . . that must be melted before it is used. Soldering is a molecular process and in order for it to take place, certain conditions *must* be met.

The parts to be soldered must be heated to a temperature hot enough to melt the solder. In other words, the soldering iron is not to be used to melt the solder — as shown in FIGURE 1.

Note that the soldering iron tip is held against the “joint” until the joint is hot enough to melt the solder. Then the solder is pressed against the joint until it melts and flows around the joint. Finally, the iron is removed and the melted solder cools and hardens.

The soldered joint must not be disturbed until the melted solder hardens. If the soldered joint is disturbed prematurely, you will have to resolder it. Normally this can be done just by holding the iron on the joint until the solder melts again, without adding more solder. At this point an obvious question is . . . HOW MUCH SOLDER . . . is needed for a properly soldered connection? The answer — not much! Use *only enough* solder to coat the parts to be soldered together.

The parts to be soldered together must be perfectly clean. Obviously we cannot scrub the parts — instead, we use a “rosin” flux as a cleaning agent and the rosin, in paste form, is right in the center core of the solder supplied with the kit.

When this “rosin-core” solder is brought into contact with heated parts the rosin paste melts before the solder and coats the parts. Thus where we only had a “dirty joint” we now have a dirty joint covered with rosin! But wait! The heat vaporizes the rosin and, like a sponge, it picks up all the dirt and grime on the joint, and carries it off into the air! Unfortunately, the melted rosin covering the joint will act as an insulator just as the dirt did. That is why sufficient heat must be ap-

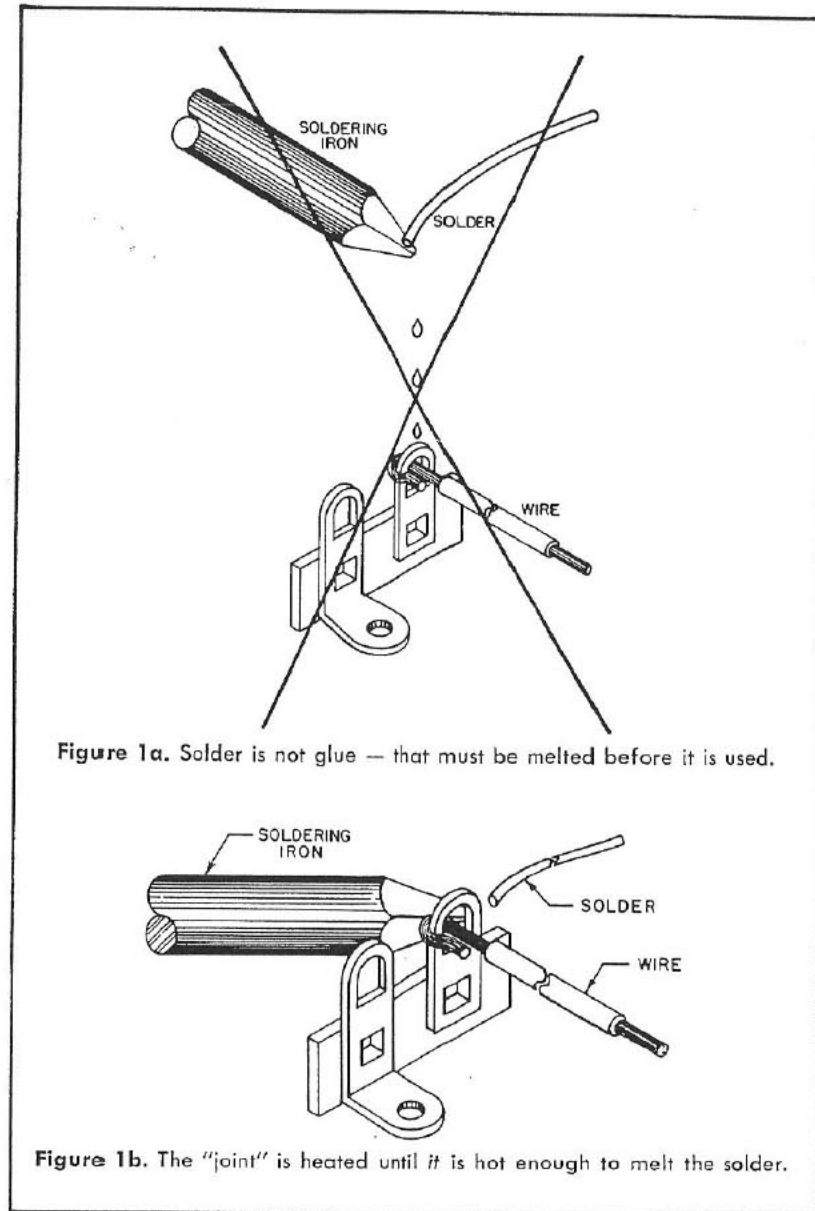

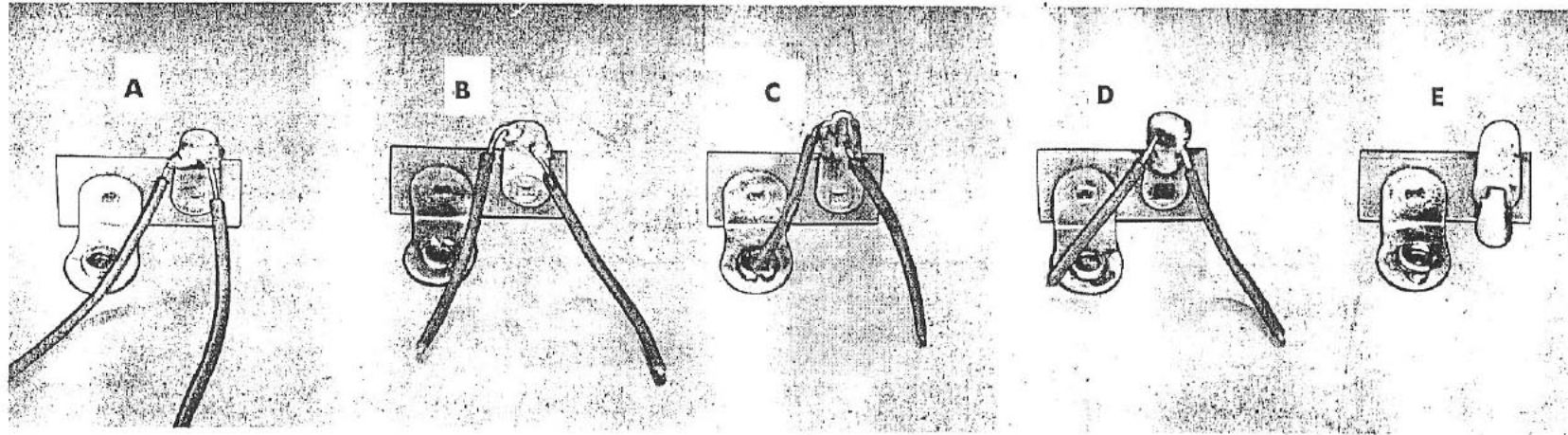

Figure 2. Examples of soldered joints: (a) good; (b) not enough solder; (c) moved before "set"; (d) too much solder; (e) short caused by too much solder.

plied to vaporize most of the rosin. More improperly soldered connections are due to insufficient heat than all other causes combined. This is so important that we must repeat it . . .

Sufficient heat must be applied to vaporize the rosin.

Use only rosin core solder; do not use additional flux or pastes.

The rosin flux is a necessary evil — we need it to clean the parts but then we have to boil it away.

Never add more — if more were needed the solder manufacturers would include it in the solder. You have been supplied more than enough solder to build your amplifier. However, if you do run out, make certain that you buy "rosin-core solder" only. Sometimes it is marked "radio rosin-core."

If You Use Acid Core Solder All Warranties Will Be Void and We Will Be Unable to Repair the Unit

The soldering iron tip must be tinned and wiped clean at all times.

No matter what type of iron you use the tip must be "tinned," that is, coated with solder. Despite the tinning, though, the tip blackens and must be continually wiped clean. Obtain an old piece of cotton cloth about one foot square, fold it up and keep it next to your soldering iron for this purpose.

As a summary refer to FIGURE 2. And don't forget . . .

Poor soldering causes over 90% of kit troubles . . . and insufficient heat and too much solder cause most poor soldering.

Tools . . . What do you need?

Very few tools are required to construct your FISHER STRATAKIT — you may already have them. Here is what you need:

- A pair of long nose pliers
- A pair of wirecutters
- A pair of combination pliers
- A 6 to 10-inch-length screwdriver
- A soldering iron

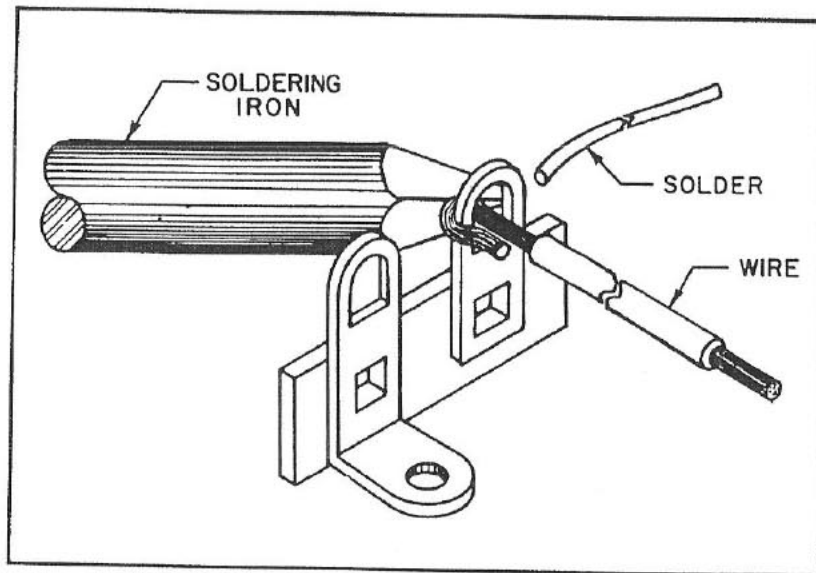

Figure 3. Connecting wires to lugs — just insert the wire in the lug, bend it over, and solder.

We suggest you use a pencil-type soldering iron such as the Ungar, with a $47\frac{1}{2}$ watt tip. If you have a bench type iron with a 60 to 100 watt element it will be perfectly all right provided the tip diameter is no greater than $\frac{3}{8}$ inch. A soldering gun is designed for repair work and is not recommended for kit construction.

Construction

Most of the parts in your FISHER STRATAKIT have built-in terminals, or lugs, such as the controls and the switches. The others — resistors, capacitors, etc., have wire leads. In order to “form” electronic circuits you will simply connect these parts together. When the leads are not long enough wires are used; and to form a rigid assembly, these components and wires are connected to lugs on terminal strips as shown in FIGURE 3.

Dressing

We don't mean clothing or stuffing, but, rather, lead-dressing — the

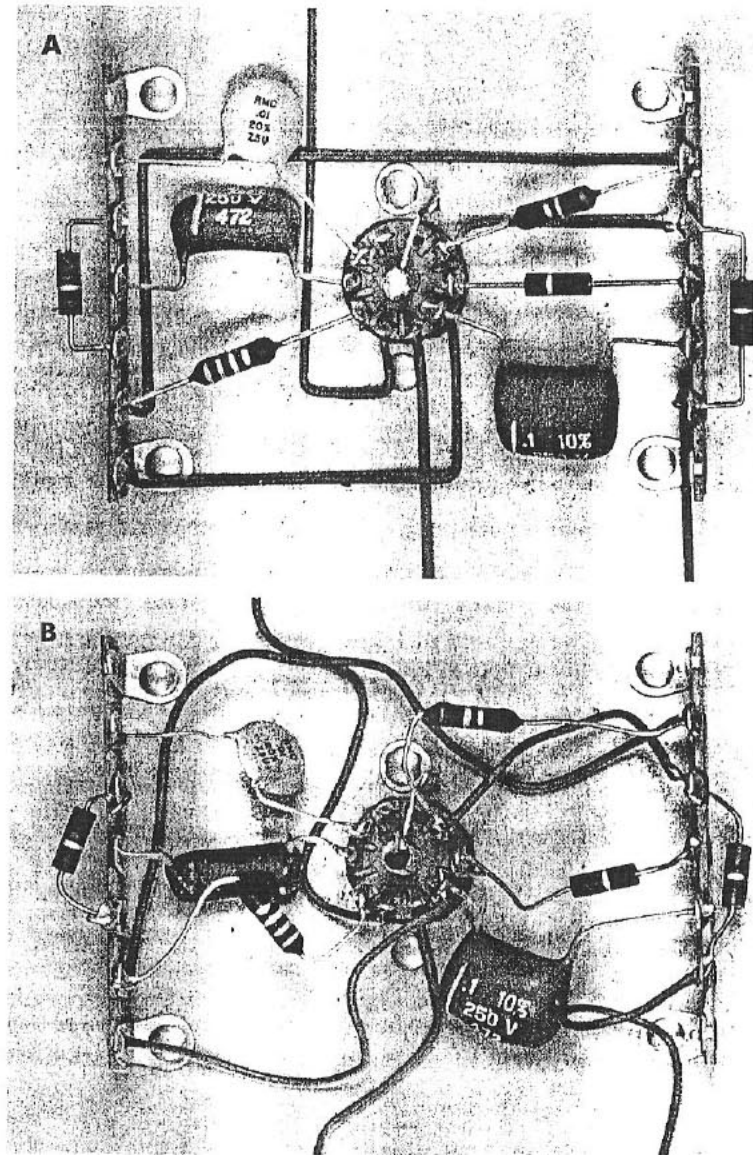

Figure 4. The right way 4 (a); and the wrong way 4 (b). Besides looking neater the assembly in 4 (a) is less apt to cause trouble.

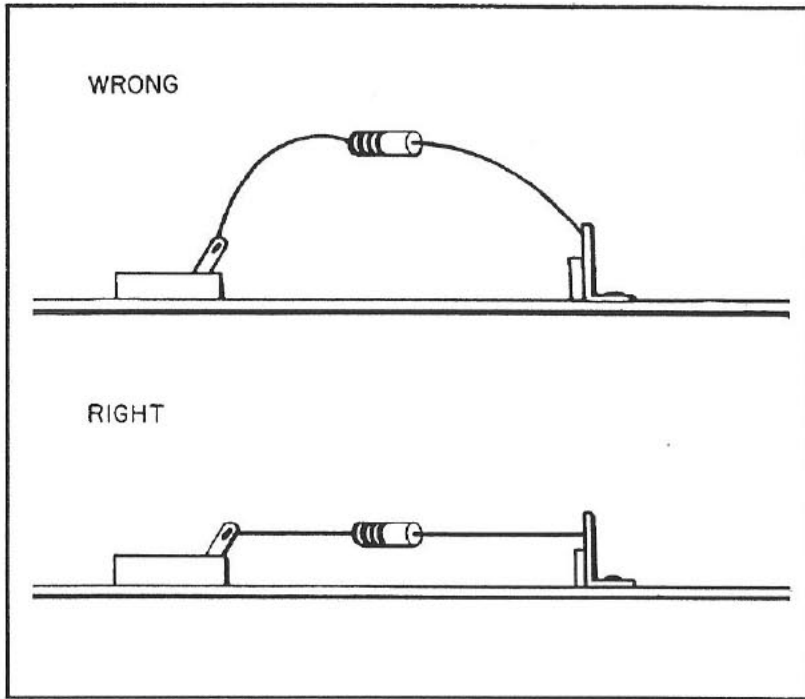

Figure 5. Watch your "vertical," tool

proper placement of leads, wires, and components, as shown in FIGURE 4. Both of these photos show the same electrical circuit using the same wire length. However, in FIGURE 4B, the resistor and capacitor leads have not been cut properly. Equally important — the wires are not positioned properly. So, when you wire — be neat. The component leads must be cut as directed; the components and wires must be positioned exactly as illustrated.

It is also possible to have "altitude trouble." In view of the fact that you are wiring in three dimensions, it is equally important that the wires and parts be properly positioned in respect to *height*, as shown in FIGURE 5. Normally all wires will be "dressed" down along the chassis while the resistors and capacitors are positioned as illustrated.

Let us look at some of the components you will use.

Resistors:

The resistors you will use in your FISHER STRATAKIT are identified in two ways. Those rated at under $\frac{1}{2}$ watt (the power the resistor can safely handle) are color-coded by bands of color. The color-code is given on the parts list in the FISHER STRATAPACK as well as in the instructions when you install the part.

However, you must read the colors in the correct order. Note, in FIGURE 6, that the colors are read from the end of the resistor where the colors start (the other end has only the body color.) The fourth color band indicates the tolerance of the resistor. Unless otherwise noted, this band can be ignored. Wherever close-tolerance resistors are desirable, they have been supplied.

Note that the "multiplier" in the chart actually indicates the number of zeros in the resistor value. A 220 ohm resistor, for example, would be red, red, brown while a 22,000 ohm resistor would be red, red, orange.

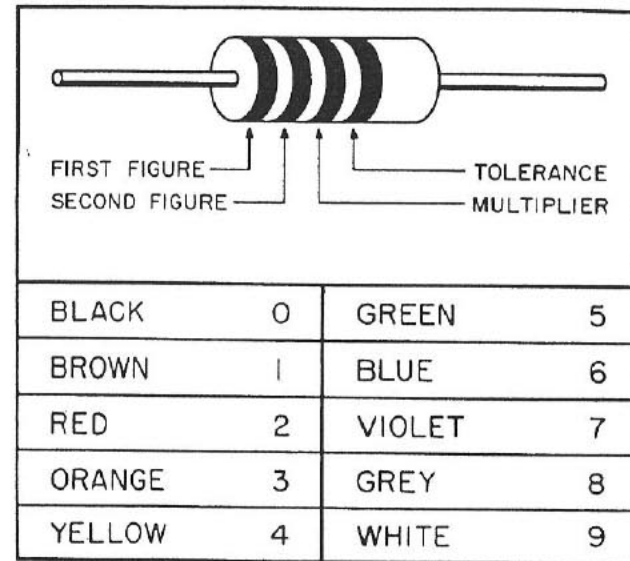

Figure 6. Resistor color-code.

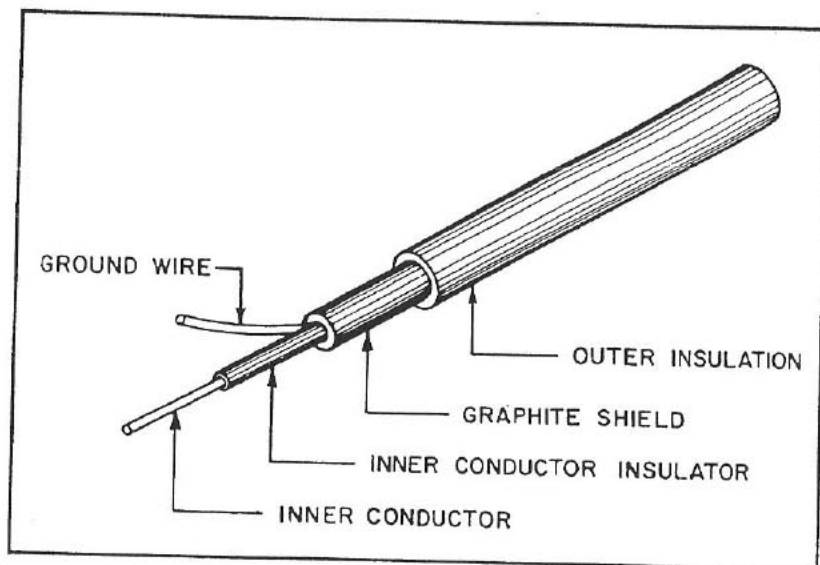

Figure 7. Shielded cable.

Shielded Cable

In some of the circuits it is necessary to shield the signals from outside interference by using a wire inside another wire. This "outer" wire is "grounded," so that any hum or noise it picks up is siphoned away from the signal in the inner wire.

The shielded cable supplied with the STRATAKIT consists of five sections, as shown in FIGURE 7. This cable has been cut to the proper length and the outer insulation has been stripped off, exposing the ground wire and the inner insulated (signal carrying wire.) To use it you will need to strip off the insulation covering the inner wire.

No doubt the easiest way to do this is to purchase a small pair of wire-strippers (generally sold for under \$1.00). Another method is to hold the insulated inner conductor about $\frac{3}{8}$ -inch back from the end with your combination pliers, grasp the wire right next to the pliers with the tips of your long nose pliers, and pull off the insulation. You can also lightly score the insulation with a knife blade, but be sure not to cut too deeply or you'll nick the wire and cause it to break off.

Silicon Diodes

These diodes replace the vacuum tube rectifiers, used in most amplifiers, to improve the power output, stability, and trouble-free operation of your StrataKit.

Despite the fact that these diodes are electrically very rugged (they far out-last tubes) they are sensitive to heat. Serious damage can occur by touching the hot soldering iron on the diode itself or even by holding the iron too long on the leads when soldering them into place. Of course if you don't hold the iron long enough on the joint you'll end up with a rosin joint!

So there you are!

But there is a solution. Before soldering them in place it is best to re-tin the ends of the leads. Hold the silicon diode with your long nose pliers between the diode body and the end of the lead which you will tin. You can now bring the diode lead, solder, and soldering iron together to re-tin the lead end. Holding the pliers between the diode and the hot soldering iron permits the pliers to absorb the heat which would otherwise be passed on to the diode.

Oops! Made A Mistake?

Naturally it is not likely, but there is just the slightest possibility that you may slip — by cutting resistor or capacitor leads too short, breaking a piece of hook-up wire or shielded cable, or breaking off a terminal strip or tube socket lug.

If you break or accidentally cut a resistor or capacitor lead too short, all you need do is extend it with a piece of bare wire.

Should you break one of the lengths of pre-cut, pre-stripped wire or cable you can simply make your own. We have supplied a small roll of wire and cable for this purpose — measure it, cut it, strip it, and you are back in business. Of course it may not be the color of the original but that does not matter. If you break off a terminal strip or tube socket lug, it is necessary to drill out the rivet(s) using a No. 30 (.128") drill. After removing the rivet(s) a new part can be installed with ordinary $\frac{1}{4}$ -inch 4-40 machine screws, 4-40 hex nuts, and No. 4 lock-washers.

If you need any replacement parts, or in fact if you have *any* problem, write us immediately. Most of the components can be identified by the parts list at the end of the assembly manual. Be sure to give the FISHER part number as well as the electrical value and description of the item. The terminal strips can be identified inasmuch as they are shown in the assembly illustrations.

"STOP"

Have you read the preceding pages? If not, please go back and do so, *even* if you have built many kits. We believe you will find them enjoyable and rewarding. Reading time — only 9 minutes.

Preliminary Instructions

The assembly instructions for your KX-100 StrataKit are organized in sections, called stages. Each stage includes a separate StrataPack plastic packet that contains all of the parts you will need for the stage. Therefore, when you finish each stage, you will have used all of the parts — an automatic check on what you have completed!

When the parts you need are not in the numbered StrataPacks, they will be found in the "parts box" or in the extra StrataPacks. Notice that a Spare Parts StrataPack is provided with extra hardware and wire.

Each stage of wiring requires an illustration. In most cases the illustration will be on the page facing the text. Some stages require a larger figure — these you will find on separate sheet.

Examine the separate illustrations, particularly Figures 8, 9, and 10. Figures 8 and 9 are over-all views of the chassis and front panel identifying all of the terminals. You can use them throughout construction to quickly identify and locate lugs. In addition, you will note that both contain a chart showing the "color-code" used in the Figures and a handy scale to measure resistor and capacitor leads. If you wish, pin or tape Figures 8 and 9 in front of your work area.

Figure 10 is a photograph of the chassis wiring and Figure 11 is a photo showing the complete front panel wiring before the panel is attached to the chassis. You'll find both useful throughout the assembly of your Fisher KX-100 StrataKit.

Disassembly Instructions

The parts in the left-hand section of the carton will be needed first. As shown, slit all four corners of this section with a knife and bend out the three free sides.

Remove the acetate cover over the StrataPacks and lift them out. When you require the other parts be sure to remove them carefully — cut the cardboard instead of "forcing" them out.

Pull the knobs from the control shafts and put them in the Spare Parts StrataPack. With your combination pliers, remove the large hex nuts on the Mode and Balance control shafts — be careful not to scratch the dress panel.

Remove the dress panel and set it aside. It is a good idea to wrap it in a soft cloth for protection.

Next, remove the front panel shield from the chassis — see page 65. Finally, turn over the chassis and remove the bottom cover. Put all the screws in the Spare Parts StrataPack.

There is no need to disassemble the right-hand section of the carton yet. When you do need the parts, follow the same procedure as above.

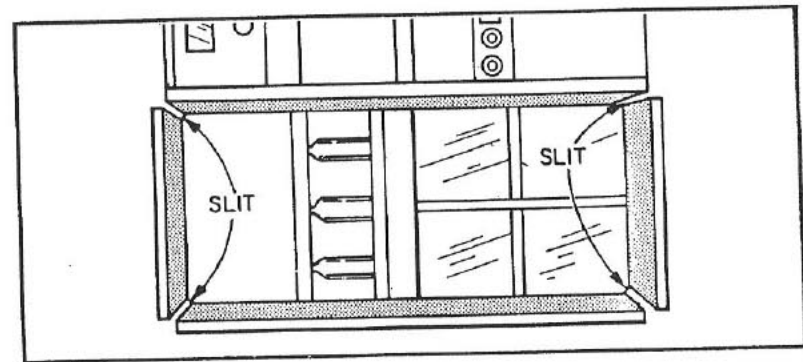

This Kit has been approved by the Canadian Standards Association for minimum electrical safety requirements provided it is assembled and wired in accordance with the instructions.

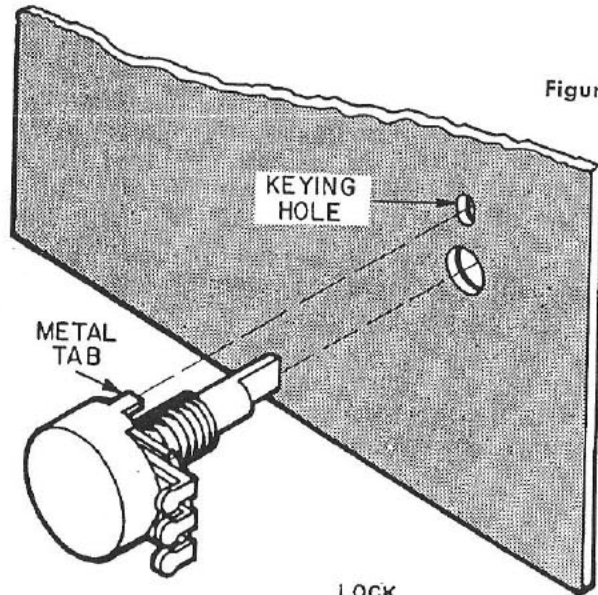

Figure 1-1

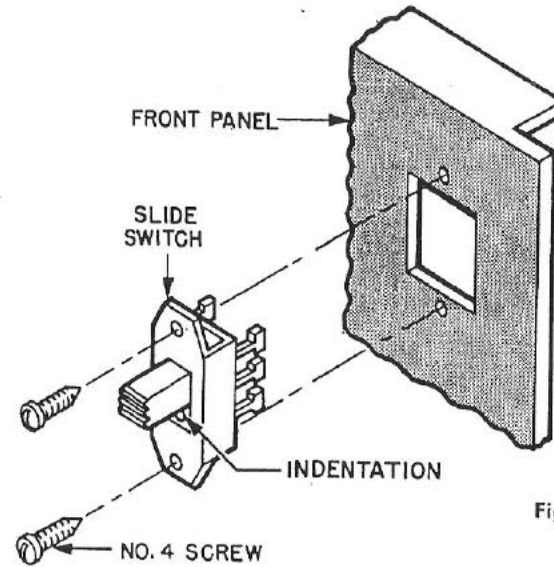

Figure 1-2

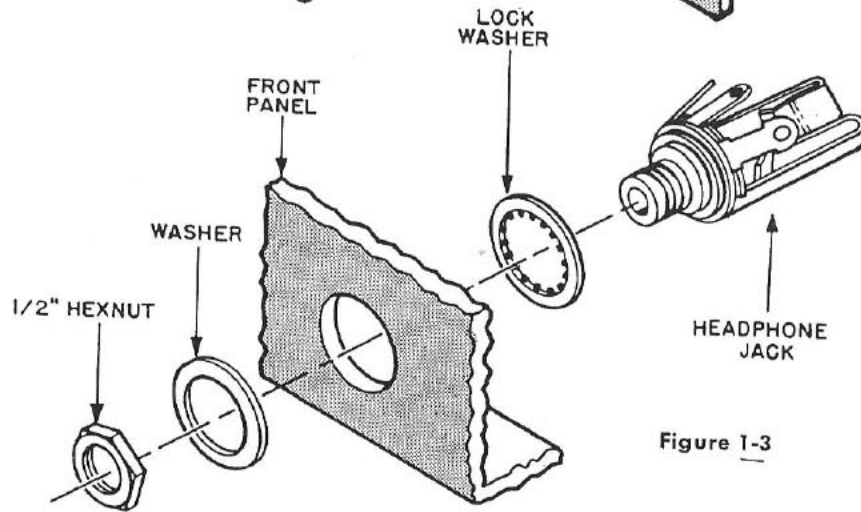

Figure 1-3

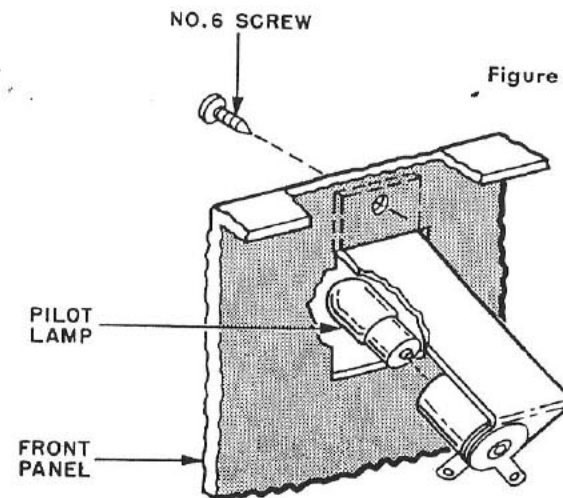

Figure 1-4

STAGE 1

AFTER YOU COMPLETE EACH STEP, check the appropriate box so you'll know where to begin if you are interrupted or stop working. By the way, you may notice in both the step and terminal identification that we skipped the letters I (eye) and O (oh) to prevent possible confusion with the numbers 1 (one) and 0 (Zero).

Locate StrataPack 1, Fig. 8 on the fold-out sheet, and the front panel. Refer to Fig. 8, the over-all view of the front panel, to locate the section of the panel on which you're working. These sections are illustrated individually right in the assembly book.

The front panel has been attached to the chassis to prevent damage during shipment. Remove the panel now — save the hardware — and place the chassis back in the box. You will first wire the front panel.

Most of the front panel controls have already been mounted to eliminate the necessity of your identifying them. Your first step will be to rotate them properly and tighten them to the panel.

Note that each control has a projecting metal tab and that there is a corresponding keying-hole in the chassis near the control.

Step 1-A Rotate each control until the projecting metal tab is positioned in the key-hole as shown in Fig. 1-1. Tighten the hex nut on the control with your combination pliers or an open-end wrench.

Next, you will mount the five slide switches in StrataPack 1 on the front panel. These switches are identified in Fig. 8 as S3, S4, S5, S6 and S7.

Examine these switches. Electrically, they may be mounted any way — there is no “top” or “bottom”. However, there may be a circular indentation on the sliding portion when the rectangular knob is “thrown” in one direction. If so, mount the switches with the indentation toward the bottom of the panel as shown.

Step 1-B Mount the five slide switches as shown in Fig. 8 and Fig. 1-2 using the appropriate hardware. While tightening the switches in place, hold them in the approximate center of the panel hole.

Step 1-C Mount the phone jack, J5, as shown in Fig. 1-3 in the large round hole in the center of the panel. Slip the lockwasher over the jack bushing before mounting it. Before tightening the hex nut, be sure the lugs are positioned as shown in Fig. 8.

Step 1-D Locate the pilot lamp socket and the pilot lamp. Insert the lamp in the socket by pushing down against the spring and turning to the right so that the pins engage the slots.

Step 1-E Mount the pilot lamp socket, SO-1, in the rectangular hole in the center of the panel as shown in Fig. 1-4.

This completes Stage 1. Remember if you have any parts left over from StrataPack 1, you goofed! Go back and check. There is the remote possibility that we generously supplied you with, say, an extra screw or perhaps even two lamp bulbs instead of one. If so, don't try to use them up! But, instead, please put the extra part aside so it can't cause you further trouble.

In the next stage you will begin to “wire up” your KX-100. You'll find that most Stages will take about one-half hour, so you can plan ahead!

Figure 2-1

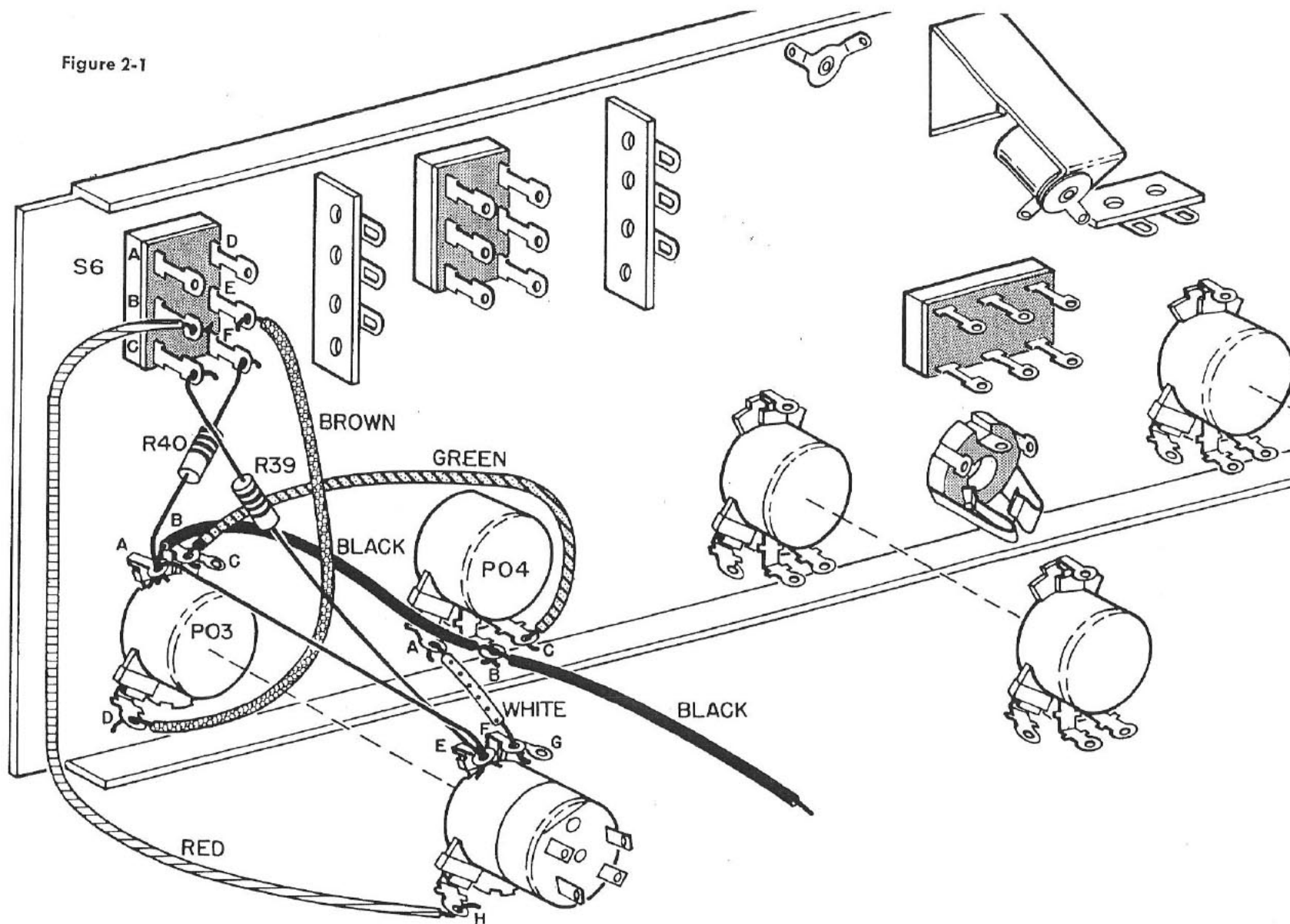

STAGE 2

YOU WILL NEED TO SOLDER in this Stage, so if your soldering iron is not heated, plug it in now and read through the Stage while you are waiting.

Important:

When you are to connect but not solder a wire or part lead to a lug you will be instructed to “connect”. If the lead should be soldered after it is connected, you will be instructed to “solder”. In short, “connect” means “connect” and “solder” means “connect *and* solder”.

Whenever you are instructed to “solder” a lug, you will be told how many leads are on that lug. For example, you might be instructed to “Solder (S-two) one lead of R21 . . .”. The “(S-two)” would indicate that there was another lead previously connected and there should be two leads on the lug at the time you solder. Note that sometimes you will insert a wire completely through a lug (and then over to another). In this case the wire will be treated as “one” even though both ends are coming out of the lug.

In this stage you will begin to wire the dual Volume control PO3, the Loudness switch S6 and the Balance control PO4. Use the parts in StrataPack 2 and, if necessary, refer to Fig. 8. If you have not yet done so, open the hardware box and remove the solder spool, the roll of bare wire, and the roll of insulating spaghetti.

Locate figure 11, the front panel photograph, on separate sheet No. 2. This photo is intended to be a reference — don't try to wire from it!

Refer to Fig. 2-1 for the following steps:

- Step 2-A** Solder (S-one) one end of the brown wire to lug D on the front section of control PO3. Connect the other end of the wire to lug E of switch S6. Dress the wire against the front panel.
- Step 2-B** Solder (S-one) one end of the red wire to lug H on the rear section of PO3. Connect the other end of the wire to lug B on switch S6. Dress the wire against the panel.

- Step 2-C** Cut a $\frac{3}{4}$ " length of bare wire and connect it between lug A on the front section of control PO3 and Lug E on the rear section.
- Step 2-D** Connect the 4" black wire (the longer of the two) between lug A on the front section of control PO3 and center lug B of control PO4.
- Step 2-E** Solder (S-two) one end of the remaining black wire to center lug B of control PO4. The free end will be connected later.
- Step 2-F** Connect the green wire between lug B of the front section of PO3 and lug C of PO4. Dress it as shown in Fig. 2-1 and solder (S-one) lug B of PO3.
- Step 2-G** Cut both leads of one of the 22K ohm resistors, R40, (red, red, orange) to $\frac{5}{8}$ -inch.
- Step 2-H** Solder (S-three) one lead of R40 to lug A on the front section of PO3. Connect the other lead to lug F of switch S6.
- Step 2-J** Cut both leads of the remaining 22K ohm resistor, R39, to $\frac{1}{2}$ -inch. Solder (S-two) one lead to lug E on the rear section of PO3. Connect the other lead to lug C of S6.
- Step 2-K** Connect the white wire between lug F on the rear section of PO3 and lug A of PO4. Solder (S-one) lug F of PO3.

This completes Stage 2. Notice that you now have a wire “hanging loose” from the panel; you will connect more in the next few Stages until you have quite an octopus! Eventually, all of these wires will be connected into the main chassis circuits.

Figure 3-1

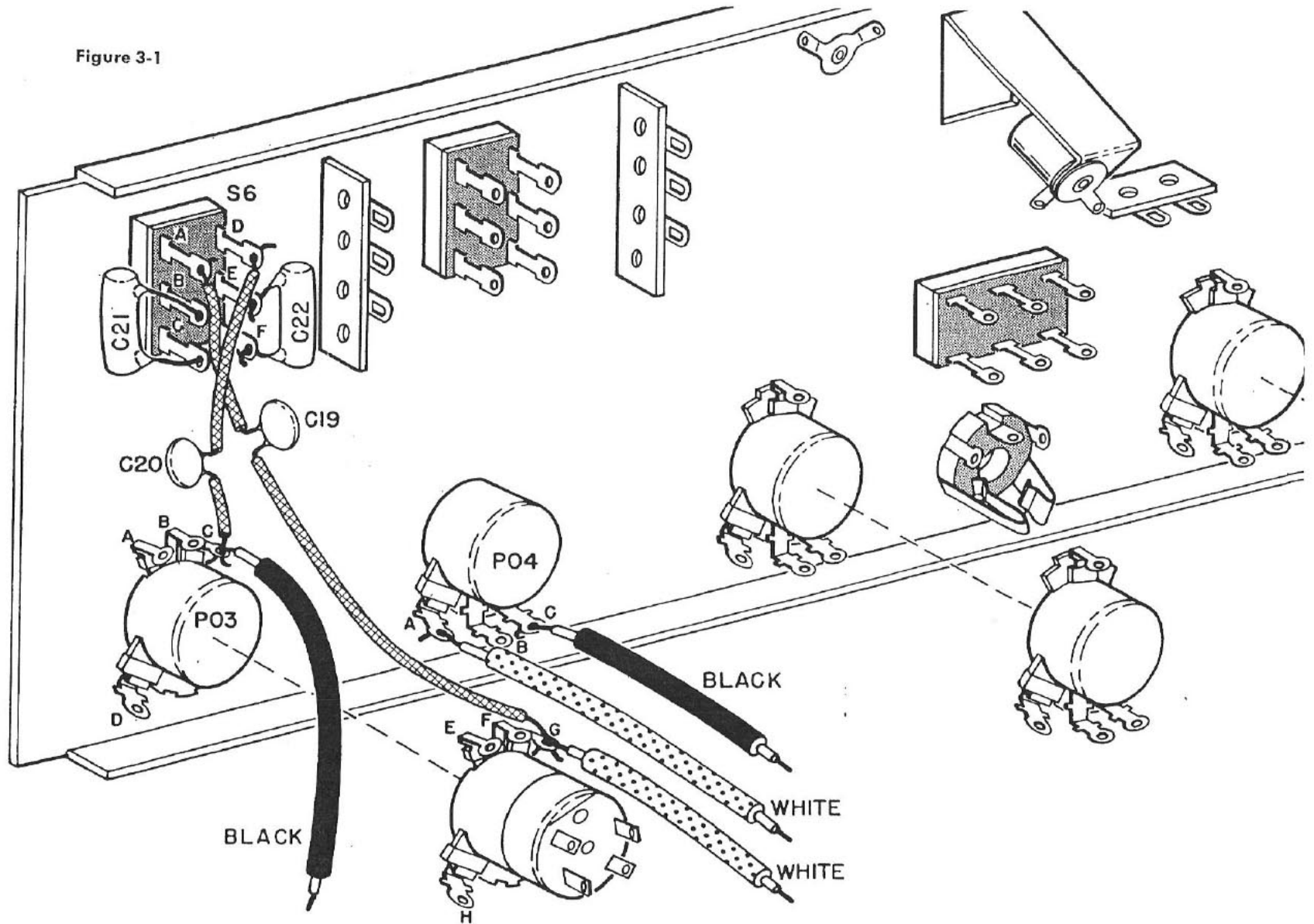

STAGE 3

YOU WILL CONTINUE WIRING the Volume control and Loudness switch in this stage. Refer to Fig. 3-1.

Open StrataPack 3 and remove the four shielded cables. Remove $\frac{1}{4}$ -inch of insulation from both ends of each cable — see page 6. Note that the shielded cables in this stage are colored black and white. However, in future stages the shielded cables will have either a black or a white background color with a different colored tracer (stripe). These cables will be identified by both “colors”, the background color being indicated first. For example, a cable with a black background and a red tracer will simply be called “black-red.”

Set the cables aside and proceed as follows:

Step 3-A Cut all (four) leads of both .022 mfd mylar capacitors to $\frac{1}{2}$ -inch.

Note that one side of the mylar capacitors may be marked “outside foil” or with a line. If so, these marks can be ignored.

Step 3-B Connect one of these, as C21, between lugs B and C of switch S6. Solder lug B (S-two) and lug C (S-two) of S6.

Step 3-C Connect the other .022 mfd capacitor, C22, between lugs E and F of switch S6. Solder lug E (S-two) and lug F (S-two) of switch S6.

Step 3-D Cut both leads of one of the 68 mmf disc capacitors to $1\frac{1}{8}$ -inch. Cut two $\frac{7}{8}$ -inch lengths from the roll of tubular spaghetti.

Step 3-E Cover both leads of the capacitor with the spaghetti and connect it as C20 between lug D of switch S6 and lug C on the front section of control PO3. Solder (S-one) lug D of switch S6.

Step 3-F Locate the 8-inch (longer) black shielded cable and cut off the ground wire at one end. Solder (S-two) the center wire of this end to lug C on PO3.

Step 3-G Cut both leads of the other 68 mmf disc capacitor, C19, to 1-inch. Cut two $\frac{3}{4}$ -inch lengths of spaghetti.

Step 3-H Cover both leads of C19 with spaghetti and connect it between lug A of switch S6 and lug G of control PO3. Solder (S-one) lug A of S6.

Step 3-J Locate the longer white shielded cable and cut the ground wire from one end. Solder (S-two) the center wire of this end to lug G of control PO3.

Step 3-K Locate the remaining white shielded cable and cut the ground wire off one end. Solder (S-two) the center wire at this end to lug A of control PO4.

Step 3-L Locate the remaining (shorter) black shielded cable and cut the ground wire off one end. Solder (S-two) the center wire at this end to lug C of control PO4.

Step 3-M Check to be sure the leads of the capacitors C19, C20, C21, and C22 as well as resistors R39 and R40 are not accidentally shorting to each other at switch S6.

This completes Stage 3. This was a short one but the next, Stage 4, will be longer and will contain some critical wiring. So if you've been working steadily so far this is a good time to take a break before beginning Stage 4. A sleepy kit builder tends to make mistakes.

Figure 4-2

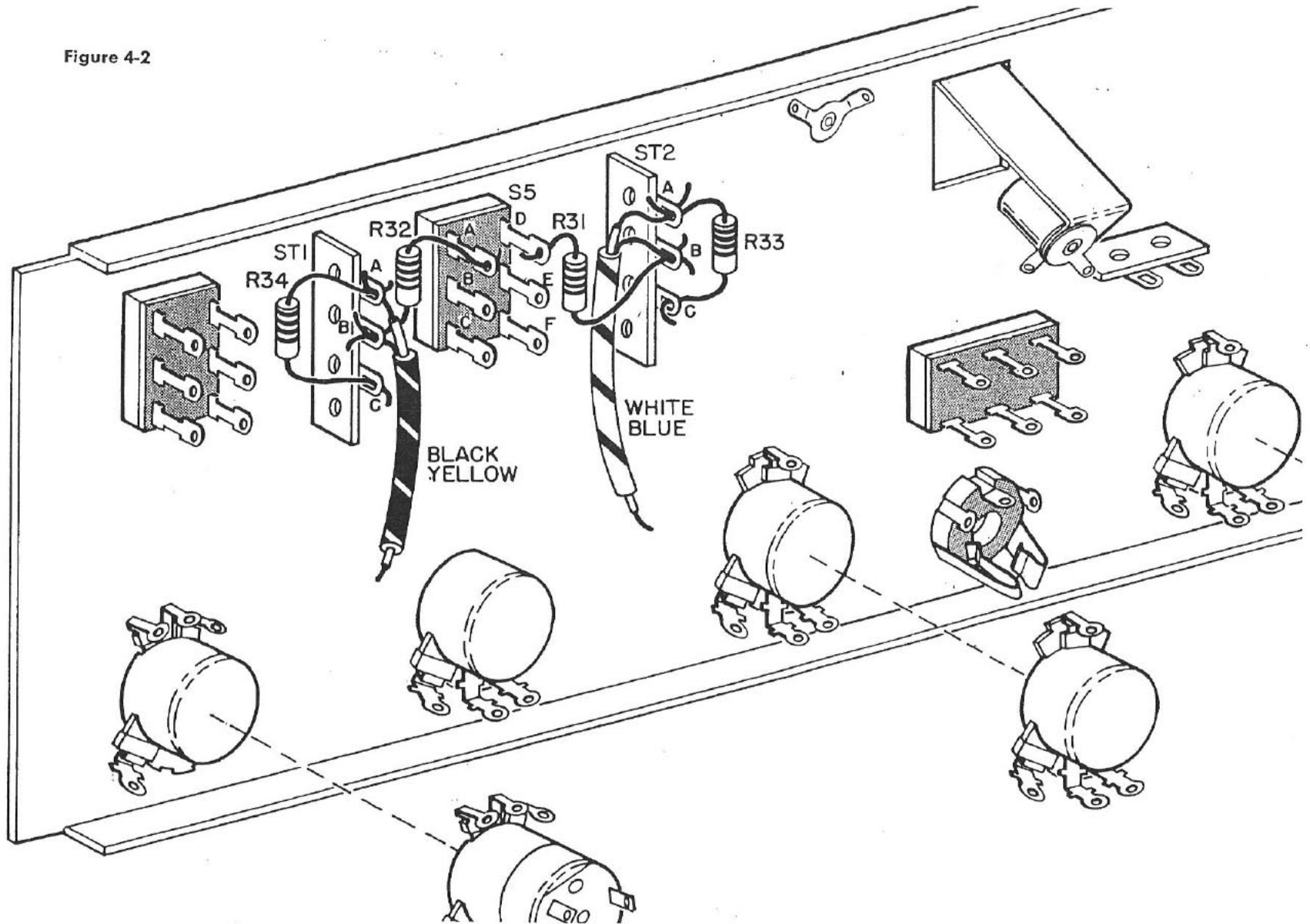

STAGE 4

IN THIS STAGE you will run some long wires, from one end of the panel to the other, to wire the tape monitoring facilities. This wiring is shown in Fig. 4-1 on separate sheet No. 3.

Remove the five shielded cables from StrataPack 4 and remove ¼-inch of insulation at both ends.

- Step 4-A** Cut the ground wire off one end of the black-red cable. Solder (S-one) the center wire at this end to lug 2 on the front deck (section) of the two deck switch S1.
- Step 4-B** Position this cable as shown in Fig. 4-1. At the other end, connect the center wire to lug C of strip ST1; connect the ground wire to lug B of strip ST1.
- Step 4-C** Locate the white-red shielded cable and cut off the ground wire at one end. Solder (S-one) the center wire at this end to lug 8 on the front deck of switch S1.
- Step 4-D** Position the cable as shown. At the other end, connect the center wire to lug C of strip ST2; connect the ground wire to lug B of strip ST2.
- Step 4-E** Solder (S-one) one end of the black wire to lug B of phone jack J5. Connect the other end of the wire to lug B of strip ST3.
- Step 4-F** Locate the black-white shielded cable and cut off the ground wire at one end. Solder (S-one) the center wire at this end to lug B of switch S5.
- Step 4-G** Position the cable as shown. At the other end, connect the center wire to lug A of strip ST3. Solder (S-two) the ground wire to lug B of strip ST3.
- Step 4-H** Cut one lead of each 180 mmf disc capacitor to ½-inch. First install one as C16: Insert the longer lead through lug A of strip ST1, over to and through lug A of switch S5. Position

C16 as shown and connect the shorter lead to lug C. At lug A of S5, bend over the lead and cut it shorter, if necessary.

- Step 4-J** Now install C15: First cut a ¼-inch length of insulating spaghetti. Insert the longer lead through lug A of strip ST2, over to and through lug D of switch S5. Position C15 as shown and slip the spaghetti over the shorter lead. Connect this lead to lug C of strip ST2. At lug D of S5, bend over the lead and cut it shorter, if necessary.

Refer to Fig. 4-2 for the remaining steps.

- Step 4-K** Locate the four 220K ohm resistors (red, red, yellow) and cut both leads of each to ½-inch. Connect one of the resistors, as R34, between lugs A and C of strip ST1. Solder (S-three) lug C of strip ST1.
- Step 4-L** Locate the black-yellow shielded cable. Solder (S-three) the center wire at one end to lug A of strip ST1. Connect the ground wire to lug B of ST1.
- Step 4-M** Connect one of the 220K ohm resistors as R32 between lug B of strip ST1 and lug A of switch S5. Solder (S-three) lug B of ST1 and solder (S-two) lug A of S5.
- Step 4-N** Connect one of the 220K ohm resistors as R33 between lugs A and C of strip ST2. Solder (S-three) lug C.
- Step 4-P** Locate the white-blue shielded cable. Solder (S-three) the center wire to lug A of strip ST2. Connect the ground wire to lug B of ST2.
- Step 4-Q** Connect the remaining 220K ohm resistor as R31 between lug B of ST2 and lug D of S5. Solder (S-three) lug B of ST2 and solder (S-two) lug D of S5.

Figure 5-1

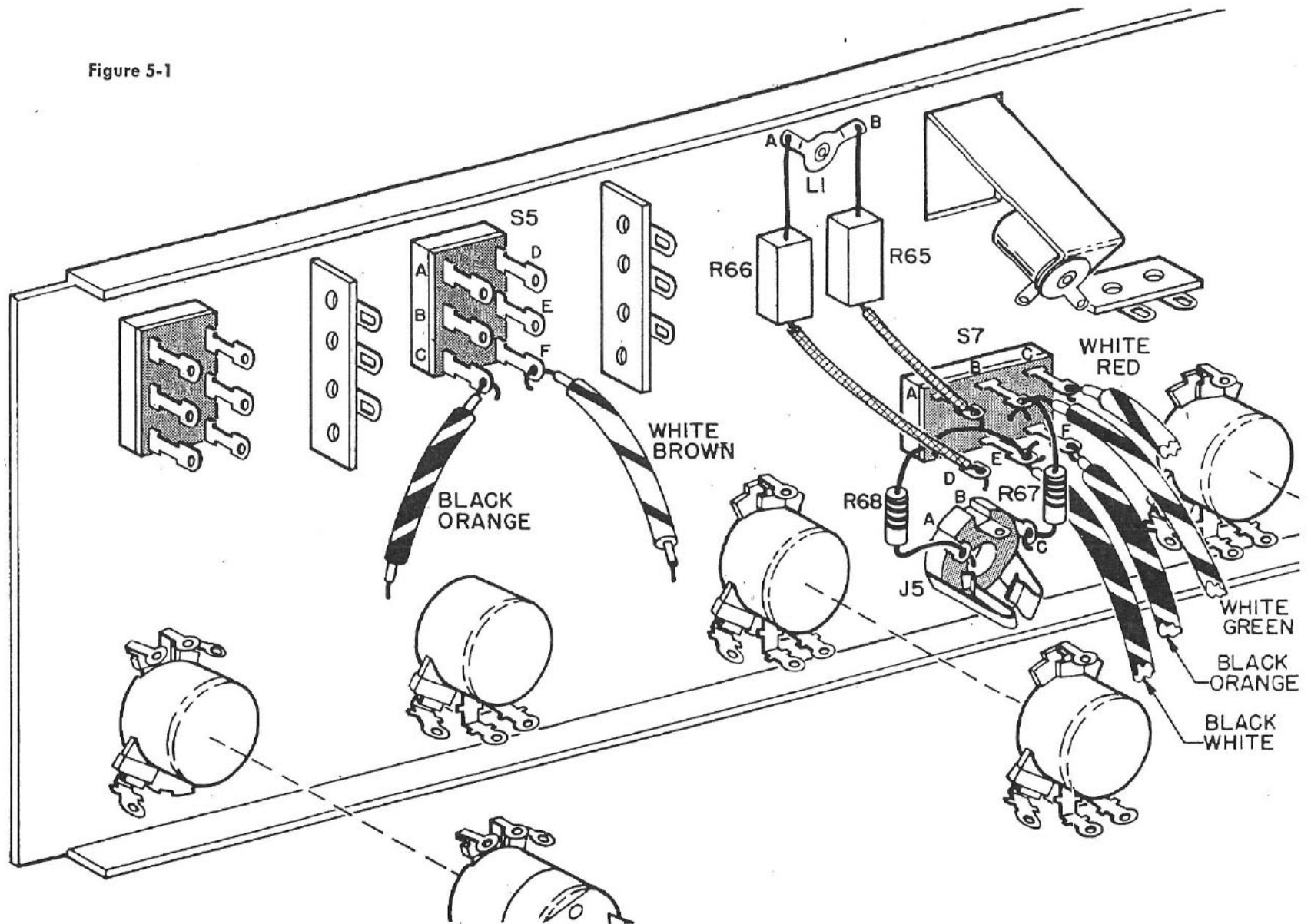

STAGE 5

IN THIS STAGE you will wire the phone jack and speaker switch. Remove the shielded cables from StrataPack 5 and strip ¼-inch of insulation from the center wire at both ends of each.

- Step 5-A** Cut one lead of one 25 ohm, 5 watt resistor, R65 to ¾-inch; cut the other to 1-inch. Position R65 as shown and solder (S-one) the shorter lead to lug B of L1.
- Step 5-B** Cut a ¾-inch length of spaghetti. Slip the spaghetti over the free lead of R65 and solder (S-one) this lead to lug A of switch S7.
- Step 5-C** Cut one lead of the remaining 25 ohm resistor to ¾-inch; cut the other lead to 1½-inch. Position the resistor, R66, as shown and solder (S-one) the shorter lead to A of lug L1.
- Step 5-D** Cut a 1¼-inch length of spaghetti. Slip it over the free lead of R66 and solder (S-one) this lead to lug D of switch S7.
- Step 5-E** Cut off the ground wire at one end of the longer black-orange shielded cable. Solder (S-one) the center wire, at this end, to lug F of switch S7.
- Step 5-F** Cut off the ground wire at one end of the black-white shielded cable. Connect the center wire, at this end, to lug E of switch S7.
- Step 5-G** Cut off the ground wire at one end of the white-red shielded cable. Solder (S-one) the center wire, at this end, to lug C of switch S7.
- Step 5-H** Cut off the ground wire at one end of the white-green shielded cable. Connect the center wire, at this end, to lug B of switch S7.
- Step 5-J** Locate the two 330 ohm, 1-watt resistors (orange, orange, brown). Cut all (four) leads of both to ⅝-inch. Bend the leads at right angles to the resistor body.

- Step 5-K** Connect one of these as R67 between lug B of switch S7 and lug C of jack J5. Solder (S-two) lug B of switch S7 and solder (S-one) lug C of jack J5.
- Step 5-L** Connect the remaining resistor, R68, from lug E of switch S7 and lug A of jack J5. Solder (S-two) lug E of switch S7 and solder (S-one) A of jack J5.
- Step 5-M** Locate the white-brown shielded cable and cut off the ground lead at one end. Solder (S-one) the center wire at this end to lug F of switch S5.
- Step 5-N** Locate the remaining black-orange shielded cable and cut off the ground wire at one end. Solder (S-one) the center wire at this end to lug C of switch S5.

Unless you are technically inclined it might at times seem that you are just connecting up a “meaningless” bunch of wires and parts. Of course, every wire and part in your KX-100 is important to its operation.

For example — let’s take a quick look at the “personal listening facilities” you just wired. Many people like to use phones (as well as regular speakers) for its “different sound” and for its convenience — late at night or when the family is watching a favorite TV show. The section you just wired will permit listening with phones and speakers at the same time or, with phones alone, by turning the speaker switch (S7) off. The two 330 ohm resistors (R67 and R68) are connected in series with the phones to reduce the power applied to them since phones require less power than speakers.

When the Speaker switch S7 is turned OFF the speakers will be disconnected from the output and resistors R65 and R66 are connected in their place to “load” the amplifier — a protective measure.

Every part and wire does have a purpose!

Figure 6-1

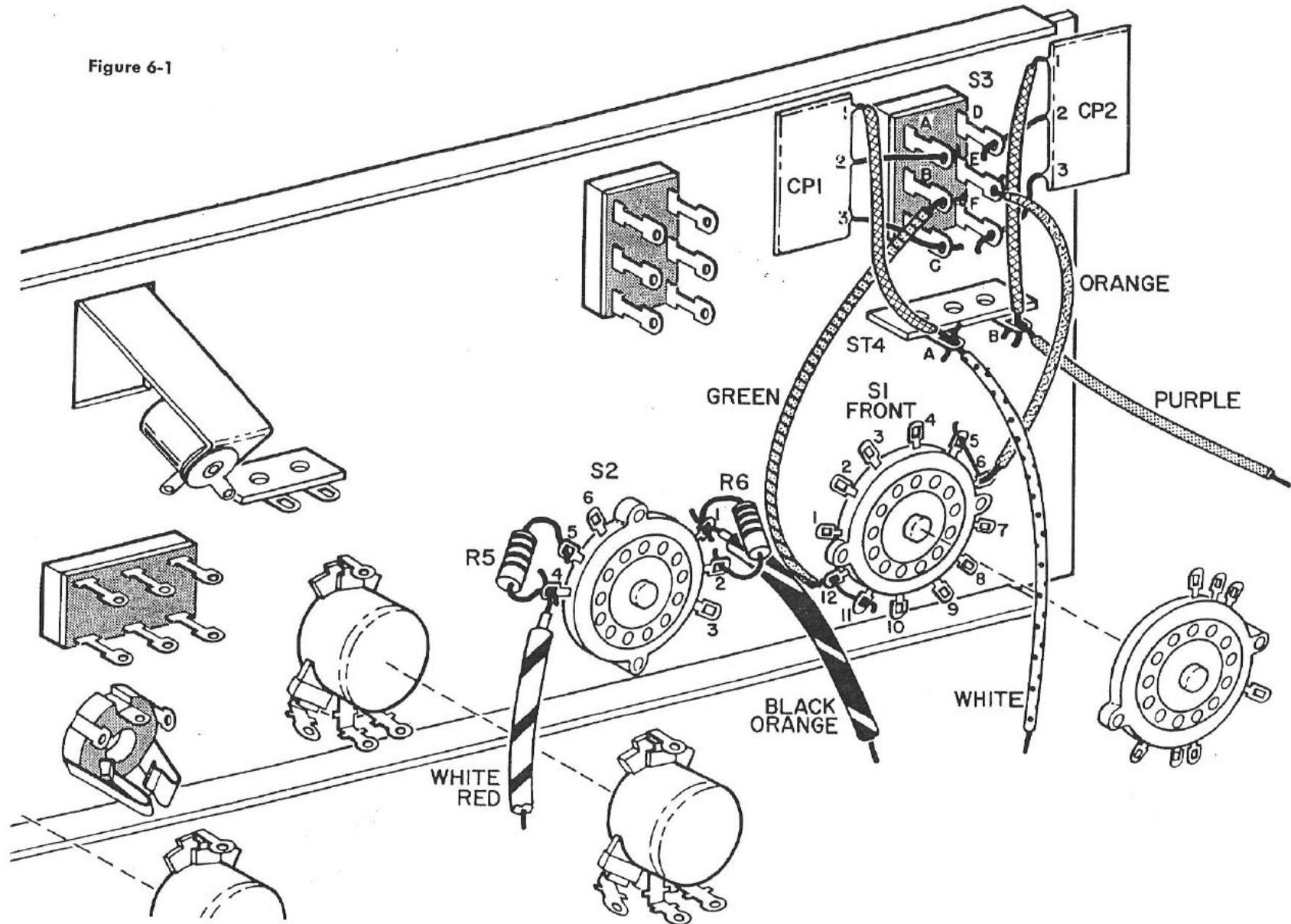

STAGE 6

IN THIS STAGE you will wire the equalization circuits and switch, and the Mode Selector switch. Remove the two shielded cables from StrataPack 6 and strip off ¼-inch of insulation from the center wire at each end. Set the cables aside for now and proceed as follows. Refer to Fig. 6-1.

Step 6-A Remove an extra ¼-inch of insulation from one end of the orange wire. As shown, insert this end of the wire through lug 6 on the front deck of switch S1, bend it over and through lug 5. Solder both lugs — this wire is the only one connected to lugs 5 and 6.

Step 6-B Connect the other end of the wire to lug E of switch S3.

Step 6-C Remove an extra ¼-inch of insulation from one end of the green wire. Insert this end through lug 12 on the front deck of switch S1 and over through lug 11. Solder both lugs — this is the only wire connected to these lugs.

Step 6-D Connect the other end of the green wire to lug B of switch S3.

Dress both of these wires, the orange and the green, down against the front panel. Locate the two Equalization printed circuits.

Step 6-E Cut the leads of both as follows:

- No. 1 — 1⅞-inch
- No. 2 — ½-inch
- No. 3 — ½-inch

Step 6-F Position one of the printed circuits, as CP2, on the right hand side of switch S3. The printing on the circuit plate should be facing you. Solder (S-one) lead No. 3 to lug F of switch S3.

Step 6-G Solder (S-one) lead No. 2 of CP2 to lug D (the top lug) of switch S3.

Step 6-H Cut a 1½-inch length of spaghetti and slip it over lead No. 1 of CP2. Connect lead No. 1 to lug B of ST4.

Step 6-J Position printed circuit CP1 as shown in Fig. 6-1 with the printing on the circuit plate facing away from you. (So you can't read it this way — but it isn't very interesting anyway.) Solder (S-one) lead No. 3 to lug C of S3.

Step 6-K Solder (S-one) lead No. 2 of CP1 to lug A of switch S3.

Step 6-L Cut a 1½-inch length of spaghetti and slip it over lead No. 1 of CP1. Connect lead No. 1 to lug A of ST4.

Step 6-M Solder (S-two) one end of the purple wire to lug B of strip ST4.

Step 6-N Solder (S-two) one end of the white wire to lug A of strip ST4.

Step 6-P Locate the two 100K ohm resistors (brown, black, yellow) and cut all (four) leads (of both) to ½-inch. Connect one of these as R5 between lugs 4 and 5 of switch S2 (the single-deck switch). Solder (S-one) lug 5.

Step 6-Q Cut off the ground wire at one end of the white-red shielded cable. Solder (S-two) the center wire at this end to lug 4 of switch S2.

Step 6-R Connect the remaining resistor as R6 between lugs 1 and 2 of switch S2. Solder (S-one) lug 2.

Step 6-S Cut off the ground wire at one end of the black-orange shielded cable. Solder (S-two) the center wire at this end to lug 1 of switch S2.

Figure 7-1

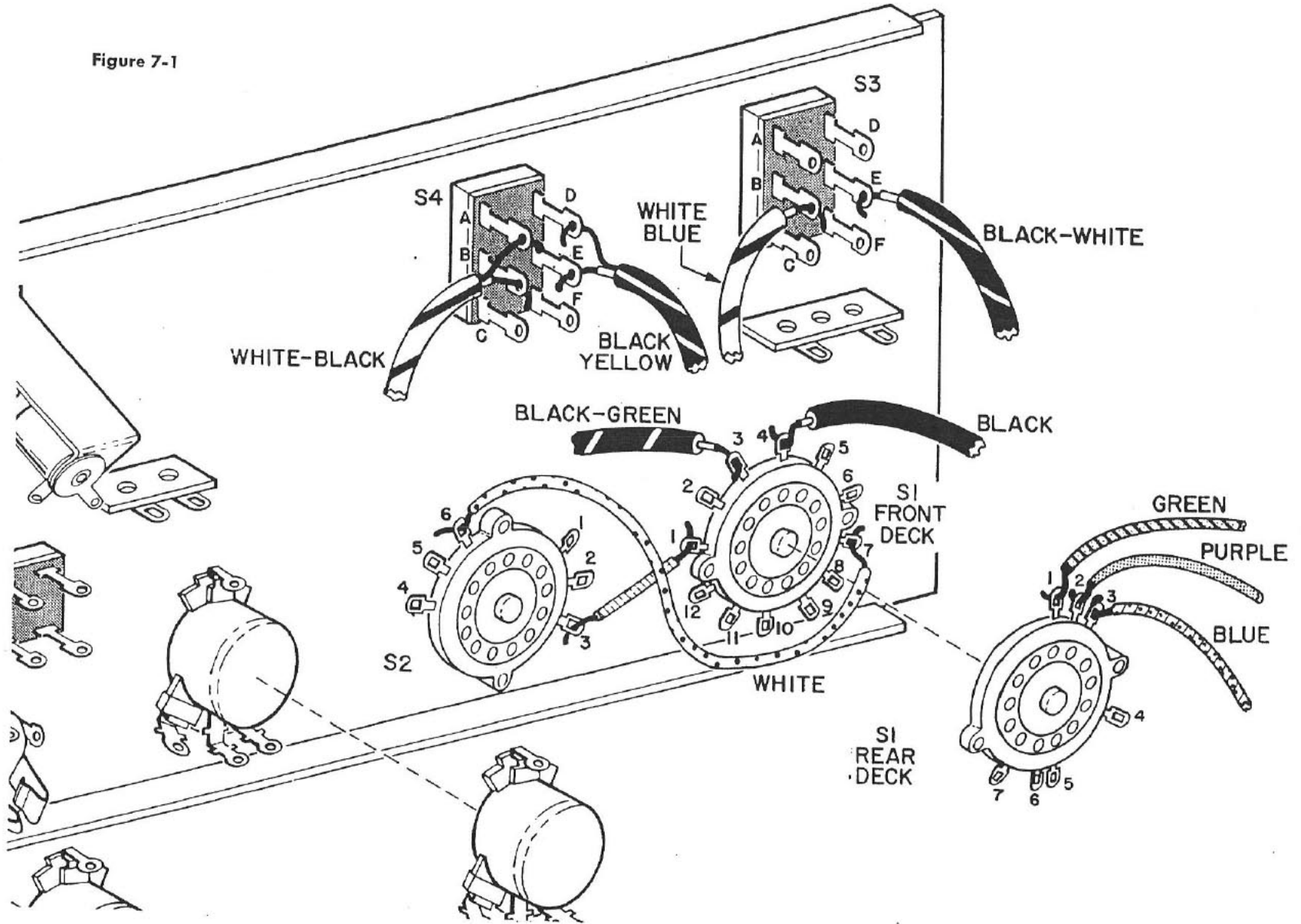

STAGE 7

YOU WILL COMPLETE the front panel wiring in this stage except for the tone controls and a few other wires that will be connected after the panel is attached to the chassis.

As before, remove the six shielded cables from the StrataPack (7) and strip $\frac{1}{4}$ -inch insulation from the center wire at each end.

- Step 7-A** Solder (S-one) one end of the white wire to lug 7 on the front deck of switch S1.
- Step 7-B** Position the white wire exactly as shown, dressed down against the panel. Solder (S-one) the free end to lug 6 of switch S2.
- Step 7-C** Cut a $1\frac{1}{2}$ -inch length of bare wire and a 1-inch length of spaghetti.
- Step 7-D** Solder (S-one) one end of the bare wire to lug 1 on the front deck of switch S1.
- Step 7-E** Slip the spaghetti over the wire and solder (S-one) the wire to lug 3 of switch S2.
- Step 7-F** Cut off the ground wire at one end of the black-green shielded cable. Solder (S-one) the center wire at this end to lug 3 on the front deck of switch S1.
- Step 7-G** Cut off the ground wire at one end of the black shielded cable. Solder (S-one) the center wire at this end to lug 4 on the front deck of S1.
- Step 7-H** Cut off the ground wire at one end of the black-white shielded cable. Solder (S-two) the center wire at this end to lug E of switch S3.
- Step 7-J** Cut off the ground wire at one end of the white-blue shielded cable. Solder (S-two) the center wire of this end to lug B of switch S3.
- Step 7-K** Locate the white-black shielded cable. Solder (S-one) the center wire to lug B of switch S4. Solder (S-one) the ground wire to lug A of S4.
- Step 7-L** Locate the black-yellow shielded cable. Solder (S-one) the center wire to lug E of switch S4. Solder (S-one) the ground wire to lug D of S4.
- Step 7-M** Solder (S-one) one end of the blue (glass) wire to lug 3 on the rear deck of switch S1.
- Step 7-N** Solder (S-one) one end of the purple wire to lug 2 on the rear deck of switch S1.
- Step 7-P** Solder (S-one) one end of the green (glass) wire to lug 1 on the rear deck of switch S1.

This completes your work on the front panel for now. Later you will mount it on the chassis and finish it. Carefully go through the next two steps before laying it aside.

- Step 7-Q** Inspect lugs 1, 2 and 3 on the rear deck of switch S1. Make sure these "close together" lugs are not shorted to each other by excess solder.

- Step 7-R** There are a number of wires and leads on switch S3. Check there also for unwanted shorts. (As a matter of fact, check *everywhere!*)

Figure 8-1

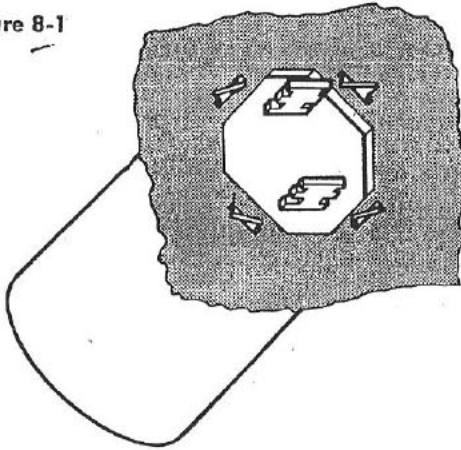

CATHODE
SIDE

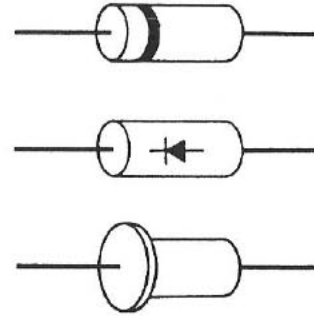

Figure 8-3

ANODE
SIDE

Figure 8-2

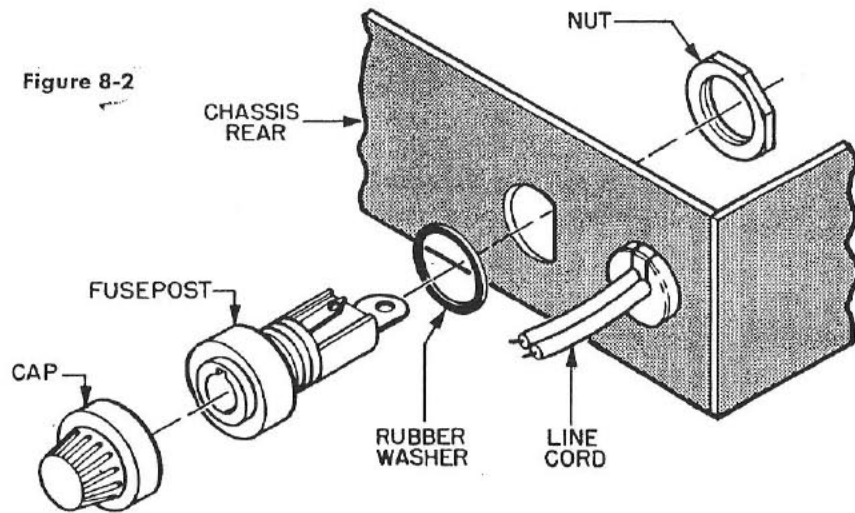
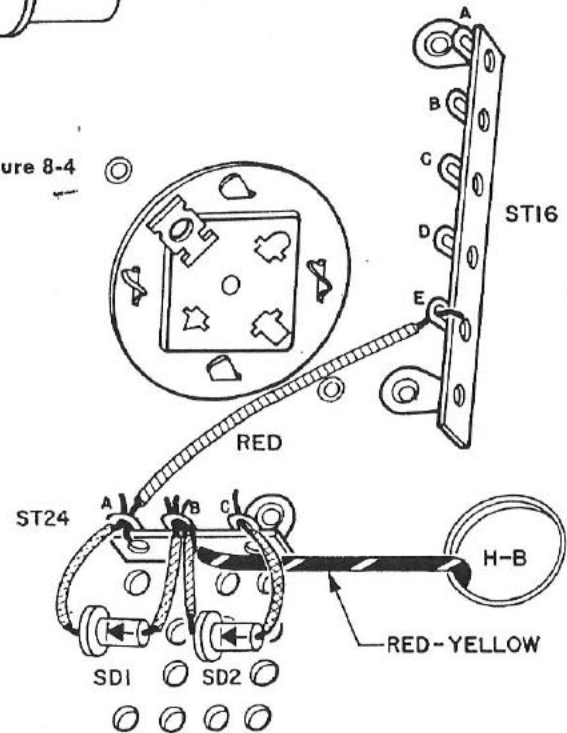

Figure 8-4



STAGE 8

REMOVE THE CHASSIS from the carton and place it on your work table. To protect the front panel you can set it back in the carton in place of the chassis.

In addition to the parts in StrataPack 8 you will also need the three electrolytic capacitor cans C1, C2 and C3. Let's mount them first and get them out of the way.

All three capacitors are mounted as shown in Fig. 8-1. Note that the four tabs on the capacitor can are inserted in the appropriate holes on the chassis. While the can is held firmly against the chassis the tabs are twisted about 90 degrees to lock the can in place.

These capacitor cans contain from one to three electrolytic capacitors. Normally, the can itself forms the negative side common to all the capacitors while the inner lugs serve to connect to the positive side of the capacitors. The individual capacitors can be identified by square, triangle, or half-round cut-outs next to the positive lugs. It is, therefore, important that the cans be oriented properly before insertion.

Refer to Fig. 8-1 and to Fig. 9 on the separate sheet.

- Step 8-A** Locate the single capacitor C1. It is the only can covered with insulation. Mount it on the insulating wafer with its single inner lug oriented as shown.
- Step 8-B** Locate the dual capacitor C2. Mount it as shown with the 40 mfd. (triangle) toward chassis hole H-D.
- Step 8-C** Locate the triple capacitor C3. Mount it as shown with the 20 mfd. (triangle) section toward strip ST9.
- Step 8-D** Refer to Figure 8-2 and mount the fusepost in the hole in the back skirt of the chassis marked "3.2 AMP SLO-BLO". Be careful not to tighten the nut excessively or the fusepost may crack.

As shown in Fig. 8-4:

- Step 8-E** Connect the red-yellow power transformer lead (hole H-B) to lug B of strip ST24.
- Step 8-F** Connect the red wire (from StrataPack 8) between lug A of strip ST24 and lug E of strip ST16.

Next you will mount the two silicon diodes used in the voltage-doubler power supply. As pointed out on page 6, these diodes are heat sensitive and must be carefully soldered. Just as important — the diodes are polarized and must be installed "pointing" in the right direction.

Cut all four leads of both silicon diodes to 1¼-inch. Cut four ¾-inch lengths of spaghetti.

Now examine the diodes and identify the cathode end as shown in Fig. 8-3. Notice that the cathode may be identified by a drawing, a line, an extended "hat brim", or a combination of these symbols.

Tin the end of each diode lead, as explained on page 6, holding the pliers as a heat sink between the diode body and the soldering iron. Then slip the spaghetti over each diode lead.

- Step 8-G** Position one of the diodes, SD1, as shown in Fig. 8-4. Solder (S-two) the cathode lead to lug A of strip ST24.
- Step 8-H** Connect the other (anode) lead of SD1 to lug B of ST24.
- Step 8-J** Position diode SD2 as shown. Solder (S-three) the cathode lead to lug B of strip ST24.
- Step 8-K** Solder (S-one) the other anode lead of SD2 to lug C of strip ST24.

STAGE 9

THIS WILL BE A LONG STAGE — about 45 minutes' worth — and it contains some critical wiring. If you don't have time to complete it in one "sitting", take a break and start "fresh" tomorrow.

You will now wire the heater circuits of the V5 and V6, the 12AX7 driver stages and the 7868 power output tubes. It is important that these AC-carrying wires be positioned as shown in Fig. 9-1 on separate sheet No. 3. Be sure, also, that your "vertical" is satisfactory. Dress these wires down on the chassis.

Step 9-A Twist together the green and yellow power transformer leads (from hole H-B). Position these leads, as shown, dressed down against the chassis.

Step 9-B Connect the green transformer lead to lug C of strip ST16. Connect the yellow lead to lug D.

Remove the roll of twisted yellow-green wire from StrataPack 9. You will use this wire for the heater circuits. Cut it to the indicated length and, of course, strip off ¼-inch of insulation from the ends before connecting.

Step 9-C Cut a 5½-inch length. At one end connect the green wire to lug C of strip ST16; connect the yellow wire to lug D of strip ST16.

Step 9-D Position the pair exactly as shown, dressed down on the chassis. Connect the green wire to lug 4 of socket V10. Connect the yellow wire to lug 5 of socket V10.

Step 9-E Cut a 4½-inch length. At one end, connect the green wire to lug 4 of socket V9; connect the yellow wire to lug 5 of socket V9.

Step 9-F Position the pair as shown dressed down to the chassis. Connect the green wire to lug 4 of socket V8; connect the yellow wire to lug 5 of socket V8.

Before completing the heater wiring, you will wire the cathode circuits of the 7868 output tubes.

Step 9-G Connect one end of the 5½-inch (shorter) brown wire to lug B of strip ST16. Position the wire as shown and connect the other end to lug 3 of socket V10.

Step 9-H Connect one of the 2½-inch (shorter) white wires between lug 3 of socket V10 and lug 3 of socket V9. Solder (S-two) lug 3 of V10.

Step 9-J Connect the longer white wire from lug 3 of socket V9 to lug 3 of socket V8. Solder (S-two) lug 3 of socket V9.

Step 9-K Connect the remaining white wire from lug 3 of socket V8 to lug 3 of socket V7. Solder (S-two) lug 3 of socket V8.

Step 9-L Connect one end of the remaining brown wire to lug 3 of socket V7. Position the wire as shown and connect the other end to lug A of strip ST20.

Step 9-M Cut a 1½-inch length of bare wire and a ¾-inch length of spaghetti. On socket V7, insert one end of the bare wire through lug 4 and over to lug 3. Slip the spaghetti over the wire and connect the other end to lug 5 of socket V8.

Solder (S-three) lug 3 of socket V7

Solder (S-one) lug 4 of socket V7

Solder (S-two) lug 5 of socket V8.

Step 9-N Cut a 1¾-inch length of bare wire and a 1¼-inch length of spaghetti. Slip the spaghetti over the wire and connect it between lug 5 of socket V7 and lug 4 of socket V8.

Solder (S-one) lug 5 of socket V7

Solder (S-two) lug 4 of socket V8

Step 9-P



Cut a 4½-inch length of the twisted pair. Strip ½-inch of insulation from both ends of the green wire; strip ¼-inch insulation from the yellow wires, as usual.

Step 9-Q



At one end, solder (S-one) the yellow wire to lug 9 of socket V6. Connect the green wire to both lugs 4 and 5 of V6 and solder it. (This is the only connection to these lugs.)

Step 9-R



At the other end, connect the yellow wire to lug 9 of V5. Connect the green wire to both lugs 4 and 5 of V5. Dress these wires down against the chassis.

Step 9-S



Cut a 5½-inch length of the twisted pair. Solder (S-two) the yellow wire to lug 9 of socket V5.

Step 9-T



Solder the green wire to lug 4 of socket V5. Also, solder lug 5 of V5.

Step 9-U



At the other end of the twisted pair, connect the green wire to lug C of strip ST16; connect the yellow wire to lug D of strip ST16.

Step 9-V



Connect one end of the blue wire to lug B of strip ST16. Dress the wire as shown and solder (S-one) the other end to lug 5 of socket V4.

Step 9-W



Solder (S-one) one end of one of the 4-inch (longer) yellow wires to lug 4 of socket V4. Position the wire as shown and solder (S-one) the other end to lug 5 of socket V3.

Step 9-X



Solder (S-one) one end of the remaining 4-inch yellow wire to lug 4 of socket V3. Position the wire as shown and solder (S-one) the other end to lug 5 of socket V2.

Step 9-Y



Solder (S-one) one end of the remaining shorter yellow wire to lug 4 of socket V2. Solder (S-one) the other end to lug 5 of socket V1.

Step 9-Z



Solder (S-one) one end of the black wire to lug 4 of socket V1. Connect the other end to lug L4.

This completes the wiring of Stage 9. It had to — we ran out of letters! It cannot be over-emphasized that the “dressing” in this stage is particularly important. Therefore, before going on to the next stage make certain that all of the wires you installed in this stage are positioned exactly as shown in Fig. 9-1 and are dressed right down on the chassis.

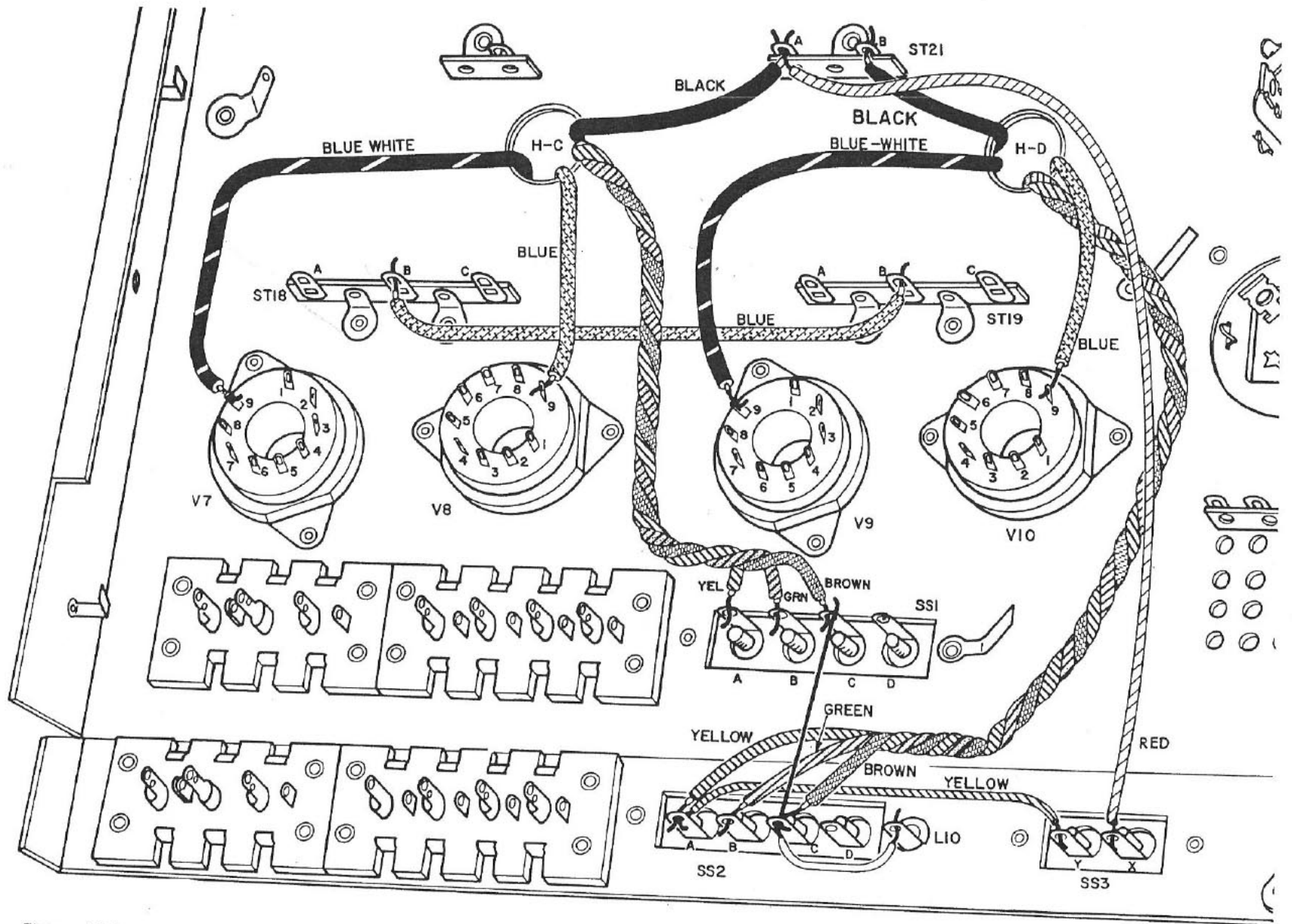

Figure 10-1

STAGE 10

IN THIS STAGE you will work on the 7868 power output stages. For one thing, you will connect most of the output transformer leads to get them out of your way.

Since only a few parts are required for this and the next stage, they have been combined in one StrataPack marked "StrataPack 10-11".

Step 10-A Connect the blue wire (in StrataPack 10-11) from lug B of strip ST18 to lug B of strip ST19.

The leads from channel A transformer T3 project from hole H-C and the leads from channel B transformer T2 project from hole H-D. Note that each transformer has two blue leads, one of which will have either a white or yellow tracer. It will be identified as the "blue-white" lead.

Step 10-B Solder (S-one) the blue-white T3 output transformer lead (hole H-C) to lug 9 of socket V7.

Step 10-C Solder (S-one) the blue T3 output transformer lead (hole H-C) to lug 9 of socket V8.

Step 10-D Solder (S-one) the blue-white T2 output transformer lead (hole H-D) to lug 9 of socket V9.

Step 10-E Solder (S-one) the blue T2 output transformer lead (hole H-D) to lug 9 of socket V10.
Make sure these four transformer leads are carefully dressed down to the chassis.

Twist together the yellow, green and brown leads from transformer T3 (hole H-C) and position them as shown in Fig. 10-1. These leads will be connected to the screw-type terminal strip SS1.

Step 10-F Transformer T3 connections to strip SS1:

Solder (S-one) the yellow lead to lug A.

Solder (S-one) the green lead to lug B.

Connect the brown lead to lug C.

The yellow and green leads should be soldered.

Step 10-G Connect the black T3 transformer lead from hole H-C to lug A of strip ST21.

Twist together the yellow, green and brown leads of output transformer T2 (hole H-D) and position them as shown in Fig. 10-1. These leads will be connected to the screw-type terminal strip SS2.

Step 10-H Transformer T2 (hole H-D) connections to strip SS2:



Connect the yellow lead to lug A

Solder (S-one) the green lead to lug B

Connect the brown lead to lug C.

Step 10-J Connect the yellow wire (from StrataPack 10-11) from lug A of strip SS2 to lug Y of strip SS3. Solder (S-one) lug Y of SS3. Solder (S-two) lug A of SS2.

Step 10-K Connect the T2 black lead (hole H-D) to lug B of strip ST21.

Step 10-L Connect a red wire from lug X of strip SS3 to lug A of Strip ST21. Solder (S-one) lug X of strip SS3.

Step 10-M Cut a 2½-inch length of bare wire and a ¾-inch length of spaghetti.

Step 10-N Insert the bare wire through lug C of strip SS2 over to and connect it to lug C of strip SS1. Slip the spaghetti over the wire projecting from lug C of SS2 and connect the free end to lug L10. Solder (S-two) lug C of strip SS2.

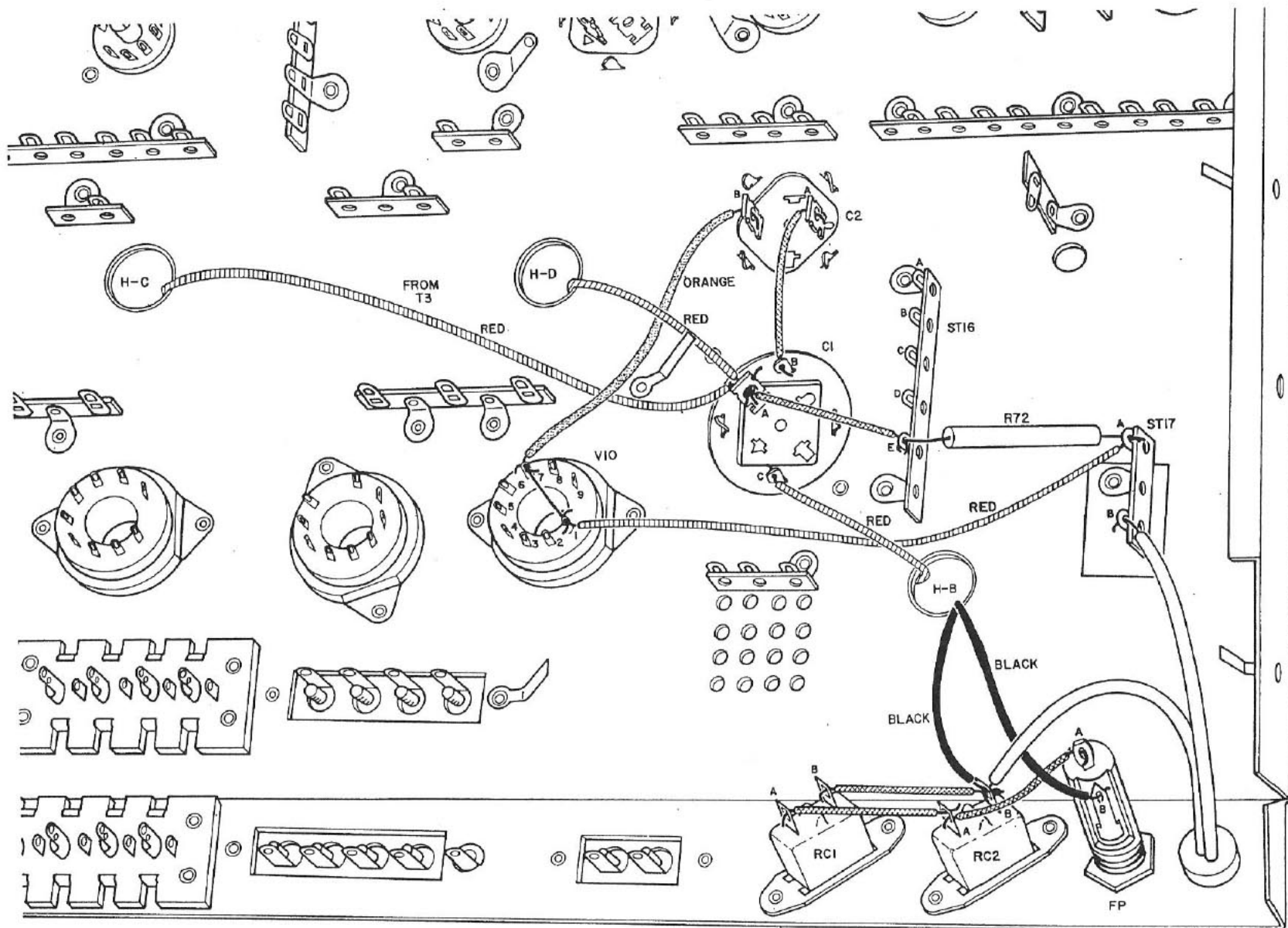

Figure 11-1

STAGE 11

YOU WILL NOW CONNECT the power transformer leads to get them out of the way. Some of the power supply wiring will be done at the same time.

- Step 11-A** Solder (S-one) the red T1 lead from hole (H-B) to outer lug C of electrolytic capacitor C1.
- Step 11-B** Cut three 2-inch lengths of bare wire and three 1¼-inch lengths of spaghetti. Solder (S-one) one end of a bare wire to lug B of receptacle RC1. Slip the spaghetti over the wire and connect the other end to lug B of RC2.
- Step 11-C** Use a bare wire and piece of spaghetti to connect lug A of RC1 to lug A of RC2. Solder (S-one) lug A of RC1.
- Step 11-D** Connect one of the black power transformer leads (from hole H-B) to lug B of RC2; connect one of the power cord leads to lug B of RC2. Solder (S-three) lug B of RC2.
- Step 11-E** Solder (S-two) one end of the remaining bare wire to lug A of RC2. Slip the spaghetti over the wire and connect the other end to center lug A of the fusepost.
- Step 11-F** Connect the remaining power cord lead to lug B of strip ST17.
- Step 11-G** Solder (S-one) the remaining black transformer lead to (side) lug B of fusepost FP. If necessary, bend up the lug slightly.
- Step 11-H** Locate the T3 red lead (hole H-C) and the T2 red lead (hole H-D). Position these leads as shown and connect them to lug A of capacitor C1.
- Step 11-J** Cut a 2-inch length of bare wire and a 1⅜-inch length of spaghetti. Solder (S-three) one end of one bare wire to lug A of C1. Slip the spaghetti over the wire and connect the other end to lug E of strip ST16.
- Step 11-K** Connect the 2.5K ohm resistor R72 between lug E of strip ST16 and lug A of strip ST17. Dress the resistor up off the chassis and cut off any excess lead length. Solder (S-three) lug E of ST16.
- Step 11-L** Solder (S-two) one end of the red wire to lug A of ST17. Position the red wire as shown and connect the other end to lug 1 of socket V10.
- Step 11-M** Connect the orange wire from lug 7 of socket V10 to lug B of capacitor C2.
- Step 11-N** Cut a 1⅞-inch bare wire. Connect it between lugs 1 and 7 of socket V10. Run the wire directly across the socket and cut off the excess wire, if any. Solder (S-two) lug 7.
- Step 11-P** Cut a 1¾-inch length of bare wire and a 1⅞-inch length of spaghetti. Solder (S-one) one end of the bare wire to outer lug B of capacitor C1.
- Step 11-Q** Slip the spaghetti over the wire and solder (S-one) the other end to lug A of capacitor C2.
- Step 11-R** Resistor R72 normally becomes quite hot — check to be sure it is positioned up off the chassis and that no wires are touching it.
- Step 11-S** Check the soldered connections at lugs B and C of capacitor C1 — be sure the solder or wires are not accidentally shorted to the chassis.

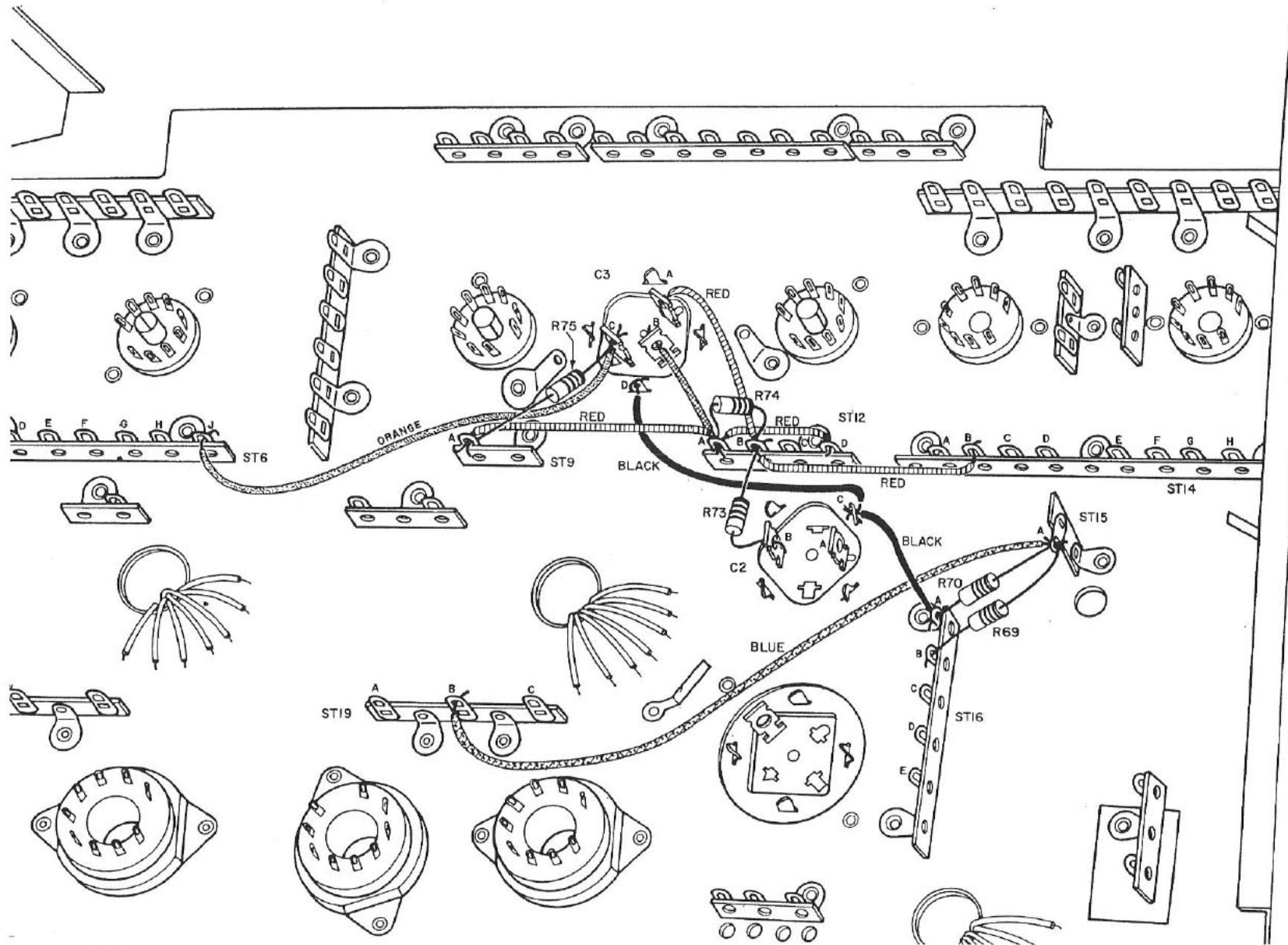

Figure 12-1

STAGE 12

YOU WILL COMPLETE the power supply wiring in this stage. Since these leads carry high dc voltage in the completed amplifier, be sure you position them correctly and that the connections are securely soldered.

Step 12-A Solder (S-one) one end of the black wire to outer lug D of capacitor C3. Connect the other end to outer lug C of capacitor C2.

Step 12-B Cut a 1 $\frac{3}{4}$ -inch length of bare wire and a 1 $\frac{1}{8}$ -inch length of spaghetti. Solder (S-two) one end of the wire to outer lug C of capacitor C2.

Step 12-C Slip the spaghetti over the wire and connect the other end to lug A of strip ST16.

Step 12-D Connect the blue wire between lug A of strip ST15 and lug B of strip ST19. Slip it under the wire you just connected (Step 12-C).

Step 12-E Cut both leads of the 6.8K ohm resistor R70 (blue, grey, red) to $\frac{5}{8}$ -inch. Connect R70 between lug A of strip ST16 and lug A of strip ST15. Solder (S-two) lug A of ST16.

Step 12-F Cut both leads of the 3.3K ohm resistor R69 (orange, orange, red) to $\frac{3}{4}$ -inch. Connect R69 from lug B of strip ST16 to lug A of strip ST15. Solder (S-three) lug A of ST15. Solder (S-three) lug B of ST16.

Step 12-G Cut both leads of the 1K ohm resistor R73 (brown, black, red) to $\frac{5}{8}$ -inch. Connect R73 between lug B of capacitor C2 and lug B of strip ST12. Solder (S-two) lug B of C2.

Step 12-H Connect one of the 3 $\frac{1}{2}$ -inch (longer) red wires between lug B of ST12 and lug B of strip ST14.

Step 12-J Connect one of the 2 $\frac{1}{2}$ -inch (shorter) red wires between lug B of strip ST12 and lug A of capacitor C3. Solder (S-one) lug A of C3.

Step 12-K Connect the remaining longer red wire from lug A of strip ST12 to lug A of strip ST9.

Step 12-L Connect the remaining shorter red wire from lug A of strip ST12 to lug D of strip ST12.

Step 12-M Cut a 1 $\frac{1}{2}$ -inch bare wire and a 1-inch length of spaghetti. Slip the spaghetti over the wire and connect it between lug A of strip ST12 and lug B of capacitor C3.

Step 12-N Cut both leads of the 2.2K ohm resistor R74 (red, red, red) to $\frac{1}{2}$ -inch. Bend the leads as shown and connect R74 between lug A and B of strip ST12. Solder (S-four) lug B of strip ST12. Solder (S-four) lug A of strip ST12.

Step 12-P Connect the orange wire from lug C of capacitor C3 to lug J of strip ST6.

Step 12-Q Cut both leads of the 100K ohm resistor R75 (brown, black, yellow) to $\frac{7}{8}$ -inch. Connect R75 from lug C of C3 to lug A of ST9. Solder (S-two) lug C of capacitor C3.

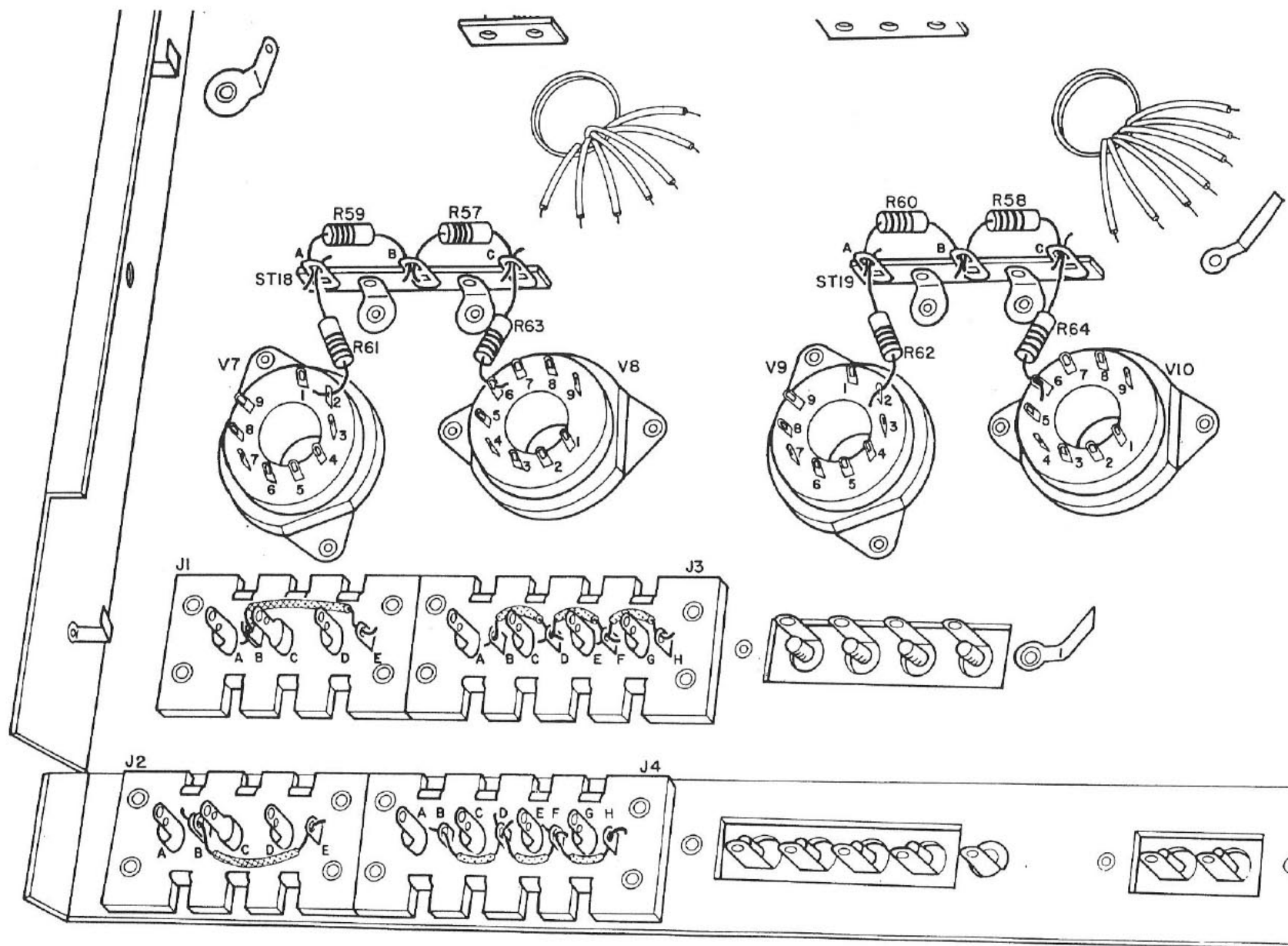

Figure 13-1

STAGE 13

YOUR CHASSIS is almost ready to meet the front panel you previously wired! Before they get together the input jacks J1, J2, J3 and J4 will need to be prepared. You will do this now.

The "ground" connections on the input jacks J1, J2, J3 and J4 must be connected together. You will use bare wire and spaghetti to do this. The first line in each step will indicate the necessary length of wire and spaghetti.

Step 13-A 1½-inch bare wire; 1-inch spaghetti. Connect lug B of jack J1 to lug E of jack J1.

Step 13-B 1½-inch bare wire; 1-inch spaghetti. Connect lug B of jack J2 to lug E of jack J2.

Step 13-C 1-inch bare wire; ¾-inch spaghetti. Connect lug B of jack J3 to lug D of jack J3.

Step 13-D 1-inch bare wire; ¾-inch spaghetti. Connect lug D of jack J3 to lug F of jack J3.

Step 13-E 1-inch bare wire; ¾-inch spaghetti. Connect lug F of jack J3 to lug H of jack J3.

Step 13-F 1-inch bare wire; ¾-inch spaghetti. Connect lug B of jack J4 to lug D of jack J4.

Step 13-G 1-inch bare wire; ¾-inch spaghetti. Connect lug D of jack J4 to lug F of jack J4.

Step 13-H 1-inch bare wire; ¾-inch spaghetti. Connect lug F of jack J4 to lug H of jack J4.

Since none of these wires are soldered make sure the connections are tight. Also, of course, be sure these (shorter) ground lugs are not accidentally shorted to the longer "hot" lugs.

Now wire the grid circuits of the 7868 power output tubes as follows:

Step 13-J Cut all eight leads of the four 1K ohm resistors (brown, black, red) to ½-inch.

Step 13-K Connect one of these, as R61, from lug 2 of socket V7 to lug A of strip ST18. Solder (S-one) lug 2 of socket V7.

Step 13-L Connect another, as R63, from lug 6 of socket V8 to lug C of strip ST18. Solder (S-one) lug 6 of socket V8.

Step 13-M Connect another, as R62, from lug 2 of socket V9 to lug A of strip ST19. Solder (S-one) lug 2 of socket V9.

Step 13-N Connect the last 1K ohm resistor, as R64, from lug 6 of socket V10 to lug C of strip ST19. Solder (S-one) lug 6 of socket V10.

Step 13-P Cut all eight leads of the four 330K ohm resistors (orange, orange, yellow) to ½-inch.

Step 13-Q Connect one as R59 between lugs A and B of strip ST18.

Step 13-R Connect another, as R57, between lugs B and C of strip ST18. Solder (S-three) lug B of strip ST18.

Step 13-S Connect another, as R60, between lugs A and B of strip ST19.

Step 13-T Connect the remaining resistor, as R58, between lugs B and C of strip ST19. Solder (S-four) lug B of strip ST19.

STAGE 14

YOU WILL NOW MOUNT the front panel on the chassis as shown in Fig. 14-1 on separate sheet No. 3. Turn over the chassis, to its normal operating position, with the open front facing you. Remove the front panel from the carton. Open StrataPack 14 and remove the four ¼-inch self-tapping screws.

Place the front panel up against the chassis with the pilot light on top, tuck all the wires connected to the front panel underneath the chassis. Now fasten the panel to the chassis with four screws — “start” all four before tightening them.

Remove the length of large spaghetti from StrataPack 14. Cut six ¾-inch lengths of the spaghetti.

Step 14-A Note that there are three metal lugs on each edge of the chassis identified as L7, L8, L9, L11, L12 and L13. Bend these out nearly straight with your pliers.

Step 14-B On the left side, slip a piece of spaghetti over metal lug L7 near socket V1 and metal lug L8 near chassis lug L4. Lug L9 near jack J1 is not insulated.

Step 14-C Refer to Fig. 9 and locate lug L5 near strip ST19. Straighten it out and cover it with spaghetti.

Step 14-D Bend lug L5 down over the leads near it to hold them in place. This includes the red, blue, green, yellow and brown leads of T2 from hole H-D and the red lead of T3 from hole H-C.

Step 14-E Locate lug L6 near screw-strip SS1. Straighten it out and cover it with spaghetti.

Step 14-F Bend lug L6 down over the green, yellow and brown leads of T2 to hold them in place.

Step 14-G On the right side, slip the spaghetti over lug L11 near strip ST13 and lug L13 near the power cord. Lug L12 near strip ST14 is not insulated.

Step 14-H Connect one end of the black glass wire in StrataPack 14 to lug F of strip ST5 (near V2). As shown, bend the wire over to the rear deck of switch S1.

Remove two of the 8½-inch lengths of spiral shield from the Hardware Box.

Locate the green and blue glass covered wires connected to the rear deck of switch S1. Straighten out these wires as well as the black wire you just connected. Push them through one of the spiral metal shields. Position the shield along the edge of the chassis resting on the metal lugs as shown in Fig. 14-2.

You will now connect the three leads from the “cable” you have made to the input jacks on J2. If you find the leads are a little too long, don’t hesitate to cut them shorter.

Step 14-J Solder (S-two) the black wire to lug E of input jack J2.

Step 14-K Connect the green wire to lug C of jack J2.

Step 14-L Solder (S-one) the blue wire to lug A of jack J2.

Insert the yellow, orange, and white glass insulated wires (in StrataPack 14) through the other 8½-inch spiral metal shield. Position the shield on top of the other one as shown in Fig. 14-2.

Step 14-M At the “switch end” connect the white wire to lug B of strip ST5.

Step 14-N Solder (S-one) the orange wire to lug 7 on the rear deck of switch S1.

Step 14-P Solder (S-one) the yellow wire to lug 5 on the rear deck of switch S1.

Step 14-Q At the other end, Solder (S-one) yellow wire to lug A of jack J1.

Step 14-R Connect the orange wire to lug C of jack J1.

Step 14-S Solder (S-two) the white wire to lug E of J1.

Step 14-T Cut both leads of one of the 56K ohm resistors (green, blue, orange) to $\frac{3}{8}$ -inch. Connect it, as R4, between lugs B and D of J2. Solder (S-two) lug B.

Step 14-U Cut both leads of one of the 220K ohm resistors (red, red, yellow) to $\frac{1}{2}$ -inch. Connect it, as R2, between lugs C and D of J2. Solder (S-two) lug C and solder (S-two) to lug D.

Step 14-V Cut both leads of the remaining 56K ohm resistor (green, blue, orange) to $\frac{3}{8}$ -inch. Connect it, as R3, between lugs B and D of jack J1. Solder (S-two) lug B of jack J1.

Step 14-W Cut both leads of the remaining 220K ohm resistor (red, red, yellow) to $\frac{1}{2}$ -inch. Connect it, as R1, between lugs C and D of jack J1. Solder (S-two) lug C; solder (S-two) lug D.

Step 14-X This completes the shielded cable wiring and the cables must now be secured in place with the metal lugs. Bend both insulated lugs (L7 and L8) up and over the cables as shown in Fig. 14-3.

Step 14-Y The bare lug L9 near J1 will be soldered to the cables to the ground them. First tin the inside of lug L9 and both cables where the lug will touch them.

Step 14-Z Bend lug L9 up and over both cables as you did with the insulated lugs. Finally solder lug L9 to the cables as shown. As little solder (and heat) as is necessary should be used but be sure both cables are soldered.

P.S. This is a good time for a break, too!

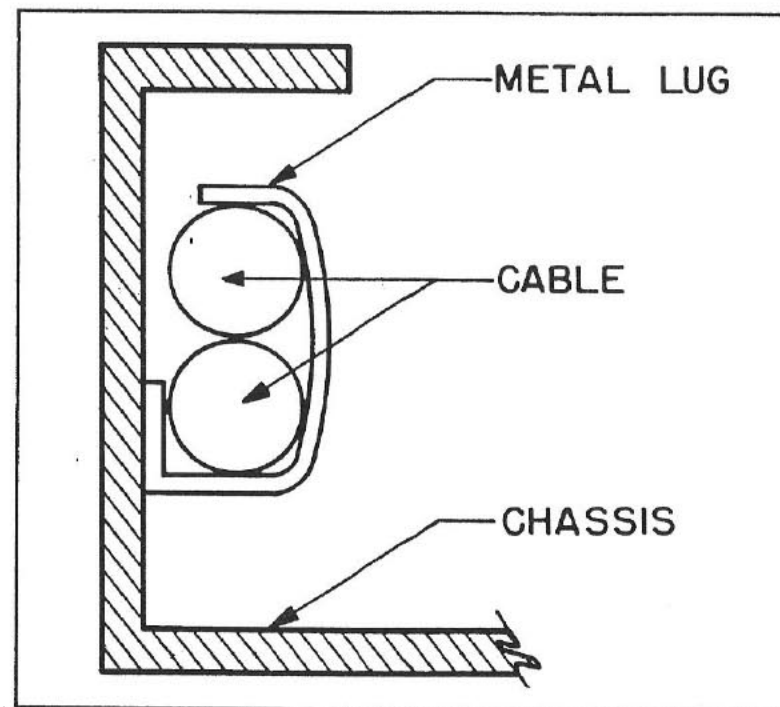

Figure 14-3

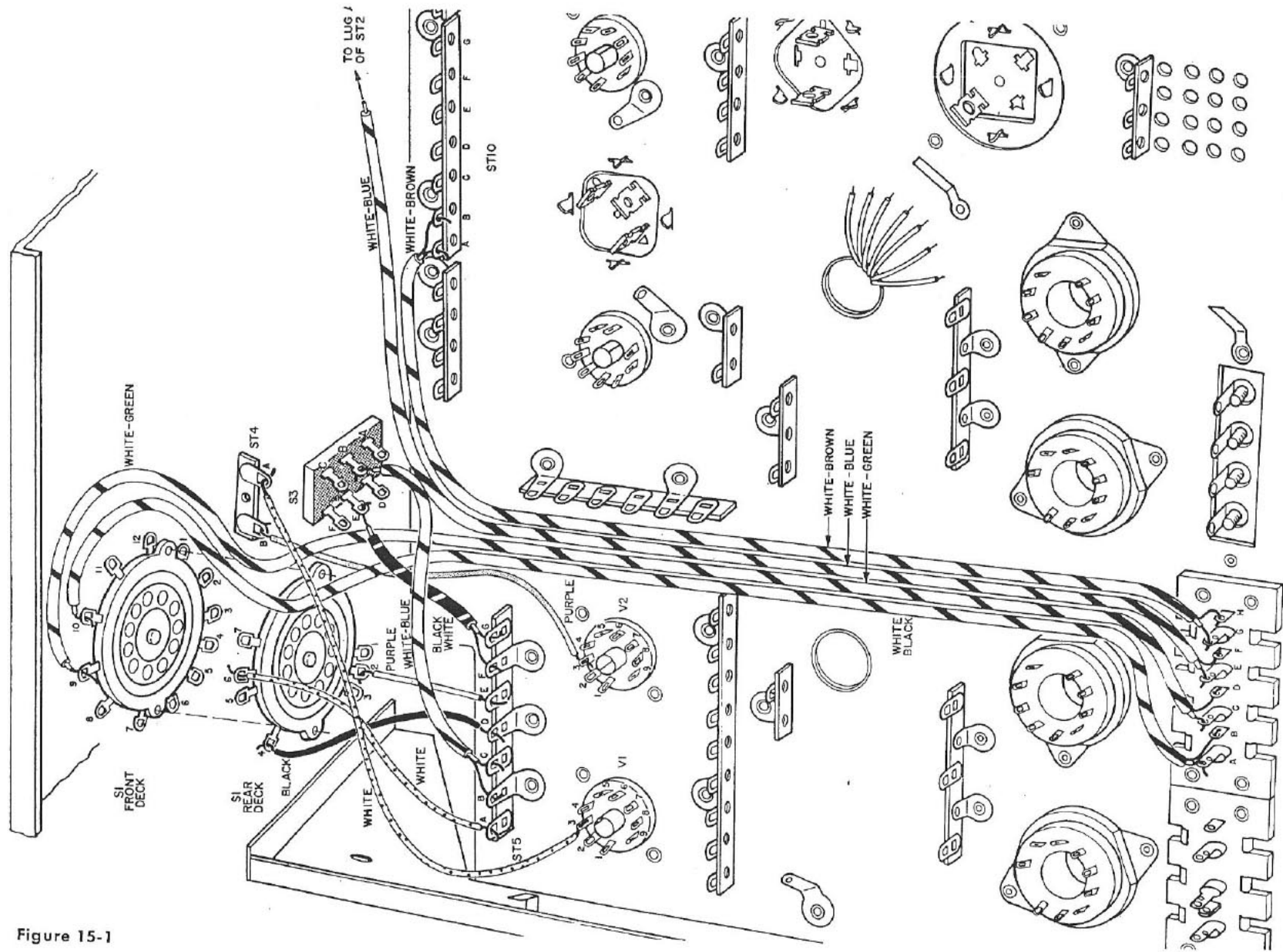

Figure 15-1

STAGE 15

YOU WILL CONTINUE in this stage to connect the front panel to the chassis. Refer to Fig. I5-1.

Step 15-A Connect the white lead from lug A of strip ST4 on the front panel to lug 3 of socket V1.

Step 15-B Connect the purple wire from lug B of strip ST4 (NOT from switch S1) on the front panel to lug 3 of socket V2.

Step 15-C Locate the white-blue shielded cable from center lug B of switch S3 on the front panel. Connect the center wire to lug C of strip ST5. Connect the ground wire to lug B of strip ST5.

Step 15-D Locate the black-white shielded cable from center lug E of switch S3. Connect the center wire to lug G of strip ST5. Connect the ground wire to lug F.

Step 15-E Now locate the purple wire connected to lug 2 on the rear deck of switch S1. Connect this wire to lug E of strip ST5.

Remove the black and the white wires from StrataPack 15.

Step 15-F Solder (S-one) one end of the white wire to lug 6 on the rear deck of switch S1. Connect the other end to lug A of strip ST5.

Step 15-G Solder (S-one) one end of the black wire to lug 4 on the rear deck of switch S1. Solder (S-one) the other end to lug D of strip ST5.

Remove the shielded cables from StrataPack 15. Strip $\frac{1}{4}$ -inch of insulation from the center wire at both ends. These cables will be run from

the front to the rear of the chassis. Keep them dressed neatly against the chassis but do not insert them under any existing wires.

Step 15-H Cut off the ground wire at one end of the white-black shielded cable. Solder (S-one) the center wire at this end to lug 10 on the front deck of switch S1.

Step 15-J Position the cable as shown over to the right and down the chassis. Solder (S-two) the ground wire to lug B of jack J3. Solder (S-one) the center wire to lug A of jack J3.

Step 15-K Cut off the ground wire at one end of the white-green shielded cable. Solder (S-one) the center wire, at this end, to lug 9 on the front deck of switch S1.

Step 15-L Position the cable in parallel with the other one. Solder (S-three) the ground wire to lug D of jack J3. Solder (S-one) the center wire to lug C of jack J3.

Step 15-M Locate the white-blue shielded cable connected to lug A of strip ST2. Position it as shown. Solder (S-three) the ground wire to lug F of jack J3. Solder (S-one) the center wire to lug E of J3.

Step 15-N Position the white-brown shielded cable (from StrataPack 15) as shown. Solder (S-two) the ground wire to lug H of J3. Solder (S-one) the center wire to lug G of J3.

Step 15-P At the other end, bend the cable over to strip ST10. Connect the center wire to lug A of ST10. Connect the ground wire to lug B (of ST10).

This completes the wiring of jack J3. Make certain the longer "hot" and shorter ground lugs are not shorted to each other by solder or bare wires.

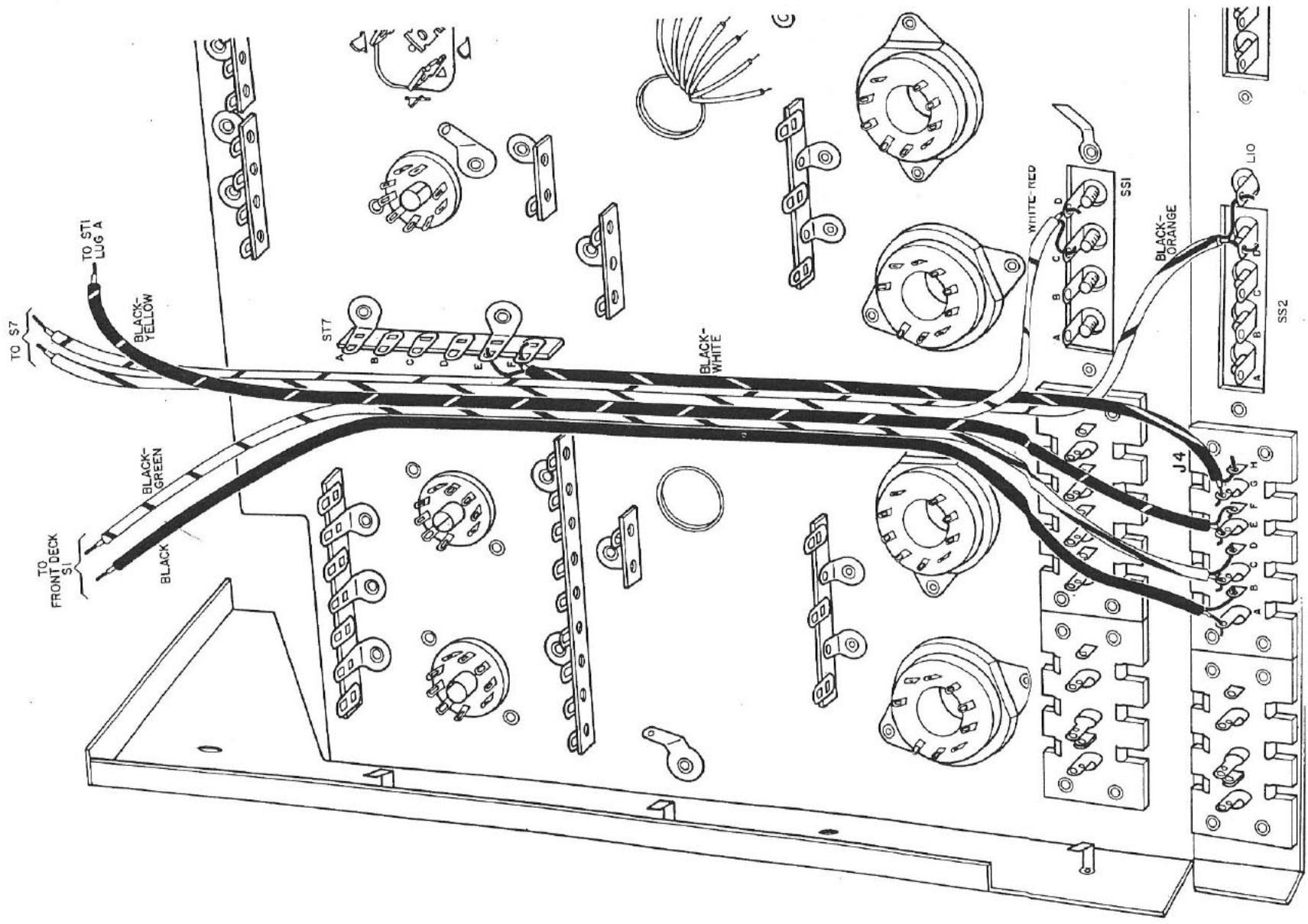

Figure 16-1

STAGE 16

ONLY ONE PART—a shielded cable—will be required for this stage. Therefore, this cable and the parts required for stages 17 and 18 have been combined in one StrataPack marked “StrataPack 16-17-18.” Open this StrataPack and remove the 7-inch black-white shielded cable. Place the StrataPack back in the carton until you complete this stage.

Strip ¼-inch insulation from the center wire at both ends of the black-white cable and then set it aside.

There are two shielded cables still connected to the front deck of switch S1. There is no need to identify the switch lugs just follow the color code. Locate the black cable. Bend it to the right and run it down the chassis parallel with the others.

Step 16-A Solder (S-two) the ground wire to lug B of jack J4. Solder (S-one) the center wire to lug A of J4.

Locate the black-green cable from the front deck of switch S1. Bend it to the right and run it down toward the rear of the chassis in parallel with the other cables.

Step 16-B Solder (S-one) the center wire to lug C of J4; solder (S-three) the ground wire to lug D of J4.

Locate the black-yellow cable connected to lug A of strip ST1 on the front panel. Bend the cable as shown and run it down to jack J4.

Step 16-C Solder (S-three) the ground wire to lug F of Jack J4. Solder (S-one) the center wire to lug E of jack J4.

Step 16-D Locate the black-white shielded cable from StrataPack 16-17-18. Solder (S-two) the ground wire to lug H of jack J4. Solder (S-one) the center wire to lug G of jack J4.

Step 16-E Position the cable as shown down to strip ST7. Connect the ground wire to lug E of ST7. Connect the center wire to lug F of ST7.

At switch S7, in the center of the front panel, there are four shielded cables. Locate the black-orange and the white-red cables and bend them over to the left and down the chassis in parallel with the other cables. Connect them as follows.

Step 16-F Solder (S-one) the center wire of the white-red cable to lug D of screw strip SS1. Solder (S-three) the ground wire to lug C of SS1.

Step 16-G Solder (S-one) the center wire of the black-orange cable to lug D of screw-strip SS2. Solder (S-two) the ground wire to lug L10.

This completes Stages 16 (and jack J4). As before, re-check your connections to the jack to make sure the longer “hot” lugs are not shorted to the shorter ground lugs.

In fact, this is a good time to stop and re-check all of your connections to these jacks—J1, J2, J3 and J4. These “close together” lugs are somewhat difficult to wire!

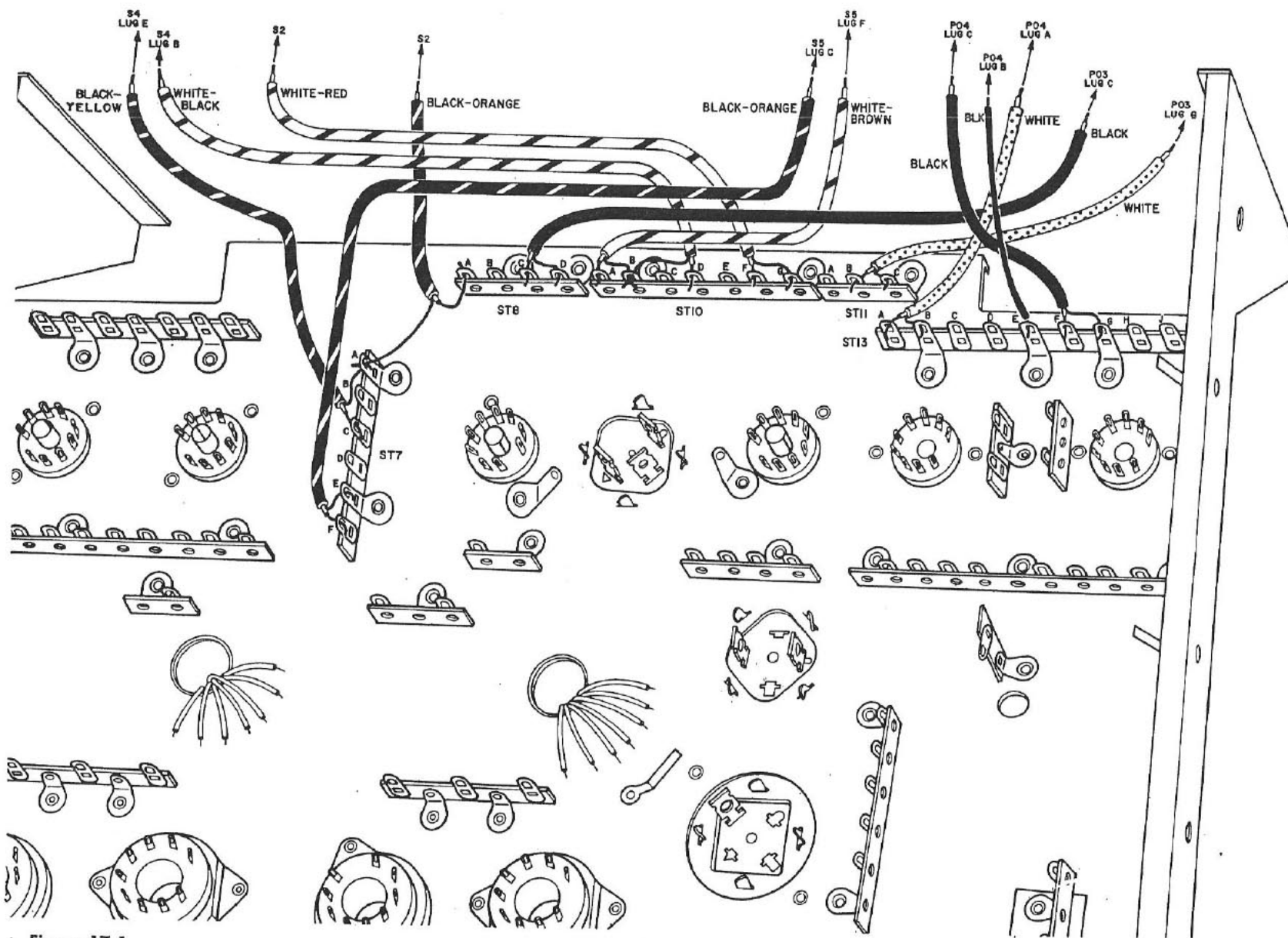

Figure 17-1

STAGE 17

AS YOU MIGHT EXPECT, you will continue to connect the front panel to the chassis.

- Step 17-A** Locate the black-orange cable from the (single deck) switch S2. Connect the ground wire to lug A of strip ST7. Connect the center wire to lug A of strip ST8.
- Step 17-B** Locate the white-red cable from switch S2. Bend it to the right and position it as shown. Connect the ground wire to lug G of strip ST10. Connect the center wire to lug F of this same strip.
- Step 17-C** Locate the black-yellow cable from lug E of switch S4. Position it as shown and connect the ground wire to lug A of strip ST7. Connect the center wire to lug C of strip ST7.
- Step 17-D** Locate the white-black wire connected to lug B of switch S4. Position it as shown and connect the ground wire to lug B of strip ST10. Connect the center wire to lug D of strip ST10.
- Step 17-E** Locate the black-orange cable from lug C of switch S5. Position it as shown and connect the ground wire to lug E of strip ST7. Connect the center wire to lug F of strip ST7.
- Step 17-F** Locate the white-brown cable from lug F of switch S5. Connect the ground wire to lug B of strip ST10. Connect the center wire to lug A of ST10.
- Step 17-G** Locate the black cable from lug C on the front section of control PO3. Position the cable as shown and connect the ground wire to lug D of strip ST8. Connect the center wire to lug C of ST8.
- Step 17-H** Locate the white cable from lug G on the rear section of control PO3. Solder (S-one) the ground wire to lug C of strip ST11. Connect the center wire to lug B of ST11.
- Step 17-J** Locate the white cable from lug A of control PO4. Connect the ground wire to lug B of strip ST13. Connect the center wire to lug A of strip ST13.
- Step 17-K** Locate the black cable from lug C of control PO4. Connect the ground wire to lug G of strip ST13. Connect the center wire to lug F of ST13.
- Step 17-L** Locate the black wire from center lug B of control PO4. Solder (S-one) it to lug E of strip ST13.

This completes stage 17. Check to be sure that all of the wires you previously connected to the front panel except those from switch S7 are now connected into the chassis. Since most of the cables are not soldered, make certain your connections are tight to prevent the wires from falling off the lugs until they are soldered.

In the next stage you will go back to "regular" wiring and soldering!

STAGE 18

YOU WILL USE two illustrations for this stage — Figures 18-1 and 18-2 on pages 43 and 44. Tear this page from your manual. Now you will wire the dual tone controls. Instead of using individual resistors and capacitors, special Fisher-designed printed circuit plates will be used to save time and insure uniformity.

The tone control printed circuits each contain 7 leads. You will first cut these leads to the correct length. Each lead will be covered with insulating spaghetti before it is soldered in place.

Locate one of the (7-lead) tone control printed circuits CP6 and cut the leads as follows:

- No. 1. 2¼-inch
- No. 2. 4½-inch
- No. 3. 1⅛-inch
- No. 4. 1⅛-inch
- No. 5. 1⅛-inch
- No. 6. 4½-inch
- No. 7. 2¼-inch

Cut three ¾-inch lengths of spaghetti. As shown in Fig. 18-1, place CP6 up against the back of the rear section of control PO1.

Step 18-A Cover lead No. 3 of CP6 with spaghetti. Solder (S-one) lead No. 3 to lug C on the front section of control PO1.

Step 18-B Cover lead No. 4 of CP6 with spaghetti. Connect lead No. 4 to center lug B on the front section of control PO1.

Step 18-C Cover lead No. 5 of CP6 with spaghetti. Solder (S-one) lead No. 5 to lug A on the front section of control PO1.

Step 18-D Cut a 2-inch length of spaghetti and slip it over lead No. 1 of CP6. Connect lead No. 1 to lug D of strip ST8.

Step 18-E Cut a 4¼-inch length of spaghetti and slip it over lead No. 2 of CP6. Position lead No. 2 exactly as shown and solder (S-one) it to lug C on the front section of control PO2.

Step 18-F Cut a 4¼-inch length of spaghetti and slip it over lead No. 6 of CP6. Position lead No. 6 exactly as shown and solder (S-one) it to lug A on the front section of control PO2.

Step 18-G Cut a 2-inch length of spaghetti and slip it over lead No. 7 of CP6. Turn over the chassis and solder (S-two) lead No. 7 to lug A of strip ST3 on the front panel.

Step 18-H Solder (S-one) one end of the shorter purple wire (from StrataPack 16-17-18) to center lug B on the front section of control PO2. Position the wire as shown and connect the other end to lug B on the front section of control PO1.

Step 18-J Solder (S-three) one end of the remaining purple wire to center lug B on the front section of PO1.

Step 18-K Position the purple lead as shown, dressed down against the chassis. Solder (S-one) the other end to lug 7 of socket V3.

Locate the other 7-lead tone-control printed circuit CP5 and cut the leads as follows:

- No. 1. 2¼-inch
- No. 2. ½-inch
- No. 3. 4-inch
- No. 4. ½-inch
- No. 5. 3¾-inch
- No. 6. ½-inch
- No. 7. 3¾-inch

Position CP5 on the back of control PO2 as shown in Fig. 18-2, and

Figure 18-1

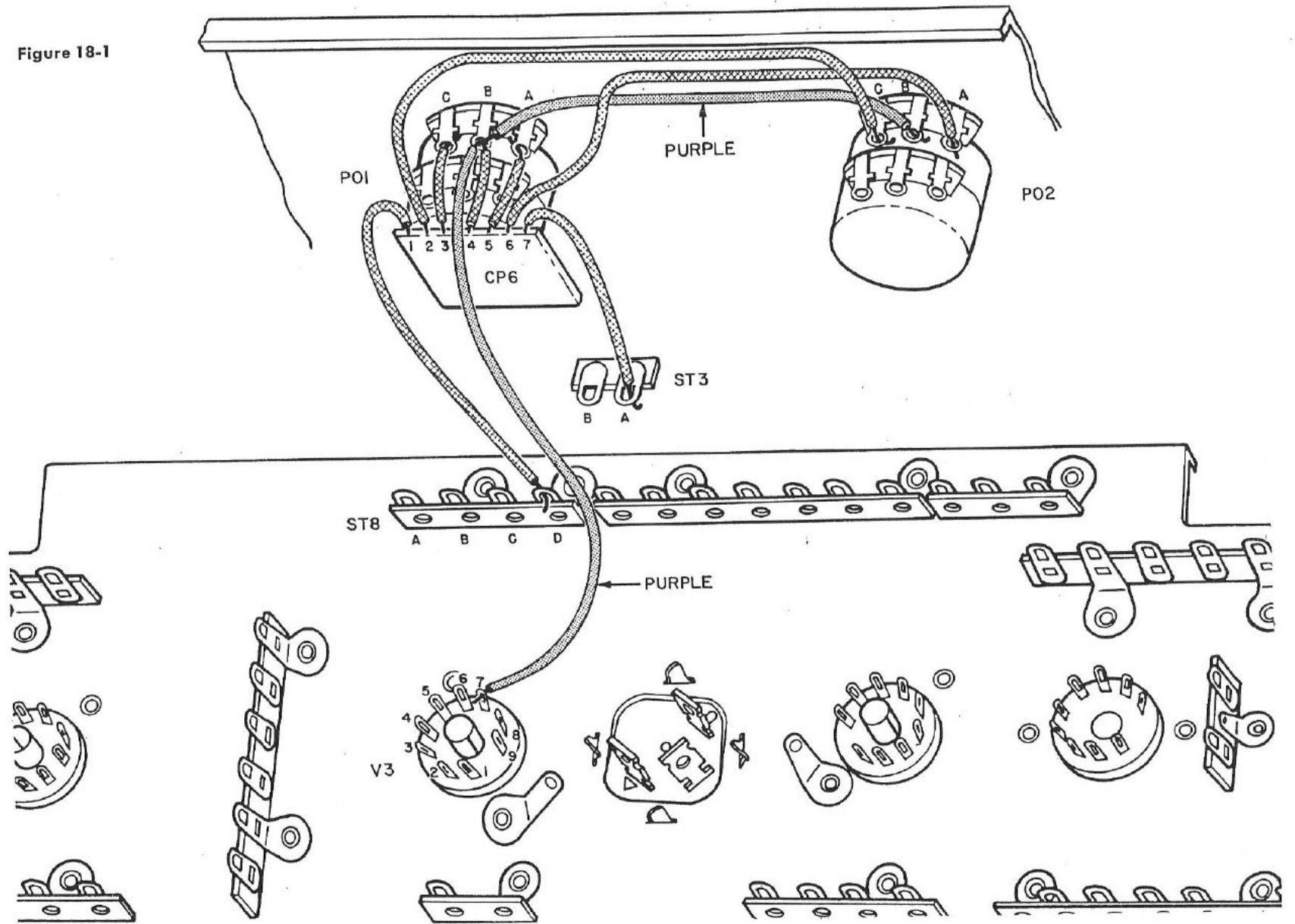

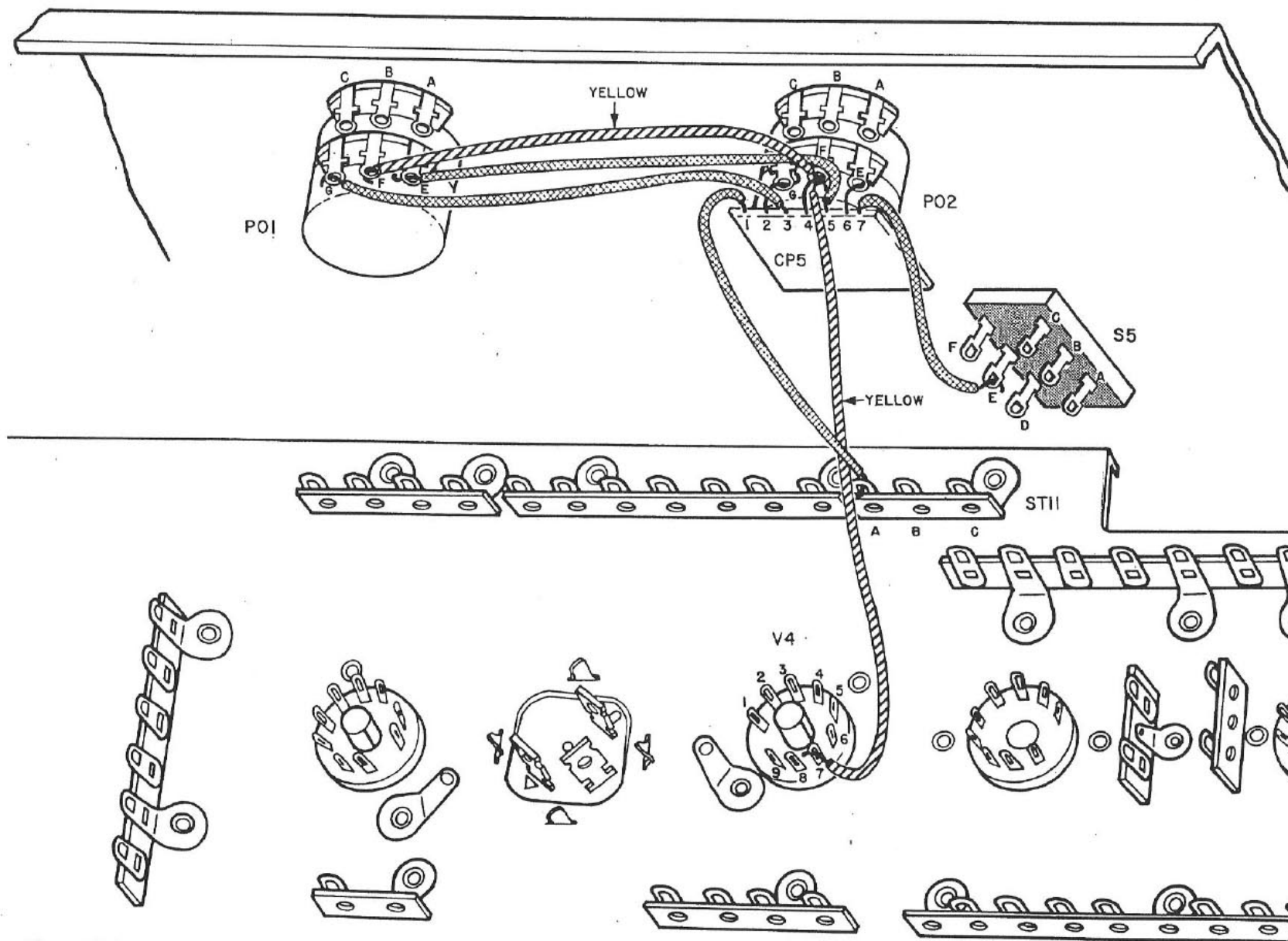

Figure 18-2

wire it as follows with the insulating spaghetti, where required, as you did before.

Step 18-L Solder (S-one) lead No. 2 to lug G on the rear section of control PO2.



Step 18-M Connect lead No. 4 to lug F on the rear section control PO2.



Step 18-N Solder (S-one) lead No. 6 to lug E on the rear section of control PO2.



Step 18-P Cut a 1 $\frac{3}{4}$ -inch length of spaghetti and slip it over lead No. 1 of CP5. Connect lead No. 1 to lug A of strip ST11.



Step 18-Q Cut a 3 $\frac{3}{4}$ -inch length of spaghetti and slip it over lead No. 3 of CP5. Position lead No. 3 as shown and solder it (S-one) to lug G on the rear section of control PO1.



Step 18-R Cut a 3 $\frac{1}{2}$ -inch length of spaghetti and slip it over lead No. 5 of CP5. Position lead No. 5 as shown and solder it (S-one) to lug E on the rear section of control PO1.



Step 18-S Cut a 3 $\frac{1}{2}$ -inch length of spaghetti and slip it over lead No. 7 of CP5. Turn over the chassis and solder (S-one) lead No. 7 to center lug E of switch S5.



Step 18-T Solder (S-one) one end of the shorter yellow wire to center lug F on the rear section control PO1. Position the wire as shown and connect the other end to center lug F on the rear section of control PO2.



Step 18-U Solder (S-three) one end of the remaining yellow wire to center lug F on the rear section of control PO2.



Step 18-V Position the yellow wire as shown, dressed down against the chassis. Solder (S-one) the end to lug 7 of socket V4.



This completes the wiring of the tone-controls. As can be seen in the schematic, each printed circuit (CP5 and CP6) contains six separate components. Thus, the use of printed circuits did save a number of connections! Before continuing it would be well to check the stage as follows:

Step 18-W Examine CP5—make sure the spaghetti is pushed up against CP5 to prevent the number leads from shorting to each other.



Step 18-X Examine CP6— as above, be sure the spaghetti fully covers the leads at the printed circuits.



Step 18-Y Make certain your connections at sockets V3 and V4 are correct— check the lug numbers again.



And since there's only one letter left . . .

Step 18-Z Be sure the leads between the two tone controls are positioned as shown—the channel B leads up toward the front panel and the channel A leads kept away from the panel (and jack J5).



Figure 19-1

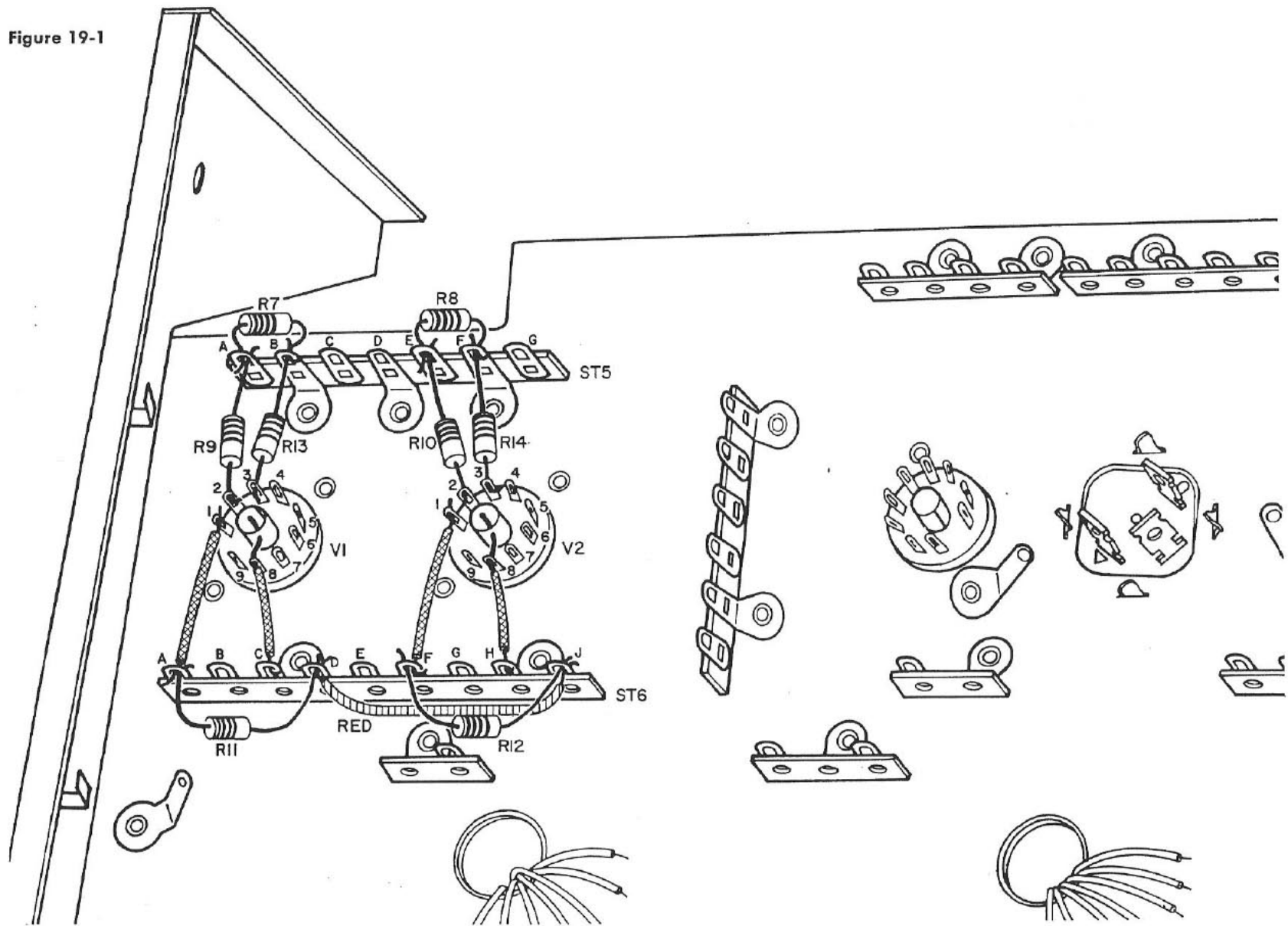

STAGE 19

IN THIS STAGE you will begin to wire the low-level preamplifier stages V1 and V2. Wire these high gain stages carefully.

Step 19-A Cut two 1½-inch lengths of bare wire and two ⅝-inch lengths of spaghetti.

Step 19-B Insert one bare wire through lug 8 of V1 and into the circular shield in the center of the socket. Slip the spaghetti over the free end of the wire and connect it to lug C of strip ST6. Solder (S-one) the shield and solder (S-one) lug 8.

Step 19-C Insert the other bare wire through lug 8 of V2 and into the circular shield. Slip the spaghetti over the free end of the wire and connect it to lug H of strip ST6. Solder (S-one) the shield and solder (S-one) lug 8.

Step 19-D Connect the red wire from lug J to lug D of strip ST6.

There are four glass resistors in StrataPack 19. These are special low noise units but their construction is such that the color code may be difficult to read. However, they are rated at 1 watt and are physically larger than the other resistors in the pack. Locate them and examine them carefully to determine the color-code.

Step 19-E Locate the two 330K ohm (orange, orange, yellow) glass resistors and cut all four leads (of both) to ¾-inch. Connect one 330K ohm resistor (R11), between lugs A and D of strip ST6.

Step 19-F Connect the other 330K ohm resistor, R12, between lugs F and J of strip ST6.

Step 19-G Locate the two 2.2K ohm (red, red, red) glass resistors and cut all four leads to ⅝-inch. Connect one of the 2.2K ohm resistors, R13, between lug 3 of socket V1 and lug B of strip ST5.

Step 19-H Connect the other 2.2K ohm resistor, R14, between lug 3 of socket V2 and lug F of strip ST5.

Step 19-J Cut all (four) leads on both 10K ohm resistors (brown, black, orange) to ½-inch. Connect one, R9, between lug 2 of socket V1 and lug A of strip ST5.

Step 19-K Connect the other 10K ohm resistor, R10, between lug 2 of socket V2 and lug E of strip ST5.

Step 19-L Cut all (four) leads of both 56K ohm resistors (green, blue, orange) to ⅜-inch. Connect one, R7, between lugs A and B of strip ST5.

Step 19-M Connect the other, R8, between lugs E and F of strip ST5.

Step 19-N Solder the following connections:

- Solder (S-one) lug 2 of socket V1.
- Solder (S-two) lug 3 of socket V1.
- Solder (S-one) lug 2 of socket V2.
- Solder (S-two) lug 3 of socket V2.
- Solder (S-three) lug A of strip ST5.
- Solder (S-four) lug B of strip ST5.
- Solder (S-three) lug E of strip ST5.
- Solder (S-four) lug F of strip ST5.

Step 19-P Cut two 1⅝-inch lengths of bare wire and two 1-inch lengths of spaghetti.

Step 19-Q Solder (S-one) one end of one wire to lug 1 of socket V1. Slip the spaghetti over the wire and connect the other end to lug A of strip ST6.

Step 19-R Solder (S-one) one end of the other wire to lug 1 of socket V2. Slip the spaghetti over the wire and connect the other end to lug F of strip ST6.

Step 19-S Check to be sure the resistors are installed properly.

Figure 20-1

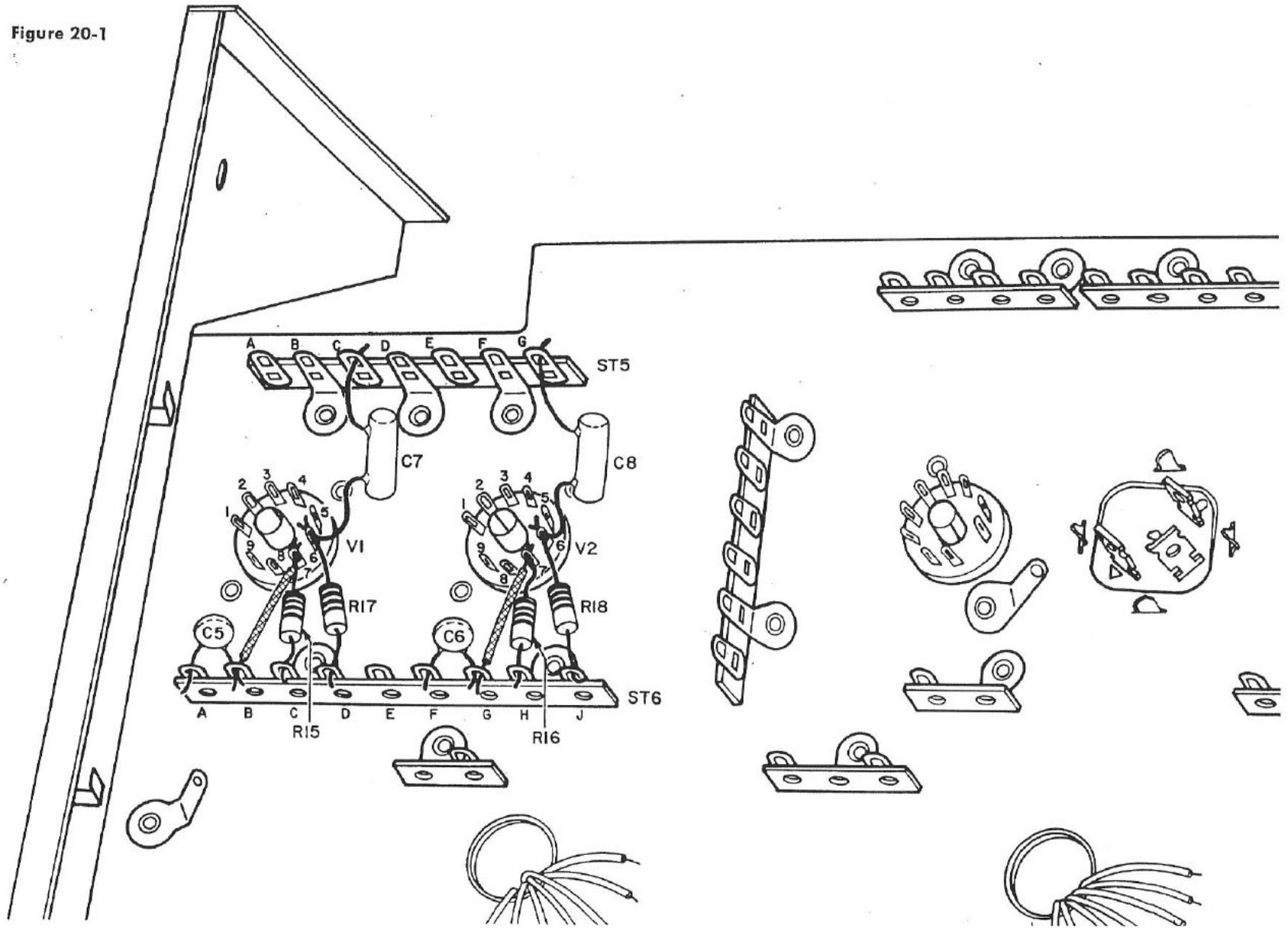

STAGE 20

IN THIS STAGE you will complete the wiring of the preamplifier stages. Again we caution you to keep your wiring neat.

Step 20-A Cut two 1¼-inch bare wires and two ¾-inch lengths of spaghetti.

Step 20-B Connect one wire to lug 7 of socket V1. Slip the spaghetti over the wire and connect the other end to lug B of ST6.

Step 20-C Connect the other wire to lug 7 of socket V2. Slip the spaghetti over the wire and connect the other end to lug G of strip ST6.

Step 20-D Cut all (four) leads on both 2.2 megohm resistors (red, red, green) to ¾-inch.

Step 20-E Connect one, R15, between lug 7 of socket V1 and lug C of strip ST6. Solder (S-two) lug 7 of V1; solder (S-two) lug C of ST6.

Step 20-F Connect the other, R16, between lug 7 of socket V2 and lug H of strip ST6. Solder (S-two) lug 7 of V2; solder (S-two) lug H of ST6.

Step 20-G Cut all (four) leads on both .01 mfd disc capacitors to ½-inch. Connect one, as C5, between lugs A and B of strip ST6. Solder (S-three) lug A; solder (S-two) lug B.

Step 20-H Connect the other, C6, between lugs F and G of strip ST6. Solder (S-three) lug F; solder (S-two) lug G.

Step 20-J Cut all (four) leads on both 220K ohm resistors (red, red, yellow) to ½-inch.

Step 20-K Connect one resistor, R17, between lug 6 of socket V1 and lug D of strip ST6. Solder (S-three) lug D of ST6.

Step 20-L Connect the other resistor, R18, between lug 6 of socket V2 and lug J of strip ST6. Solder (S-four) lug J of ST6.

Step 20-M Cut all (four) leads on both .022 mfd mylar capacitors to ¾-inch.

Step 20-N Connect one, C7, between lug 6 of socket V1 and lug C of strip ST5. Solder (S-two) lug 6 of V1; solder (S-two) lug C of strip ST5.

Step 20-P Connect the other, C8, between lug 6 of socket V2 and lug G of strip ST5. Solder (S-two) lug 6 and solder (S-two) lug G.

Step 20-Q Check strip ST5: all lugs should be connected and soldered. Check strip ST6: all lugs, except lug E, should be connected and soldered.

Step 20-R Check sockets V1 and V2: all lugs, except lug 9, should be connected and soldered.

The program sources (record player, FM tuner, etc.) that you will use with your KX-100 can be classified as either low level or high level signal devices. Most tuners, for example, are high level since the output signal can be expected to be from 500 mv (½ volt) to 2 volts.

Magnetic phono cartridges and tape recorder heads, however, have much lower output — from 2.0 to 10 mv (.002 to .01 volt). These signals require extra amplification and this is the job of stages V1 and V2.

In addition, the signal output from these cartridges and tape heads does not have a flat frequency response because of the necessary recording techniques. In general the bass (low frequencies) are reduced while the high end is emphasized during recording. Another task of stages V1 and V2, then, is to “equalize” this signal by boosting the bass and reducing the highs to provide a “flat” response. Since the amount of bass cut and high boost is different for disc and tape recording, two different switch-selected equalizations are provided.

Figure 21-1

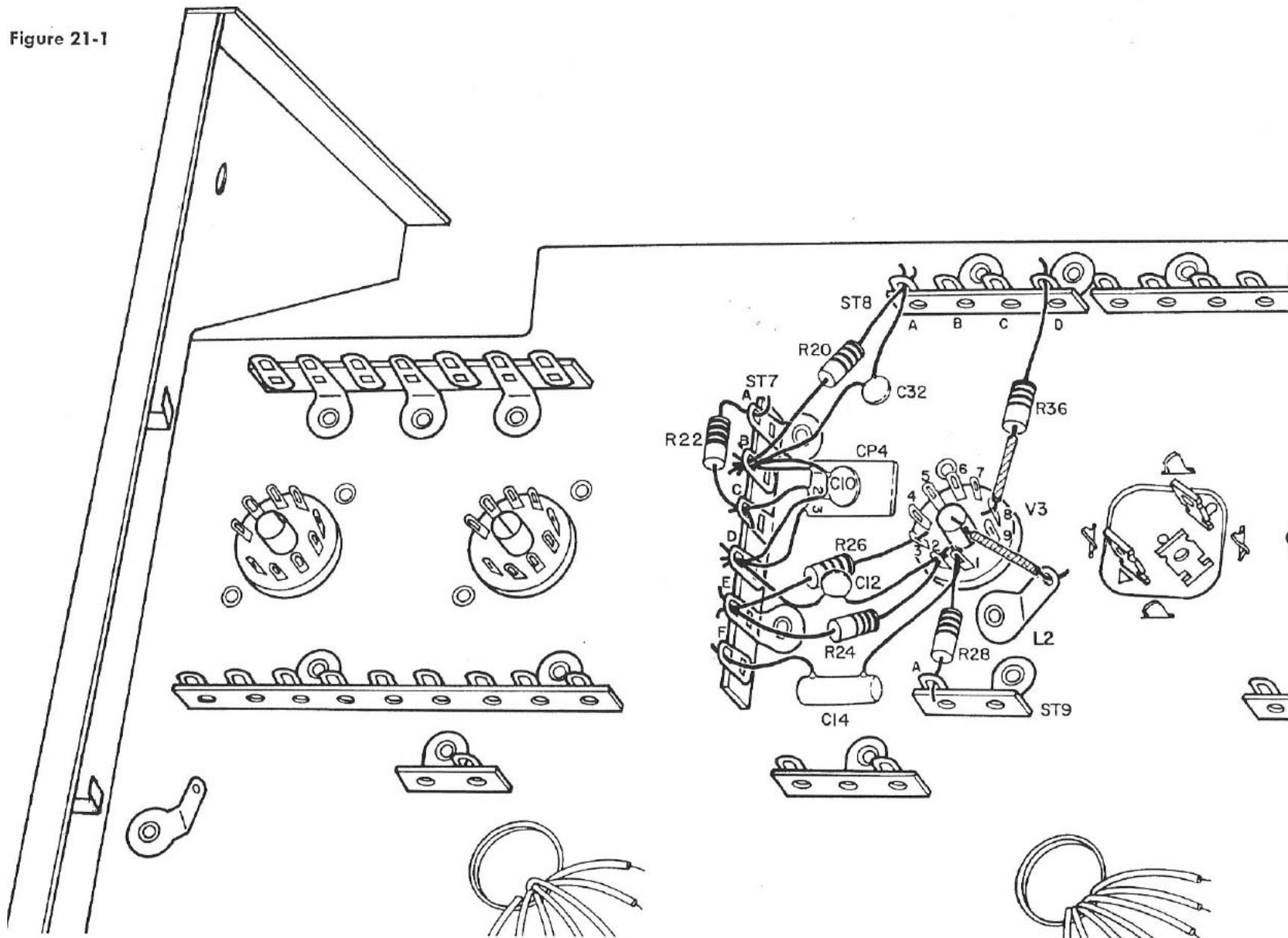

STAGE 21

YOU WILL now wire tone-control amplifier stage V3 in channel B.

Step 21-A Cut a 1¼-inch bare wire and a ⅝-inch length of spaghetti. Solder (S-one) end of the wire to the center shield of socket V3. Slip the spaghetti over the wire and solder (S-one) the other end to lug L2.

Step 21-B Cut both leads of one of the 2.2K ohm resistors (red, red, red), R36, to 1⅛-inch. Cut a ¾-inch length of spaghetti. Slip the spaghetti over one lead and solder (S-one) this lead to lug 8 of V3. Solder (S-three) the other lead to lug D of strip ST8.

Step 21-C Cut both leads of the remaining 2.2K ohm resistor, R26, to ½-inch. Connect R26 between lug 3 of socket V3 and lug E of strip ST7. Solder (S-one) lug 3 of V3.

Step 21-D Cut both leads of the 2.2 megohm resistor (red, red, green), R24, to ½-inch. Connect R24 from lug 2 of V3 to lug E of strip ST7. Solder (S-four) lug E of ST7.

Step 21-E Cut both leads of the 680 mmf disc capacitor to ⅝-inch. Connect it, as C12, from lug 2 of V3 to lug D of strip ST7. Solder (S-two) lug 2 of V3.

Step 21-F Cut the 3-leads of the high filter printed circuit CP4 as follows:

- Lead No. 1. ⅝-inch
- Lead No. 2. ½-inch
- Lead No. 3. ⅝-inch

Step 21-G Connect CP4 to strip ST7 as shown:

- Lead No. 1. to lug B
- Lead No. 2. to lug C
- Lead No. 3. to lug D

Step 21-H Cut both leads of the 68 mmf disc capacitor, C10, to ⅝-inch. Connect C10 from lug B of strip ST7 to lug D of ST7. Solder (S-three) lug D.

Step 21-J Cut both leads of the 560K ohm resistor (green, blue, yellow) to ¾-inch. Connect it, as R20, between lug B of strip ST7 and lug A of strip ST8.

Step 21-K Cut both leads of the 10 mmf disc capacitor to ¾-inch. Connect it, as C32, in parallel with R20 between lug B of strip ST7 and lug A of strip ST8. Solder (S-three) lug A of strip ST8.

Step 21-L Cut both leads of the 10 megohm resistor (brown, black, blue) to ½-inch. Connect it, as R22, between lugs A and C of strip ST7. Solder (S-three) lug A of strip ST7. Solder (S-three) lug C of strip ST7.

Step 21-M Cut both leads of the 82K ohm resistor (grey, red, orange) to ½-inch. Connect it, as R28, between lug 1 of V3 and lug A of strip ST9. Solder (S-three) lug A of strip ST9.

Step 21-N Cut both leads of the .022 mfd mylar capacitor to ⅝-inch. Connect it, as C14, from lug 1 of socket V3 to lug F of strip ST7. Solder (S-two) lug 1 of socket V3.

The special Fisher-engineered high filter printed circuit, CP4, contains five separate components, as can be seen in the schematic diagram. With the high filter switch turned on, this printed circuit, acting with other components in stage V3, reduces the high frequency response of the stage, beginning at 5000 cps. Thus, annoying noise from old records or distant radio stations can be reduced without removing the entire high frequency content.

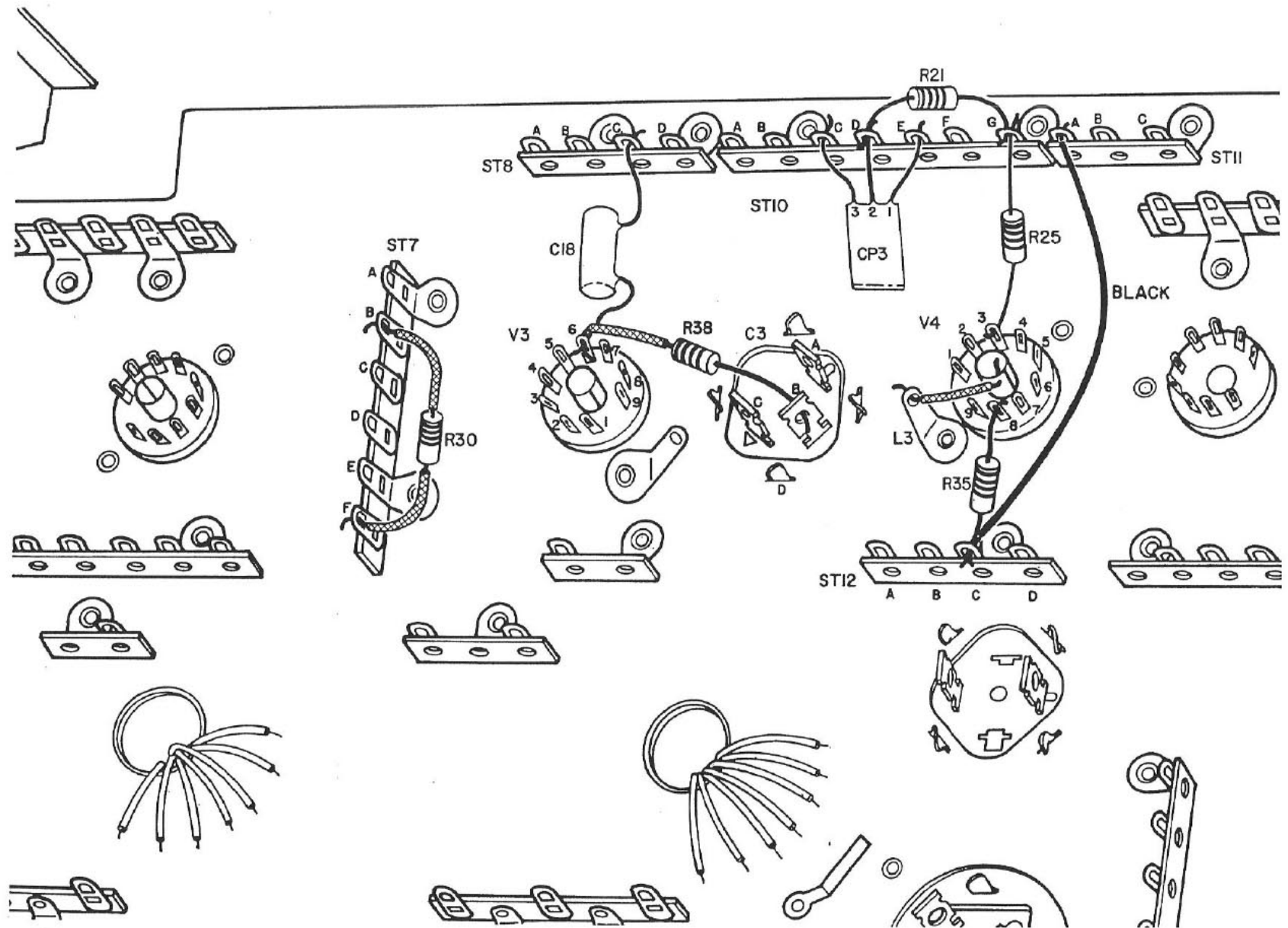

Figure 22-1

STAGE 22

YOU WILL COMPLETE the wiring of tone control stage V3 in channel B and begin wiring the tone control stage for channel A.

Step 22-A Cut both leads of the 1 megohm resistor (brown, black, green) to $\frac{7}{8}$ -inch. Cut two $\frac{1}{2}$ -inch lengths of spaghetti. Slip the spaghetti over the resistor leads and connect it, as R30, between lugs B and F of strip ST7. Solder (S-five) lug B and solder (S-four) lug F.

Before continuing, carefully examine strip ST7. There are many parts connected here — be sure you do not have any unwanted shorts between these part leads. In particular . . .

Step 22-B There are five leads soldered to lug B of strip ST7. Be sure this is a good soldered joint — gently tug on these leads. If any are loose, resolder the joint.

Step 22-C Check to be sure the ground wires on the shielded cables are not accidentally shorted to other lugs on ST7.

Continue wiring as follows.

Step 22-D Cut both leads of the 82K ohm resistor R38, (grey, red, orange) to $\frac{3}{4}$ -inch. Cut a $\frac{1}{2}$ -inch length of spaghetti. Slip the spaghetti over one lead and connect it to lug 6 of V3. Connect the other lead to lug B of capacitor C3.

Step 22-E Cut both leads of the .047 mfd mylar capacitor to $\frac{3}{4}$ -inch. Connect it, as C18, between lug 6 of socket V3 and lug C of strip ST8. Solder (S-two) lug 6 of V3. Solder (S-two) lug C of strip ST8. Position the capacitor exactly as shown.

This completes the wiring of stage V3. All of the lugs, except lug 9, of socket V3 should be connected to and soldered.

Step 22-F Cut a 1-inch bare wire and a $\frac{5}{8}$ -inch length of spaghetti. Solder (S-one) one end of the wire to the circular center shield of socket V4. Slip the spaghetti over the wire and solder (S-one) it to lug L3.

Step 22-G Cut both leads of the 2.2K ohm resistor (red, red, red) to $\frac{7}{8}$ -inch. Connect it, as R25, from lug 3 of socket V4 to lug G of strip ST10. Solder (S-one) lug 3 of V4.

Step 22-H Cut the leads of the high filter printed circuit as follows:

- Lead No. 1. $\frac{5}{8}$ -inch
 Lead No. 2. $\frac{1}{2}$ -inch
 Lead No. 3. $\frac{5}{8}$ -inch

Step 22-J Connect the printed circuit, CP3, as shown with lead No. 1 to lug E of strip ST10, lead No. 2 to lug D of ST10 and lead No. 3 to lug C of ST10.

Step 22-K Cut both leads of the 10 megohm resistor (brown, black, blue) to $\frac{3}{4}$ -inch. Connect it, as R21, between lugs D and G of strip ST10. Solder (S-three) lug D of ST10. Solder (S-three) lug G of strip ST10.

Step 22-L Connect the black wire from lug A of strip ST11 to lug C of strip ST12. Solder (S-two) lug A of strip ST11.

Step 22-M Cut both leads of the remaining 2.2K ohm resistor (red, red, red) to $\frac{3}{8}$ -inch. Connect it, as R35, from lug 8 of V4 to lug C of strip ST12. Solder (S-one) lug 8 of socket V4 and solder (S-two) lug C of ST12.

Time to recheck your soldering iron? If it doesn't have a permanent (plated) tip, does it need refiling and tinning? Even plated tips eventually become pitted and require replacement. Can't solder properly with a poor iron!

Figure 23-1

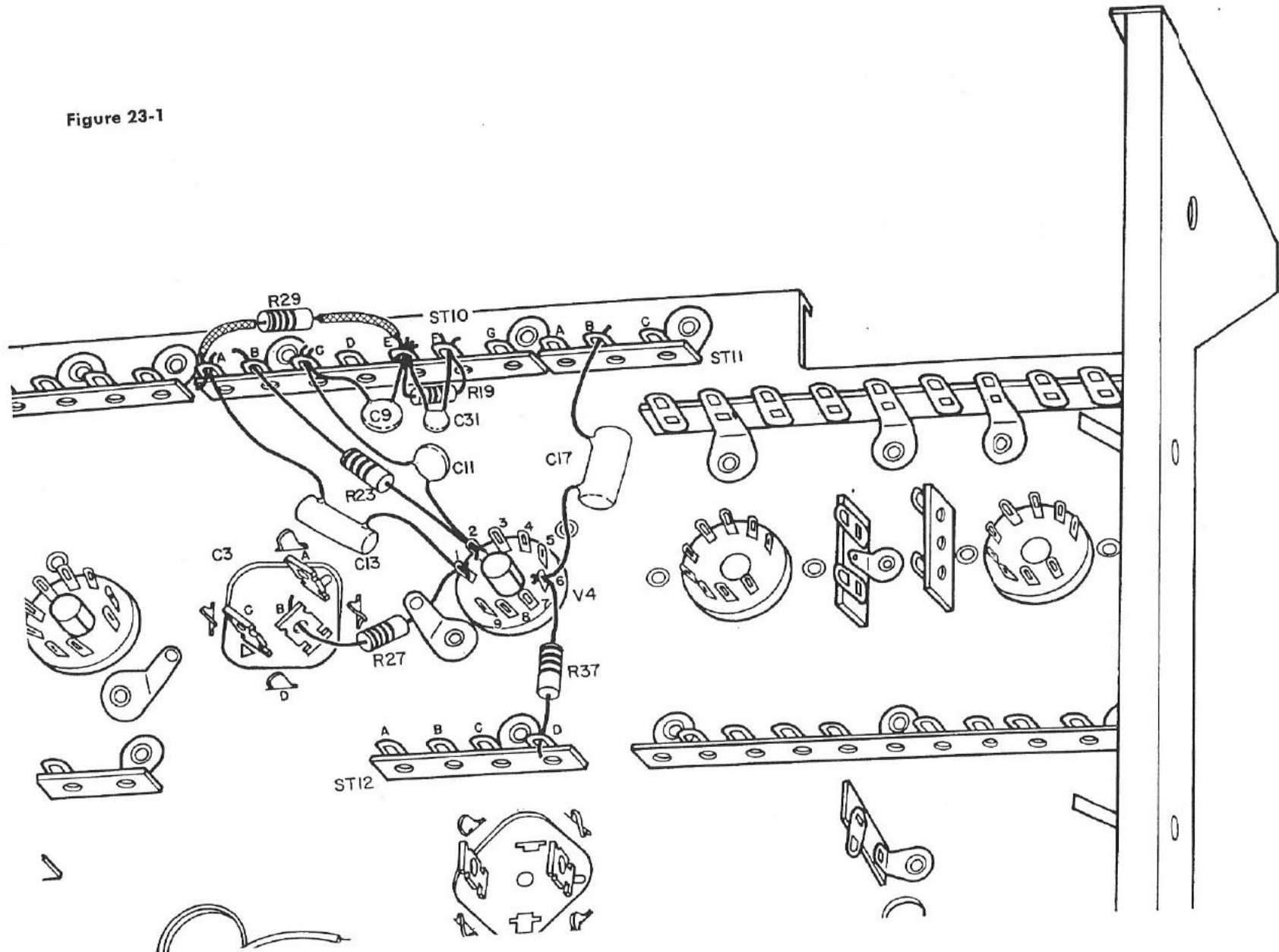

STAGE 23

THE TONE CONTROL stage V4 for channel A will now be completed.

- Step 23-A** Cut both leads of one of the 82K ohm resistors, R27, (grey, red, orange) to 1/2-inch. Bend the resistor leads as shown and connect R27 from lug 1 of socket V4 to lug B of capacitor C3. Solder (S-three) lug B of capacitor C3.
- Step 23-B** Cut both leads of the .022 mfd mylar capacitor to 1 1/8-inch. Connect it, as C13, from lug 1 of socket V4 to lug A of strip ST10. Solder (S-two) lug 1 of V4.
- Step 23-C** Cut both leads of the 1 megohm resistor, R29, (brown, black, green) to 1-inch. Cut two 7/8-inch lengths of spaghetti.
- Step 23-D** Slip the spaghetti over the leads of resistor R29 and bend them as shown. Connect R29 between lugs A and E of strip ST10. Solder (S-four) lug A of strip ST10.
- Step 23-E** Cut both leads of the 2.2 megohm resistor, R23, (red, red, green) to 1-inch. Connect R23, from lug 2 of socket V4 to lug B of strip ST10. Solder (S-four) lug B of strip ST10.
- Step 23-F** Cut both leads of the 680 mmf disc capacitor, C11 to 1 1/8-inch. Connect C11 from lug 2 of socket V4 to lug C of strip ST10. Solder (S-two) lug 2 of socket V4.
- Step 23-G** Cut both leads of the 68 mmf disc capacitor C9 to 1/2-inch. Connect C9 between lugs C and E of strip ST10. Solder (S-three) lug C of strip ST10.
- Step 23-H** Cut both leads of the 560K ohm resistor R19 (green, blue, yellow) to 1/2-inch. Connect R19 between lugs E and F of strip ST10.
- Step 23-J** Cut both leads of the 10 mmf disc capacitor C31 to 1/2-inch. Connect C31, in parallel with R19, between lugs E and F of strip ST10. Solder (S-five) lug E; solder (S-three) lug F.
- Step 23-K** Cut both leads of the remaining 82K ohm resistor R37, (grey, red, orange) to 1/2-inch. Connect R37 from lug 6 of socket V4 to lug D of strip ST12. Solder (S-two) lug D of strip ST12.
- Step 23-L** Cut both leads of the .047 mfd mylar capacitor C17 to 1-inch. Connect C17 from lug 6 of socket V4 to lug B of strip ST11. Solder (S-two) lug 6 of V4; solder (S-two) lug B of strip ST11.

This completes stage V4. Before continuing, it would be well to check as follows:

- Step 23-M** All lugs on strip ST10 are connected to and soldered. Particularly check lug E which have five leads — tug on the leads as before and re-solder, if necessary.
- Step 23-N** Be sure none of the ground wires of the shielded cables at strip ST10 are causing shorts.
- Step 23-P** All of the lugs, except lug 9, of socket V4 are connected to and soldered.

Although it may seem that your chassis is almost completed, there is still quite a bit left. So don't hurry — you can't finish the remaining stages "Tonight". Take a break!

STAGE 24

SOME LONG WIRES will be connected from one corner of the chassis to the other. These connections and others for this stage are shown on the separate sheet as Figure 24-1.

First you will wire the AC ON-OFF switch, S8, on volume control PO3 and the pilot lamp socket, SO1. The wires to both of these will be run through the spiral metal shields as shown. Locate both spiral shields, open StrataPack 24 and proceed as follows:

Insert the black and white glass wires in the shorter spiral shield. Position the shield on lugs L11, L12, and L13 on the right edge of the chassis shown. Note that the shield projects about 1/2-inch past lug L13 at the rear of the chassis.

At the other end of the cable, remove enough insulation from both the black and white wires until you have about 1-inch of bare wire.

Step 24-A Remove the disc-like insulator from StrataPack 24. Place it on switch S8 (on PO3) with the switch lugs projecting through the insulator. Note that it will fit only one way because of the lug spacing.

Step 24-B Insert the white wire through lug A, up to and through lug B. At lug B, bend over the wire and cut off any excess.

Step 24-C Insert the black wire through lug C, up to and through lug D. At lug D, bend over the wire and cut off any excess.

Step 24-D The above are the only connections to switch S8. Solder all four lugs. Locate the cup-shaped AC switch shield. This will be placed over the back of the volume control to cover the 4-lug switch. Note that there is a slot in the shield for the two wires. Solder the shield to the case of the switch to hold it in place as shown in Fig. 24-2.

Step 24-E At the other end of the cable, solder (S-two) the black wire to lug A of the fusepost.

Step 24-F Solder (S-two) the white wire to lug B of strip ST17.

Next you will wire the pilot lamp socket SO1 on the front panel. Note in Fig. 24-1 that the wires for SO1 are inserted in a spiral cable that is positioned on the right edge of the chassis and runs up on the front, top chassis edge.

Step 24-G Insert the green and yellow glass wires in the remaining spiral shield. The wires will project from both ends.

Turn over the chassis with the front panel away from you. Place the cable along the front edge of the chassis with the end projecting about 1/2-inch past lug L15. Bend lugs L15 and L14 over the cable to hold it in place.

Step 24-H Solder both lugs L14 and L15 to the cable.

Step 24-J Twist together (two or three twists) the yellow and green wires and connect them to socket SO1. Solder (S-one) the green wire to lug B; solder (S-one) the yellow wire to lug A.

At the left side, push the cable down under the chassis near the volume control (PO3) and turn over the chassis. Position the cable along the right edge, on top of the other cable as shown in Figure 24-1. Bend lugs L11, L12 and L13 up over the cables to hold them in place.

Step 24-K Solder lug L12 to both cables.

Gently pull the free ends of the yellow and green wires so there is no slack at the other end where they are connected to socket SO1. Bend the wires over toward strip ST16 and twist them together. Cut them shorter, if necessary, and remove ¼-inch insulation from the ends.

Step 24-L Solder (S-four) the green wire to lug C of strip ST16.



Step 24-M Solder (S-four) the yellow wire to lug D of strip ST16. Dress the wires down on the chassis.



You will now run some long wires from stages V5 and V6 to output stages. Position these wires exactly as shown here and dress them down right on the chassis.

Step 24-N Connect one end of the orange wire to lug H of strip ST13. Solder (S-two) the other end to lug B of strip ST21.



Step 24-P Connect one end of the blue wire to lug C of strip ST13. Solder (S-three) the other end to lug A of strip ST21.



Step 24-Q Connect one end of the green wire to lug A of strip ST14. Bend the wire to the left over to the group of cables running from the front panel to the rear of the chassis. Position the green wire *underneath* this group of cables positioned as shown. Solder (S-three) the other end to lug A of strip ST18.



Step 24-R Connect one end of the purple wire to lug D of strip ST14. Run this wire parallel with the green one. Solder (S-three) the other end to lug C of strip ST18.



Step 24-S Connect one end of the brown wire to lug E of strip ST14. Run this wire as shown, down to strip ST19. Solder (S-three) the free end to lug A of strip ST19.



Step 24-T Connect one end of the yellow wire to lug H of strip ST14. Run this wire as shown and solder (S-three) the end to lug C of strip ST19.



This completes the wiring for Stage 24. Be sure you positioned these long wires exactly as shown and dressed down against the chassis.

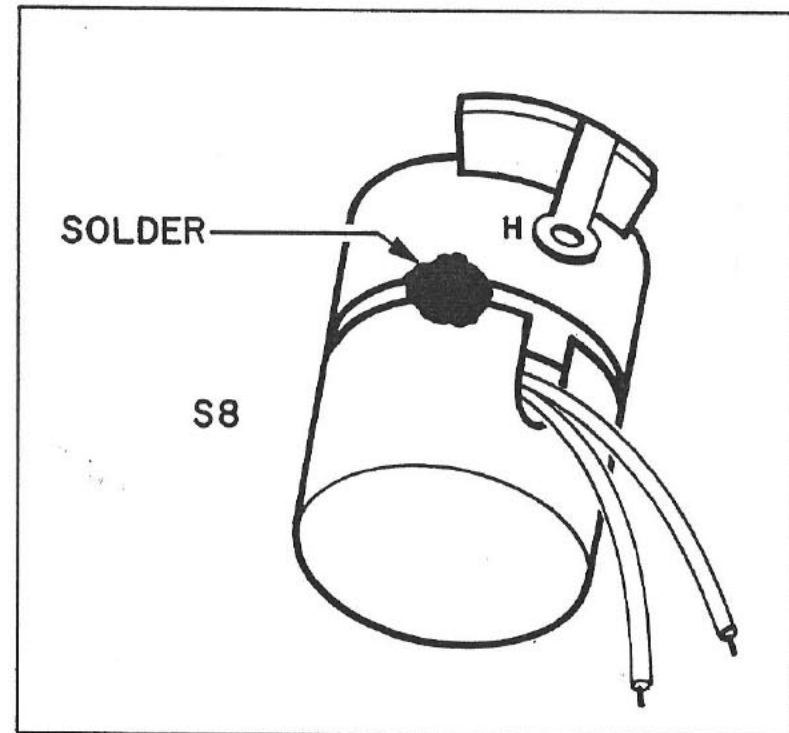

Figure 24-2

STAGE 25

IN THIS STAGE you will begin the wiring of Stages V5 and V6.

- Step 25-A** Connect the white wire from lug 3 of socket V5 to lug B of strip ST22.
- Step 25-B** Connect the purple wire from lug A of strip ST23 to lug J of strip ST13.
- Step 25-C** Cut one lead of one of the 100 mfm disc capacitors, as C23, to 1-inch. Connect this lead to lug B of ST13.
- Step 25-D** Insert the other lead through lug 6 of socket V5 and over to lug 2. Bend the lead over at lug 2 and cut off any excess wire. Solder lug 6 — this lead is the only connection here.
- Step 25-E** Cut one lead of the remaining 100 mfm disc capacitor, as C24, to 1-inch. Connect this lead to G of ST13.
- Step 25-F** Insert the other lead through lug 6 of socket V6 and over to lug 2. Bend the lead over at lug 2 and cut off any excess wire. Solder lug 6 — this lead is the only connection here.
- Step 25-G** Position these capacitors, C23 and C24, as shown, standing on edge.
- Step 25-H** Cut a 1½-inch bare wire and a ¾-inch length of spaghetti. Slip the spaghetti over the wire and connect it from lug D of strip ST13 to lug A of ST22.
- Step 25-J** Cut both leads of one of the 1.2K ohm resistors, (brown, red, red) R43, to ½-inch. Connect R43 from lug 8 of V5 to lug A of strip ST22. Solder (S-one) lug 8 of socket V5.
- Step 25-K** Cut both leads of one of the 680 mfm disc capacitors to ½-inch. Connect it, as C29, between lugs C and D of strip ST13.
- Step 25-L** Cut both leads of the remaining 1.2K ohm resistor to ⅝-inch. Connect it, as R44, from lug 8 of socket V6 to lug J of strip ST13. Solder (S-one) lug 8 of V6.
- Step 25-M** Cut both leads of the remaining 680 mfm disc capacitor to ½-inch. Connect it, as C30, between lugs H and J of strip ST13.
- Step 25-N** Cut both leads of one of the .047 mfm mylar capacitors, as C25, to ¾-inch. Cut two ½-inch lengths of spaghetti. Slip the spaghetti over the leads of C25 and bend the leads as shown. Connect C25 from lug 1 of socket V5 to lug D of strip ST14. Solder (S-two) lug D of ST14.
- Step 25-P** Cut both leads of the remaining .047 mfm mylar capacitor, as C28, to ⅞-inch. Cut two ½-inch lengths of spaghetti. Slip the spaghetti over the leads and bend them as shown. Connect C28 from lug 3 of socket V6 to lug E of strip ST14. Solder (S-two) lug E of ST14.
- Step 25-Q** Cut both leads of the 68K ohm resistor (blue, grey, orange) R50, to ½-inch. Connect R50 between lugs A and B of strip ST23. Solder (S-two) lug A of strip ST23.
- Step 25-R** Cut both leads of the remaining 68K ohm resistor, R49 (blue, grey, orange) to ½-inch. Connect R49 between lugs A and B of strip ST22. Solder (S-three) lug A of strip ST22.
- Step 25-S** Cut 1½-inch of bare wire and a ⅜-inch length of spaghetti. Insert the wire through the spaghetti and connect it between lug 3 of V6 and lug B of ST23. Solder (S-two) lug 3 of V6.
- Step 25-T** Locate the white-green shielded cable from lug B of switch S7. Connect the center wire to lug C of strip ST13; connect the ground wire to lug B of strip ST13.

Figure 26-1

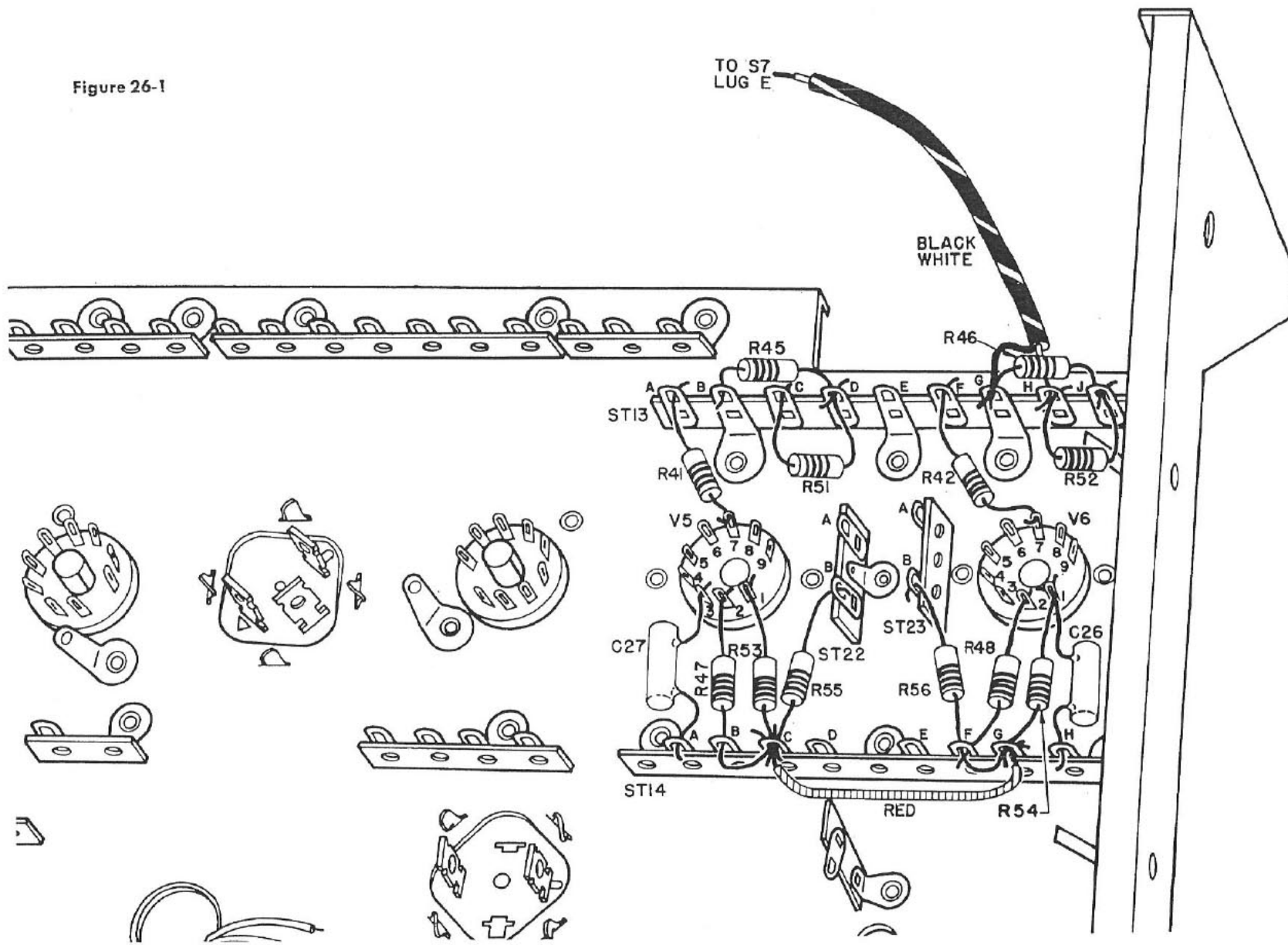

STAGE 26

YOU WILL complete the wiring of the driver, phase-inverter stages V5 and V6.

Step 26-A Locate the black-white shielded cable from lug E of switch S7. Connect the center wire to lug H of strip ST13; connect the ground wire to lug G of strip ST13.

Step 26-B Cut both leads of one of the 1.8K ohm resistors (brown, grey, red), R51, to $\frac{1}{2}$ -inch. Connect R51 between lugs C and D of strip ST13 (in parallel with C29). Solder (S-four) lug C.

Step 26-C Cut both leads of the remaining 1.8K ohm resistor, R52, (brown, grey, red) to $\frac{1}{2}$ -inch. Connect R52 between lugs H and J of strip ST13 (in parallel with C30). Solder (S-four) lug H of strip ST13.

Step 26-D Cut both leads of one of the 220 ohm resistors, R45, (red, red, brown) to $\frac{5}{8}$ -inch. Connect R45 between lugs B and D of ST13. Solder (S-four) lug B; (S-four) lug D.

Step 26-E Cut both leads of the remaining 220 ohm resistor, R46, (red, red, brown) to $\frac{5}{8}$ -inch. Connect R46 between lugs G and J of strip ST13. Solder (S-four) lug G. Solder (S-five) lug J of strip ST13.

Step 26-F Cut both leads of one of the 10K ohm resistors, R41, (brown, black, orange) to $\frac{1}{2}$ -inch. Connect R41 from lug 7 of socket V5 to lug A of strip ST13. Solder (S-one) lug 7 of V5. Solder (S-two) lug A of strip ST13.

Step 26-G Cut both leads of the remaining 10K ohm resistor, R42, (brown, black, orange) to $\frac{1}{2}$ -inch. Connect R42 from lug 7 of socket V6 to lug F of strip ST13. Solder (S-one) lug 7 of V6. Solder (S-two) lug F of strip ST13.

Step 26-H Connect the red wire from lug C of strip ST14 to lug G of strip ST14.

Step 26-J Cut both leads of one of the .047 mfd mylar capacitors to $\frac{1}{2}$ -inch. Connect it, as C26, from lug 1 of socket V6 to lug H of strip ST14. Solder (S-two) lug H of ST14.

Step 26-K Cut both leads of one of the 470K ohm resistors R48, (yellow, violet, yellow), to $\frac{1}{2}$ -inch. Connect R48 from lug 2 of V6 to lug F of ST14. Solder (S-two) lug 2 of V6.

Step 26-L Cut both leads of one of the 56K ohm resistors, (green, blue, orange) R54, to $\frac{1}{2}$ -inch. Connect R54 from lug 1 of socket V6 to lug G of strip ST14. Solder (S-two) lug 1 of socket V6.

Step 26-M Cut ONE lead of one of the 330K ohm resistors R56 (orange, orange, yellow) to $\frac{1}{2}$ -inch; cut the other lead to 1-inch. As shown, connect the shorter lead to lug B of strip ST23. Insert the longer lead through lug F of ST14 and over to lug G of ST14.

Step 26-N Solder (S-three) lug B of strip ST23
 Solder (S-two) lug F of strip ST14
 Solder (S-three) lug G of strip ST14

Step 26-P Cut both leads of the remaining 330K ohm resistor R55 (orange, orange, yellow) to $\frac{1}{2}$ -inch. Connect R55 from lug B of strip ST22 to lug C of strip ST14. Solder (S-three) lug B of ST22.

Step 26-Q Cut both leads of the remaining 56K ohm resistor R53 (green, blue, orange) to $\frac{1}{2}$ -inch. Connect R53 from lug 1 of V5 to lug C of ST14. Solder (S-two) lug 1 of V5.

Step 26-R Cut ONE lead of the remaining 470K ohm resistor R47 (yellow, violet, yellow) to $\frac{3}{8}$ -inch. Cut the other lead to 1-inch. Solder (S-two) the short lead to lug 2 of socket V5. Insert the longer lead through B of ST14 and over to lug C. Solder (S-two) lug B of ST14. Solder (S-four) lug C of strip ST14.

Step 26-S Cut both leads of the remaining .047 mfd mylar capacitor to $\frac{3}{8}$ -inch. Connect it, as C27, from lug 3 of socket V5 to lug A of strip ST14. Solder (S-two) lug 3 of V5. Solder (S-two) lug A of strip ST14.

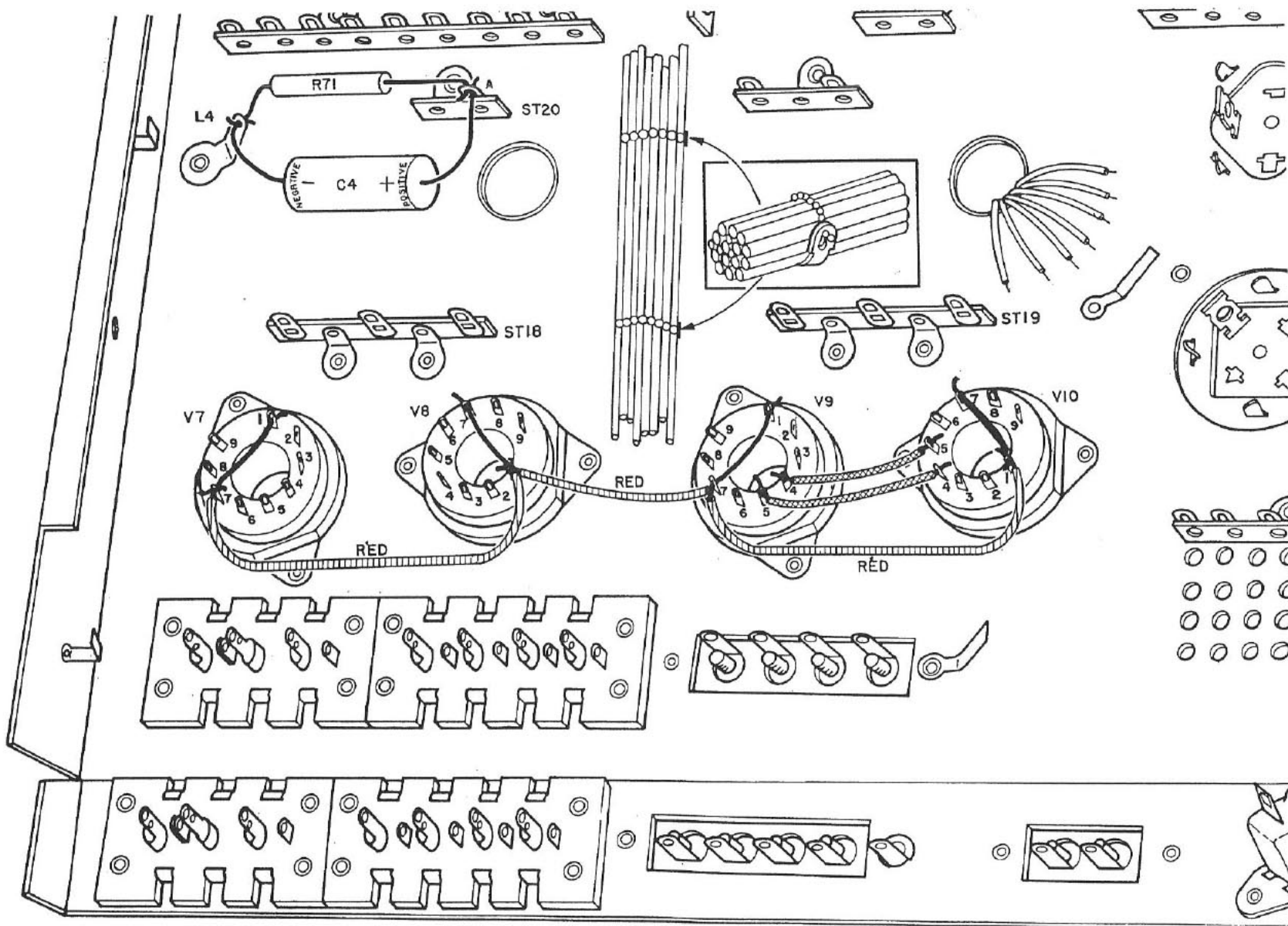

Figure 27-1

STAGE 27

THIS IS THE LAST STAGE of wiring your StrataKit. But don't rush — you still have some mechanical operations.

- Step 27-A** Locate the 560 ohm, 5 watt resistor, R71, and cut both leads to $\frac{5}{8}$ -inch. Connect R71 between L4, and lug A of strip ST20.
- Step 27-B** Cut both leads of the 100 mfd electrolytic capacitor, C4, to 1-inch. Cut a $\frac{5}{8}$ -inch length of spaghetti. Note that C4 is polarized — one side is positive (or +) and the other is negative (or -). Solder (S-three) the *negative* side to lug L4. Slip the spaghetti over the *positive* lead and solder (S-three) it to lug A of strip ST20.
- Step 27-C** Locate one of the (longer) 4-inch red wires. At one end, remove enough insulation to give you $1\frac{1}{8}$ -inch bare wire. Insert this end through lug 7 of socket V7 and over to lug 1—cut off any excess wire. Solder both lugs—this is the only connection here.
- Step 27-D** Connect the other end of the wire to lug 1 of socket V8.
- Step 27-E** Locate the (shorter) 3-inch red wire and remove enough insulation from one end to give you $1\frac{1}{8}$ -inch of bare wire. Insert the wire through lug 1 of V8 and over to lug 7—cut off any excess wire. Solder both lugs—these are the only connections here, too.
- Step 27-F** Connect the other end of the wire to lug 7 of socket V9.
- Step 27-G** Locate the remaining red wire and again remove enough insulation to give you $1\frac{1}{8}$ -inch of bare wire. Insert this end through lug 7 of socket V9 and over to lug 1—cut off

any excess wire. Solder lugs 1 and 7 of V9 (only connections here).

- Step 27-H** Connect the other end to lug 1 of socket V10 and solder the lug. At this lug there should be a bare wire over to lug 7 and a red wire over to lug A of strip ST17.
- Step 27-J** Cut a $1\frac{1}{2}$ -inch length of bare wire and a $\frac{7}{8}$ -inch length of spaghetti.
- Step 27-K** Solder (S-two) one end of the wire to lug 5 of socket V10. Slip the spaghetti over the wire and solder (S-two) the other end to lug 4 of socket V9.
- Step 27-L** Cut a $1\frac{3}{4}$ -inch length of bare wire and a $1\frac{1}{4}$ -inch length of spaghetti.
- Step 27-M** Solder (S-two) one end of the wire to lug 4 of socket V10. Slip the spaghetti over the wire and solder (S-two) the other end to lug 5 of socket V9.
- Locate the two cable clamps from StrataPack 27 and examine them and the insert in Fig. 27-1. Notice the clamp is placed under the entire group of wires. The "bead" end is then inserted through the hole in the "tab" and, pulled tight and cut off, leaving two beads.
- Step 27-N** Install one cable clamp near strip ST20.
- Step 27-P** Install the other cable clamp near strips ST18 and ST19.

STAGE 28

THIS IS THE FINAL STAGE of your StrataKit assembly. You will complete the mechanical assembly, plug in the tubes, etc.

No doubt you are in a hurry to complete your StrataKit and try it out! However, before applying power to your Fisher KX-100 it is strongly suggested that you examine it visually to be certain there are no shorts or unsoldered connections. This can be easily and quickly done with the help of Figures 8 and 9.

Carefully examine each lug, on the front panel and in the chassis, and as you do so, check it off on Figure 8 and 9. (A red pencil would help here.) When you are finished, every lug (terminal strip, tube socket, and switch) will be covered. As you examine each lug make certain it is properly soldered, particularly if there are more than three wires connected. If you are doubtful, touch your hot soldering iron to the lug to melt the solder.

Also look for shorts caused by bare wires touching each other, touching lugs or the chassis. Be sure the tube socket lugs are not shorted against each other.

Carefully compare the positioning of the wires and components against the illustrations in each stage and the photos in Figures 10 and 11. If you are certain that "all is well" proceed as follows:

The Lamp Shield

Remove the length of (large) sleeving from StrataPack 28 and examine it. Notice that one end is cut straight and the other diagonally. The sleeving is intended to slip over the pilot lamp with the diagonally cut end flush against the dress panel. Place the sleeving over the lamp.

Mounting the Dress Panel

Remove the dress panel from the box and unwrap it carefully. The dress panel is held on the front panel by two hex nuts — one on the "Mode Selector" (S2) switch and the other on the "Balance" (PO4) control. Locate the two large hex nuts from StrataPack 28. Turn the chassis to its normal upright position with the control shafts facing

you. Now place the dress panel on the front of the chassis as shown in Fig. 28-1. Although you should have no difficulty getting the control and switch shafts to project through their proper holes in the dress panel, the slide switches may need adjustment. This is done by loosening the screws holding the slide switches and moving the switches until the knob is in the center of the rectangular hole of the dress panel. Of course, you'll need to slip the dress panel on and off several times until all five slide switches are properly adjusted.

When you are certain all the slide switches are properly centered: Permanently mount the dress panel. When you tighten the two hex nuts be sure you do not mar the panel.

Knobs

Turn over the chassis with the front panel facing you and locate the knobs. Refer to Figure 28-1 and place the knobs on the shafts. You'll find the knobs can only fit on one way — except for the dual tone-control type. It is possible to place the inner section on upside down. After these dual knobs are on, rotate them counterclockwise. The indicating "dot" on the brass ring portion of the knob should be pointing to "Min" (minimum). If not, remove the knobs and reverse them.

And Now The Tubes

Remove all of the tubes from the box. Plug the 12AX7/ECC83 tubes in the 9 pin sockets V1 through V6. Note that there is a space between pins 1 and 9 on both the tube and the socket so that it can only be plugged in one way. Locate the four tube shields and place them over tubes V1, V2, V3 and V4.

Remove the four 7868 novar power output tubes and plug them into the (larger) novar type 9-pin sockets at the rear of the chassis. Notice that these tubes and sockets are also keyed by spaces between pins 1 and 9.

Remove the fusepost cap by rotating it counter-clockwise. Insert one of the fuses from StrataPack 28 in the post and replace the cap — note that it is spring-loaded. (The other fuse is an extra.)

The Front Panel Shield (and plug-in button)

Locate the front panel shield and remove the six (No. 6) self-tapping

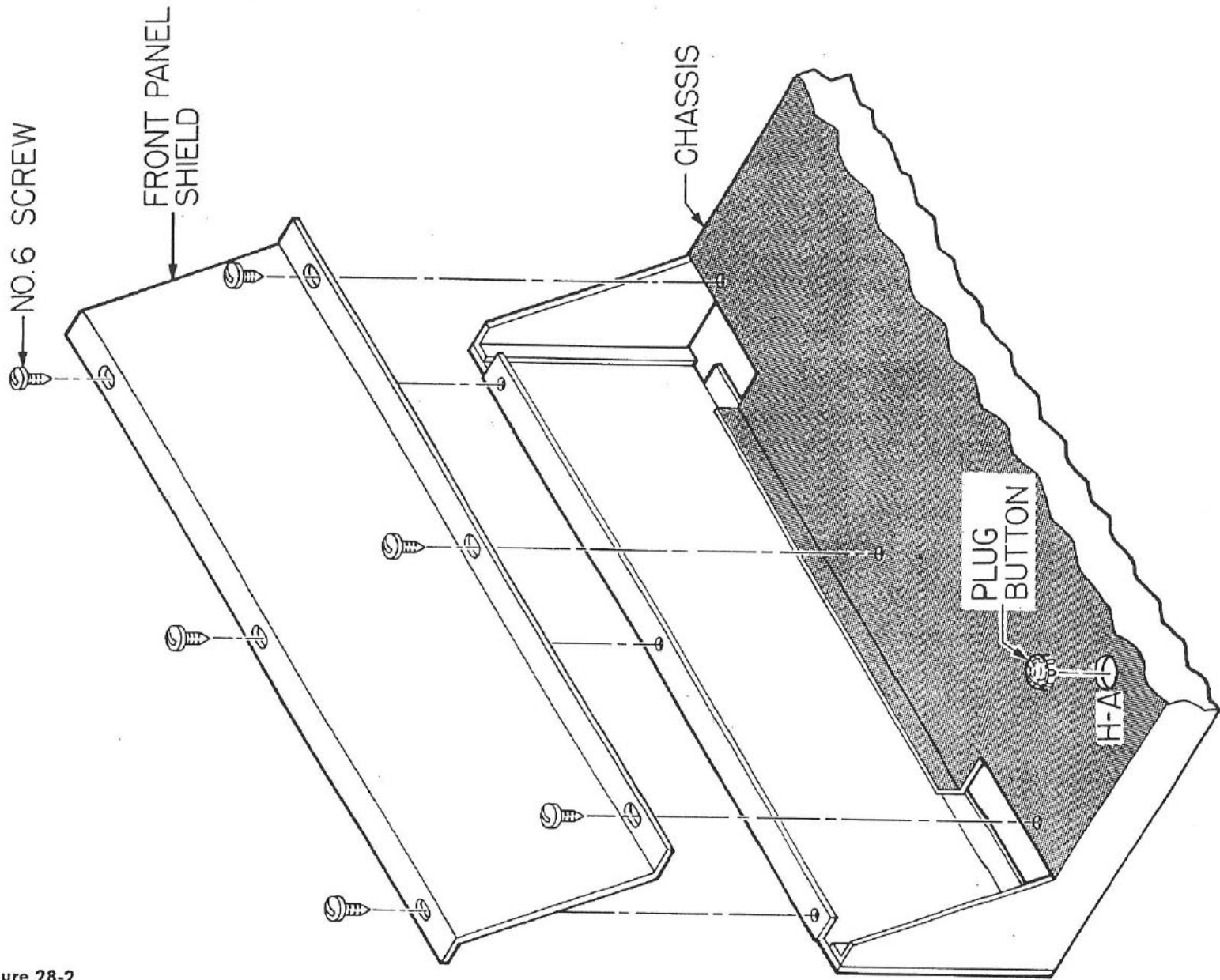

Figure 28-2

screws from the StrataPack. Refer to Fig. 28-2 and mount the shield as shown. Insert the plug-button in chassis hole H-A as shown.

Adjusting The KX-100

Turn all of the front panel controls as follows:

- | | |
|---|----------|
| <input type="checkbox"/> Input Selector | : Tuner |
| <input type="checkbox"/> Mode Selector | : Stereo |
| <input type="checkbox"/> Bass (Both) | : Normal |
| <input type="checkbox"/> Treble (Both) | : Normal |
| <input type="checkbox"/> Balance | : Normal |
| <input type="checkbox"/> Master Volume | : AC OFF |
| <input type="checkbox"/> Equalization | : Phono |
| <input type="checkbox"/> High Filter | : OFF |
| <input type="checkbox"/> Tape Monitor | : OFF |
| <input type="checkbox"/> Loudness Contour | : OFF |
| <input type="checkbox"/> Speaker Switch | : ON |

The above adjustments are, of course, initial and you will probably change them after you install the KX-100 in your system.

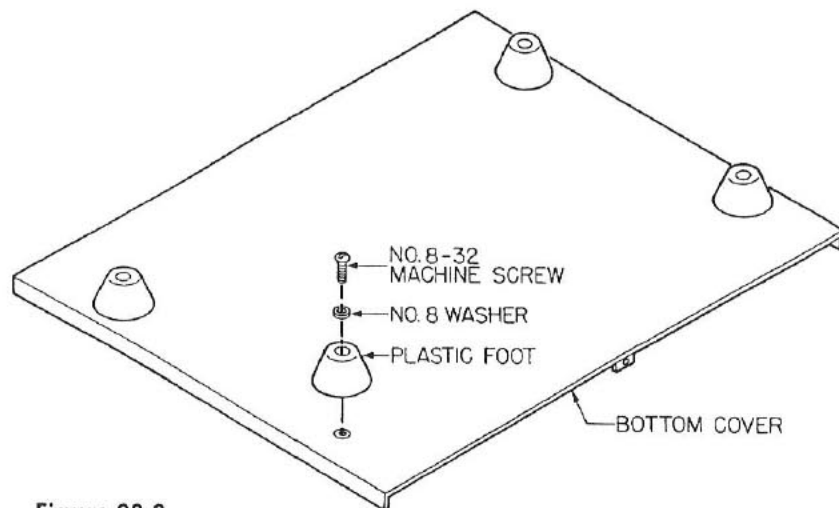

Figure 28-3

The Bottom Cover

Locate the five remaining No. 6 self-tapping screws. Note in Fig. 28-3 that three edges of the bottom cover are bent over while the fourth has only a tab in the center. The edge with the tab should be at the rear of the chassis. Place the bottom cover over the chassis with all edges on the outside of the chassis. The tab at the rear fits inside. Secure the cover in place with the No. 6 self-tapping screws. "Start" all of the screws before tightening any of them.

Installation

Full information on installing your FISHER KX-100 StrataKit is included in the Operating Manual. The four plastic feet are installed on the bottom cover as shown in Figure 28-3.

Maintenance

- Your FISHER StrataKit has been designed for long, trouble-free life and should require little service except normal tube replacement.

In Case Of Difficulty . . .

No matter what trouble you may encounter, we will be glad to help you in any way we can.

Should any part fail, it would be best to write us before returning it, giving a full description of the trouble. The damage may have been caused by another defective part of which you are unaware and, if so, the replacement part may also become damaged.

Before returning a sub-assembly, written permission must be obtained.

Experience has shown that most of the difficulties encountered in Kits are due to improperly soldered connections or incorrect wiring. Therefore, if your unit does not work properly, first check the wiring against the illustrations and, if you are technically minded, the schematic. Note that the schematic diagram lists the operating voltages. If you are still unable to locate the trouble, write us immediately and describe the difficulty fully, as well as the steps you have already taken to try to locate and correct it.

Address your inquiry to:

Fisher Radio Corporation
StrataKit Division
21-21 44th Drive, Long Island City 1, N. Y.

If on the remote chance the difficulty cannot be cleared up by mail you can return your KX-100 to us for adjustment to top operating condition.

If the trouble is due to an in-warranty part or sub-assembly, there will be no charge. If the trouble is due to an assembly error or if further work is required or requested (alignment, etc.) there will be a uniform charge of \$10.00 plus the cost of any parts damaged through construction errors.

Remember that this service is intended for repairs and not wiring. The kit must be completely wired substantially in accordance with the instructions in this manual.

If it does become necessary to return the unit, ship by prepaid Railway Express. Return shipment will be made by express collect. Be sure to pack the unit carefully — note that the carrier cannot be held liable for damage in transit if the packing, in his opinion, is insufficient. Therefore, pack the unit carefully in a rugged container completely surrounded by packing material (shredded newspaper or excelsior). Attach a tag to the unit giving your name and address and a description of the difficulty.

IMPORTANT

Please do not return the unit without first writing us for proper authorization.



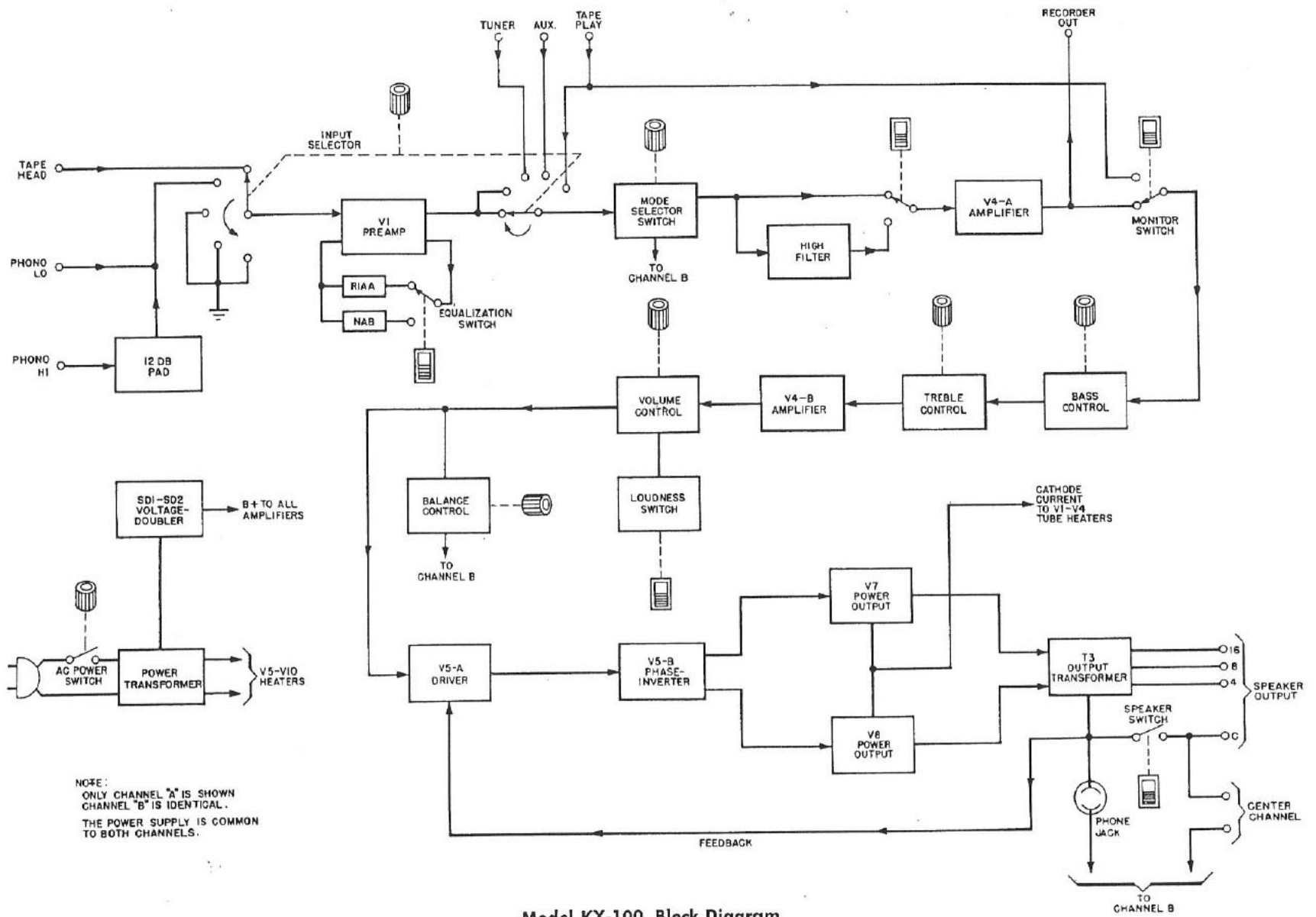

How Your FISHER KX-100 Operates

Since the A and B channels of the KX-100 are electrically identical, only channel A is described below.

Inputs and Preamp stages

The KX-100 has a total of six inputs (for each channel) of which three are fed to the input of the preamplifier stage, V1. The remaining inputs join later on — they are used for program sources which do not need the extra amplification and equalization offered by the preamp. The preamplifier (if its name hasn't already betrayed it) amplifies *low-level* signals, such as those from a phonograph pickup cartridge or a magnetic tape playback head about one hundred times, to the point where they have sufficient strength to drive the main amplifier.

But that's only half the story. For valid technical reasons, disc and tape recordings are made with high frequencies boosted in a carefully prescribed way. It is the preamplifier's second job to restore the balance, or *equalize* the program source by boosting the low frequencies and dropping off the highs, in a way exactly opposite to that followed during recording. The result is a "flat" response curve, uniform from the lowest to the highest audible frequencies.

The preamplifier stages in the KX-100 have a choice of equalization curves: RIAA (Recording Industry Association of America) for phonograph records, and NAB (National Association of Broadcasters) for tapes. One of the two is selected by the Equalization switch on the front panel.

At this point the audio signals from the PHONO or TAPE inputs have about the same voltage level and frequency characteristics as the other input sources. A section of the Input Selector can now be set to choose one program source (either from the output of the preamp or from one of high level input jacks) and feed it to the rest of the amplifier.

High Filter and Tone Control Stages

The source selected by the Input Selector is passed on to V4A, which amplifies it still further. Just before this point, the Mode Selector offers a choice of three different modes of operation. In MONO, the input of V4A and its corresponding stage in channel B are connected together, making the two separate amplifiers in the KX-100 work together as one to produce a monophonic signal from a stereo source. This feature also allows you to connect a monophonic source to *only* the channel A or channel B inputs, and have it appear at both outputs. In STEREO, the left and right signals are fed to the left (A) and right (B) channels of the KX-100 in normal fashion. In REVERSE, the input signals are "crossed," so that the left signal feeds the right channel, and the right signal, the left channel. This corrects for switched channels on a recording or broadcast.

The High Filter, which can be cut in or out of the circuit with a switch on the front panel, is a resistance-capacitance network that offers progressively more attenuation as the audio signal frequency gets higher. By using a circuit with a steep attenuation characteristic (which is what we've done here, with the help of a little feedback), it becomes practical to reduce very substantially the annoying snap, crackle and pop associated with worn records or weak radio signals without seriously affecting the higher musical tones. This is quite in contrast to brute-force "scratch filters," which remove most of the music's brilliance along with the noise.

The output of V4A is routed to two points: the recorder output jack, and the remainder of the amplifier. The Tape Monitor switch appears at this point. In its OFF position, signals will travel from the output of V4A to the rest of the amplifier, emerging eventually from the speakers. When the Tape Monitor switch is slid to ON, the amplifier from that point on is connected directly to the TAPE PLAY jack, allowing you to listen to the *playback* signal from the tape you are recording (provided, of course, that you have a tape recorder with separate record and playback heads). In the ON position of the Monitor switch, signals from the earlier stages of the amplifier are cut off at this point, but they are still fed to the recorder output jacks.

Next in line are the Bass and Treble controls, which, like the High

Filter, are resistance-capacitance networks, but designed with variable elements so that low and high audio frequencies can be controlled over a range of some 20 db of boost or attenuation.

A tone control circuit of this type has considerable loss over the entire audio range when the controls are set to their mid-positions. V4B supplies gain to make up for the loss. Subsequently, the volume control taps off a part of the signal voltage (anywhere from zero to the full amount present after V4B), and the audio reaches the grid of the driver stage.

We should pause for a moment to consider the Balance control. This is a vital element in any stereo system, since its ultimate function is to make the amplification of the left and right channels equal. Theoretically, this should occur when the balance control is set at the exact center, but this assumes that you are using two perfectly identical speakers in perfectly identical enclosures in perfectly balanced positions in a perfectly symmetrical room. Not too likely, what? Not at all, in fact. That is why you have built a balance control into your KX-100. All it does, really, is to reduce the gain of one channel below that of the other and thereby compensate for discrepancies in the system or in the program source (let's not overlook *that* as a source of trouble!)

The Power Amplifier Section

The first stage (V5A) in this part of the amplifier bears the burden of voltage amplification: the next stage (V5B) provides no gain at all, really, but it has the most interesting and exacting task of all those in the amplifier. It must split the incoming signal into two exactly equal halves, 180° (a half-cycle) out of phase with each other, as required for "push-pull" operation. This second part happens more or less automatically; it's the first part that's hard since the two parts must be equal over the entire audio range. There are many variations of these *phase inverter* circuits (some call them "phase splitters"), but the one we have chosen is simple, has extremely low distortion, and — nicest of all — its precision is not affected by tube aging, voltage variations, or any other incidental phenomena.

The two equal, out-of-phase signals are fed to the two push-pull novar type 7868 output tubes V7 and V8. These tubes work together to provide the audio power which actually drives the speaker. The output

transformer (T3) recombines the two "half-signals" into one whole, and changes the high-voltage, low-current audio at the tubes into low-voltage, high current audio needed for the speakers.

One more thing (and very important, since it is largely responsible for the superb performance of the KX-100), and that is *feedback*. Without negative feedback, we have just an amplifier. With negative feedback, the amplifier becomes a tightly controlled device which, in a large part, corrects for its own errors! What actually happens is this: a portion of the output signal, from across the secondary winding of the output transformer, is sampled and fed back to an earlier point (in this case, the cathode of the driver stage). It is fed back in such a way that it cancels most of the irregularities that happen to appear in the output signal. This includes distortion, peaks or dips in frequency response, hum and, to some degree, random noise. If, for example, at some particular range of frequencies the gain of the amplifier increases, the output voltage increases also. This means that the amount of feedback increases. But since the feedback is negative, or *de-generative*, it counteracts the rise in gain, bringing things back down to normal once more. Clever? Actually every stage in the KX-100 has at least one feedback loop, but this is the one which plays the biggest role in reducing distortion to such a low level.

The Power Supply

The power transformer, T1, changes the 117-volt AC household power to the two supply-voltage levels required by the tubes: 6.3 volts for the heaters (filaments) of V5 through V10, and, ultimately, 400 volts for the plates of the tubes. (The 190 volts AC at the high-voltage winding of the transformer will go up to about 400 volts DC by the time we're through with it.) Two silicon diodes are connected in a full-wave voltage-doubler configuration. They change the high-voltage AC into DC which reaches a level approximately equal to *twice* the peak voltage of the AC.

The 7868 output tubes draw by far the largest share of power from the DC power supply. Part of the current that flows through them is shunted through the heaters of V1, V2, V3 and V4. It is, of course, purest DC, since it has been carefully smoothed and filtered. Thus, the low-level amplifying stages have DC-operated heaters, and — no hum!

PARTS LIST

Capacitors

10% tolerance for all fixed capacitors, unless otherwise noted or marked GMV (guaranteed min. value). All capacitors not marked are pF (uuf).

Symbol	Description	Part No.
C1	Electrolytic, 200uf, 250V	C50180-20
C2	Electrolytic, 2 section: A: 200uf, 250V B: 40uf, 500V	C50180-19
C3	Electrolytic, 3 section: A: 40uf, 450V B: 40uf, 400V C: 20uf, 300V	C50180-18
C4	Electrolytic, 100uf, 100V	C633-143
C5, 6	Ceramic, .01uf, 20%, 500V	C50089-3
C7, 8	Mylar, .022uf, 400V	C50197-28
C9, 10	Ceramic, 68, 1000V	C50070-16
C11, 12	Ceramic, 680, 1000V	C50072-2
C13, 14	Mylar, .022uf, 400V	C50197-28
C15, 16	Ceramic, 180, 1000V	C50072-23
C17, 18	Mylar, .047uf, 400V	C50197-30
C19, 20	Ceramic, 68, 1000V	C50070-16
C21, 22	Mylar, .022uf, 250V	C50197-49
C23, 24	Ceramic, 100, 5% 1000V	C50070-19
C25, 26, 27, 28	Mylar, .047uf, 400V	C50197-30
C29, 30	Ceramic, 680, 1000V	C50072-2
C31, 32	Ceramic, 10, 1000V	C50070-11

Resistors and Potentiometers

In Ohms, 5% tolerance, 1/3 Watt, unless otherwise noted
K=Kilohms, M=Megohms

Symbol	Description	Part No.
R1, 2	Dep. Carbon, 220K	R33DC224J
R3, 4	Dep. Carbon, 56K	R33DC563J
R5, 6	Dep. Carbon, 100K	R33DC104J

R7, 8	Dep. Carbon, 56K	R33DC563J
R9, 10	Dep. Carbon, 10K	R33DC103J
R11, 12	Glass, 330K, 1W	R30G334J
R13, 14	Glass, 2.2K, 1W	R30G222J
R15, 16	Dep. Carbon, 2.2M	R33DC225J
R17, 18	Dep. Carbon, 220K	R33DC224J
R19, 20	Dep. Carbon, 560K	R33DC564J
R21, 22	Composition, 10M, 10%, 1/2W	RC20BF106K
R23, 24	Dep. Carbon, 2.2M	R33DC225J
R25, 26	Dep. Carbon, 2.2K	R33DC222J
R27, 28	Dep. Carbon, 82K	R33DC823J
R29, 30	Dep. Carbon, 1M	R33DC105J
R31, 32, 33, 34	Dep. Carbon, 220K	R33DC224J
R35, 36	Dep. Carbon, 2.2K	R33DC222J
R37, 38	Dep. Carbon, 82K	R33DC823J
R39, 40	Dep. Carbon, 22K	R33DC223J
R41, 42	Dep. Carbon, 10K	R33DC103J
R43, 44	Dep. Carbon, 1.2K	R33DC122J
R45, 46	Dep. Carbon, 220	R33DC221J
R47, 48	Dep. Carbon, 470K	R33DC474J
R49, 50	Dep. Carbon, 68K	R33DC683J
R51, 52	Dep. Carbon, 1.8K	R33DC182J
R53, 54	Dep. Carbon, 56K	R33DC563J
R55, 56, 57, 58, 59, 60	Dep. Carbon, 330K	R33DC334J
R61, 62, 63, 64	Dep. Carbon, 1K	R33DC102J
R65, 66	Glass, 25, 10%, 5W	RPG5W250K
R67, 68	Composition, 330, 10%, 1W	RC30BF331K
R69	Composition, 3.3K, 1/2W	RC20BF332J
R70	Composition, 6.8K, 1/2W	RC20BF682J
R71	Glass, 560, 10%, 5W	RPG5W561K
R72	Glass, 2.5K, 10%, 10W	RPG10W252K
R73	Composition, 1K, 10%, 1/2W	RC20BF102K
R74	Composition, 2.2K, 10%, 1/2W	RC20BF222K
R75	Composition, 100K, 10%, 1/2W	RC20BF104K
PO1	Potentiometer, 500K, Dual Bass	R50160-127
PO2	Potentiometer, 500K, Dual Treble	R50, 160-127
PO3	Potentiometer, 500K, Dual Volume	R50160-128
PO4	Potentiometer, 500K, Balance	R50160-129

Miscellaneous

Symbol	Description	Part No.
CP1, 2	Printed Circuit, Phono-Tape Equalization	PC50187-3
CP3, 4	Printed Circuit, High Filter	PC50187-2
CP5, 6	Printed Circuit, Tone Control	PC50187-9
F1	Fuse, 3.2 Amp., Slo-Blo	F3319
I1	Pilot Lamp #470F	I50009-4
J1, 3	Jack, 4-Contact	J50190-1
J2, 4	Jack, Triple	J50081-3
J5	Jack, earphones	J846-120-1
S1	Switch, selector	S995-117
S2	Switch, mode selector	S995-114
S3, 4, 5, 6, 7	Switch, Slide	S50200-5
SD1, 2	Silicon Diode	SR50411-1
T1	Transformer, power	T951-115
T2	Transformer, output, CH B	T849-116-6
T3	Transformer, output, CH A	T849-116-5
—	Dress Panel	AS994-108
—	Pilot Lamp Socket	AS781-118
—	Plug Button	A50418
—	Control Panel Shield	A781-112
—	Bottom Cover	A995-118
—	Spool of solder	A909-119
—	Switch Shield	A50273
—	Tube Shield	E3287
—	Knob	E50324
—	Knob, dual front	E50323
—	Knob, dual rear	E50221
—	Strain Relief	E50008-2
—	Plastic Foot	H50277
—	Brass Hex Nut $\frac{3}{8}$ -32	H505-127
—	Jewel, green	I50162-4
—	Construction Manual	N994-103
—	Operating Instructions	N994-104
—	Line Cord	W50023-1
—	Fuse Holder	X563-151
—	Tube Socket — 9 Pin V1-V4	X50321-15
—	Tube Socket — 9 Pin V5-V6	X50321-8
—	Tube Socket, Novar	X50321-20