



Crown

DC-300A
IM-9
S2P2-18-1

INSTRUCTION MANUAL

SERIAL NO _____
ISSUED _____

DC-300A
DUAL CHANNEL
LABORATORY AMPLIFIER

TABLE OF CONTENTS

	PAGE
Section 1 DESCRIPTION	1
1.1 General	1
1.2 Specifications	2, 2A, 2B, 3, 4, 5, 6, 7, 8, 9, 10
1.3 Warranty	10
Section 2 INSTALLATION	
2.1 Unpacking	11
2.2 Mounting	11
2.3 Normal Hi-Fi Installation	11
2.4 Connecting Output Lines	12
2.5 Connecting Input Lines	14
2.6 Connecting Power	15
Section 3 OPERATING INSTRUCTIONS	
3.1 Controls and Adjustments	17
3.2 The Protection Mechanisms	17
3.3 Operating Precautions	19
3.4 Load Protection Methods	19
3.5 Cleaning	21
Section 4	
4.1 Principles of Operation	23
4.2 Test Procedures	23
4.3 Service	24
Section 5 APPLICATION NOTES	27
SPEAKER PROTECTION NOTE	33

LIST OF ILLUSTRATIONS

TITLE	PAGE
1-1 DC-300A Pictorial	1
1-2 DC-300A Performance Graphs	
I.M. Distortion	3
Harmonic Distortion	3
Frequency Response	4
Power Response	4
Phase Response	5
Noise Spectrum	6
Crosstalk	6
Typical Limits of V.I. Output	7
Damping Factor	8
Power Efficiency	8
Input Impedance vs. Gain	9
Maximum Output Vs. Load Impedance	9
Output $ Z $	10
Output $ \angle $	10

1.1 GENERAL



FIG. 1 - 1
DC-300A PICTORIAL

The DC-300A is a dual-channel high-power amplifier for precision amplification of frequencies from DC to 20KHz. The unit features extremely low harmonic and intermodulation distortion, very low noise, highest "damping factor," and quality parts and workmanship. Because of the large output power, it is possible to obtain a monaural 70-volt balanced line without using an output transformer.

The DC-300A contains a new CROWN developed **Signal Programmed Automatic Current Executor (SPACE control)** electronic amplifier protection circuit which manifests no flyback pulses, thumps, or shut-down. At audio frequencies any impedance load including totally reactive loads may be driven with no adverse effects. Only maximum output power will be affected by variations in load impedance. At sub-sonic to DC frequencies the limiter acts as a \sqrt{I} limiter to provide optimum protection for the extremely rugged silicon homotaxial output devices (total of 16 for a total of 2400W dissipation).

A pair of thermal switches remove power from the unit if overheating occurs due to insufficient ventilation. The AC line is fused to protect the power supply.

See Section 3.2 for a description of the protective systems.

The power supply features a 1KW transformer and large computer-grade filter capacitors giving over 48 joules of energy storage.

A total of 37 discrete transistors, 1 linear IC (dual op

amp), 24 diodes, 1 bridge rectifier, and 3 zener diodes are used in the DC-300A circuitry. With the integrated circuit, the effective number of semiconductors is 53 transistors, 34 diodes, and 3 zener diodes.

The output devices, 8/channel, are conservatively employed, having a total peak current rating/channel of 120 amps in a circuit that is limited to a maximum of 28 amps. Among its unique features, the circuitry includes the CROWN-pioneered and patented AB+B output configuration.

The input operational amplifiers are powered by two voltage-regulated supplies. This results in complete channel-to-channel isolation and independence from line voltage variations.

Total direct coupling results in perfect, instantaneous, thump-free overload recovery even on non-symmetrical waveforms. This cannot be said for any AC-coupled amplifier presently in existence. Turn-on is instantaneous with no thumps or program delays.

Front-panel controls include two independent heavy-duty level controls and a power switch with an associated pilot light. DC balance controls, which never need adjustment in normal operation, are located behind the front-panel.

1.2 SPECIFICATIONS

1.2.1 STEREO SPECIFICATIONS

Output Power 155 watts per channel minimum RMS (both channels operating) into an 8 ohm load over a bandwidth of 1 Hz-20KHz at a rated RMS sum total harmonic distortion of 0.05% of the fundamental output voltage.

Frequency Response	± 0.1 dB DC-20KHz at 1 watt into 8 ohms; ± 1 dB DC-100KHz.
1KHz Power	180 watts RMS into 8 ohms, per channel, both channels operating, 0.1% total harmonic distortion.
Harmonic Distortion	Less than 0.001% from 20Hz-400Hz, and increasing linearly to 0.05% at 20KHz at 150 watts RMS per channel into 8 ohms.
I.M. Distortion (60Hz-7KHz 4:1)	Less than 0.05% from 0.01 watts to 0.25 watts and less than 0.01% from 0.25 watts to 150 watts into 8 ohms, per channel.
Slewing Rate	8 volts per microsecond (slewing rate is the maximum value of the first derivative of the output signal, or the maximum slope of the output signal).
Damping Factor	Greater than 750, DC-400Hz into 8 ohms.
Output Impedance	Less than 7 milliohms in series with less than 3 microhenries.
Load Impedance	Rated for 8 ohm usage; safely drives any load including completely reactive loads.
Voltage Gain	$20.6 \pm 2\%$ or 26.3 ± 0.2 dB at maximum gain.
Input Sensitivity	1.75 volts $\pm 2\%$ for 150 watts into 8 ohms.
Output Signal	Unbalanced, dual channel.

1.2.2 MONAURAL SPECIFICATIONS

Output Power 310 watts minimum RMS into a 16 ohm load over a bandwidth of 1Hz-20KHz at a rated RMS sum total harmonic distortion of 0.05% of the fundamental output voltage.

Frequency Response	± 0.15 dB, DC-20KHz at 1 watt into 16 ohms; ± 1 dB, DC-60KHz at 1 watt into 16 ohms.
1KHz Power	360 watts RMS into 16 ohms.
Harmonic Distortion	Less than 0.001% from 20Hz-400Hz and increasing linearly to 0.05% at 20KHz at 300 watts into 16 ohms.
I.M. Distortion	Less than 0.05% from 0.01 watts to 0.25 watts and less than 0.01% from 0.25 watts to 300 watts into 16 ohms.
Slewing Rate	16 volts per microsecond.
Damping Factor	Greater than 700, DC-400Hz into 16 ohms.
Output Impedance	Less than 15 milliohms in series with less than 6 microhenries.
Load Impedance	Rated for 16 ohm usage; safely drives any load including completely reactive loads.
Voltage Gain	41.2 \pm 2% or 32.3 \pm 0.2dB at maximum gain.
Input Sensitivity	1.75 volts for 300 watts into 16 ohms.
Output Signal	Balanced, single channel.

2.3 GENERAL SPECIFICATIONS

Hum and Noise (20Hz-20KHz)	110dB below rated output.
Phase Response	+0, -15° Zero to 20KHz at 1 watt.
Input Impedance	100K ohms at minimum gain, 10K ohms at maximum gain.
Amplifier Output Protection	Short, mismatch, and open circuit proof. Limiting is instantaneous with no flyback pulses, thumps, cutout, etc. No premature limiting on transients.
Overall Protection	AC line fused. Thermal switch in AC line protects against overheating caused by insufficient ventilation. Controlled slewing rate voltage amplifiers protect overall amplifier against RF burn-outs. Input overload protection is furnished by internal resistance at inputs of amp.
Turn-on	Instantaneous, with minimum thumps and no program delay.
Circuit	Wideband multiple feedback loop design utilizing one linear IC (dual op-amp). Total equivalent of 59 transistors, 32 signal diodes, 3 zeners and 6 rectifier diodes.
Power Supply	1 kilowatt transformer with massive computer-grade filter capacitors storing over 48 joules of energy. Two regulated supplies for complete isolation and stability.
Power Requirements	Requires 50-400Hz AC with selectable taps for 120, 128, 240, 248, and 256V \pm 10% operation. Draws 40 watts or less on idle, 500 watts at 300 watts total output.
Heat Sinking	Massive black-anodized heat sinks are thermally joined with the chassis, thereby utilizing the entire amplifier as a heat sink.
Chassis	All aluminum construction for maximum heat conduction and minimum weight. Heavy aluminum front panel is a single extrusion.
Controls	Independent input level controls are on front panel. Power switch, with integral pilot light is on front panel. Non-interacting DC balance controls are mounted behind front panel.
Connectors	Input — ¼ inch phone jack Output — Color coded binding posts AC Line — Three-wire (grounded) male connector on 5 ft. min. cable.
Dimensions	19 inch standard rack mount (W.E. hole spacing), 7 inches high, 9¾ inches deep (from mounting surface).
Weight	45 pounds
Finish	Bright-anodized brushed aluminum front panel with black leatherette lower panel.

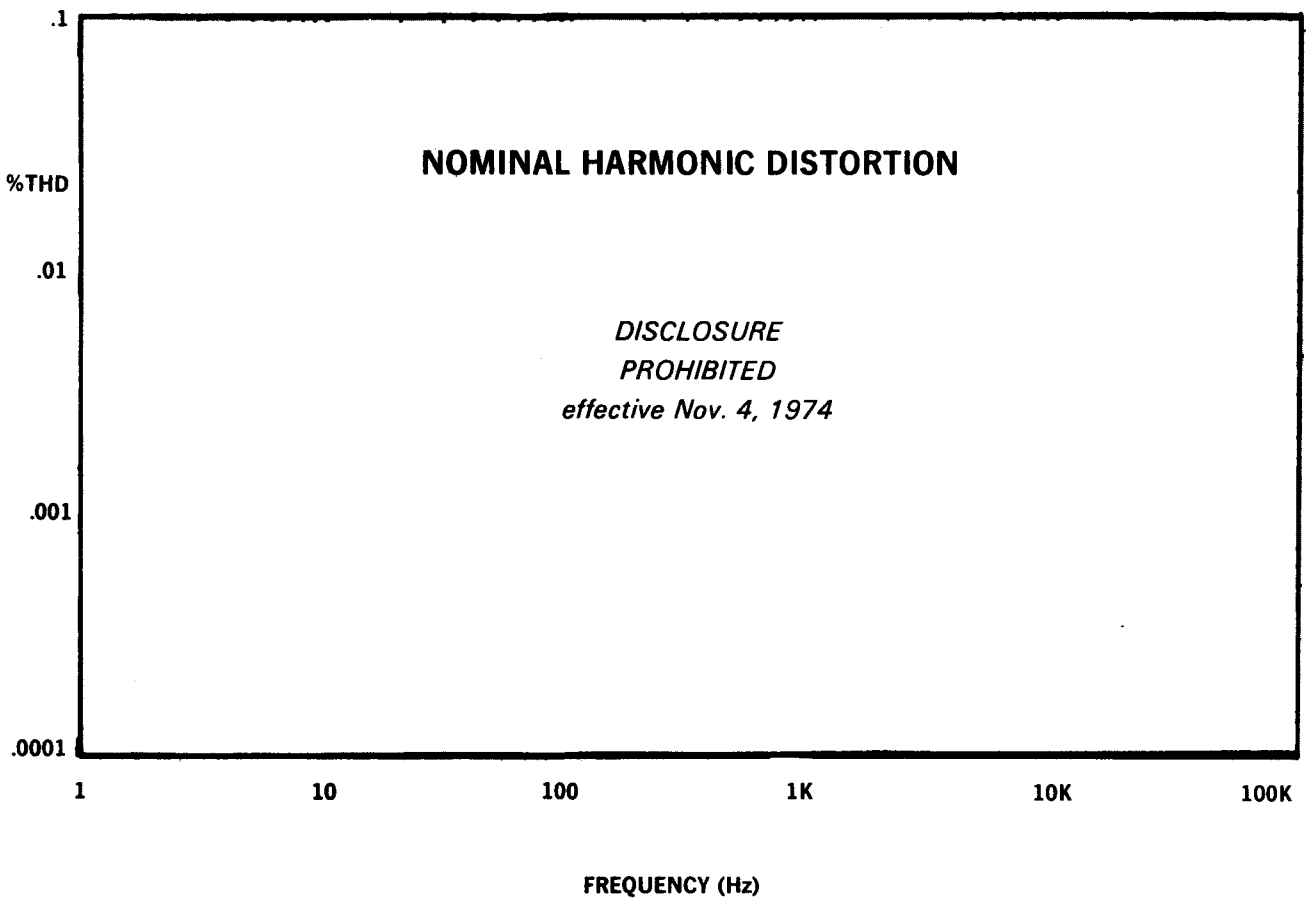
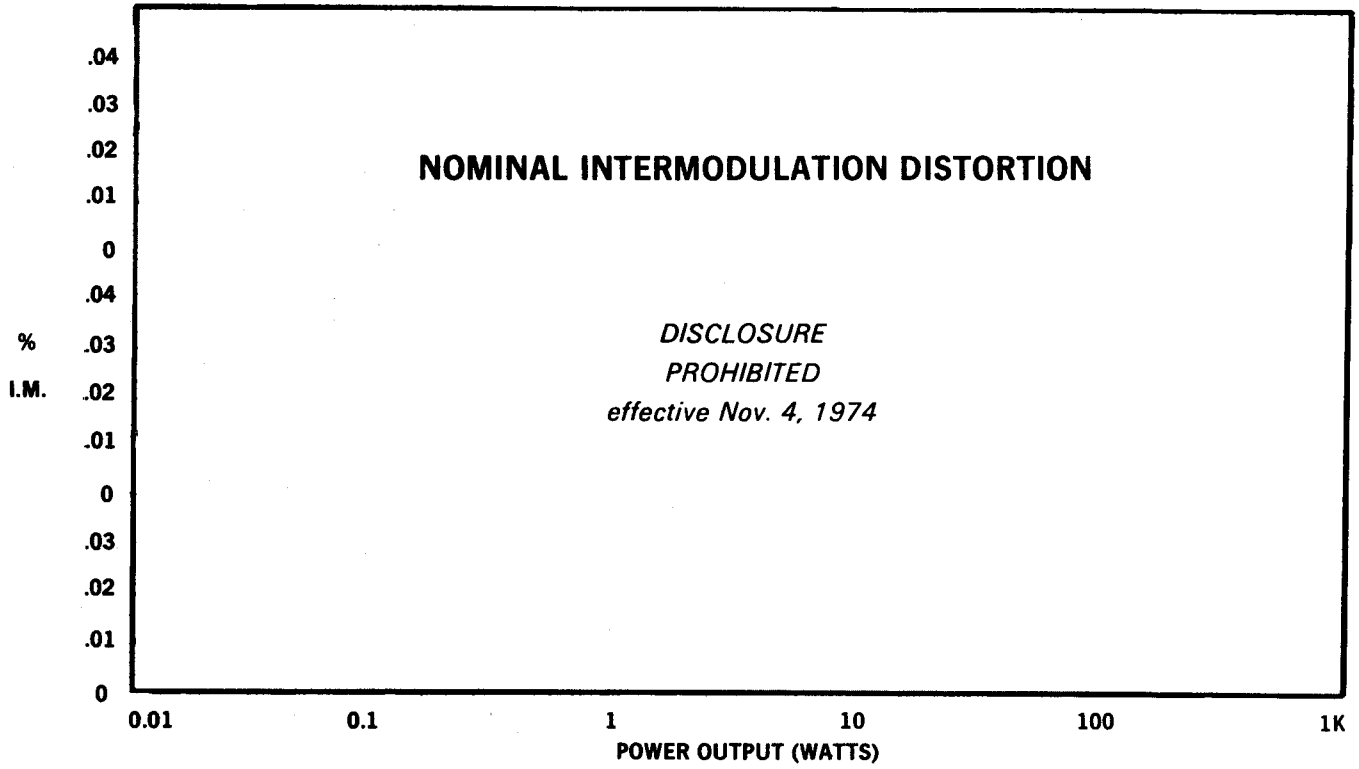

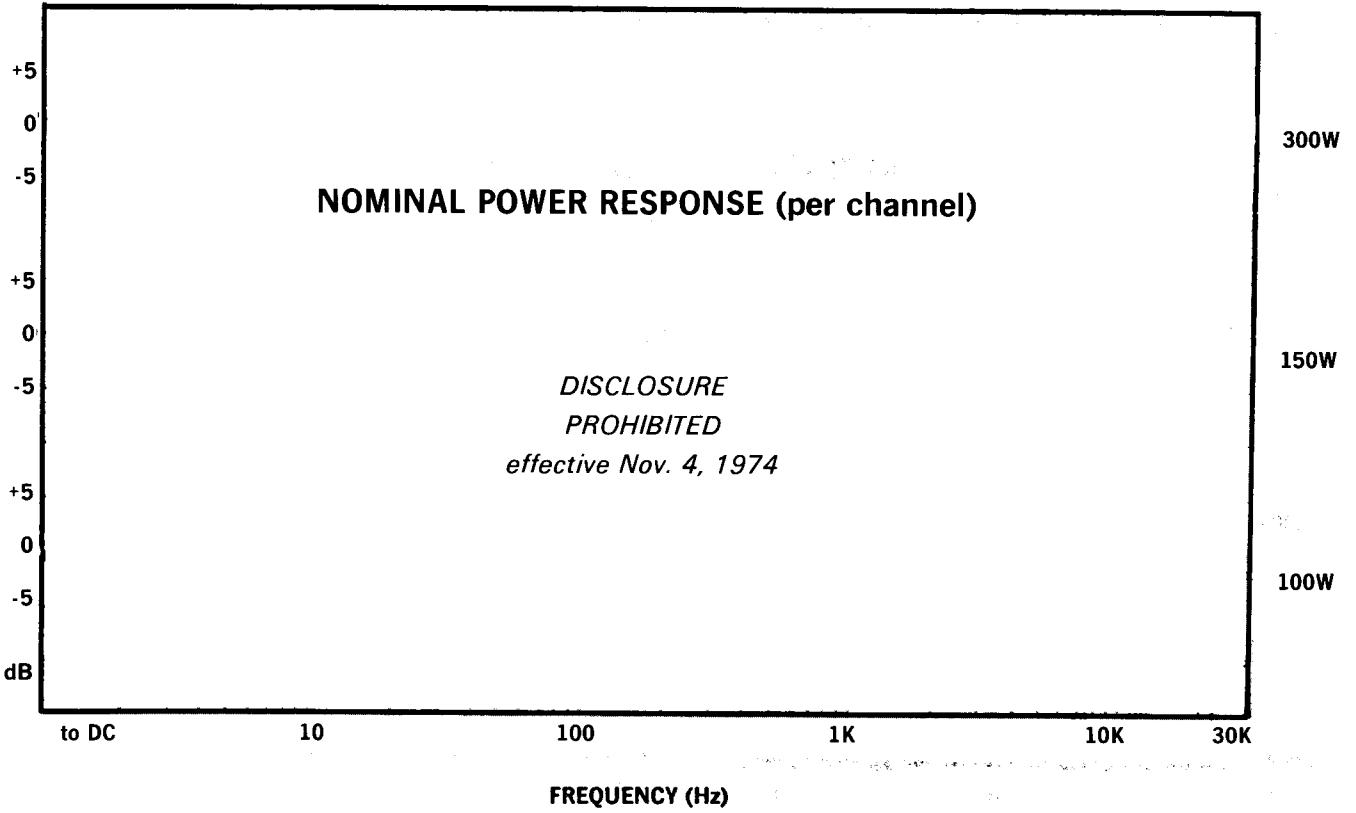
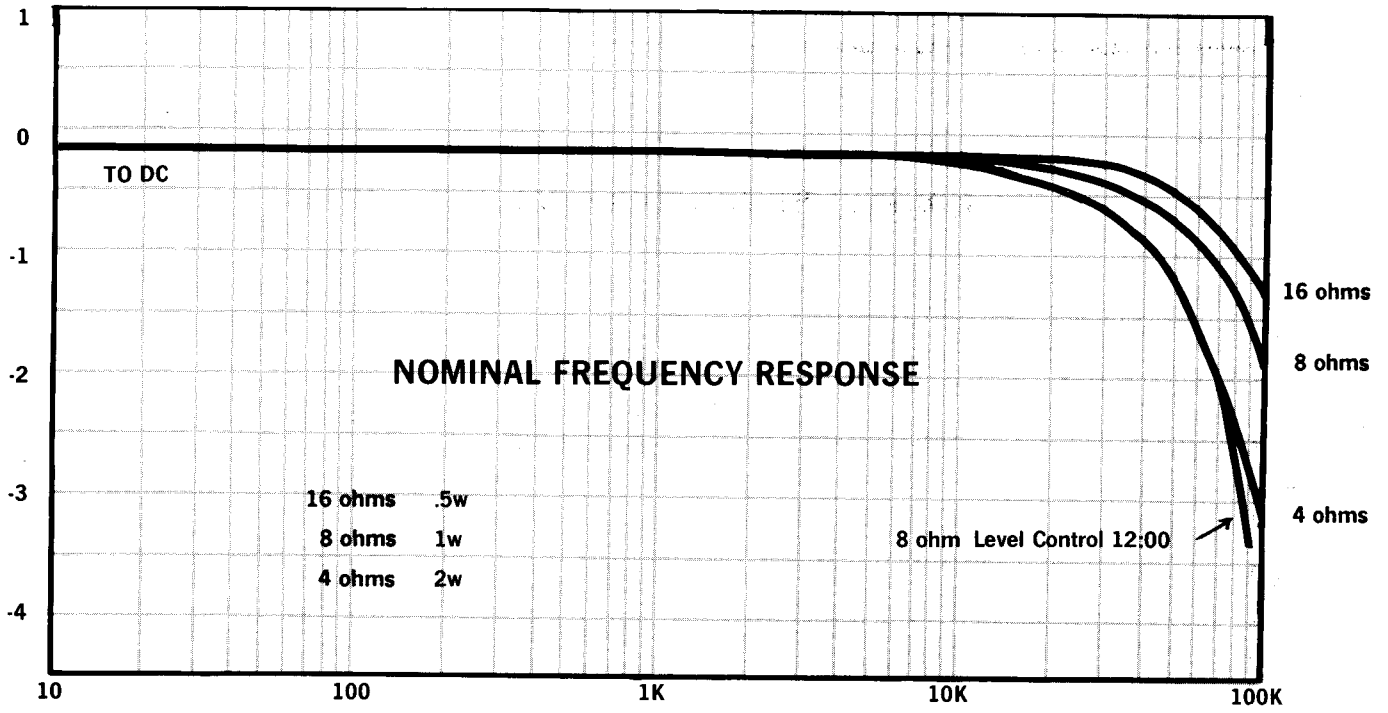

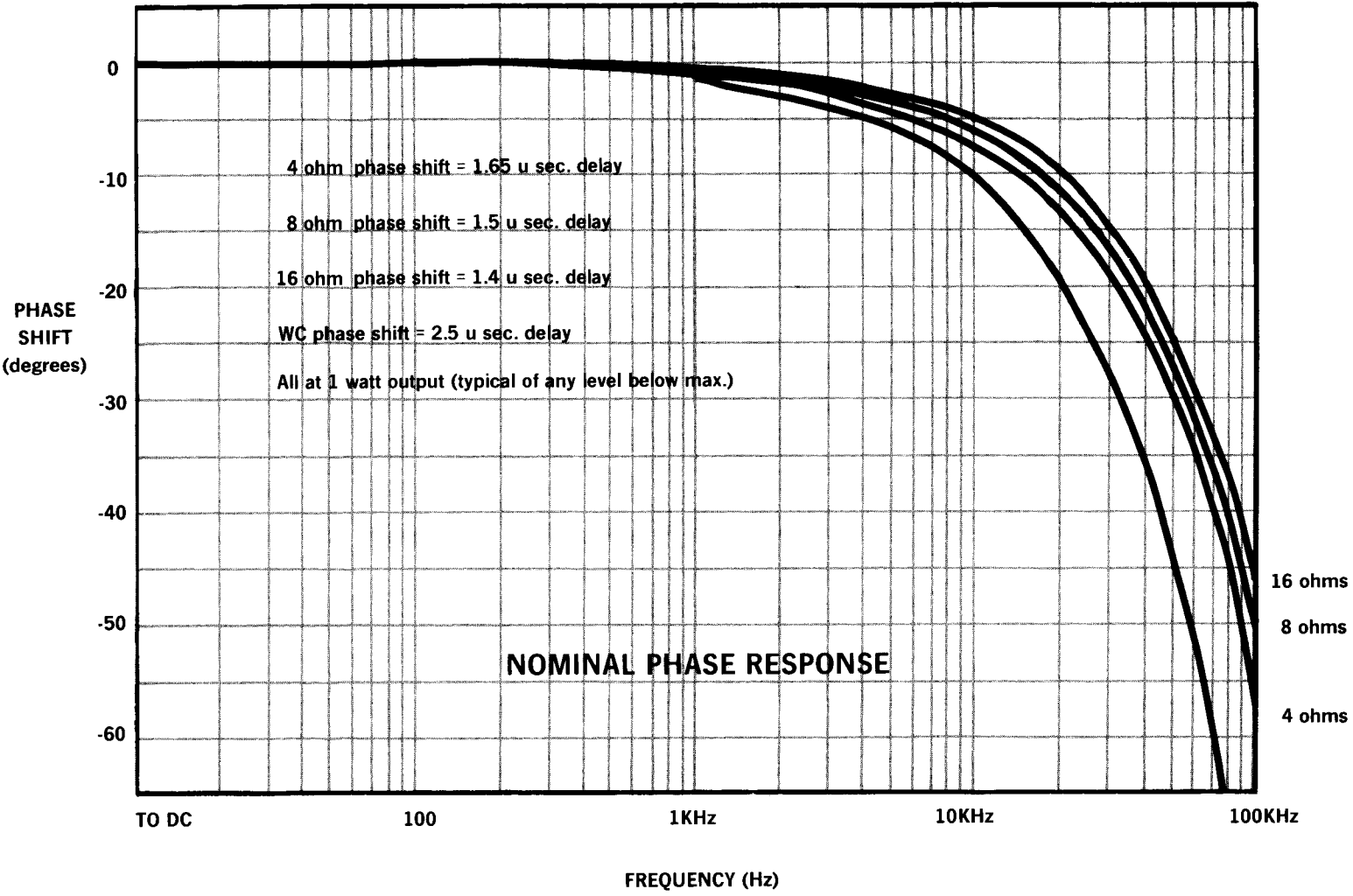

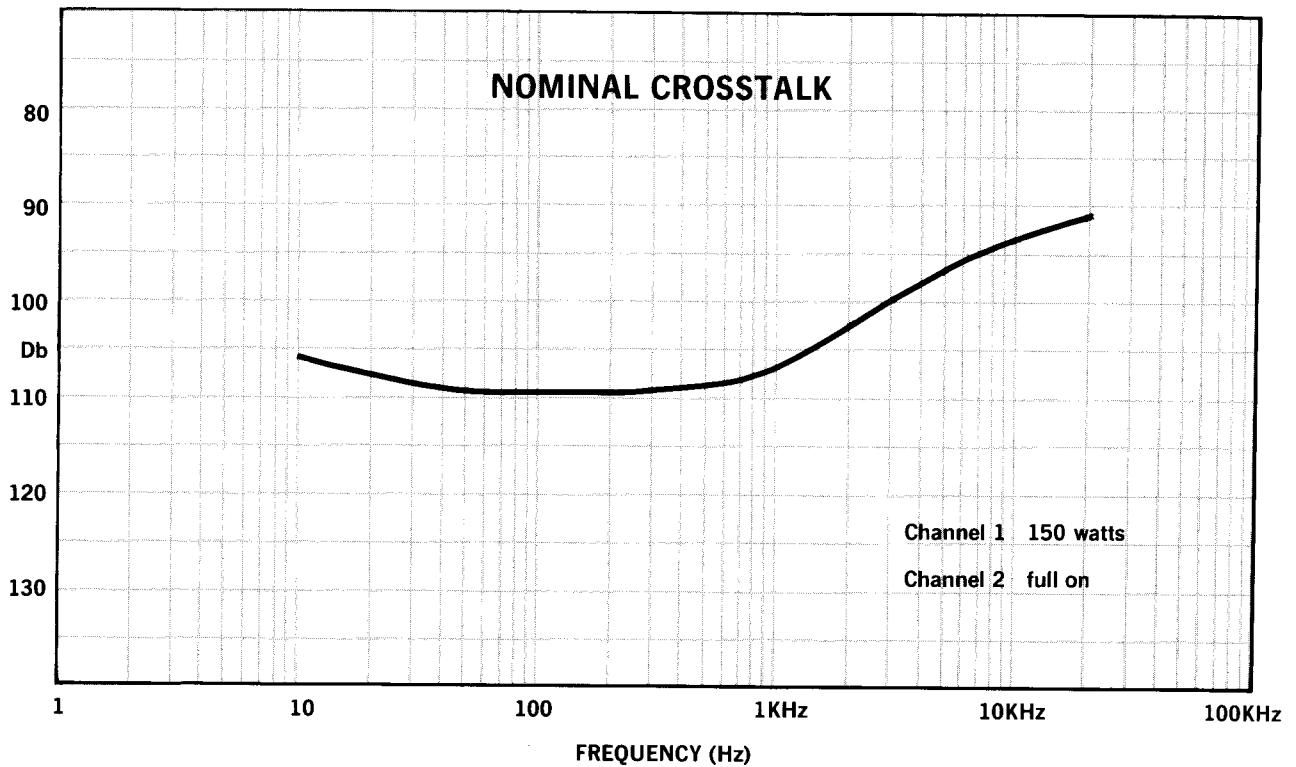
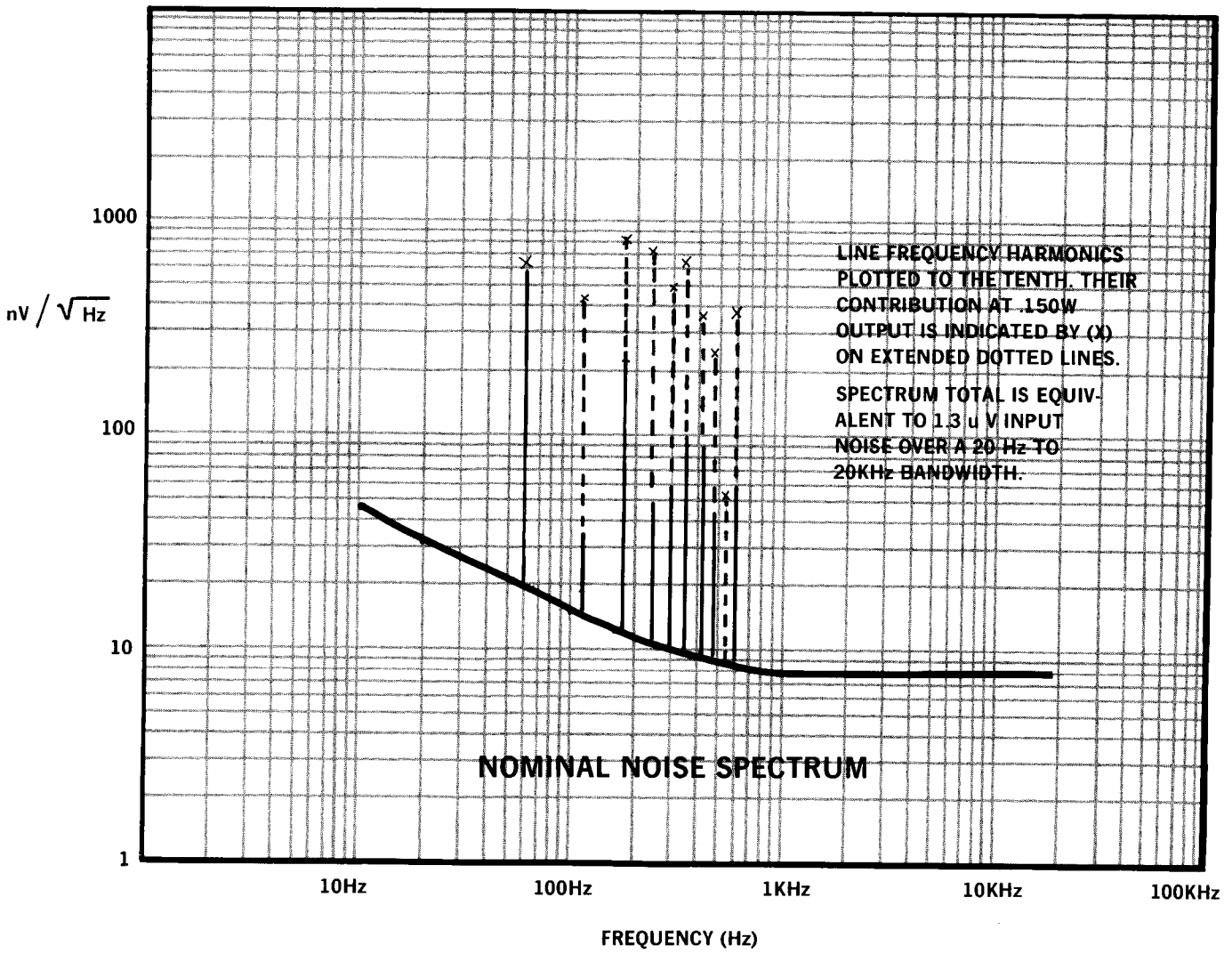

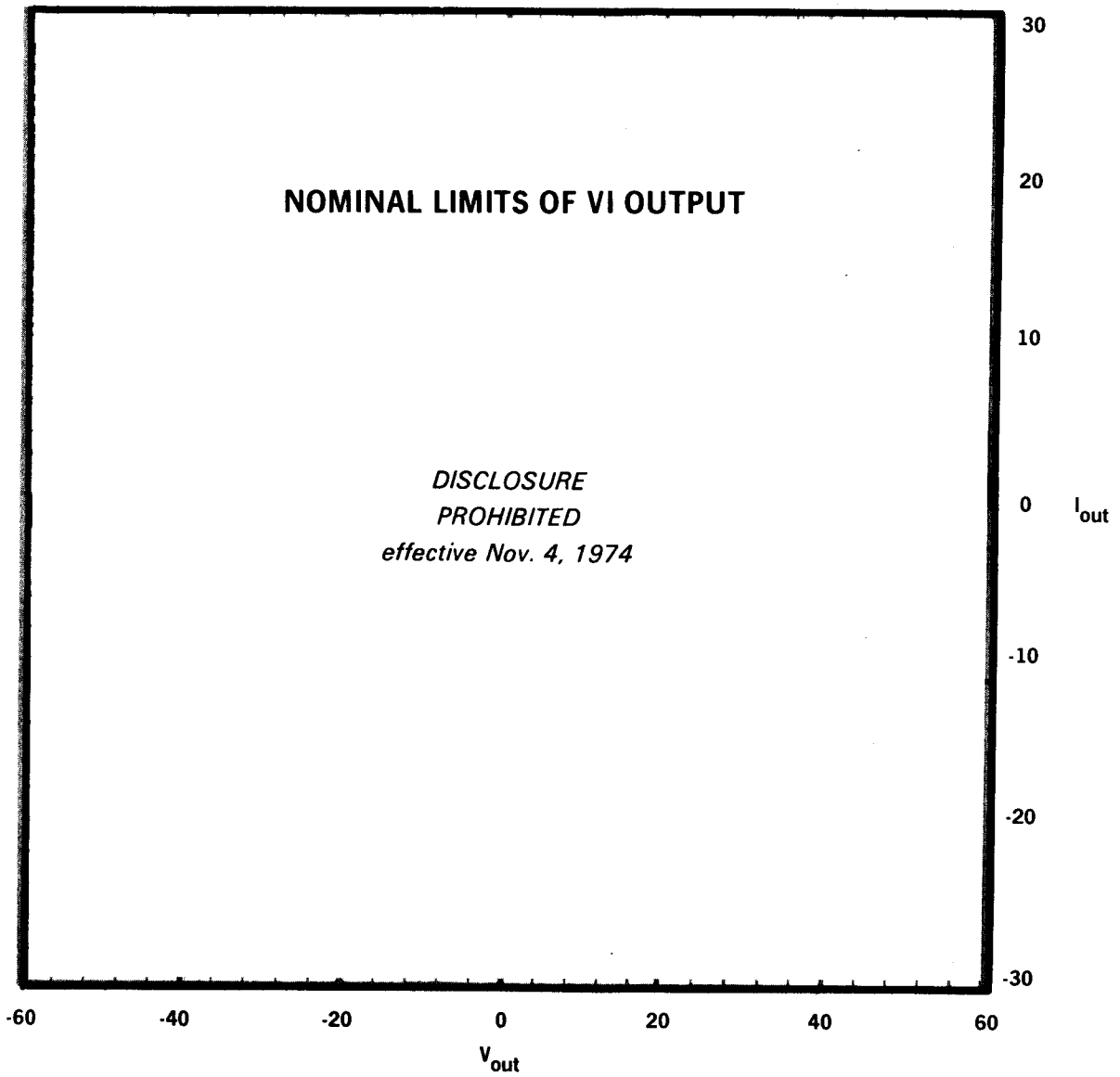

●●● AC LINE FUSE BLOWS
(DC SINGLE CHAN.) BLOWS
AT 10A DC IF BOTH
CHANNELS ARE DRIVEN EQUALLY

--- MID-FREQUENCY BURST LIMIT

XXX SHORT CIRCUIT CONTINUOUS LIMIT

☒ AREA OVER WHICH LIMITER (AC)
VARIES (SIGNAL DEPENDENT)

●●● MAX. AC (LIMIT (Z_L , V OUT (SINE) AT
MAX.)

— MAX. CONT. AC POWER
($Z_A = 2.75 \Omega$)

--- HIGH FREQUENCY LIMIT

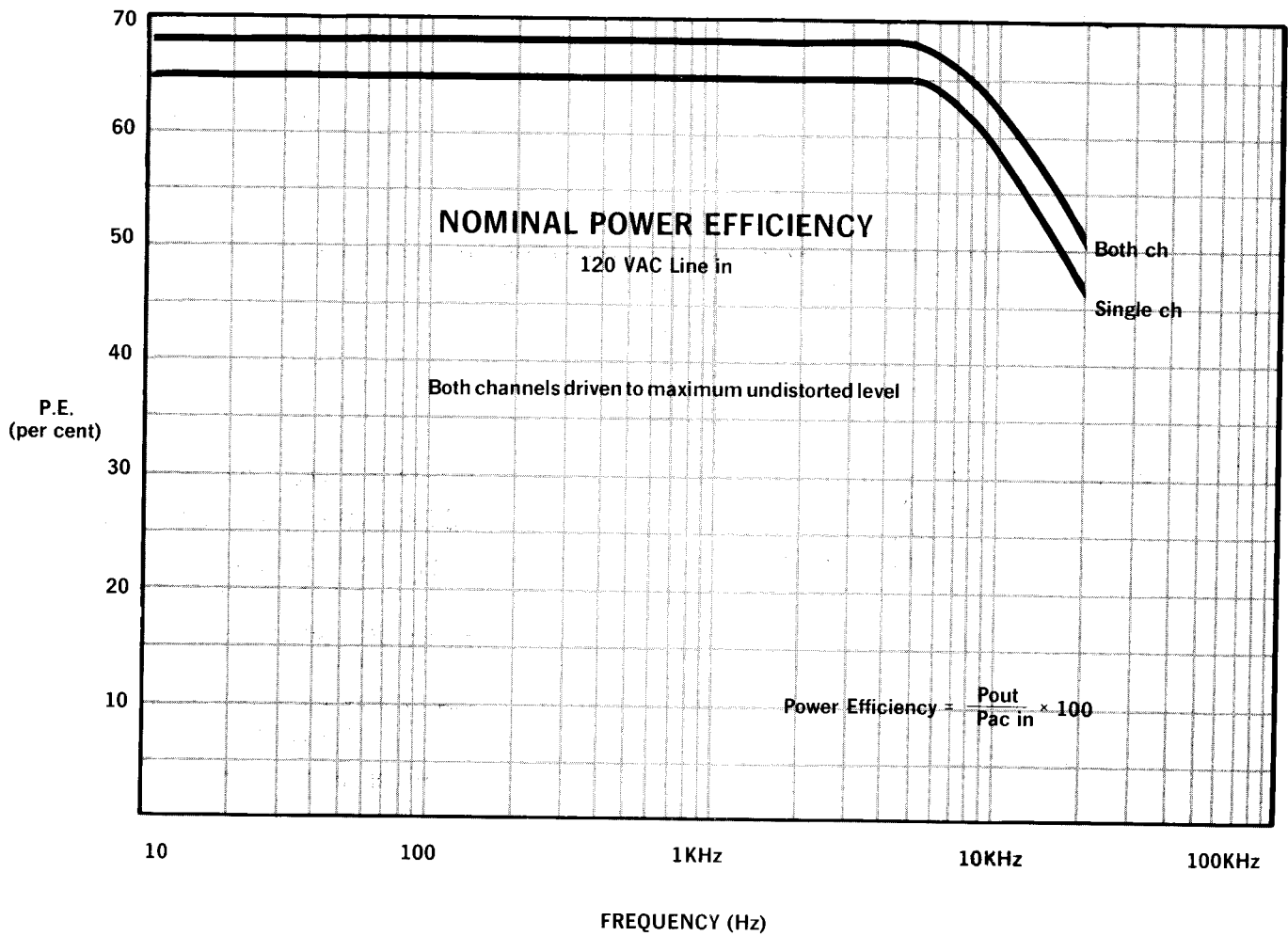
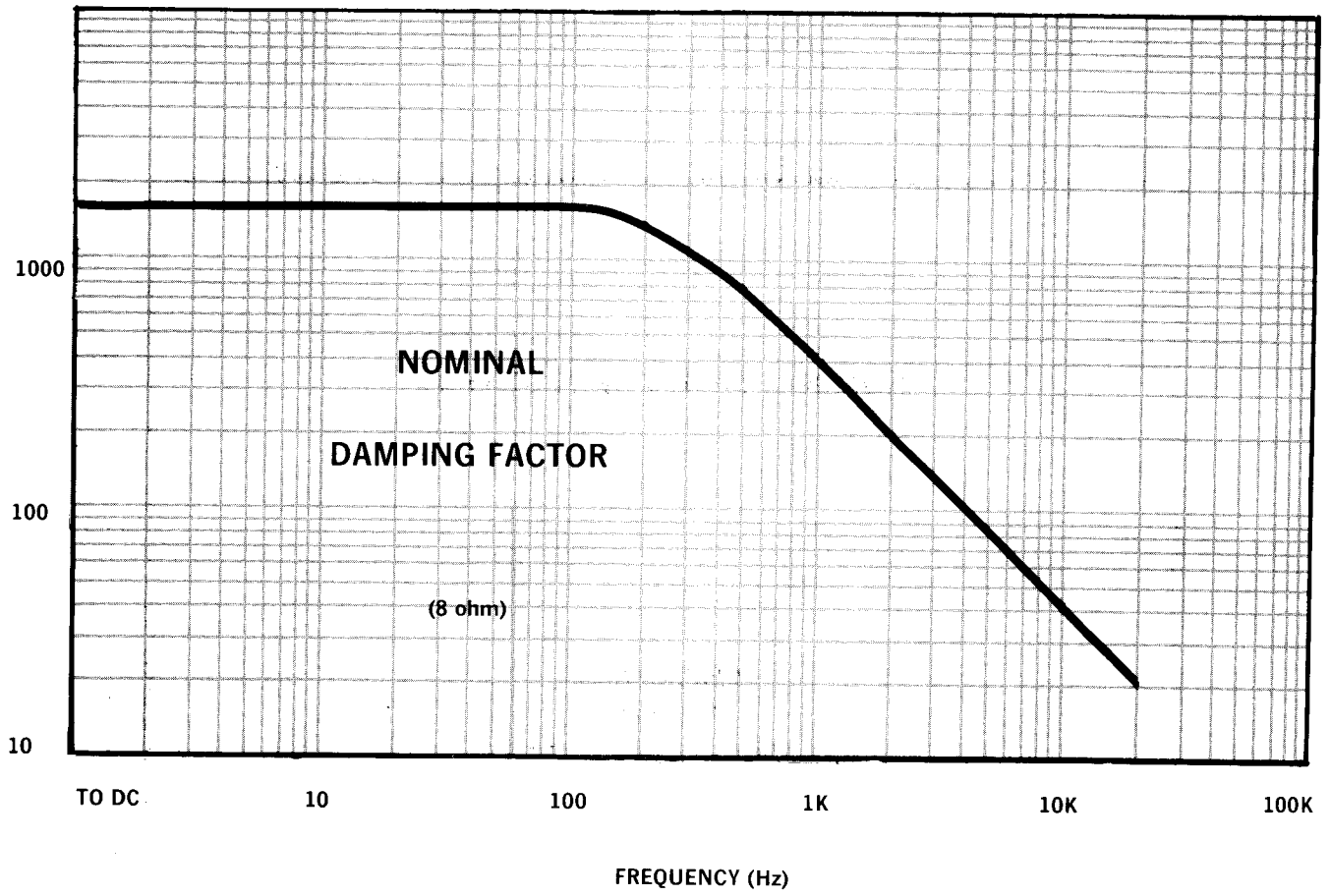

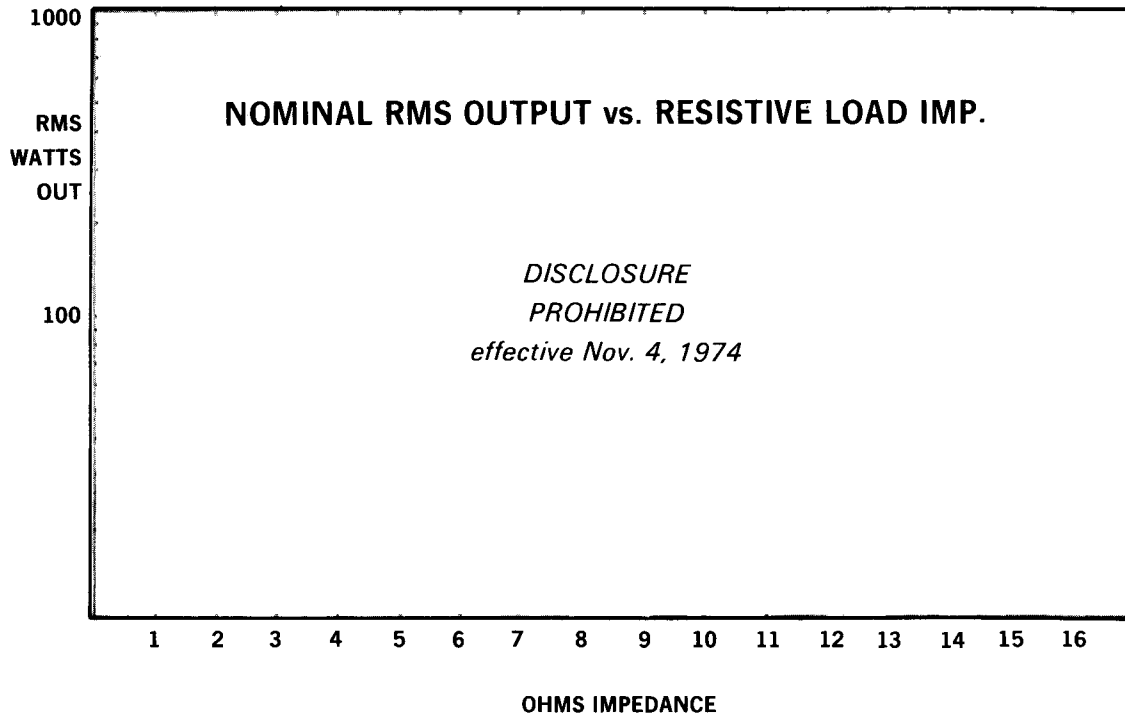
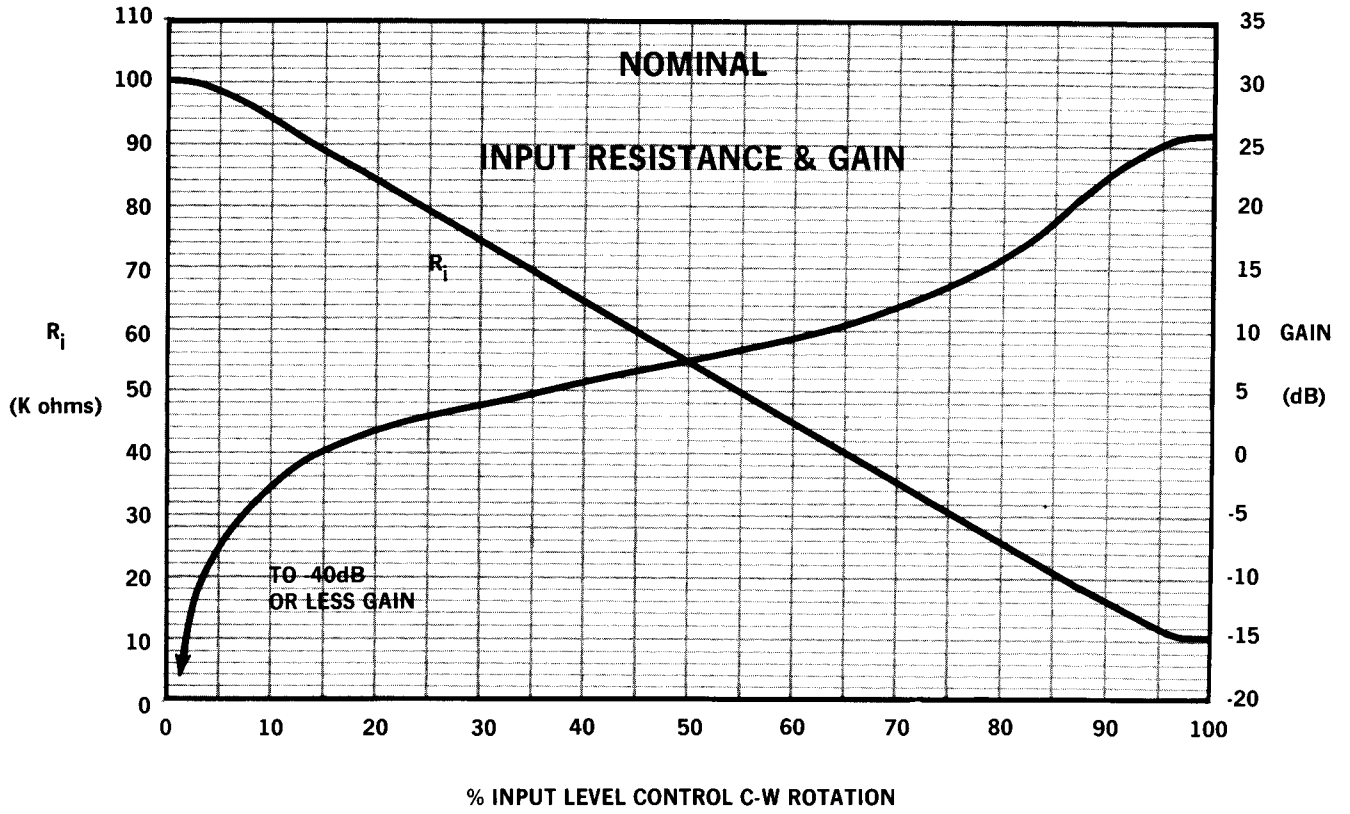

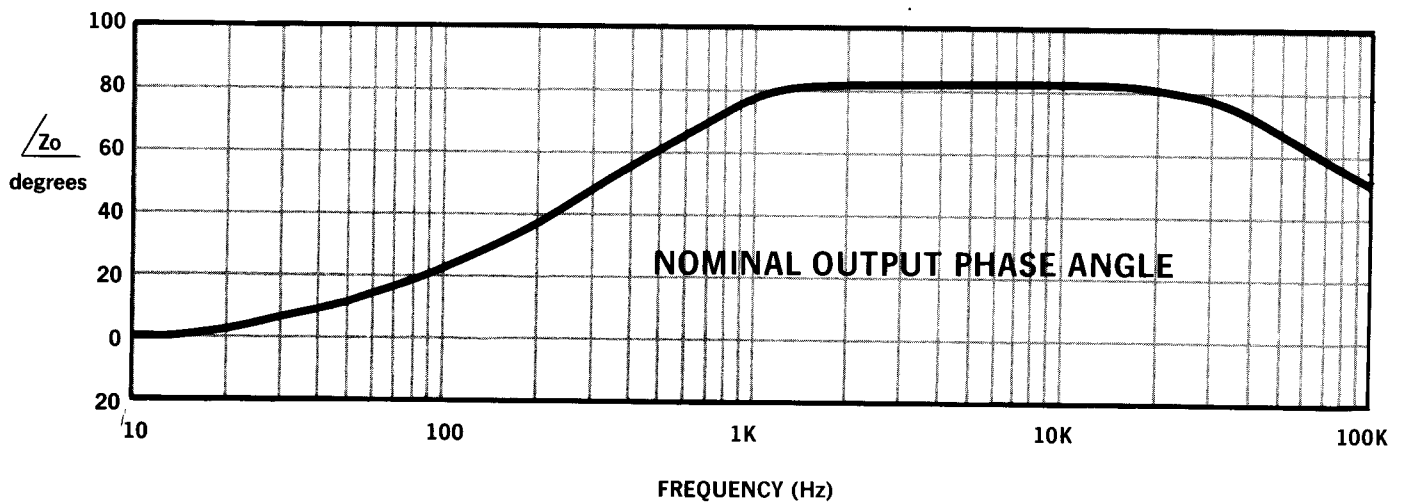
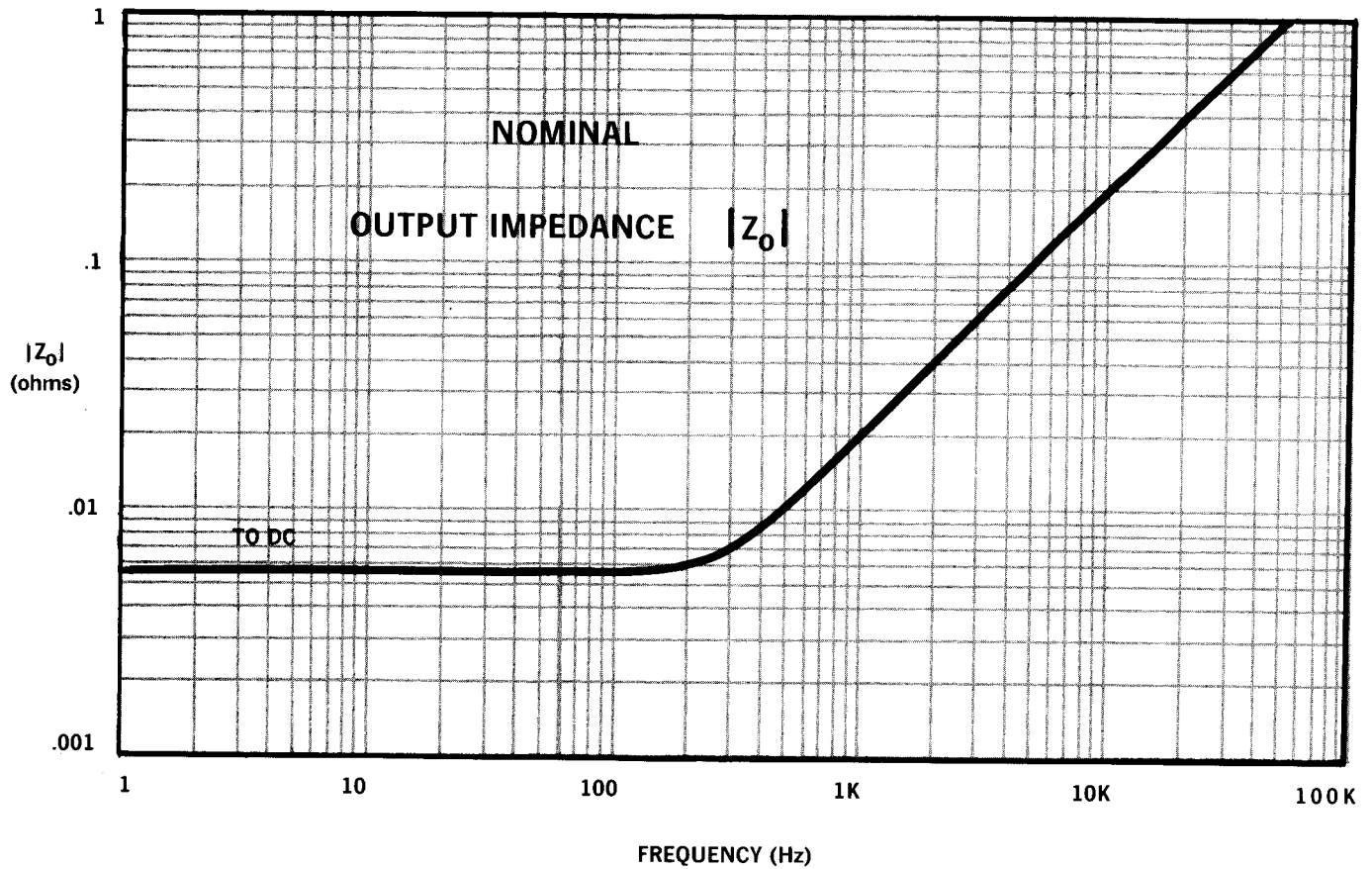

1.3 WARRANTY

CROWN guarantees this equipment to perform as specified. CROWN also warrants the components and workmanship of this equipment to be free from defects for a period of 90 days from date of purchase.

This warranty does not extend to fuses, and/or component or equipment damage due to negligence, misuse, shipping damage or accident; or if the serial number has been defaced, altered or removed.

An application for a FREE 3-year WARRANTY TITLE is included with this manual. Upon receipt of this completed form, CROWN will issue the Warranty Title — subject to the conditions contained therein. This title applies to the original end-purchaser and will be issued only upon the receipt of the application.

We urge that you take full advantage of this coverage — fill in and mail the application now!

2.1 UNPACKING

As soon as the amplifier shipment is received, please inspect for any damage incurred in transit. Since the unit was carefully inspected and tested at the factory, it left the factory unmarred. If damage is found, notify the transportation company immediately. Only the consignee may institute a claim with the carrier for damage during shipment. However, CROWN will cooperate fully in such an event. Be sure to save the carton as evidence of damage for the shipper's inspection.

Even if the unit arrived in perfect condition — as most do — it is advantageous to save the packing materials. They will prove valuable in preventing damage should there ever be occasion to transport or ship the unit. Note the carton and internal pack — each is designed for protection during transit, particularly of the power transformer weighing over 25 lbs. *Do not ship the unit without this factory pack!*

Be sure to return the warranty registration form to the factory within ten days for the full warranty coverage.

2.2 MOUNTING

The DC-300A is designed on a standard 19 inch rack-mounting format. However, it may be custom mounted if sufficient support is provided. For dimensions see Fig. 2-1. In any circumstance, sufficient ventilation must be provided for the unit. Good ventilation practice allows air to flow completely under, around, and through the amplifier. If the unit is placed above a horizontal surface,

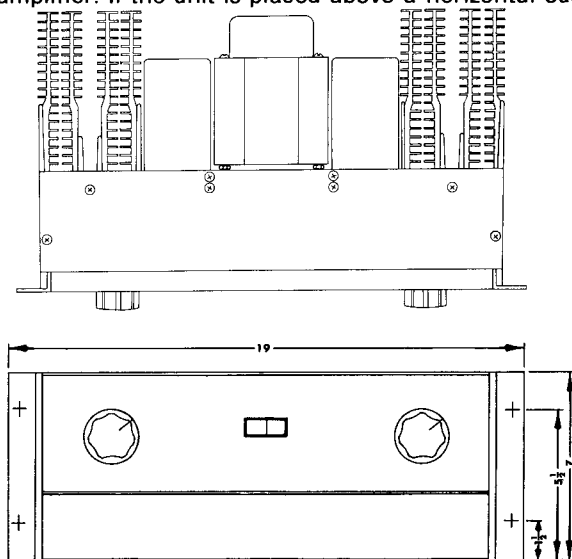

FIG. 2-1
MOUNTING DIMENSIONS

an air space should be allowed above and below the unit. If sufficient ventilation is not provided, the unit will intermittently turn off due to the built-in thermal protection. Such a condition (if observed) will also be accompanied by a warm front-panel due to the integral heat-sinking employed in the amplifier.

Applications requiring long sustained signals at high power levels may require the use of a cooling fan.

2.3 NORMAL HI-FI INSTALLATION

1. Remove output covers, exposing dual binding-posts. Two-conductor speaker cables must connect to the OUTPUTS using terminal lugs, tinned ends, or the special "banana" plugs supplied with the DC-300A. Connect the in-line fuses as recommended in the Accessory Bag and Fig. 2-2 Overleaf. (Not needed with CROWN speakers.)

2. Since the DC-300A is a "basic amplifier," the main outputs of the control-center or "preamplifier" must be connected via shielded audio-cables to the two jacks marked INPUT. Use RCA-pin at preamp and standard 1/4 inch phone-plug at the DC-300A.

The two cables should be tied parallel along their entire length, using the accessory cable ties.

3. U/L requirements specify a 3-wire AC power connector; however, proper connections to a switched outlet on the control center require the use of a 3-to-2 wire adapter. NOW, plug the AC into a *switched* outlet on the control center.

4. Your Control Center may now be turned on. Then advance the DC-300A Input-Gain Controls about 1/2-open (150° clockwise).

When using the CROWN IC-150 Control-Center, the LOUDNESS should attain almost full rotation (2 to 4 o'clock) for loudest "concert-hall" volume. If at 3 o'clock the volume is low, increase the DC-300A input gain controls; if too high, decrease the DC-300A gains.

To assure maximum enjoyment and full speaker protection, read the following detailed sections on OUTPUTS, INPUTS and Chapter 3—OPERATION.

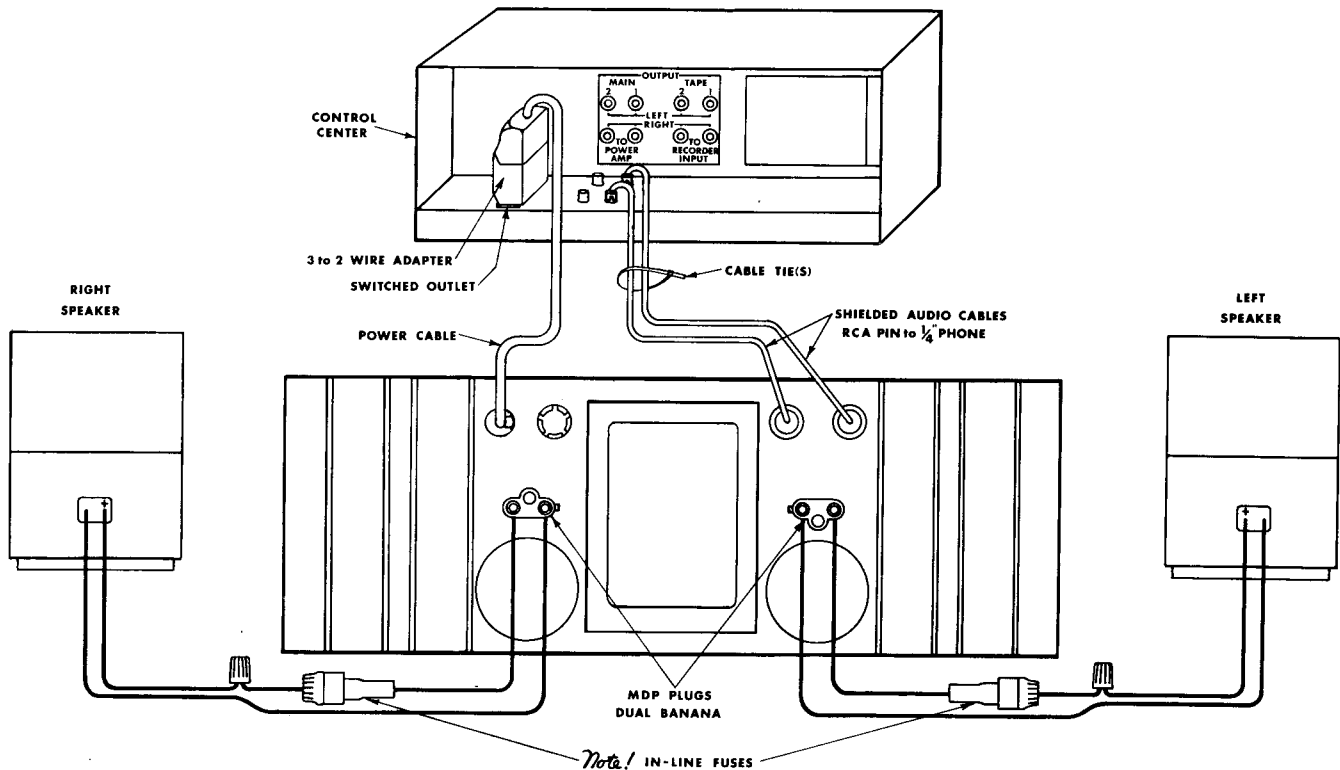

FIG. 2-2
NORMAL HI-FI HOOK-UP

2.4 CONNECTING OUTPUT LINES

Input and output connectors are located on the back of the chassis as shown in Fig. 2-3.

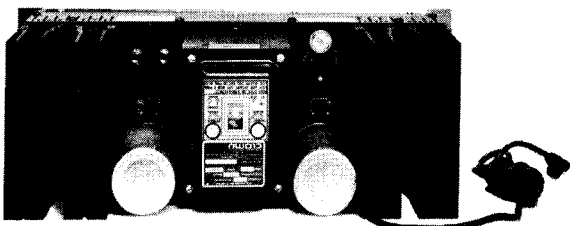

FIG. 2-3
REAR VIEW OF CHASSIS

It is always wise to remove power from the unit and turn the input level controls off while making connections,

especially if the load is a loudspeaker system. This will eliminate any chance of loud blasts. **CROWN is not liable for damage incurred to any transducer due to its being overpowered! (CROWN speakers excepted.)**

Before making connections, it is recommended that the operator familiarize himself with the amplifier's protective system. See Section 3.2. Section 3.3 entitled "Operating Precautions" should also be read.

Because of the location of the output connectors (color-coded binding posts), it will be easiest to make these connections first. High-quality, dual "banana" plugs are the preferred connections for permanent installations, critical applications, and when testing the amplifier.

Because the output wire gauge and length raises the resultant source impedance or lowers the Damping Factor by adding its series resistance, the nomograph (Fig. 2-4)

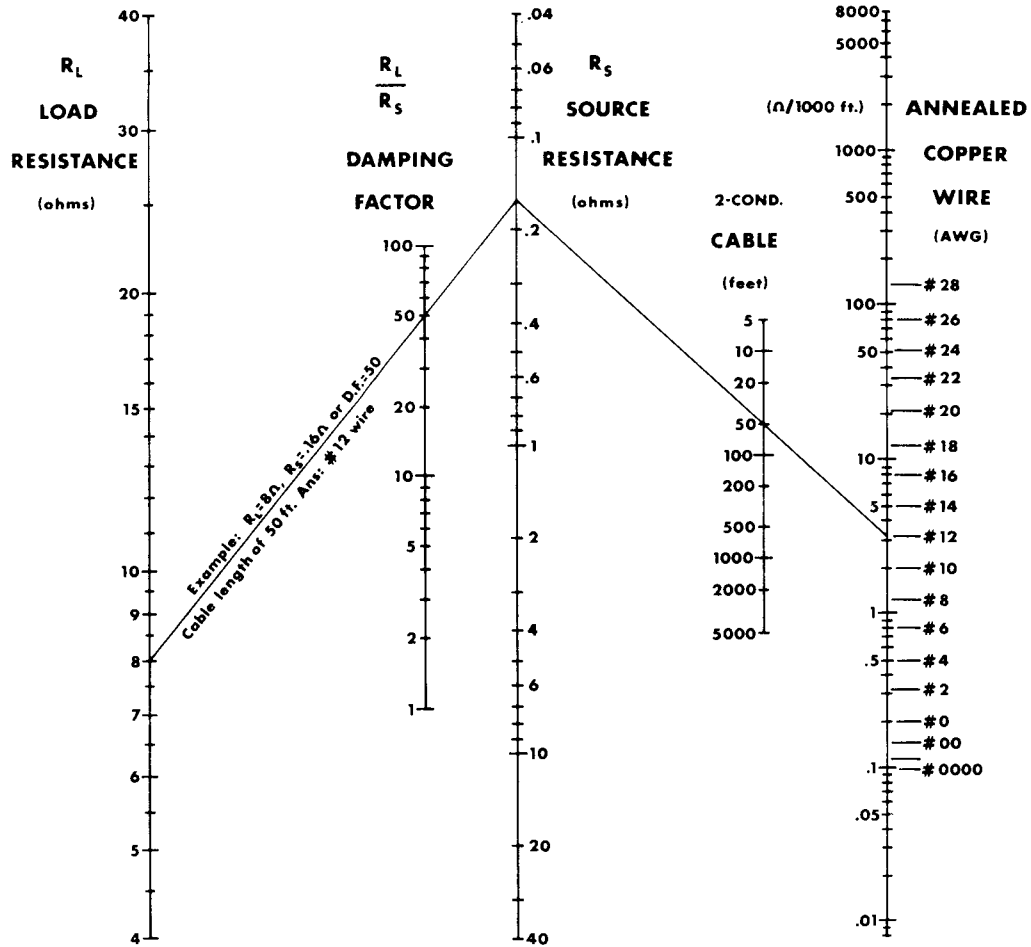

FIG. 2-4
 SOURCE RESISTANCE AND DAMPING FACTOR VS. LENGTH AND SIZE OF OUTPUT LEADS

is provided for wire selection. For dynamic moving-coil loudspeakers the value of R_L should preferably be that measured by an ohmmeter across the voice coil, rather than the manufacturer's rating. For electrostatic speakers and such, the manufacturer's rated impedance should be used for R .

If the load (matching transformer, inductance, or full-range electrostatic speaker system) appears as a short-circuit at low frequencies, a large non-polarized capacitor (paralleled with a resistor) should be placed in series with the load.

For electrostatic speakers (if the manufacturer has not provided a capacitor) an external non-polar capacitor of 590-708 mfd and 4 ohm power resistor should be placed in series with the plus (+) speaker lead. This will prevent large low-frequency currents from damaging the electrostatic transformer or from unnecessarily activating the DC-300A's protective systems. An effective test to determine if such parts are needed is to

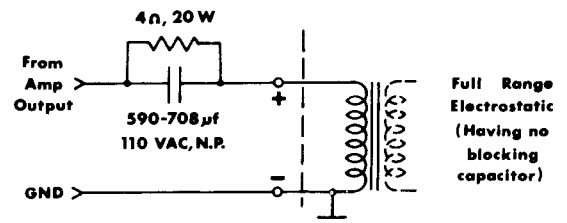

FIG. 2-5
 SCHEMATIC FOR FULL RANGE ELECTROSTATIC SPEAKER CONNECTIONS

measure the DC resistance between the output terminals with an ohmmeter. If the resistance is less than 3 ohms, the parts should be added as shown schematically in Fig. 2-5.

When selecting connectors for the output lines, the following general precautions apply (with all power connectors):

1. A male plug, carrying signal, must not be on the far end of the line where it can be exposed, giving rise to both shock and short-circuit hazards.

2. Connectors which might accidentally cause the two channels to be tied together during making and breaking of connection should not be used. A common example is the standard 3-circuit 1/4 inch phone jack and plug when wired for stereo sound.
3. Connectors which can be plugged into AC power receptacles should *never* be used.
4. Connectors having low-current-carrying capacity are "verboten."
5. Connectors having any tendency to short, or having shorted leads, are inadvisable.

Most commercially-available headphones employ a 3-circuit 1/4 inch phone plug which violates condition number 2. This is no handicap if a pad is inserted between the amp and jack, which is the only sensible thing to do, when such a large amplifier is coupled to such a small transducer. If this precaution is ignored, not only may the transducer be burned out but permanent hearing loss could result. The recommended pad is shown in Fig. 2-6.

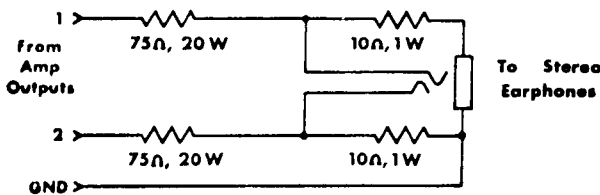

FIG. 2-6
SCHEMATIC OF EARPHONE PAD

2.5 CONNECTING INPUT LINES

Connecting the inputs will require avoiding three basic dangers: Undesirable signals to the inputs, "ground loops," and feedback from output(s) to input(s).

For loudspeaker-driving applications, the input should be free of any DC, as this could cause overheating of the loudspeaker voice coil. A simple visual test for DC on the inputs (providing the woofer is visible) is to slowly turn up the input level control with the amp on and watch for any displacement of the cone. If very much displacement is observed, the DC content of the input may be excessive and require a blocking capacitor. The graph of Fig. 2-7 indicates the effect of the size of the blocking capacitor on the frequency response. Only a low-leakage type paper, mylar, or tantalum capacitor should be used for this purpose.

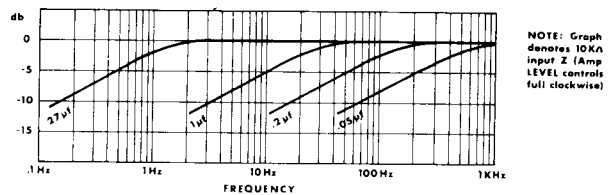

FIG. 2-7
TABLE FOR SELECTION OF
INPUT DC BLOCKING CAPACITOR

If large amounts of ultrasonic or RF frequencies are found on the input, such as bias from tape recorders, etc., a low-pass filter should be placed on the input. While practically-obtainable RF input levels will not damage the amplifier, they may cause burn-out of tweeters or other sensitive loads, activate the amplifier's protective systems, or cause general overload in the controlled-slewing-rate stage of the amp (which is employed to provide RF overload protection). The following filters are recommended for such applications.

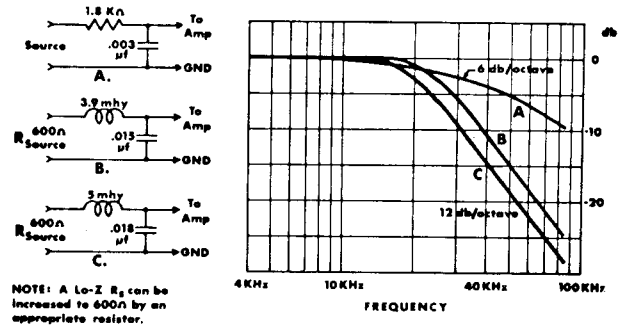

FIG. 2-8
LOW-PASS FILTER FOR SEVERE RF AT INPUTS

A second problem area is "ground loops" — electronic jargon for undesirable circulating currents flowing in a grounding system. A common form of loop (possibly resulting in hum in the output) is a pair of input cables whose area is subjected to a magnetic hum field. In practice, both cables should lie together along their length, and away from the power transformer. Tying the input and output grounds together may also form a ground loop.

A third problem (with input and output grounds together, as in testing or metering) is feedback oscillation, from load current flowing in the loop. In industrial use, even the AC power line may provide this feedback path. Proper grounding, and isolation of inputs of common AC line

devices is good practice. Refer to Section 4.2, par. 5 for testing precautions.

An extremely common form of this problem is encountered when using electrostatic loudspeakers or any other kind of load that is joined to the AC power mains. Capacitive coupling through the load's supplies may allow the amplifier's output to be fed through the AC mains and into the grounds of input equipment resulting in a system oscillation.

To combat the problem, first try reversing the speaker leads on all channels if possible. If this does not solve the problem, try grounding the power amplifier to the AC ground with its 3 wire plug. (A ground loop may result through an FM tuner with an earth-grounded antenna system when deploying the 3 wire plug. The use of .005 uF disc capacitors in series with the FM antenna leads will eliminate this problem.) All hookup (interconnecting) cables should of course be as short as reasonably possible, and a turntable baseplate ground should always be brought to the phono preamp with a separate ground wire, never via the input cable ground. If the oscillation still persists, start removing input devices, working towards the amplifier until the oscillation disappears. This will identify the point of feedback. If an offending piece of equipment is found it should be inspected for unnecessary AC line-to-ground capacitances such as line filters, etc. If possible such should be removed. Such devices should never be found in the load, although it is true that some RF loudspeakers have used such filters to reduce RFI.

2.6 CONNECTING POWER

The amplifier is furnished with a three-wire AC plug as standard equipment. Adapters are readily available commercially for adapting this to a two-wire system if necessary.

The amplifier offers five standard line-voltage connections: 120, 128, 240, 248, and 256VAC. The tag attached to the line cord indicates for which voltage the amplifier is connected. Most units are connected for 120VAC. If the amplifier is used on lines which at *any* time exceed 130VAC, the unit *must* be reconnected for 128VAC.

When testing the amplifier, the line voltage must be the peak equivalent to a sinusoid of the indicated line voltage when at full load. Line regulation problems can introduce serious errors in the measurements on an amplifier of this size.

Only a competent technician should attempt alteration of the line voltage connections.

In order to change the voltage, it is first necessary to carefully detach the bottom cover from the unit. On the back of the board-mount subchassis a terminal strip with solder-on jumpers is used to make the line-to-transformer primaries connections (see Fig. 2-9).

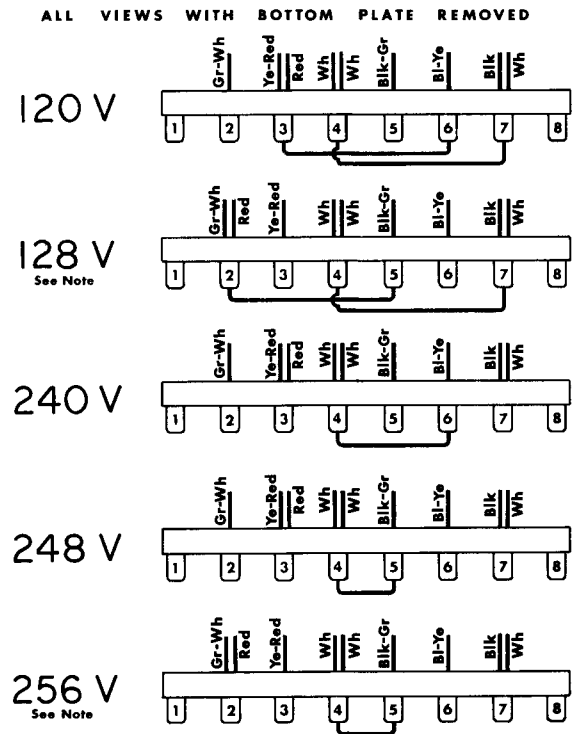

NOTE: The 128V and 256V connections require the changeover of the RED wire from TB-3 to TB-2. Therefore, the Front Panel, control circuit-board and shield must be carefully removed for access. When replacing shield, **use care** in locating so that **on-off switch** locates properly in Front Panel opening!

FIG. 2-9
TABLE OF LINE VOLTAGE CONNECTIONS

3.1 CONTROLS AND ADJUSTMENTS

OPERATING INSTRUCTIONS

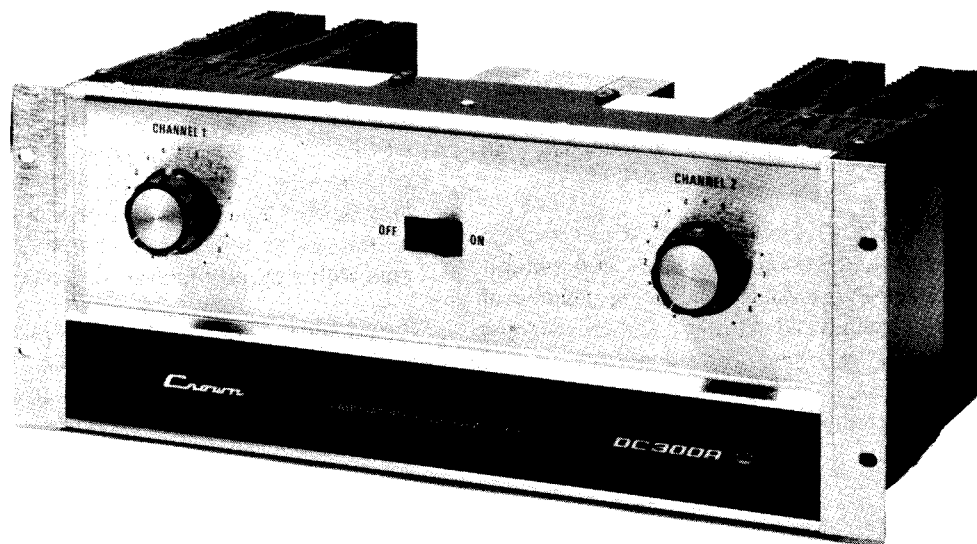

FIG. 3 - 1
OPERATING CONTROLS

The DC-300A contains all the facilities essential for a high performance amplifier.

On the front panel are located independent level controls, a power switch, and pilot light. There is an AC line fuse on the rear of the unit.

The level control should be adjusted for the desired amplifier gain or output level. When the control is fully CW, the gain is 26db as determined by precision 1% resistors in the DC-300A's feedback loop.

The DC balance controls located behind the front panel seldom, if ever, need adjustment. *Only* in the most critical applications will they need adjustment (*not* "hi-fi" or similar applications). To adjust the DC balance controls, use the following procedures (see Circuit Board layout in Section 4):

1. Make sure amp has been allowed at least 15 minutes of warm-up.
2. Set corresponding level control fully CCW.
3. Remove input signal from corresponding input.
4. Place sensitive DC voltmeter across output.
5. Adjust output balance control using small flat-bladed screwdriver for zero reading on voltmeter.
6. Turn level control CW to 12 o'clock.
7. Adjust input balance control using small flat-bladed screwdriver for zero reading on voltmeter.

The DC balance controls are now adjusted.

3.2 THE PROTECTION MECHANISMS

The DC-300A is protected against all the common hazards which plague highpower amplifiers, including shorted, open, and mismatched loads; overloaded power supplies; excessive temperature; chain destruction phenomena; input overload damage; and high frequency overload blowups.

Protection against shorted and low impedance loads is provided by the Signal Programmed Automatic Current Executor (SPACE control). It functions as an automatic current limiter at audio frequencies whose value of current limiting threshold is dependent on the history of the output signal. Output current causes the threshold to decrease while output voltage causes the threshold to increase. The no signal threshold is high enough to allow tone bursting, (even into 4~) without premature limiting as is found in some recent products of other manufacturers.

Since the limiter has no instantaneous response to output voltage, flyback transients do not appear in the output when limiting occurs on inductive loads. Flyback transients are a necessary response of a VI limiter (sometimes misnomered an "Energy Limiter") when limiting drive to an inductive load. The actual response of the flyback pulse is that the amplifier yields to the load resulting in a pulse emanating from the load which returns the inductive energy of the load to the opposite polarity power supply of the amplifier as that supply that produced the excessive output. The audible effect of flyback pulses is to produce a rasping, popping sort of sound which is not pleasing.

A current limiter will not yield to the load but will sustain the constant current demands of the inductive load without flyback.

Early amplifier designs frequently employed fixed current limiters but had serious difficulty with obtaining reliable low frequency output while being capable of full-voltage 4 ohm output. Also, many earlier designs used fragile epi-base or triple diffused outputs, which for reliable performance are poor mates for a current limiter protection scheme. The DC-300A uses eight

150W hometaxial* silicon power transistors per channel, which are the toughest type of audio power transistor yet developed. Their toughness allows the reliable use of a current limiter which when rendered signal variable permits larger power outputs than would be safely allowable with a current limiter of fixed type.

At subsonic frequencies, the SPACE control behaves as a VI limiter and provides the increased protection needed at DC to prevent destruction due to heat buildup in the half of the output stage that is being driven.

*Tradename of RCA

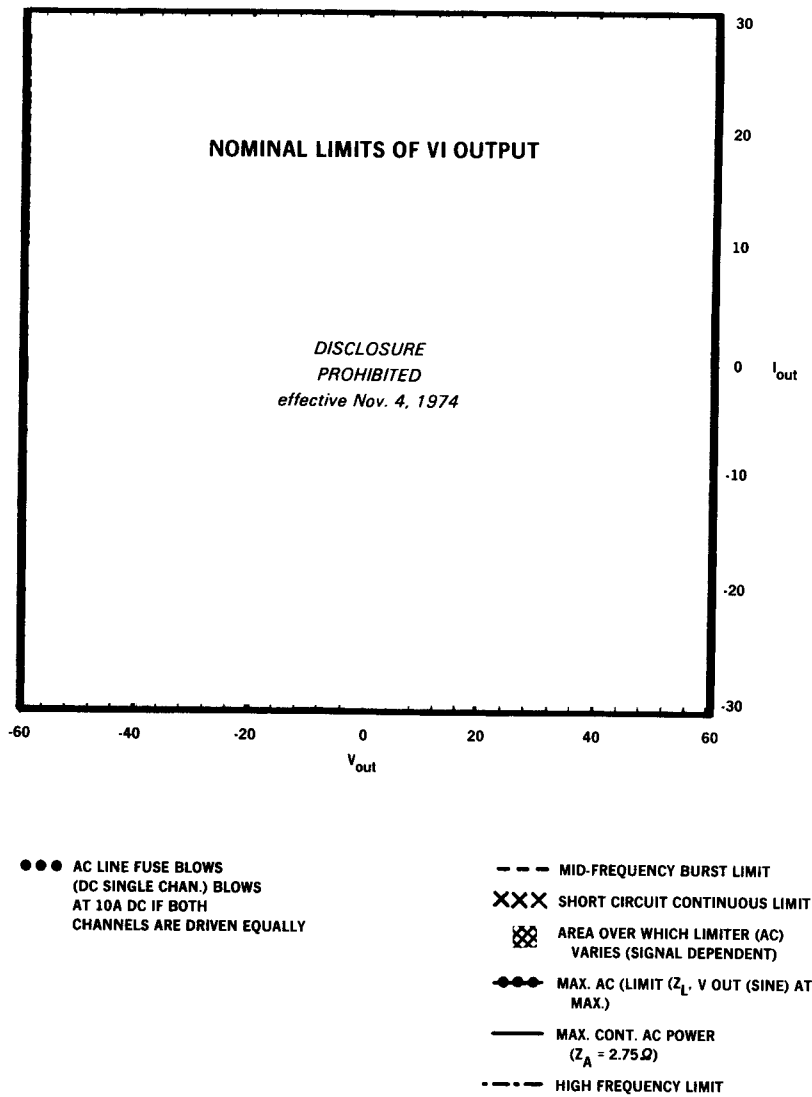

FIG. 3 - 2
GRAPH OF VI OPERATING RANGE OF DC-300A OUTPUT

The fuse inherently protects the power supplies against overload. The AC line for 120, 128VAC is fused with a 10A 250V type AB fuse (on 240, 248VAC, 5A type 3AG 250V).

The use of any other size fuse will invalidate the warranty.

Never change fuses with power applied!

On each heat sink (see Fig. 2-2) is mounted a thermal switch which protects the amplifier against insufficient ventilation. If either heat sink becomes too hot, the AC line power will be interrupted until the temperature falls to a safe level, whereupon power will be automatically restored. When such an event occurs, the external symptoms are: no indication of AC power (by the pilot), and a warm front panel.

All of the amplifier's voltage-amplifier circuitry is designed to be inherently current-limited. Thereby, if any of the devices should fail, (which is extremely unlikely), no damage will occur to the rest of the stages.

The input stage is protected against overdrive damage by a series limiting resistor should the input signal level ever become very excessive.

The amplifier features a controlled slewing-rate which, coupled with the SPACE controller, protects the amplifier from blowups when fed large RF input signals.

3.3 OPERATING PRECAUTIONS

The following are a number of operating precautions given as an aid to understanding proper *and* improper amplifier usage:

1. Use care in making connections, selecting signal sources, and controlling the output level. The loudspeaker you save may be your own. CROWN is not liable for any damage done to loads due to careless amplifier usage or deliberate overpowering (CROWN speakers excepted). For pointers on load protection see Section 3.4.
2. Never parallel the two outputs by directly tying them together or parallel them with any other amp's output. Such connection does not result in increased power output. Damage incurred by such operation is not covered by the warranty.
3. Never drive a transformer-coupled device or any other device which appears as a low frequency short (less than 3 ohm) without a series isolating capacitor.

Such operation may damage the device and/or needlessly waste output power.

4. Do not short the ground lead of an output cable to the input signal ground as oscillations may result from forming such a ground loop.
5. Never remove fuses with power applied.
6. Operate and fuse the amplifier only as set forth in Section 3.2.
7. Operate the amplifier from AC mains of not more than 10% above the selected line voltage and only on 50, 60, or 400Hz AC. Failing to comply with these limits will also invalidate the warranty.
8. Never connect the output to a power supply output, battery, or power main. Damage incurred by such a hookup is not covered by the warranty.
9. Do not expose the amplifier to corrosive chemicals such as soft drinks, lye, salt water, etc.
10. The amplifier is not recommended for high power industrial usage at frequencies above 20KHz.
11. Tampering in the circuit by unqualified personnel or the making of unauthorized circuit modifications invalidates the warranty.
12. Do not expose the output leads to areas likely to be struck by lightning. Such an installation could invalidate the amplifier.

3.4 LOAD PROTECTION METHODS

The most common of all load protection schemes is a fuse in series with the load. The fuse may be single, fusing the overall system. Or, in the case of a multi-way speaker system, it may be multiple with one fuse on each speaker.

Fuses help to prevent damage due to prolonged overload, but provide essentially no protection against damage that may be done by large transients and such. To minimize this problem, high-speed instrument fuses such as Littlefuse 361000 series are most appropriate for such applications. For a nomograph showing fuse size vs. loudspeaker ratings refer to Fig. 3-3.

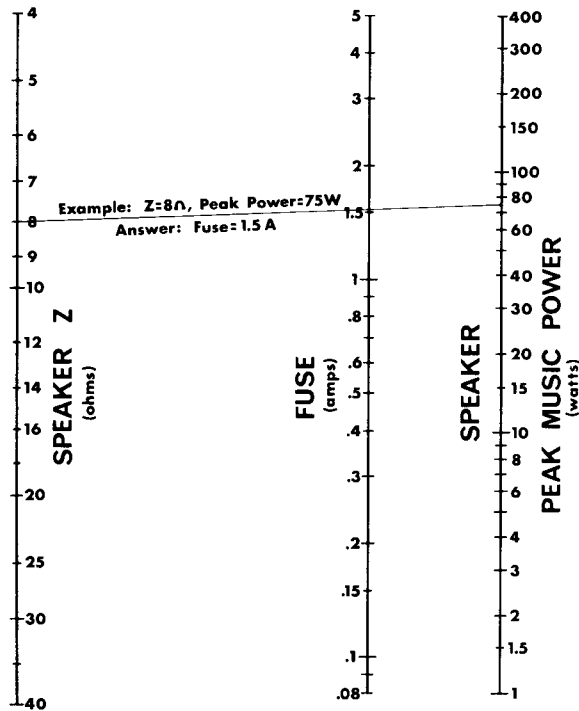

FIG. 3-3
FUSE SELECTOR NOMOGRAPH FOR
LOUDSPEAKER PROTECTION

Another form of load protector is shown schematically in Fig. 3-4. Whenever the load is overdriven, a relay switches a lamp in series with the load, smoothly relieving the overload. The lamp then doubles as an overdrive indicator as it glows. If overdrive is unreasonably severe, the lamp will serve as a fuse. By adjusting the relay tension adjustment and the protection level control, this system is useful from 25 to 200 watts for a typical 8 ohm load.

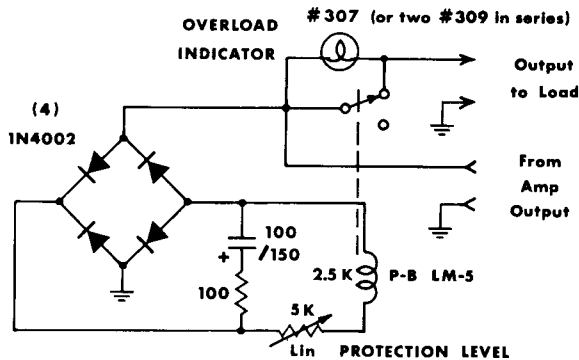

FIG. 3-4
RELAY CONTROLLED PROTECTOR
WITH OVERLOAD INDICATOR

Another more sophisticated form of overload protector relieves the overload by controlling the amplifier's input signal which is creating the overload. This form of protector not only saves the load but also eliminates amplifier overload. With this device, it is possible to operate the amplifier at its maximum level with a minimum of clipping. This device is shown schematically in Fig. 3-5. It features an overdrive indicator, distortionless photo-optical control, and a Protection Level control giving adjustment from 1W to 200W when driving 8 ohms.

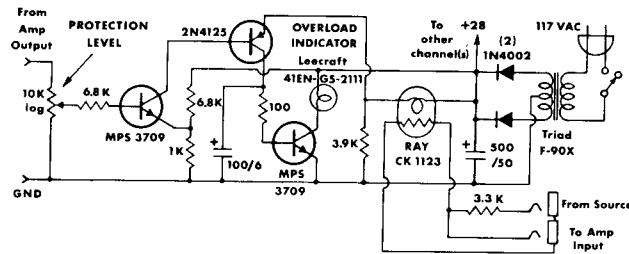

FIG. 3-5
PEAK POWER LIMITING COMPRESSOR
WITH OVERDRIVE INDICATOR

A common problem which causes damage and irritation is the turn-on thump problem typical to many signal sources. Fig. 3-6 shows the schematic of a muter which, when inserted in the input signal line, mutes for several seconds before connecting the source to the amplifier, thereby eliminating turn-on transients. It also removes turn-off transients occurring after the relay drops open (≈ 0.1 sec.).

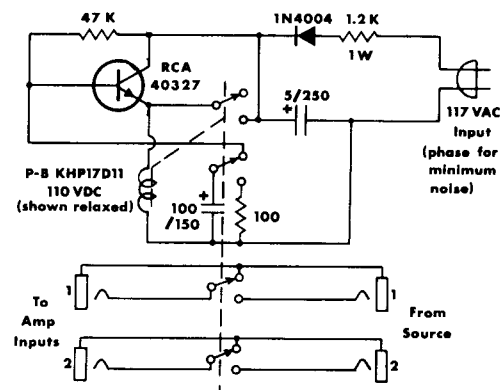

FIG. 3-6
TURN-ON-TRANSIENT MUTER FOR
LOAD PROTECTION

3.5 CLEANING

The CROWN DC-300A has a rugged anodized front panel for life-time service. The panel can be cleaned with a moist cloth and mild detergent. Never use steel wool, scouring powder, lye solution, or any strong abrasive cleaner as these will damage the panel's finish.

The back chassis should require no more cleaning than periodic dusting with a clean dry cloth. The use of detergents, abrasives or other cleaners may remove the fine film of oil from the black anodized chassis which is used to increase its surface lustre.

1. Use the *proper* line voltage, which is the one for which the amplifier is connected. The voltage should be measured throughout the testing with a peak reading meter, and adjusted to the RMS equivalent voltage (to compensate for line voltage regulation errors during the course of the measurements). All measurements should be taken at the power amplifier's plug. When testing for IHF music-power measurements, the line voltage is to be set at 120V when the amplifier is connected to 120V, (IHF standards). If the amp is connected otherwise, the equivalent test may be given by applying 128 volts on 128V, 240V on 240V, or 256V on 256V line.
2. The load should be resistive, having less than 10% reactive component at any frequency up to five times the highest test frequency. The resistor should be capable of continuously dissipating the full output of the amplifier while maintaining its resistance within 1% of its rated value. The load should employ only high-current connectors (if any), and be connected to the binding-post output terminals. All output measurements should be taken at the amplifier output terminals, and not anywhere along the output cable through which the load current is flowing.
3. The input level controls should be set to maximum for all distortion tests to assure repeatability of all measurements.
4. When measuring hum and noise, all inputs should be disconnected from the amplifier and the level controls set to minimum or to maximum, preferably minimum.
5. Whenever possible avoid ground loops in the test equipment caused by connecting the output ground to the input ground. *Never* connect the ground of the cable going to the load back to the input ground.

Ground loops are especially obnoxious when measuring distortion. An I-M distortion analyzer, for example, has its input and output terminals tied to a common ground. Such a test should use an ungrounded output return, with the output lead(s) wrapped around the well-shielded and grounded input cable.

6. Always monitor the test oscillator when measuring frequency response. Use a wide-band AC voltmeter; or use the same meter for both input and output level measurements, if the meter's frequency re-

sponse is known not to be dependent on attenuator settings.

7. Accuracy in measuring voltages for computing wattage is critical. For example, a 2% voltage error together with a 1% resistance error can result in an error of 10 watts power into 8 Ω .
8. Residual distortion and noise levels should be fully known for all the test equipment in order to accurately evaluate the amplifier.
9. Never attempt to measure damping factor by placing abnormal loads on the output. D-F measurements taken during clipping, or any other form of overload, are meaningless. The preferred method is to apply an externally generated current to the output terminals and measure the resultant voltage at the terminals. A convenient current is one ampere — as the resultant voltage will read directly in ohms for $|Z_o|$. Damping Factor is defined as $|\frac{Z_o}{Z_L}|$, where $|Z_L|$ is typically 8 ohms. A convenient generator for the 1A. current is that amplifier channel not under test. A non-inductive resistance of 8 ohms — coupled between both channels' output terminals — will provide 1A. when 8 volts are impressed across the resistor (by that channel not under test).
10. Never measure hum and noise when in the presence of strong magnetic fields. The amplifier should be at least 4 inches away from any large metallic objects or shield plates for a reading to be meaningful.
11. Noise measurements should be taken with a band-pass filter of 20-20KHz. For audio purposes the measurement of noise above 20KHz is meaningless.

4.3 SERVICE

Should service other than routine fuse replacement ever be required, it is recommended that the unit be returned to the factory in the original packing (or replacement, if damaged). For warranty service the machine must be returned to the factory or warranty service station. The CROWN warranty is detailed on page 11.

Because of the level of circuitry sophistication of the DC-300A, only the most competent technicians should be allowed to service it.

Many of the parts are standard items stocked by most supply houses. However, there are several which appear to be standard parts but are actually different. Although standard parts may be used in an emergency, best results will be with factory parts. A number of the parts are available only from CROWN.

When ordering parts, be sure to give the amplifier serial number as well as the part number and description. Rated firms will be billed, otherwise shipments will

be C.O.D.

Before returning an amplifier to the factory for service, authorization should first be obtained from the service manager. All shipments must be sent by Railway Express or truck freight, prepaid and insured at total value. The factory will return your serviced unit by Railway Express or truck freight, collect, and will add C.O.D. charges in the event that the cost is not covered by registered warranty.

APPLICATION NOTES

Evaluating the V-I (volt-ampere) needs of a load: Many loads exhibit large reactances (or energy storage), which limits a power amplifier's ability to deliver a maximum power. If a load stores energy, which in turn flows back into the amplifier, it is clear that the maximum power efficiency of the system is not being achieved. Power that flows back into a linear amplifier must necessarily be dissipated in the form of heat. A pure reactance is not capable of dissipating any power; therefore to drive such a load would only cause power amplifier heating.

In practice all loads exhibit some energy dissipation — however large their energy storage characteristics may be. The ideal coupling to any load is one that optimizes the desired dissipation component while minimizing the reactive or stored-energy component that is seen by the amplifier's output terminals.

In applications where the input is sinusoidal and of small proportional frequency deviation, a relatively stable load may be resonantly tuned to present a real value of impedance to the amplifier.

Any load, no matter how complex its behavior, has a V-I operating range which may be mapped by the following test.

The maximum voltage and amperage excursions in all directions about zero (center of scope screen) define the volt-ampere operating range of the load. If a load is known to be linear over its operating range it is not necessary to supply the maximum desired power to the load. The test may be conducted at low signal levels and the current-sensing resistor (indicated as 0.1Ω) may be enlarged to a convenient value for the oscilloscope's deflection sensitivity. The resulting plot may be then linearly scaled to the desired operating level.

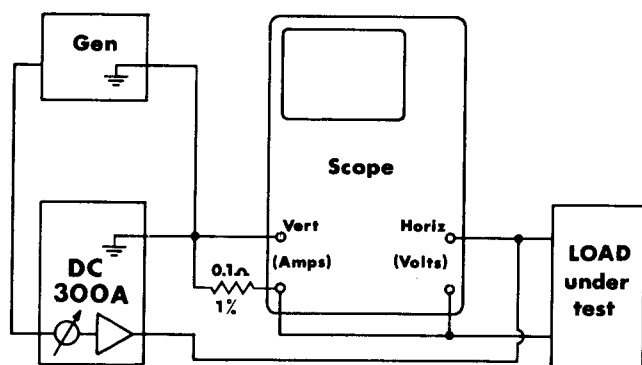

Note: Scope and amplifier grounds are not common. Vertical input reads (-) amperes vertically. If scope has an inverter, invert to read (+) A.

AMPLIFIER LIMITS OF VI OUTPUT

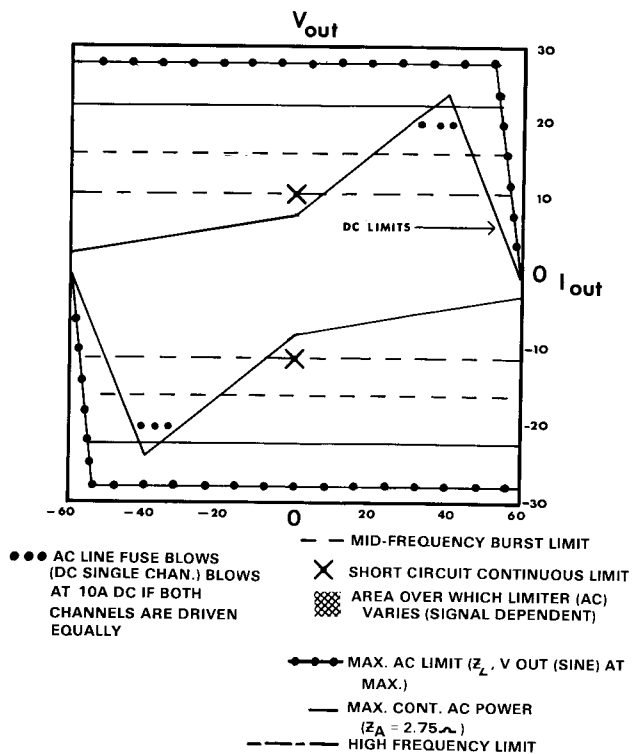

DC-300A MONO CONVERSION

APPLICATION NOTE NO. 2

A. Access to circuit board

1. Remove screws (4 top and 4 bottom) mounting top and bottom covers to front panel.
2. Remove mounting screws (2 each end) connecting front panel to heat sinks.
3. If front panel will move more freely, proceed to step 4. If front panel is still contacting the heat sinks at both ends, loosen screws in top and bottom covers to free front panel.
4. Carefully lift the front panel straight out from between the heat sinks, being careful not to tilt the panel in any direction until it is free of the amp, and also being careful not to scratch the interior surface of the rack mounting bars with the front panel ends.
5. Set the panel down carefully to avoid scratching it or straining the level control cables by which it remains attached to the amplifier.

B. Wiring changes

1. On the exposed circuit board, locate printed circuit sockets A, B, C, and D (Fig. 1), being careful to distinguish them from other sockets on the board.
2. Mount a 2¼" length of insulated hookup wire (¼" of insulation stripped from each end) by inserting the ends into sockets A and B. (This operation grounds the channel 2 input.)
3. Mount a 10K , 1% tolerance, ½ watt resistor with insulated leads by inserting the lead ends into sockets C and D. (This feeds the channel 1 output signal into the channel 2 inverting input.)

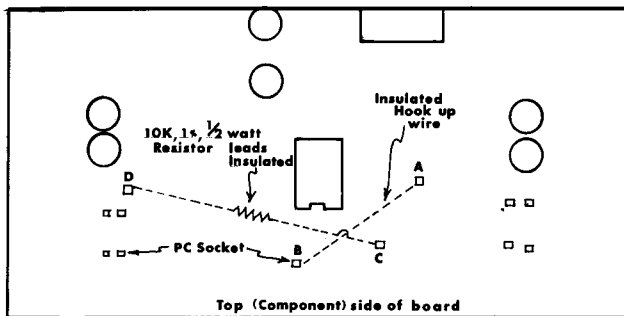

Fig. 1

C. Reassembly: reverse the procedure of step A.

D. Operation

1. Make output cable as shown in Fig. 2.
2. Connect one lead to HOT (red) amplifier output post of channel 1, the other lead to HOT output post of channel 2.

CAUTION: DO NOT CONNECT EITHER HOT OUTPUT TO GROUND (EITHER BLACK POST).

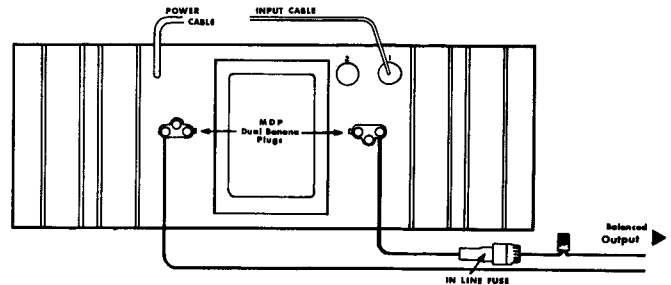

Fig. 2

3. Connect any desired load to the output cable. A fuse is recommended! (CROWN speakers excepted.) (Refer to Fig. 2-2 on page 13 of the DC-300A manual.)
4. Connect input signal, using standard ¼" phone plug, to the channel 1 input jack. The channel 1 level control will adjust the gain. (The channel 2 input and level control are bypassed and in-operative in this mode.)
5. The 3-wire AC power cord meets U/L requirements. Many installations will require a 3-to-2 wire adapter to avoid ground loops, or multiple ground paths which may allow circulating ground currents.

E. Performance Specifications

See Page 2A

APPLICATION NOTE NO. 3

VFX-2

The CROWN VFX-2 is a dual-channel variable electronic filter-crossover. When used with a power amplifier it can greatly add to the total system capability. In combination with the DC-300A, the VFX-2 adds several convenient useful functions.

First, the DC-300A can be used as a mono amplifier without internal modifications. The connections are made with the VFX-2 quickly and easily. If a balanced line is to be used with the unbalanced input of the DC-300A, the VFX-2 can serve as the interface. While maintaining these functions the output can be shaped by selecting variable high-pass,

lo-pass, or band-pass filters. As a filter, the VFX-2 can be used as a crossover or ahead of several amplifiers in a bi- or tri-amped system.

Overall noise and distortion are extremely low, with IM distortion less than .01% at rated output (2.5V into 600 ohms), and noise more than 100dB below rated output with 0dB gain.

For further information please request the VFX-2 specification sheet or for a nominal fee, purchase a VFX-2 instruction manual.



VFX-2

APPLICATION NOTE NO. 4

WARNING

POWER AMPLIFIER PROTECTION SYSTEMS PROTECT AMPLIFIERS BUT NOT SPEAKERS! YOU, AND/OR YOUR SPEAKER MANUFACTURER ARE RESPONSIBLE FOR SPEAKER PROTECTION!

Except in unusual sets of circumstances, the circuitry included in power amplifiers designated as "protection", whether made up of transistor limiters, circuit breakers, fuses, SCR's, or whatever, is designed primarily to protect the amplifier from damage and will only protect speakers incidentally. There are some exceptions to this rule, which allow the user to vary the output power limits of his amplifier to match the power rating of his speakers. Even this, however, is a far from perfect speaker protection scheme. The reason why this holds true is simple: each make or model speaker has its own unique operating capabilities. As a rule, a speaker system (including all electronics parts such as crossover parts and electrostatic element transformers, as well as voice coils) will be able to dissipate a certain amount of power continuously without burning up. This depends on the size, quality, configuration, etc., of those parts. The same speaker will be able to handle a somewhat higher power level for a short period of time (in the millisecond range) without being destroyed by heat, but may then be endangered by such phenomena as extending moving elements beyond their normal range of travel (bottoming, torn diaphragm, etc.), overvoltageing electrostatic panels (arcing), or other such suddenly disabling events. Since the points at which these disastrous happenings will occur, differ for different speakers, a speaker protection system must be completely adjustable if it is to be useful for more than a narrow range of speakers. Furthermore, if the user is to be able to do adequate adjustment on a protection system external to his speakers, he must receive accurate information about the speaker power handling capabilities from the speaker manufacturer. Speaker protection systems embodied in amplifiers are comparatively useless, therefore, unless the following things are true:

- (1) The protection system can be accurately adjusted by the user.
- (2) The power handling capabilities of the speakers are clearly stated by the manufacturer.
- (3) The information about the speaker protection and speaker power handling are stated in common terms so that the user can adjust the protection properly for the speaker.

These three things are rarely true simultaneously. It is for this reason that CROWN takes the approach that speaker protection is the responsibility of the speaker manufacturer. Amplifier manufacturers have long been required to provide protection in their products for any faults occurring externally to the amplifier outputs, such as speaker short circuits, open circuits, etc. In order to

fairly share the responsibility, and since the protection cannot be exhaustively provided any other way, we feel that speaker manufacturers should provide protection tailored to their individual products. At CROWN we have done this with our own speakers, simply because it is the only comprehensive means of providing worthwhile protection for all of our speakers.

Increasing power available from modern amplifiers increases the danger of speaker damage. Although occasionally an internal amplifier malfunction can contribute to speaker failure, it is much more likely that speakers will be overpowered by inadvertent use of too much power. In the absence of internal protection in most speaker systems, CROWN recommends very strongly that in-line speaker fuses be employed in all systems. The fuse selection nomograph reprinted in each CROWN amplifier manual can be an invaluable help in choosing fuses of the proper size. However, the effectiveness of fuses in protecting speakers is limited in two important ways:

- (1) Fuses as a rule protect only against prolonged overpowering, and can only prevent speakers from being driven with more than their RMS or average power rating. Fuses cannot protect against sudden high level transients of short duration. The use of high-speed instrument fuses will give the best protection available from fuses, but musical transients can have an effect before the fastest fuses blow.
- (2) An appropriate fuse can only be selected if the manufacturer's specifications for his speaker are accurately and clearly stated. If a speaker can handle 100 watt peaks and 30 watts continuously, but is advertised, and therefore fused, as a 100 watt speaker, then the speaker will destroy itself before the fuse can protect it under a continuous power level above 30 watts.

There are more effective (also more complicated and expensive) methods of protecting speakers than fuses. Some of these, including methods similar to those employed in CROWN speakers, are illustrated in the load protection section of CROWN amplifier manuals. But these systems, as all others, must still be adjusted in accordance with the power-handling capability of the speakers in use, and this can still be most readily done by speaker manufacturers.

Your speakers have probably cost you at least as much as any other part of your audio system. And since speaker sound continues to be the most subjective area of component selection, you may also have devoted more time and effort to selecting your speakers than you have devoted to any other part of your system. With these facts in mind, be extremely careful in providing for adequate protection of these often fragile, but most important, expressions of your audio taste.



crown

DC-300A
IM-9
S3P2-15-6

INSTRUCTION MANUAL

SERIAL NO _____
ISSUED _____

DC-300A
DUAL CHANNEL
LABORATORY AMPLIFIER



BATCH I D

SERIAL NO

DCA-11

020163

Proof of Performance Report

DC-300A laboratory power amplifier

Serial Number 20163

Line Voltage Requirement 120 VAC

Board Number 48723

Amcron Label _____

Technician Guy Braden

	CH.1	CH.2	
1. Quies. offset of less than 10mV	<u>✓</u>	<u>✓</u>	
2. 1 KHz 180 watts RMS minimum into 8 ohms, per channel, both channels operating, 0.1% total harmonic distortion	<u>✓</u>	<u>✓</u>	
3. 4 ohm test	<u>✓</u>	<u>✓</u>	
4. Protection tests	<u>✓</u>	<u>✓</u>	
5. Reliability test	<u>✓</u>	<u>✓</u>	
6. 20KHz 155 watts per channel minimum RMS (both channels operating) into 8 ohm. 0.05% total harmonic distortion	<u>✓</u>	<u>✓</u>	
7. 10 KHz. sq. wave	<u>✓</u>	<u>✓</u>	
8. Mono operation	<u>✓</u>	<u>✓</u>	
9. IM Dist. into 8 ohms (%) (60-7KHz 4:1) S.M.P.T.E.	<u>.002</u> <u>-.002</u> <u>-.002</u> <u>-.002</u> <u>-.003</u> <u>-.004</u> <u>-.006</u> <u>-.008</u> <u>-.014</u>	155W 49.0W 15.5w 4.9w 1.55w 490mW 155mW 49 m W 15.5mW	<u>-.003</u> <u>-.002</u> <u>-.002</u> <u>-.002</u> <u>-.003</u> <u>-.004</u> <u>-.005</u> <u>-.009</u> <u>-.014</u>
10. Hum and noise-db below 155W into 8 ohm (20Hz - 20KHz)	<u>121</u> db	<u>121</u> db	
11. Quies. AC power input at 120 VAC is	<u>40</u> W		

' TOTAL PERFORMANCE IS WHAT COUNTS'

CROWN test and check-out procedures reflect our basic design philosophy; we believe that reliability can be engineered into a product. As such, our check-out is designed to expose and correct a problem, before it happens. This testing begins when the unit is still a pile of parts; grading and selection of components is standard. The final test-inspection is the culmination of this vigorous program, but our concern doesn't stop here. Our products are backed by an extensive field service program, and protected by a comprehensive warranty.

A word about our testing procedure is in order. All our specifications are referenced to an AC input of 120 VAC. The high current demand with high power tends to cause the line voltage to sag, or the sinusoidal waveform to distort. With a distorted waveform (or lower line voltage) the peak voltage is lowered. Since it is the peaks that charge the filter capacitors in the amplifier power supply, and thus determine the maximum power output, a line voltage problem reduces the maximum power output. CROWN uses a peak equivalent AC voltmeter which measures the peaks of any waveform and converts this to an equivalent rms reading for a sinusoidal waveform. This way we can vary or regulate the line voltage, no matter how distorted the waveform, to an equivalent of a 120 VAC sine wave. We are then measuring a true maximum output power.

With regard to the precision load which we use for our testing, we realize that a resistive load is quite different than a reactive speaker. However, using readily available parts, a precision resistive load is the easiest to duplicate, with respect to obtaining consistent results. We specify that the load must be resistive, having less than 10% reactive component at any frequency up to five times the highest test frequency. The resistance value should be maintained within 1%, at all power levels.

The following discussion examines each of the test procedures listed on the facing page. This is an attempt to help you understand, in layman's terms, what the tests mean.

1. Quiescent Offset - This simply assures that your amplifier's output is balanced with reference to its input. Thus the amplifier will not "bias" the program with a dc component. To meet specifications, offset must be less than 10 mv.
2. 1KHz - This test measures the power across an 8 ohm load at a **frequency** of 1 KHz with both channels operating. This is a determination of how much power an amplifier can produce before a specified total harmonic distortion is reached. For the DC-300A, the power is 180 watts at less than .1% THD.
3. 4 Ohm Test - This is a critical examination of the DC-300's performance at impedances below that for which it is rated. We check the wave form for level (it must reach a specified voltage before clipping) purity, and stability.
4. Protection Test - This is a test with a 2 ohm load which determines the threshold at which the protection circuitry will be activated. Sharp clipping should occur with no evidence of instability. The positive and negative limiters operated independently and therefore may not be activated simultaneously.
5. Reliability Test - This test puts the output stages through an extremely vigorous thermal cycling. The test is a very low frequency input signal driving the output to full power across a short circuit for a predetermined period of time.
6. 20KHz - This tests the amplifier at its rated power level. We specify that at any frequency between 1Hz and 20KHz the DC-300A will produce 155 watts minimum rms (both channels operating) into an 8 ohm load, at a sum total harmonic distortion of .05% or less. We choose 20KHz as the test frequency because high frequencies produce more heat than lower frequencies. Thus, if the amplifier can safely pass the 20KHz test, it will operate safely at lower frequencies.
7. 10 KHz Square Wave - This test critically examines the amplifier's frequency response and rise time. (How fast the amplifier can follow rapid signal changes.) The output square wave (with an 8 ohm load) should be clean and sharp, with no ringing or overshoot.
8. Mono Operation - This is a check for proper operation of the stereo mono switch. A signal is applied to channel 1 input only and the mono output is observed between the two red output terminals of the amplifier.
9. IM Distortion Test - At CROWN we feel that IM distortion testing yields a truer picture of amplifier performance than harmonic distortion testing. While a large amount of documentation supports this opinion, some of the reasons are apparent, even in layman's terms. For example, a sinusoidal waveform (used in HD testing) bears little resemblance to the complex waveforms associated with actual program materials. IMD testing uses such a complex waveform. Also, harmonic distortion is not always aurally offensive. The human ear may interpret such distortion as pleasing, but usually finds IM distortion rather obnoxious. In order to support this design philosophy, we designed and built our own IM analyzer with residual noise and distortion low enough to test our amplifiers.
10. Hum and Noise - This test, in plain English, tells you how small a signal can be amplified without it becoming "lost in the mud". The test is limited to the audio band width of 20Hz-20KHz, with a bandpass filter. Our specification for the DC-300A is: hum and noise from 20Hz -20KHz will be at least 110db below the full power output of 155 watts. This means that with a 155 watt output the noise will be only .00155 micro watts. (That's 1.55 billionths of a watt)
11. Quiescent AC power Input at 120 VAC - This test confirms that your amplifier is not drawing excessive power while "idling". If an amplifier exhibits a tendency toward instability, or oscillation, it may draw power with no signal input. The DC-300A will draw 40 watts or less at idle.

TABLE OF CONTENTS

	PAGE
Section 1 DESCRIPTION	
1.1 General	1
1.2 Specifications	2, 3, 4, 5
1.3 Warranty	12
Section 2 INSTALLATION	
2.1 Unpacking	13
2.2 Mounting	13
2.3 Normal Hi-Fi Installation	13
2.4 Connecting Output Lines	14
2.4.1 Mono Operation	16
2.5 Connecting Input Lines	16
2.6 Connecting Power	17
Section 3 OPERATING INSTRUCTIONS	
3.1 Controls and Adjustments	19
3.2 The Protection Mechanisms	19
3.3 Operating Precautions	21
3.4 Load Protection Methods	21
3.5 Cleaning	22
Section 4 CIRCUITRY	
4.1 Principles of Operation	23
4.2 Test Procedures	24
4.3 Service	24
Section 5 APPLICATION NOTES	
Application Note No. 1 — V-I Limits of a Load	25
Application Note No. 2 — VFX-2	27
Application Note No. 3 — Speaker Protection	29

LIST OF ILLUSTRATIONS

TITLE	PAGE
I-1 DC-300A Pictorial	1
I-2 DC-300A Performance Graphs	
I.M. Distortion	5
Harmonic Distortion	5
Frequency Response	6
Power Response	6
Phase Response	7
Noise Spectrum	8
Crosstalk	8
Nominal Limits of V-I Output	9
Damping Factor	10
Power Efficiency	10
Input Impedance vs. Gain	11

	Maximum Output vs. Load Impedance	11
	output (Z)	12
	output $\left \frac{Z}{Z} \right $	12
2-1	Mounting Dimensions	13
2-2	Normal Hi-Fi Hook-up	14
2-3	Rear View of Chassis	14
2-4	Source Resistance and Damping Factor vs. Length and Size of Output Leads	15
2-5	Schematic For Full Range Electrostatic Speaker Connections	15
2-6	Schematic of Earphone Pad	16
2-7	DC-30DA Mono Hook-up	16
2-8	Table For Selection of Input DC Blocking Capacitor	17
2-9	Low-Pass Filter For Severe RF At Inputs	17
2-10	Table of Line Voltage Connections	18
3-1	Operating Controls	19
3-2	Graph of VI Operating Range of DC-300A Output	20
3-3	Fuse Selector Nomograph For Loudspeaker Protection	22
3-4	Relay Controlled Protector with Overload Indicator	22
3-5	Turn-On-Transient Muter For Load Protection	22

DESCRIPTION

1.1 GENERAL



FIG. 1 - 1
DC-300A PICTORIAL

The DC-300A is a dual-channel high-power amplifier for precision amplification of frequencies from DC to 20KHz. The unit features extremely low harmonic and intermodulation distortion, very low noise, highest "damping factor," and quality parts and workmanship. Because of the large output power, it is possible to obtain a monaural 70-volt balanced line without using an output transformer.

The DC-300A contains a new CROWN developed Signal Programmed Automatic Current Executor (SPACE control) electronic amplifier protection circuit which manifests no flyback pulses, thumps, or shut-down. At audio frequencies any impedance load including totally reactive loads may be driven with no adverse effects. Only maximum output power will be affected by variations in load impedance. At sub-sonic to DC frequencies the limiter acts as a VI limiter to provide optimum protection for the extremely rugged silicon homotaxial output devices (total of 16 for a total of 2400W dissipation).

A pair of thermal switches remove power from the unit if overheating occurs due to insufficient ventilation. The AC line is fused to protect the power supply.

See Section 3.2 for a description of the protective systems.

The power supply features a 1 KW transformer and large computer-grade filter capacitors giving over 48 joules of energy storage.

A total of 44 discrete transistors, 1 linear IC (dual op amp),

26 diodes, 1 bridge rectifier, and 3 zener diodes are used in the DC-300A circuitry. With the integrated circuit, the effective number of semiconductors is 60 transistors, 30 diodes, and 3 zener diodes.

The output devices, 8/channel, are conservatively employed, having a total peak current rating/channel of 120 amps in a circuit that is limited to a maximum of 28 amps. Among its unique features, the circuitry includes the CROWN-pioneered and patented AB+B output configuration.

The input operational amplifiers are powered by two voltage-regulated supplies. This results in complete channel-to-channel isolation and independence from line voltage variations.

Total direct coupling results in perfect, instantaneous, thump-free overload recovery even on non-symmetrical waveforms. This cannot be said for any AC-coupled amplifier presently in existence. Turn-on is instantaneous with no program delays.

Front-panel controls include two independent heavy-duty level controls and a power switch with an associated pilot light. DC balance controls, which never need adjustment in normal operation, are located behind the front-panel.

1.2 SPECIFICATIONS

1.2.1 STEREO SPECIFICATIONS

Output Power 155 watts per channel minimum RMS (both channels operating) into an 8 ohm load over a bandwidth of 1 Hz-20KHz at a rated RMS sum total harmonic distortion of 0.05% of the fundamental output voltage.

Frequency Response	± 0.1 dB DC-20KHz at 1 watt into 8 ohms; ± 1 dB DC-100KHz.
1 KHz Power	180 watts RMS into 8 ohms, per channel, both channels operating, 0.1% total harmonic distortion.
Harmonic Distortion	Less than 0.001% from 20Hz-400Hz. and increasing linearly to 0.05% at 20KHz at 155watts RMS per channel into 8 ohms.
I.M. Distortion (60Hz-7KHz 4:1)	Less than 0.05% from 0.01 watts to 0.25 watts and less than 0.01% from 0.25 watts to 155watts into 8 ohms, per channel.
Slewing Rate	8 volts per microsecond (slewing rate is the maximum value of the first derivative of the output signal, or the maximum slope of the output signal).
Damping Factor	Greater than 750, DC-400Hz into 8 ohms.
Output Impedance	Less than 7 milliohms in series with less than 3 microhenries.
Load Impedance	Rated for 8 ohm usage; safely drives any load including completely reactive loads.
Voltage Gain	20.6 \pm 2% or 26.3 \pm 0.2dB at maximum gain.
Input Sensitivity	1.75 volts \pm 2% for 155 watts into 8 ohms.
Output Signal	Unbalanced, dual channel.

1.2.2 MONAURAL SPECIFICATIONS

Output Power 310 watts minimum RMS into a 16 ohm load over a bandwidth of 1 Hz-20KHz at a rated RMS sum total harmonic distortion of 0.05% of the fundamental output voltage.

Frequency Response	± 0.15 dB, DC-20KHz at 1 watt into 16 ohms; ± 1 dB, DC-60KHz at 1 watt into 16 ohms.
1 KHz Power	360 watts RMS into 16 ohms.
Harmonic Distortion	Less than 0.001% from 20Hz-400Hz and increasing linearly to 0.05% at 20KHz at 310 watts into 16 ohms.
I.M. Distortion	Less than 0.05% from 0.01 watts to 0.25 watts and less than 0.01% from 0.25 watts to 310 watts into 16 ohms.
Slewing Rate	16 volts per microsecond.
Damping Factor	Greater than 700, DC-400Hz into 16 ohms.
Output impedance	Less than 15 milliohms in series with less than 6 microhenries.
Load Impedance	Rated for 16 ohm usage; safely, drives any load including completely reactive loads.
Voltage Gain	$41.2 \pm 2\%$ or 32.3 ± 0.2 dB at maximum gain.
Input Sensitivity	1.75 volts for 310 watts into 16 ohms.
Output Signal	Balanced, single channel.

1.2.3 GENERAL SPECIFICATIONS

Hum and Noise (20Hz-20KHz)	110dB below rated output
Phase Response	+0, -15° Zero to 20KHz at 1 watt
Input Impedance	100K ohms at minimum gain, 10K ohms at maximum gain.
Amplifier Output Protection	Short, mismatch, and open circuit proof. Limiting is instantaneous with no flyback pulses, thumps, cutout, etc. No premature limiting on transients.
Overall Protection	AC line fused. Thermal switch in AC line protects against overheating caused by insufficient ventilation. Controlled slewing rate voltage amplifiers protect overall amplifier against RF burn-outs. Input overload protection is furnished by internal resistance at inputs of amp.
Turn-on	instantaneous, with minimum thumps and no program delay.
Circuit	Wideband multiple feedback loop design utilizing one linear IC (dual op-amp). Total equivalent of 60 transistors, 30 signal diodes, 3 zeners and 6 rectifier diodes.
Power Supply	1 kilowatt transformer with massive computer-grade filter capacitors storing over 48 joules of energy. Two regulated supplies for complete isolation and stability.
Power Requirements	Requires 50-400Hz AC with selectable taps for 100, 120, 200, 220 and 240V $\pm 10\%$ operation. Draws 40 watts or less on idle, 500 watts at 300 watts total output.
Heat Sinking	Massive black-anodized heat sinks are thermally joined with the chassis, thereby utilizing the entire amplifier as a heat sink.
Chassis	All aluminum construction for maximum heat conduction and minimum weight. Heavy aluminum front panel is a single extrusion.
Controls	Independent input level controls are on front panel. Power switch, with integral pilot light is on front panel. Non-interacting DC balance controls are mounted behind front panel. A mono-stereo switch is located above the input jacks on the rear panel.
Connectors	Input — ¼ inch phone jack Output — Color coded binding posts AC Line — Three-wire (grounded) male connector on 5 ft. min. cable
Dimensions	19 inch standard rack mount (W.E. hole spacing), 7 inches high, 9 ¾ inches deep (from mounting surface).
Weight	45 pounds
Finish	Satinized aluminum front panel, with gray suede Lexan insert.

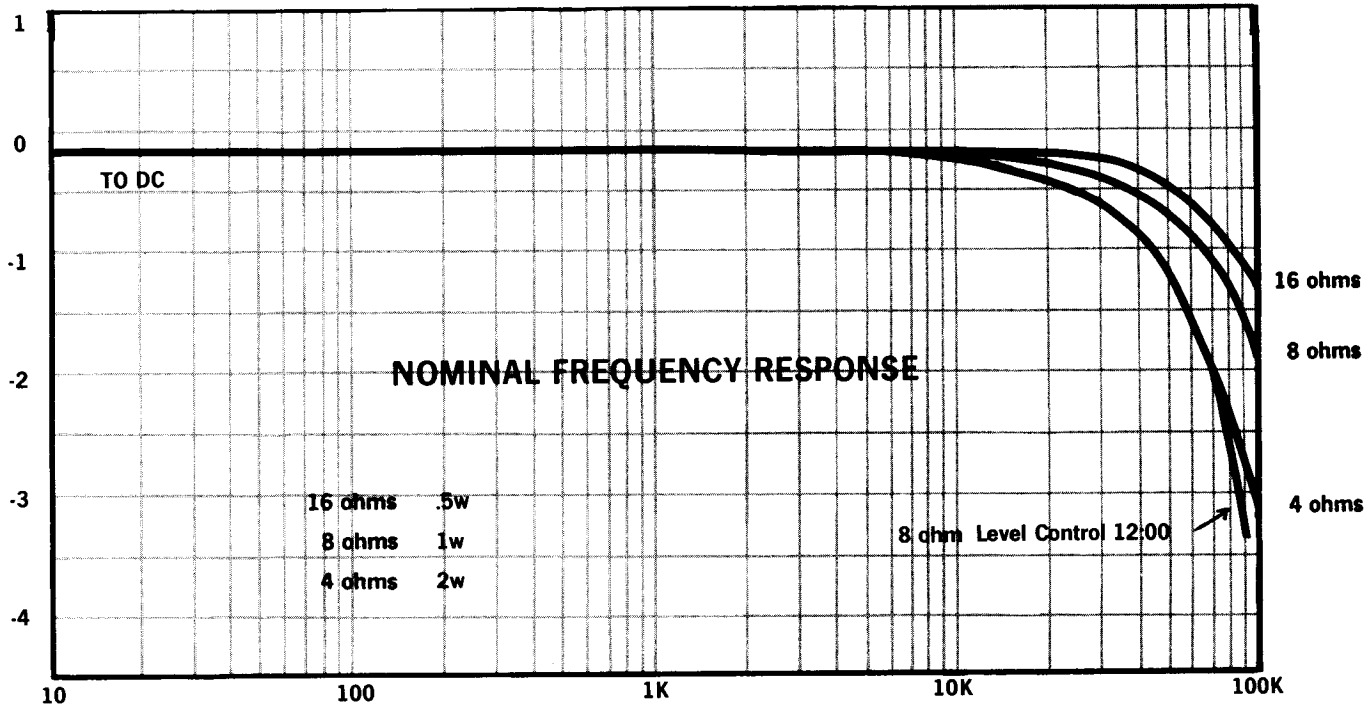

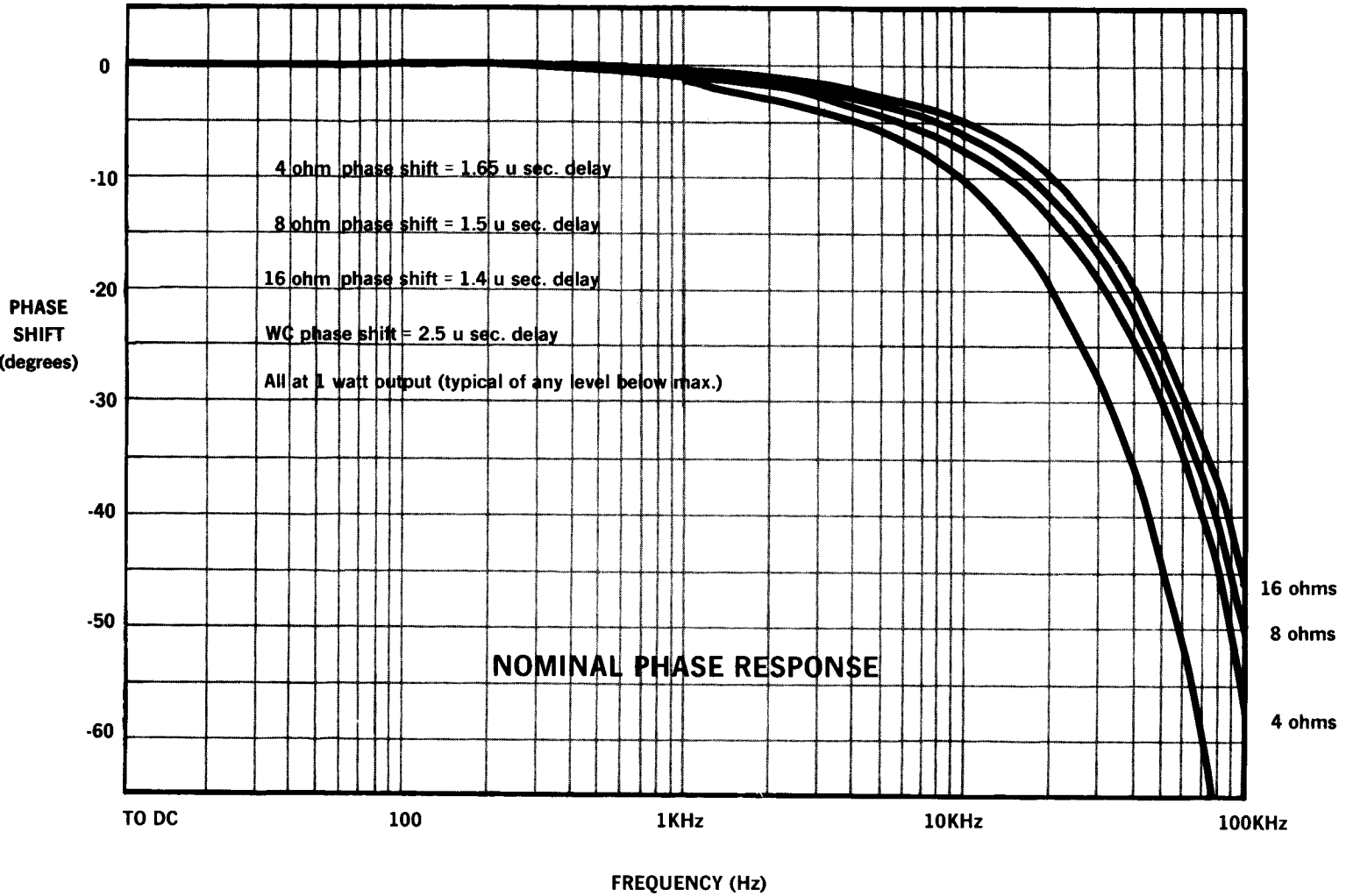

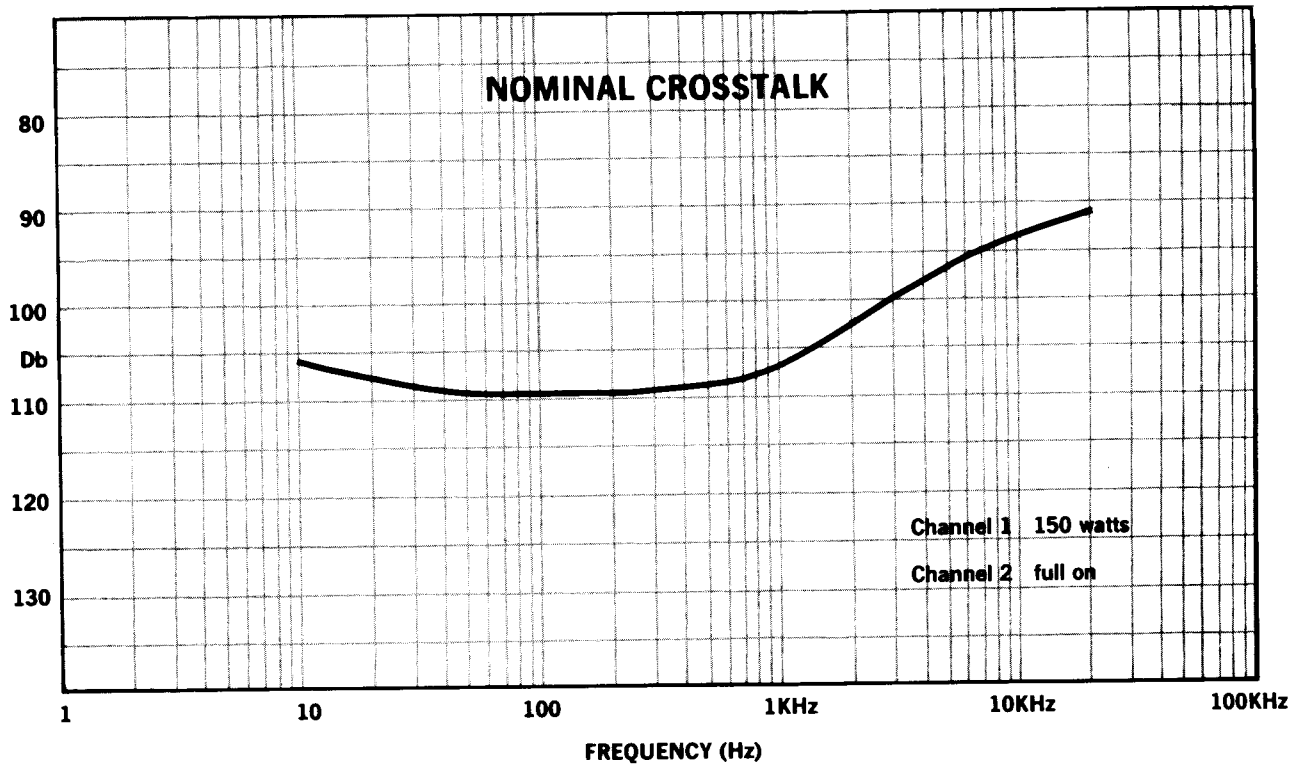
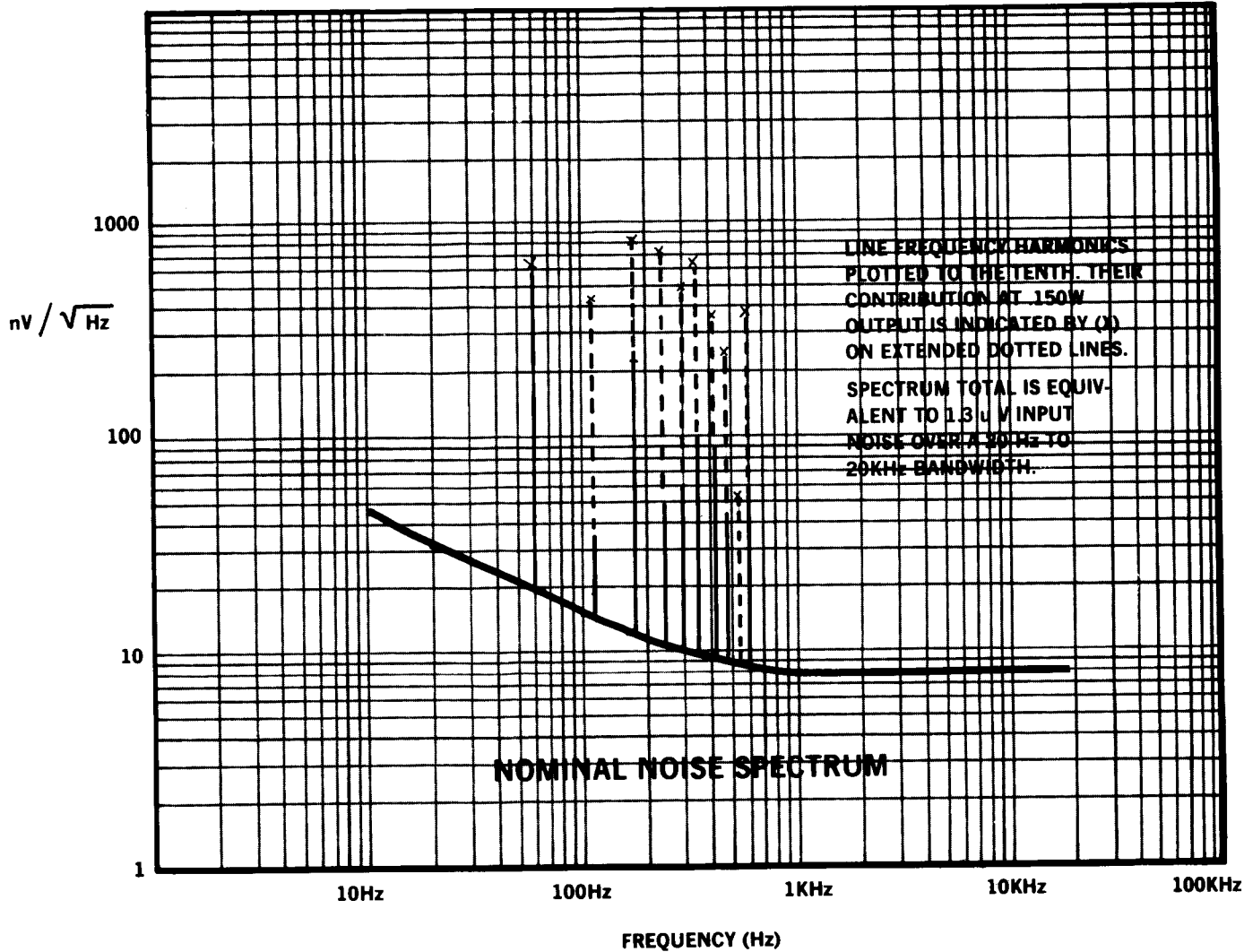

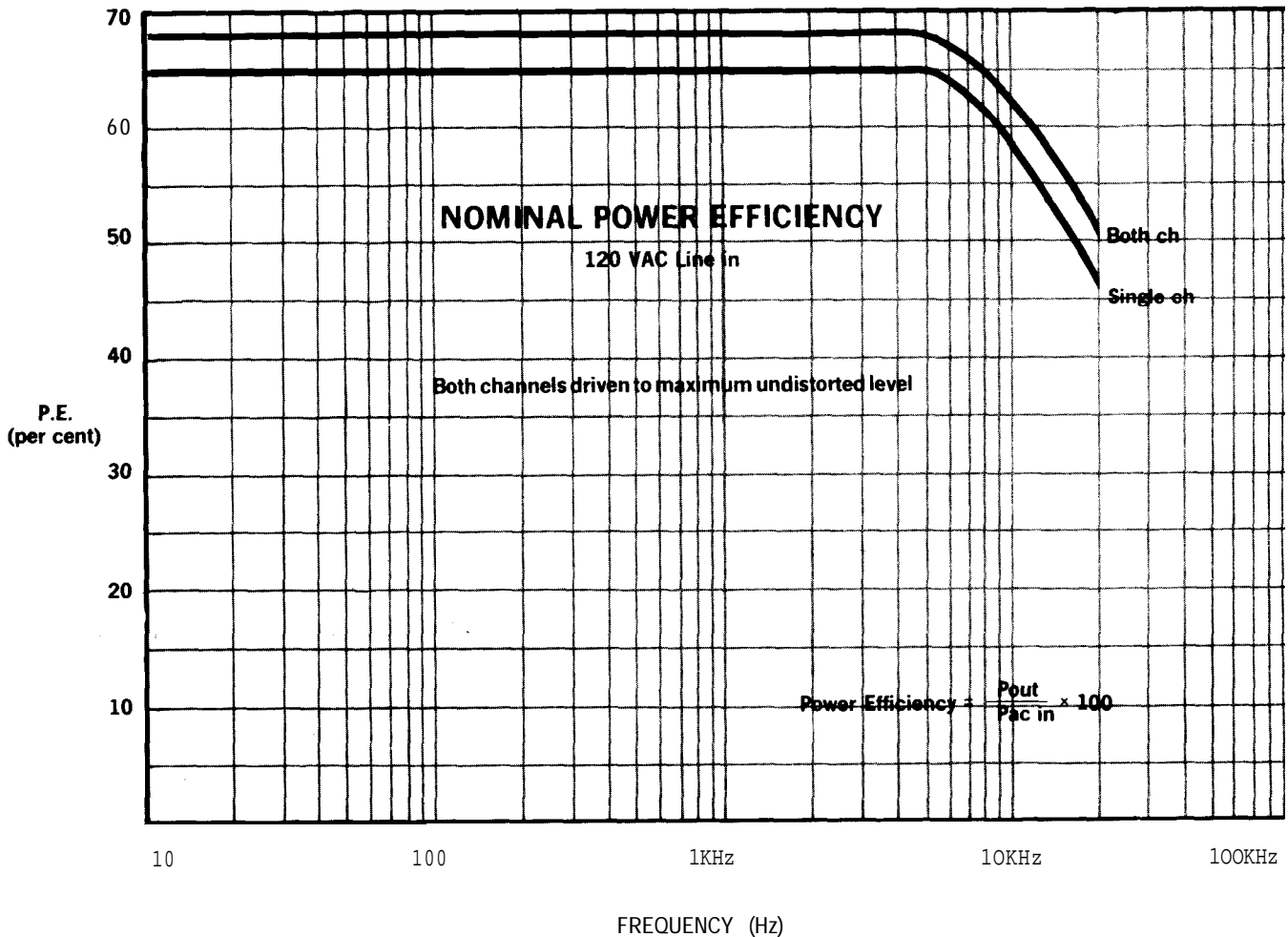
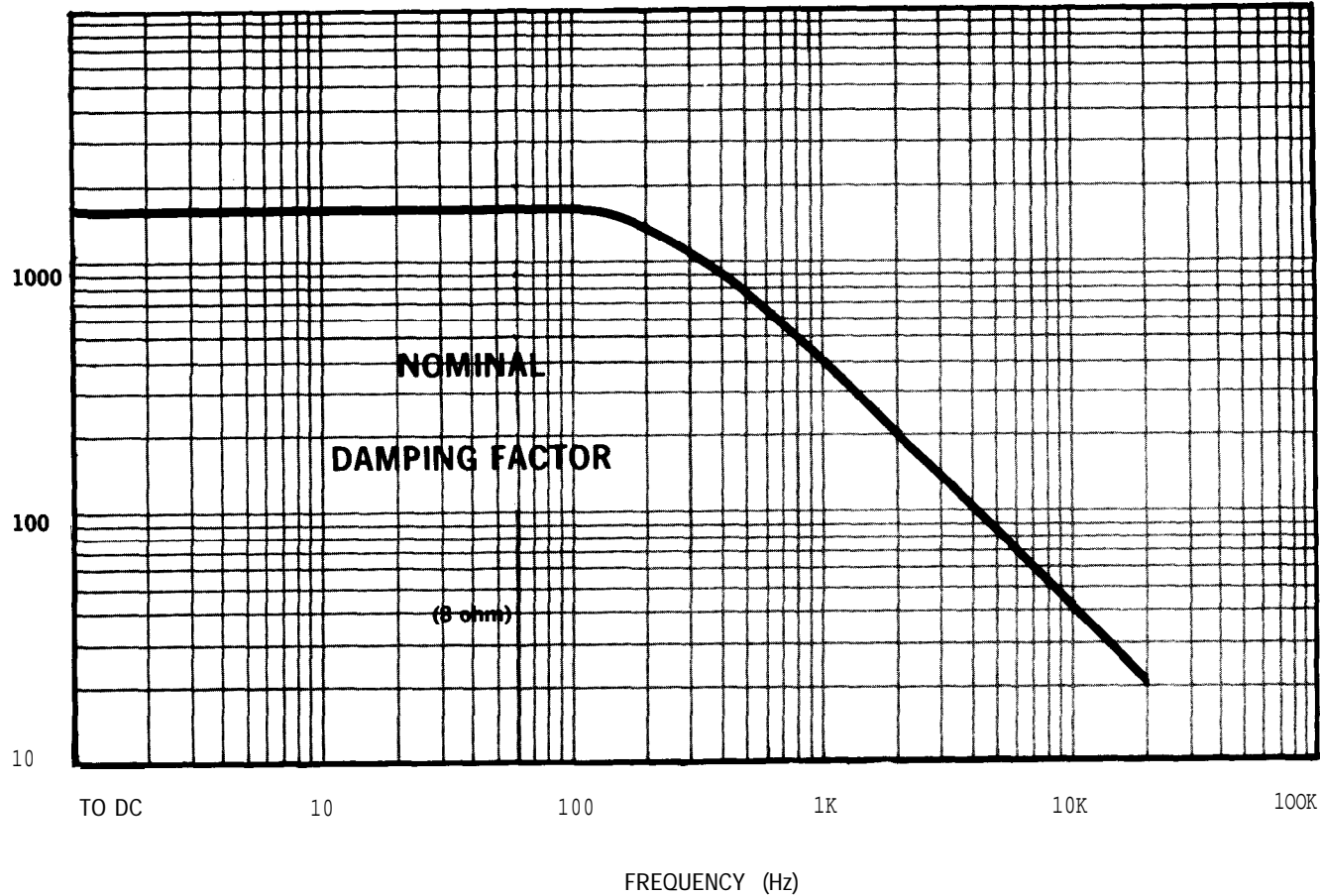

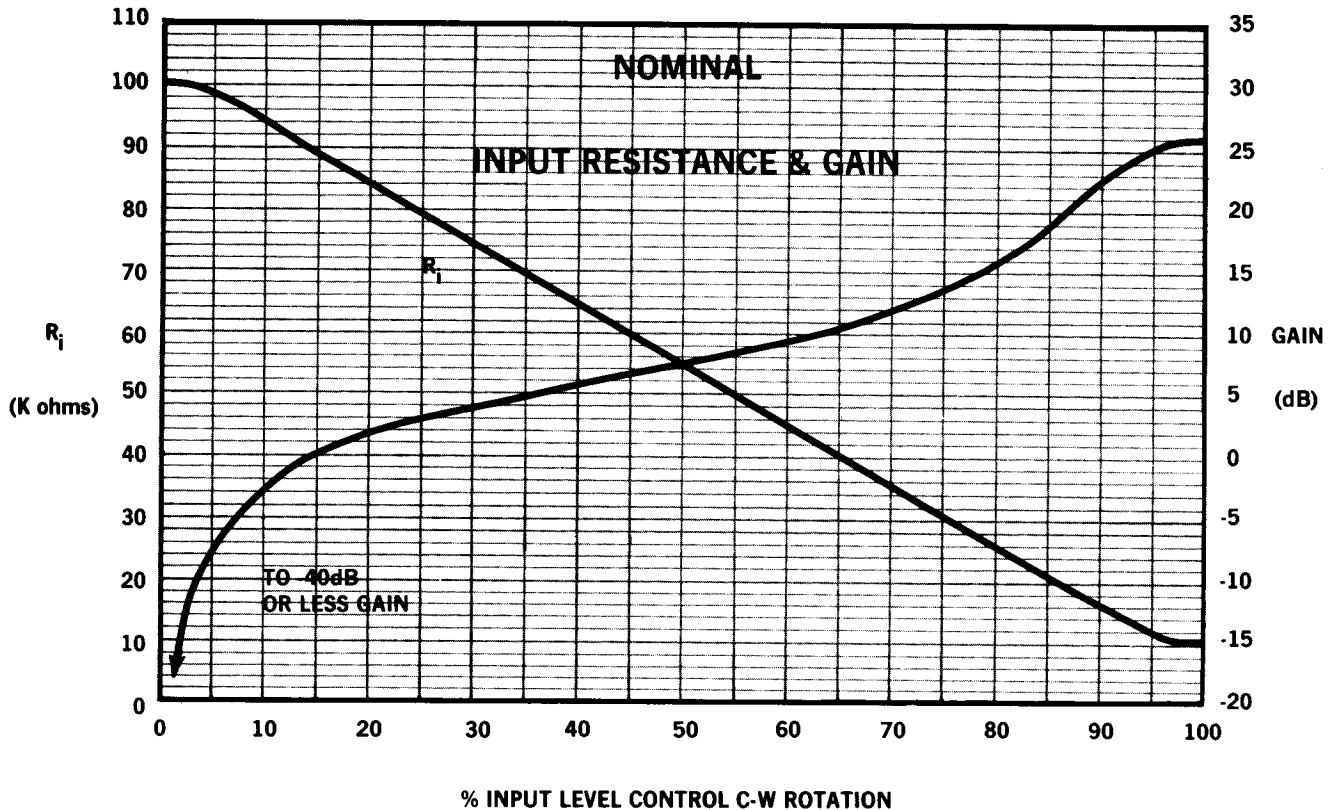

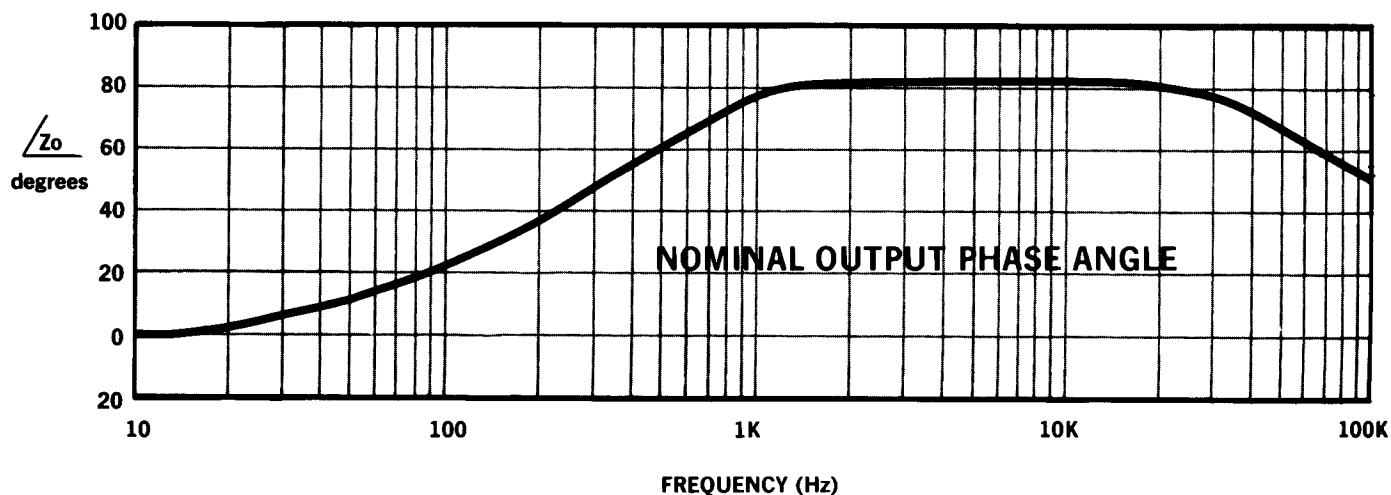
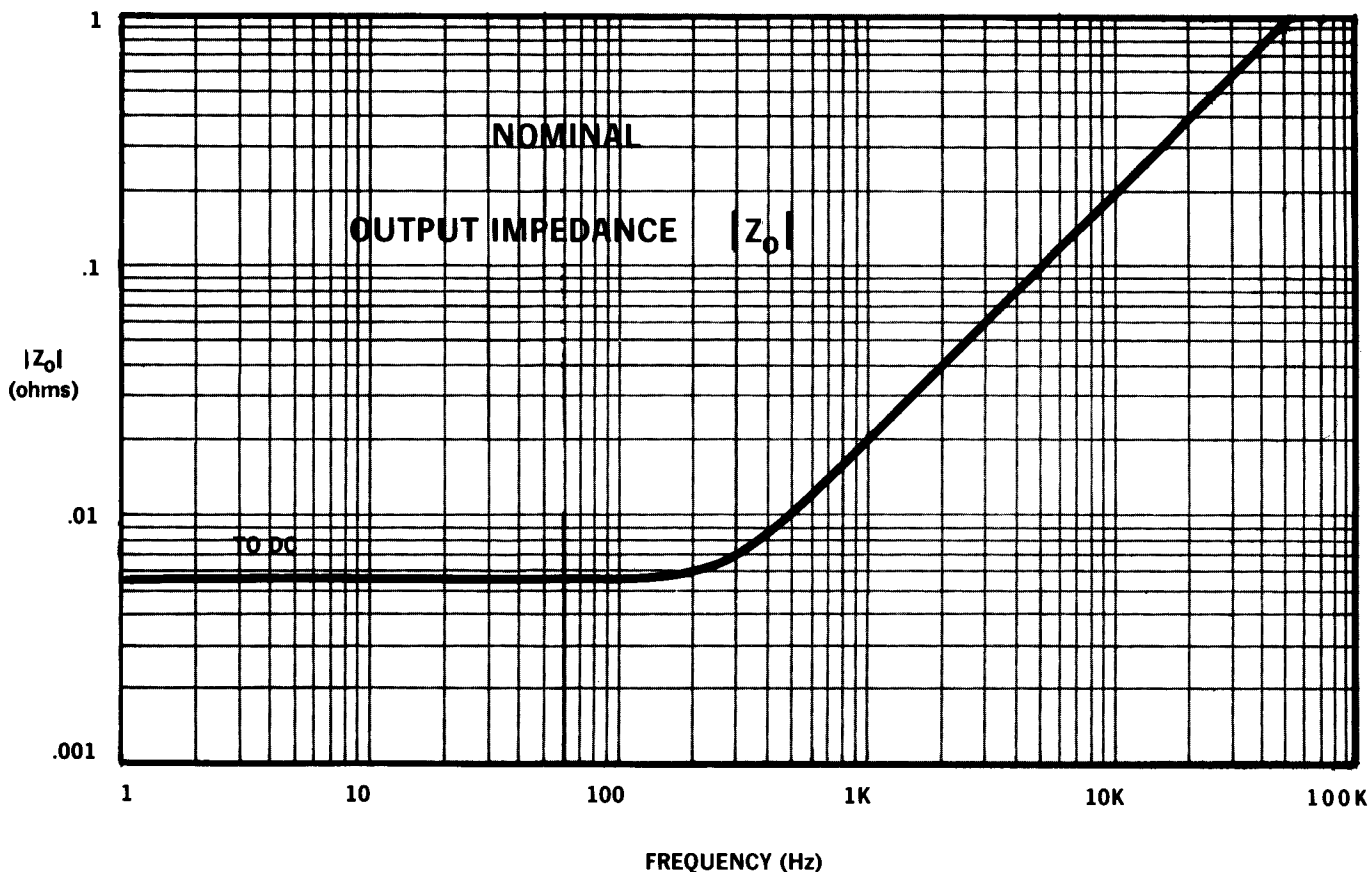

1.3 WARRANTY

CROWN guarantees this equipment to perform as specified. CROWN also warrants the components and workmanship of this equipment to be free from defects for a period of 3 years from date of purchase.

This warranty does not extend to fuses, and/or component or equipment damage due to negligence, misuse, shipping damage or accident; or if the serial number has been defaced, altered or removed.

A copy of the FULL THREE-YEAR WARRANTY is included with this manual. The WARRANTY is subject to the conditions contained therein. Upon receipt of the registration form, CROWN will issue a WARRANTY TITLE. This title applies to the original end-purchaser as well as subsequent purchasers.

You, the purchaser(s), are responsible for accurate, complete records (sales slips, invoices, etc.) for FULL coverage!

INSTALLATION

2.1 UNPACKING

As soon as the amplifier shipment is received, please inspect for any damage incurred in transit. Since the unit was carefully inspected and tested at the factory, it left the factory unmarred. If damage is found, notify the transportation company immediately. Only the consignee may institute a claim with the carrier for damage during shipment. However, CROWN will cooperate fully in such an event. Be sure to save the carton as evidence of damage for the shipper's inspection.

Even if the unit arrived in perfect condition -as most do — it is advantageous to save the packing materials. They will prove valuable in preventing damage should there ever be occasion to transport or ship the unit. Note the carton and internal pack — each is designed for protection during transit, particularly of the power transformer weighing over 25 lbs. *Do not ship the unit without this factory pack!*

2.2 MOUNTING

The DC-3DDA is designed on a standard 19 inch rack mounting format. However, it may be custom mounted if sufficient support is provided. For dimensions see Fig. 2-1. In any circumstance, sufficient ventilation must be provided for the unit. Good ventilation practice allows air to flow completely under, around, and through the amplifier. If the unit is placed above a horizontal surface,

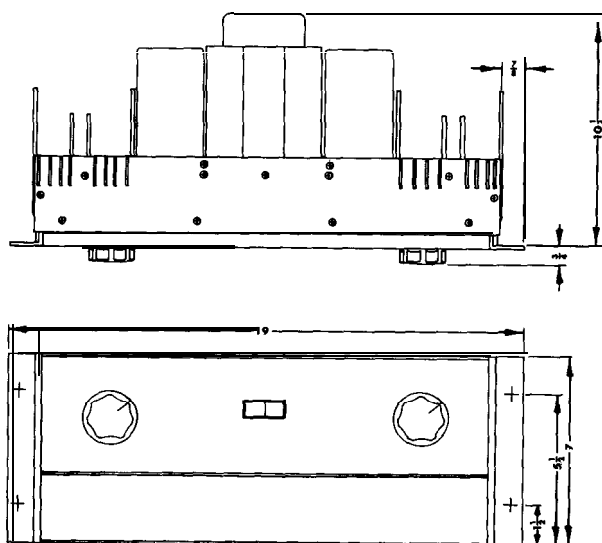

FIG. 2 - 1
MOUNTING DIMENSIONS

an air space should be allowed above and below the unit. If sufficient ventilation is not provided, the unit will intermittently turn off due to the built-in thermal protection. Such a condition (if observed) will also be accompanied by a warm front-panel due to the integral heat-sinking employed in the amplifier.

Applications requiring long sustained signals at high power levels may require the use of a cooling fan.

2.3 NORMAL HI-FI INSTALLATION

1. Remove output covers, exposing dual binding-posts. Two-conductor speaker cables must connect to the OUTPUTS using terminal lugs, tinned ends, or the special "banana" plugs supplied with the DC-300A. Connect the in-line fuses as recommended in the Accessory Bag and Fig. 2-2. (Not needed with CROWN speakers.)

2. Since the DC-300A is a "basic amplifier," the main outputs of the control-center or "preamplifier" must be connected via shielded audio-cables to the two jacks marked INPUT. Use RCA-pin at preamp and standard ¼ inch phone-plug at the DC-300A.

The two cables should be tied parallel along their entire length, using the accessory cable ties.

3. U/L requirements specify a 3-wire AC power connector; however, proper connections to a switched outlet on the control center require the use of a 3-to-2 wire adapter. NOW, plug the AC into a *switched* outlet on the control center.

4. Your Control Center may now be turned on. Then advance the DC-300A Input-Gain Controls about ¾-open (1 50° clockwise).

When using the CROWN IC-150A Control-Center, the VOLUME should attain almost full rotation (2 to 4 o'clock) for loudest "concert-hall" volume. If at 3 o'clock the volume is low, increase the DC-300A input gain controls; if too high, decrease the DC-300A gains.

To assure maximum enjoyment and full speaker protection, read the following detailed sections on OUTPUTS, INPUTS and Chapter 3-OPERATION.

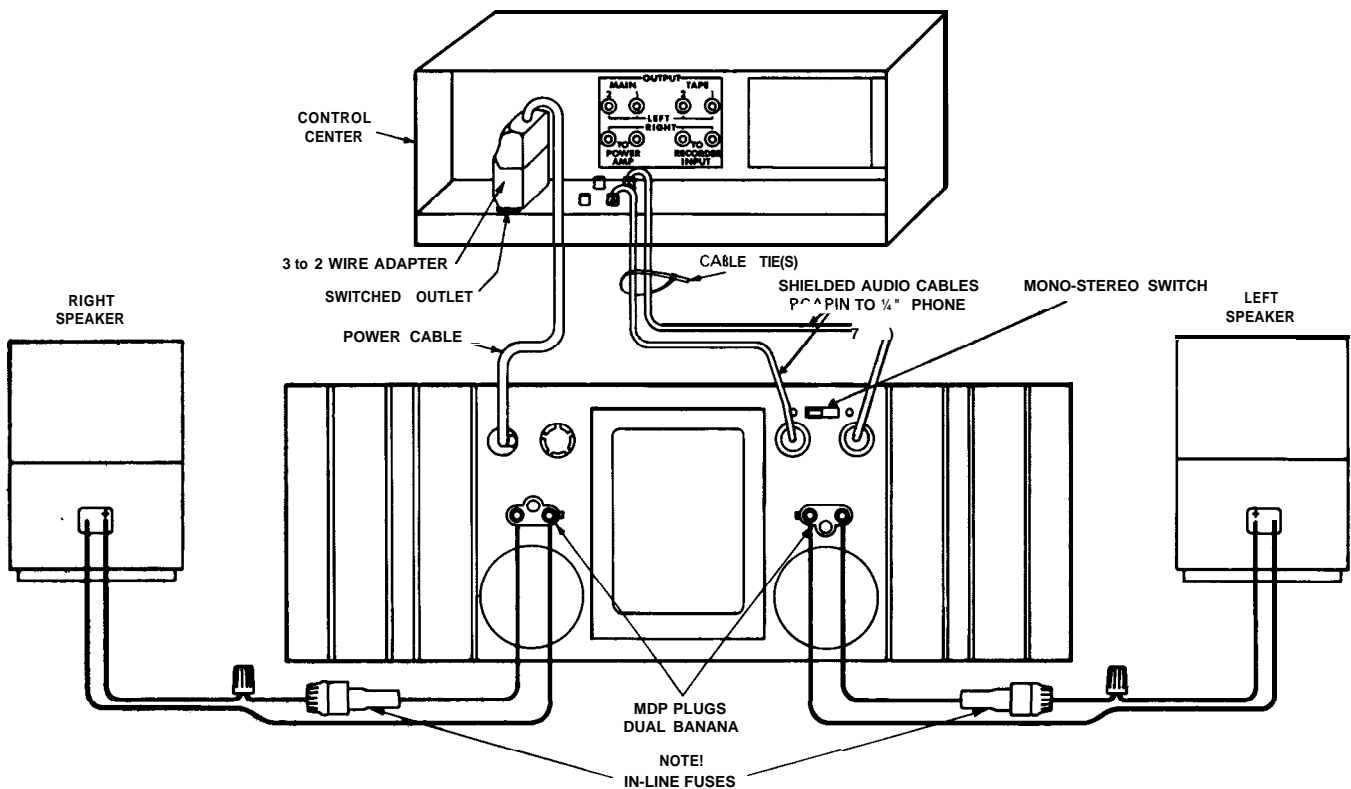

FIG. 2-2
NORMAL HI-N HOOK-UP

2.4 CONNECTING OUTPUT LINES

Input and output connectors are located on the back of the chassis as shown in Fig. 2-3.

It is always wise to remove power from the unit and turn the input level controls off while making connections,

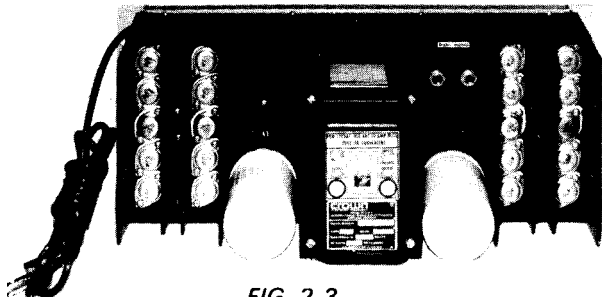

FIG. 2-3
REAR OF CHASSIS
WITH OUTPUT COVERS REMOVED

especially if the load is a loudspeaker system. This will eliminate any chance of loud blasts. CROWN is not liable for damage incurred to any transducer due to its being overpowered! (CROWN speakers excepted.)

Before making connections, it is recommended that the operator familiarize himself with the amplifier's protective system. See Section 3.2. Section 3.3 entitled "Operating Precautions" should also be read.

Because of the location of the output connectors (color-coded binding posts), it will be easiest to make these connections first. High-quality, dual "banana" plugs are the preferred connections for permanent installations, critical applications, and when testing the amplifier.

Because the output wire gauge and length raises the resultant source impedance or lowers the Damping Factor by adding its series resistance, the nomograph (Fig. 2-4)

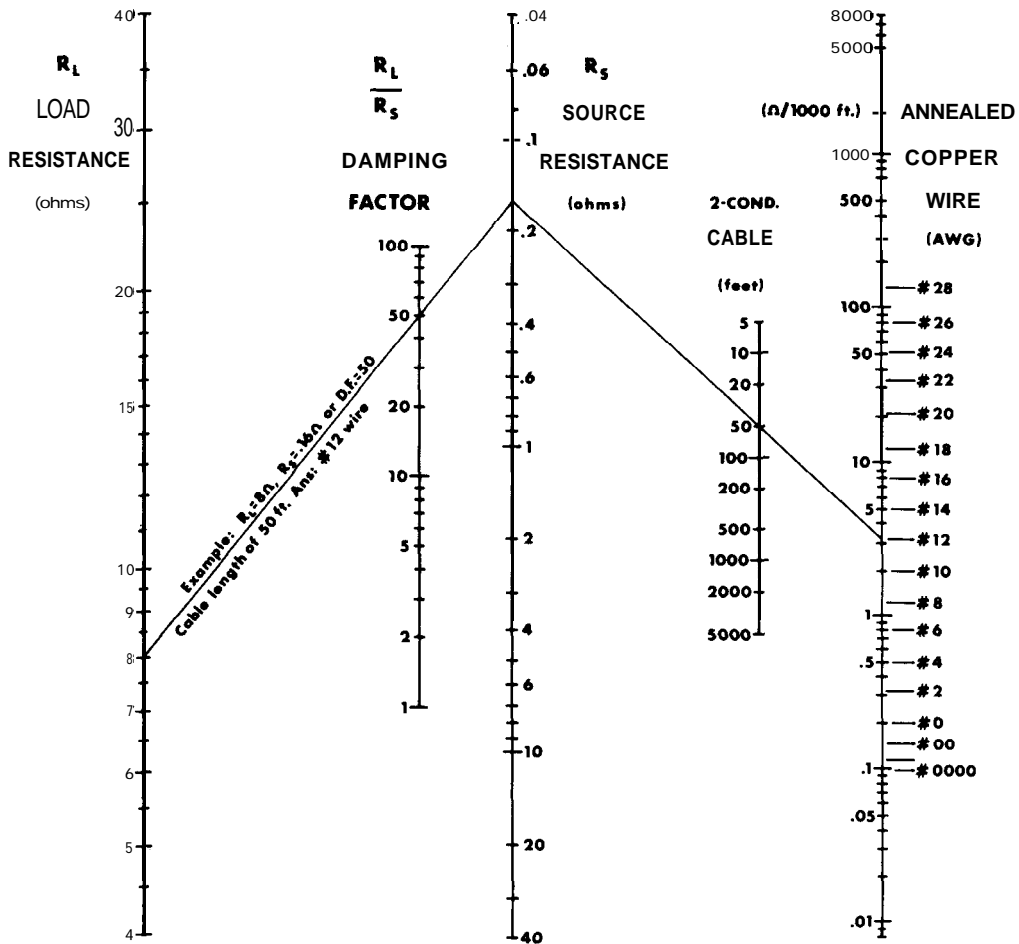
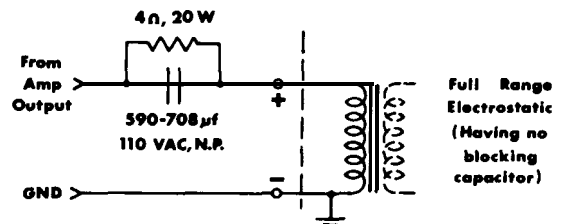

FIG. 2-4
SOURCE RESISTANCE AND DAMPING FACTOR VS. LENGTH AND SIZE OF OUTPUT LEADS

is provided for wire selection. For dynamic moving-coil loudspeakers the value of R_L should preferably be that measured by an ohmmeter across the voice coil, rather than the manufacturer's rating. For electrostatic speakers and such, the manufacturer's rated impedance should be used for R .

If the load (matching transformer, inductance, or full-range electrostatic speaker system) appears as a short-circuit at low frequencies, a large non-polarized capacitor (paralleled with a resistor) should be placed in series with the load.

For electrostatic speakers (if the manufacturer has not provided a capacitor) an external non-polar capacitor of 590-708 mfd and 4 ohm power resistor should be placed in series with the plus (+) speaker lead. This will prevent large low-frequency currents from damaging the electrostatic transformer or from unnecessarily activating the DC-300A's protective systems. An effective test to determine if such parts are needed is to



F/G. 2-5
SCHEMATIC FOR FULL RANGE ELECTROSTATIC SPEAKER CONNECTIONS

measure the DC resistance between the output terminals with an ohmmeter. If the resistance is less than 3 ohms, the parts should be added as shown schematically in Fig. 2-5.

When selecting connectors for the output lines, the following general precautions apply (with all power connectors):

1. A male plug, carrying signal, must not be on the far end of the line where it can be exposed, giving rise to both shock and short-circuit hazards.

- Connectors which might accidentally cause the two channels to be tied together during making and breaking of connection should not be used. A common example is the standard 3-circuit $\frac{1}{4}$ inch phone jack and plug when wired for stereo sound.
- Connectors which can be plugged into AC power receptacles should *never* be used.
- Connectors having low-current-carrying capacity are "verboten."
- Connectors having any tendency to short, or having shorted leads, are inadvisable.

Most commercially-available headphones employ a 3-circuit $\frac{1}{4}$ inch phone plug which violates condition number 2. This is no handicap if a pad is inserted between the amp and jack, which is the only sensible thing to do, when such a large amplifier is coupled to such a small transducer. If this precaution is ignored, not only may the transducer be burned out but permanent hearing loss could result. The recommended pad is shown in Fig. 2-6.

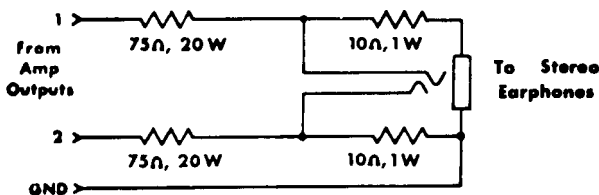

FIG. 2-6
SCHEMATIC OF EARPHONE PAD

2.4.1 MONO OPERATION

A mono-stereo switch on the rear panel adjacent to the input jacks, allows the DC-300A to be operated normally (stereo) or in mono, with no internal modification. (See figure 2-2.) When in the mono position, the input circuitry of the DC-300A is changed so that the two amplifiers are "added" for mono output. (See mono specifications, page 3).

Care must be taken in the external hook-up to assure proper operation. Proceed as follows:

- The input line should be plugged into the channel 1 input jack. The level is adjusted with the channel 1 input level control.

NOTE: The Channel 2 input jack and level control are not defeated in the Mono mode. However, the Channel 2 input should not be used in this mode. If a Channel 2 input is added to the Channel 1 input, distortion may result. If Channel 2 input is used alone, very low power output will result. For best results unplug the input to Channel 2 when operating Mono.

- Connect output lines as per the following drawing, Figure 2-7. The output from the DC-300A in Mono is BALANCED and is isolated from the chassis, and from the input grounds to the DC-300A.

CAUTION: Be certain that all equipment (meters, switches, etc.) connected to the Mono output lines is balanced. Both sides of the line must be totally isolated from the input grounds, to the DC-300A. If this is not observed, severe oscillation may result.

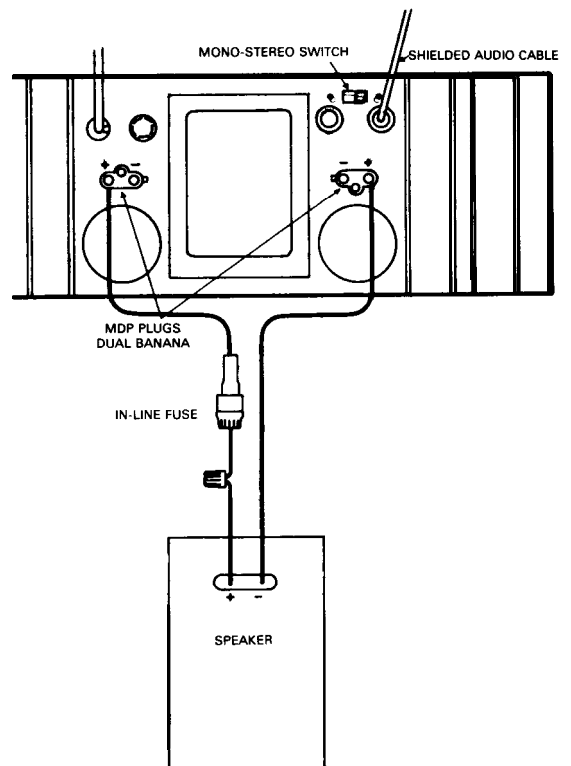

FIG. 2-7
DC-300A MONO HOOK-UP

2.5 CONNECTING INPUT LINES

Connecting the inputs will require avoiding three basic dangers: Undesirable signals to the inputs, "ground loops," and feedback from output(s) to input(s).

For loudspeaker-driving applications, the input should be free of any DC, as this could cause overheating of the loudspeaker voice coil. A simple visual test for DC on the inputs (providing the woofer is visible) is to slowly turn up the input level control with the amp on and watch for any displacement of the cone. If very much displacement is observed, the DC content of the input may be excessive and require a blocking capacitor. The graph of Fig. 2-8 indicates

the effect of the size of the blocking capacitor on the frequency response. Only a low-leakage type paper, mylar, or tantalum capacitor should be used for this purpose.

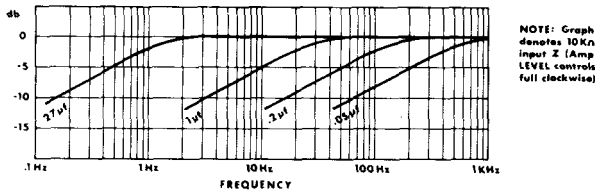

TABLE FOR SELECTION OF INPUT DC BLOCKING CAPACITOR

If large amounts of ultrasonic or RF frequencies are found on the input, such as bias from tape recorders, etc., a low-pass filter should be placed on the input. While practically-obtainable RF input levels will not damage the amplifier, they may cause burn-out of tweeters or other sensitive loads, activate the amplifier's protective systems, or cause general overload in the controlled-slewing-rate stage of the amp (which is employed to provide RF overload protection). The following filters are recommended for such applications.

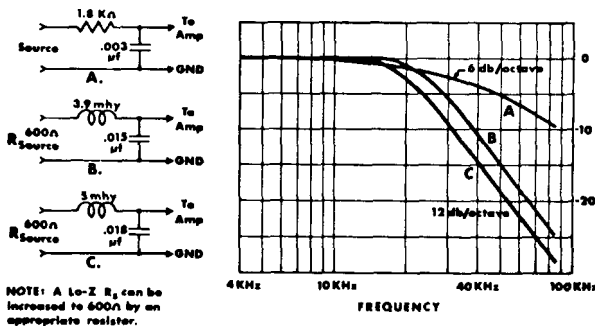

FIG. 2-9

LOW-PASS FILTER FOR SEVERE RF AT INPUTS

A second problem area is "ground loops" — electronic jargon for undesirable circulating currents flowing in a grounding system. A common form of loop (possibly resulting in hum in the output) is a pair of input cables whose area is subjected to a magnetic hum field. In practice, both cables should lie together along their length, and away from the power transformer. Tying the input and output grounds together may also form a ground loop.

A third problem (with input and output grounds together, as in testing or metering) is feedback oscillation, from load current flowing in the loop. In industrial use, even the AC

power line may provide this feedback path. Proper grounding, and isolation of inputs of common AC line devices is good practice. Refer to Section 4.2, par. 5 for testing precautions.

An extremely common form of this problem is encountered when using electrostatic loudspeakers or any other kind of load that is joined to the AC power mains. Capacitive coupling through the load's supplies may allow the amplifier's output to be fed through the AC mains and into the grounds of input equipment resulting in a system oscillation.

To combat the problem, first try reversing the speaker leads on all channels if possible. If this does not solve the problem, try grounding the power amplifier to the AC ground with its 3 wire plug. (A ground loop may result through an FM tuner with an earth-grounded antenna system when deploying the 3 wire plug. The use of .005 μ F disc capacitors in series with the FM antenna leads will eliminate this problem.) All hookup (interconnecting) cables should of course be as short as reasonably possible, and a turntable baseplate ground should always be brought to the phono preamp with a separate ground wire, never via the input cable ground. If the oscillation still persists, start removing input devices, working towards the amplifier until the oscillation disappears. This will identify the point of feedback. If an offending piece of equipment is found it should be inspected for unnecessary AC line-to-ground capacitances such as line filters, etc. If possible such should be removed. Such devices should never be found in the load, although it is true that some RF loudspeakers have used such filters to reduce RFI.

2.6 CONNECTING POWER

The amplifier is furnished with a three-wire AC plug as standard equipment. Adapters are readily available commercially for adapting this to a two-wire system if necessary.

The amplifier offers five standard line-voltage connections: 100, 120, 200, 220, and 240VAC. The tag attached to the line cord indicates for which voltage the amplifier is connected. Most units are connected for 120VAC. When changing the voltage to 200V or above, the external fuse, F1, should be changed from 1 OA to 5A. Relabel the line tag to indicate the proper voltage.

When testing the amplifier, the line voltage must be the peak equivalent to a sinusoid of the indicated line voltage when at full load. Line regulation problems can introduce serious errors in the measurements on an amplifier of this size.

Only a competent technician should attempt alteration of the line voltage connections.

In order to change the voltage, it is first necessary to carefully detach the bottom cover from the unit. On the back of the board-mount subchassis a terminal strip with solder-

on jumpers is used to make the line-to-transformer primaries connections (see Fig. 2-10).

ALL VIEWS WITH BOTTOM PLATE REMOVED

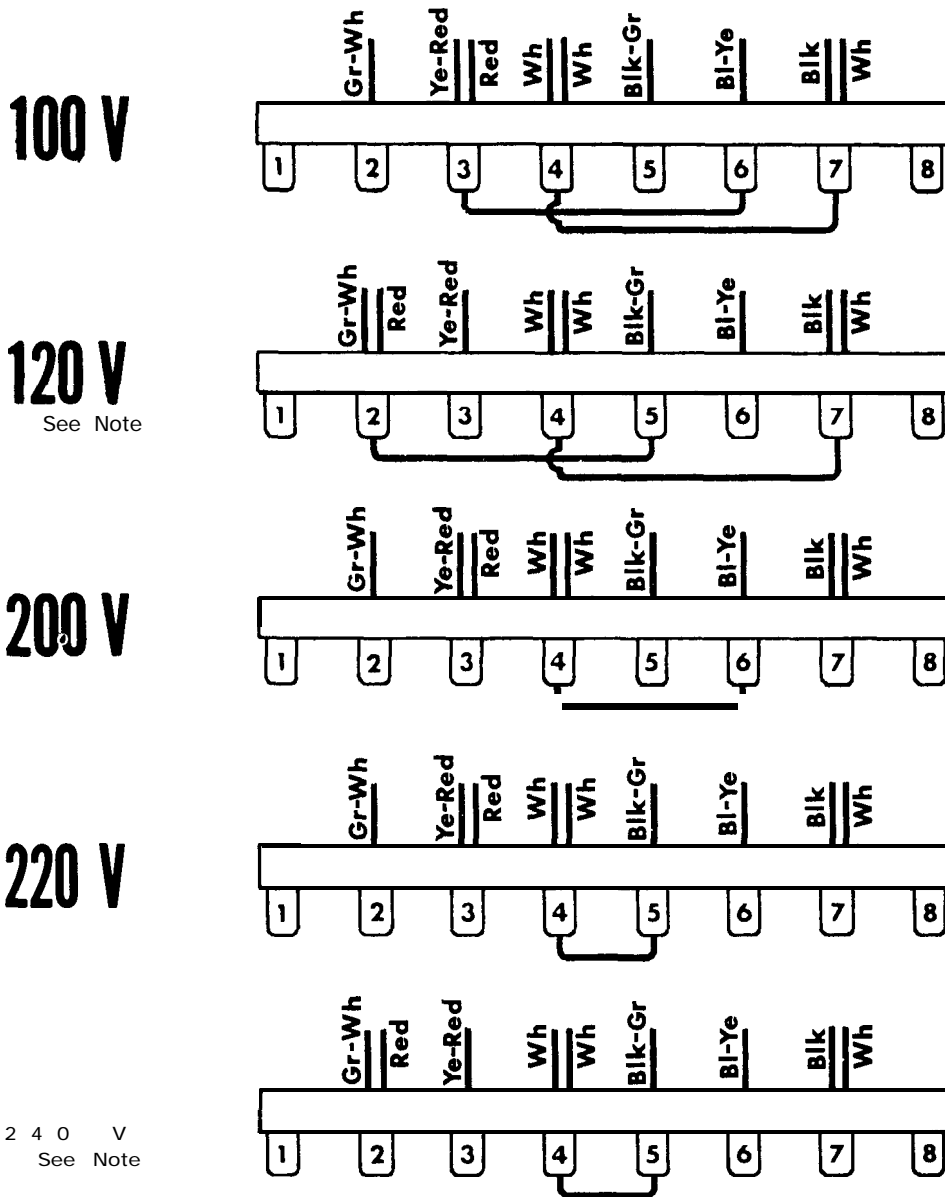

NOTE: The 120V and 240V connections require the changeover of the RED wire from TB-3 to TB-2. Therefore the front panel, control circuit-board and shield must be carefully removed for access. When replacing shield, use care so that on-off switch locates properly in front panel opening!

FIG. 2-10
TABLE OF LINE VOLTAGE CONNECTIONS

3.1 CONTROLS AND ADJUSTMENTS



FIG. 3-1
OPERATING CONTROLS

The DC-300A contains all the facilities essential for a high performance amplifier.

On the front panel are located independent level controls, a power switch, and pilot light. There is an AC line fuse on the rear of the unit.

The level control should be adjusted for the desired amplifier gain or output level. When the control is fully CW, the gain is 26db as determined by precision 1% resistors in the DC-300A's feedback loop.

The DC balance controls located behind the front panel seldom, if ever, need adjustment. *Only* in the most critical applications will they need adjustment (not "hi-fi" or similar applications). To adjust the DC balance controls, use the following procedures (see Circuit Board layout in Section 4):

1. Make sure amp has been allowed at least 15 minutes of warm-up.
2. Set corresponding level control fully CCW.
3. Remove input signal from corresponding input.
4. Place sensitive DC voltmeter across output.
5. Adjust output balance control using small flat-bladed screwdriver for zero reading on voltmeter.
6. Turn level control CW to 12 o'clock.
7. Adjust input balance control using small flat-bladed screwdriver for zero reading on voltmeter.

The DC balance controls are now adjusted.

3.2 THE PROTECTION MECHANISMS

The DC-300A is protected against all the common hazards which plague highpower amplifiers, including shorted, open, and mismatched loads; overloaded power supplies; excessive temperature; chain destruction phenomena; input overload damage; and high frequency overload blowups.

Protection against shorted and low impedance loads is provided by the Signal Programmed Automatic Current Executor (SPACE control). It functions as an automatic current limiter at audio frequencies whose value of current limiting threshold is dependent on the history of the output signal. Output current causes the threshold to decrease while output voltage causes the threshold to increase. The no signal threshold is high enough to allow tone bursting, (even into 4 ohms) without premature limiting as is found in some recent products of other manufacturers

Since the limiter has no instantaneous response to output voltage, flyback transients do not appear in the output when limiting occurs on inductive loads. Flyback transients are a necessary response of a VI limiter (sometimes misnomered an "Energy Limiter") when limiting drive to an inductive load. The actual response of the flyback pulse is that the amplifier yields to the load resulting in a pulse emanating from the load which returns the inductive energy of the load to the opposite polarity power supply of the amplifier as that supply that produced the excessive output. The audible effect of flyback pulses is to produce a rasping, popping sort of sound which is not pleasing.

A current limiter will not yield to the load but will sustain the constant current demands of the inductive load without flyback.

Early amplifier designs frequently employed fixed current limiters but had serious difficulty with obtaining reliable low frequency output while being capable of full-voltage 4 ohm output. Also, many earlier designs used fragile epi-base or triple diffused outputs, which for reliable performance are poor mates for a current limiter protection scheme. The DC-300A uses eight 150W silicon power transistors per channel, chosen for their combination of

current, voltage and response characteristics to allow wide operating safety margins. The safe operating area of each transistor is specified by the manufacturer and individually tested by CROWN. Their toughness allows the reliable use of a current limiter which when rendered signal variable permits larger power outputs than would be safely allowable with a current limiter of fixed type.

At subsonic frequencies, the SPACE control behaves as a VI limiter and provides the increased protection needed at DC to prevent destruction due to heat buildup in the half of the output stage that is being driven.

The fuse inherently protects the power supplies against overload. The AC line for 100, 120VAC is fused with a 1 OA 250V type AB fuse (on 200, 220, 240VAC, 5A type MTH 250V).

The use of any other size fuse will invalidate the warranty.

Never change fuses with power applied!

On each heat sink (see Fig. 2-2) is mounted a thermal switch which protects the amplifier against insufficient ventilation. If either heat sink becomes too hot, the AC line power will be interrupted until the temperature falls to a safe level, whereupon power will be automatically restored. When such an event occurs, the external symptoms are: no indication of AC power (by the pilot), and a warm front panel.

All of the amplifier's voltage-amplifier circuitry is designed to be inherently current-limited. Thereby, if any of the devices should fail, (which is extremely unlikely), no damage will occur to the rest of the stages.

The input stage is protected against overdrive damage by a series limiting resistor should the input signal level ever become very excessive.

The amplifier features a controlled slewing-rate which, coupled with the SPACE controller, protects the amplifier from blowups when fed large RF input signals.

3.3 OPERATING PRECAUTIONS

The following are a number of operating precautions given as an aid to understanding proper *and* improper amplifier usage:

1. Use care in making connections, selecting signal sources, and controlling the output level. The loudspeaker you save may be your own. CROWN is not liable for any damage done to loads due to careless amplifier usage or deliberate overpowering (CROWN speakers excepted). For pointers on load protection see Section 3.4.
2. Never parallel the two outputs by directly tying them together or parallel them with any other amp's output. Such connection does not result in increased power output. Damage incurred by such operation is not covered by the warranty.
3. Never drive a transformer-coupled device or any other device which appears as a low frequency short (less than 3 ohm) without a series isolating capacitor.

Such operation may damage the device and/or needlessly waste output power.

4. Do not short the ground lead of an output cable to the input signal ground as oscillations may result from forming such a ground loop.
5. Never remove fuses with power applied.
6. Operate and fuse the amplifier only as set forth in Section 3.2.
7. Operate the amplifier from AC mains of not more than 10% above the selected line voltage and only on 50, 60, or 400Hz AC. Failing to comply with these limits will also invalidate the warranty.
6. Never connect the output to a power supply output, battery, or power main. Damage incurred by such a hookup is not covered by the warranty.
9. Do not expose the amplifier to corrosive chemicals such as soft drinks, lye, salt water, etc.
10. The amplifier is not recommended for high power industrial usage at frequencies above 20KHz.
11. Tampering in the circuit by unqualified personnel or the making of unauthorized circuit modifications invalidates the warranty
12. Do not expose the output leads to areas likely to be struck by lightning. Such an installation could invalidate the amplifier.

3.4 LOAD PROTECTION METHODS

The most common of all load protection schemes is a fuse in series with the load. The fuse may be single, fusing the overall system. Or, in the case of a multi-way speaker system, it may be multiple with one fuse on each speaker.

Fuses help to prevent damage due to prolonged overload, but provide essentially no protection against damage that may be done by large transients and such. To minimize this problem, high-speed instrument fuses such as Littlefuse 361000 series are most appropriate for such applications. For a nomograph showing fuse size vs. loudspeaker ratings refer to Fig. 3-3.

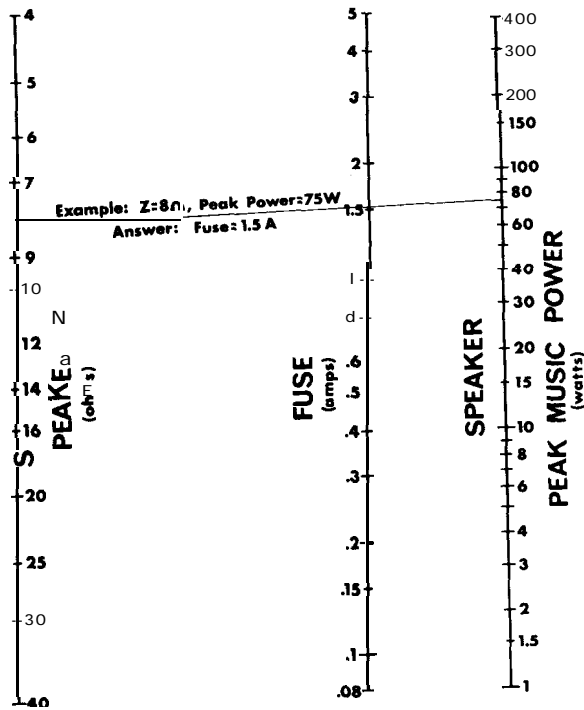

FIG. 3-3
FUSE SELECTOR NOMOGRAPH FOR
LOUDSPEAKER PROTECTION

Another form of load protector is shown schematically in Fig. 3-4. Whenever the load is overdriven, a relay switches a lamp in series with the load, smoothly relieving the overload. The lamp then doubles as an overdrive indicator as it glows. If overdrive is unreasonably severe, the lamp will serve as a fuse. By adjusting the relay tension adjustment and the protection level control, this system is useful from 25 to 200 watts for a typical 8 ohm load.

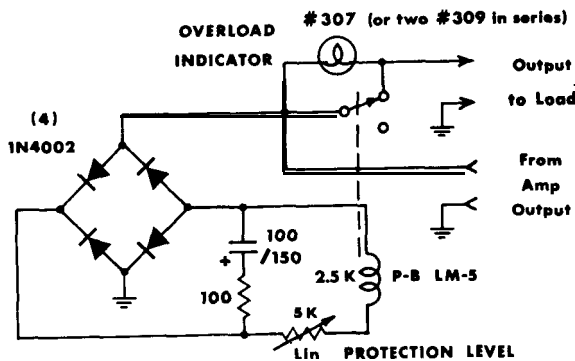

FIG. 3-4
RELAY CONTROLLED PROTECTOR
WITH OVERLOAD INDICATOR

A common problem which causes damage and irritation is the turn-on thump problem typical to many signal sources. Fig. 3-5 shows the schematic of a muter which, when inserted in the input signal line, mutes for several seconds before connecting the source to the amplifier, thereby eliminating turn-on transients. It also removes turn-off transients occurring after the relay drops open (≈ 0.1 sec.).

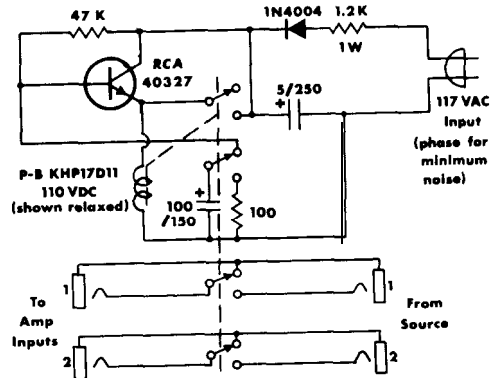

FIG. 3-5
TURN-ON-TRANSIENT MUTER FOR
LOAD PROTECTION

3.5 CLEANING

The CROWN DC-300A has a rugged anodized front panel for life-time service. The panel can be cleaned with a moist cloth and mild detergent. Never use steel wool, scouring powder, lye solution, or any strong abrasive cleaner as these will damage the panel's finish.

The back chassis should require no more cleaning than periodic dusting with a clean dry cloth. The use of detergents, abrasives or other cleaners may remove the fine film of oil from the black anodized chassis which is used to increase its surface lustre.

4.1 PRINCIPLES OF OPERATION

The DC-300A has two totally direct-coupled amplifier circuits which employ a dual IC op amp and silicon transistors in all stages. The CROWN-designed and developed circuit represents a level of quality and performance presently unequaled in the field of audio amplifier design.

As is implicit in the term "totally direct-coupled," the DC-300A has a perfectly flat frequency and phase response extending to 0Hz or DC. Flat to DC response results in not only low frequency amplification with absolutely no phase-distortion, but also in perfect overload characteristics. Non-symmetrical waveforms (such as music) cause overload thumping in all currently produced AC amplifiers. These same amplifiers may, however, show no signs of thumping when fed a symmetrical test waveform such as a sinusoid. DC frequency response combined with ultra-low noise and IM distortion results in the closest approach to a "straight wire with gain."

Another characteristic of a DC amplifier is the thump or pop produced at turn-on and turn-off. For example, at turn-on the input amplifier requires a finite period of time to reach operating levels. During this time the output could be driven to large DC offsets resulting in annoying thumps.

A supply voltage detector virtually eliminates this problem in the DC-300A. The detector disconnects the regulated supply voltages to the output stages during these turn-on and turn-off periods, thus not allowing the DC offsets at the output to occur.

The dual IC op amp is of a low noise type having a large gain bandwidth. The result of using it for the input voltage amplifier is that a maximum amount of feedback is applied reducing distortion to record low values. This has been confirmed by measurement with an elaborate test setup employing CROWN-developed solid-state variable filters and wave analyzing equipment. No other presently available harmonic distortion test apparatus is capable of such low residuals. The 300A's low distortion is achieved by employing multiple feedback loops to allow a maximum of total feedback.

The lack of noise is evidenced by a typical 20Hz-20KHz effective input noise of 1.25u volts which produces an effective 8 ohm output of 80 micro-micro (pica) watts.

The output stage is a quasi-complementary format employing the CROWN class AB+B technique which uses no

bias current in the output transistors. The result is maximum efficiency with minimum crossover notch distortion and amplifier idling-heat. Thus there is no bias current adjustment, as the output circuit is not temperature-tolerance critical. Temperature drifts of bias are further controlled by bias servos which are mounted on the heat sinks.

In the AB+B output circuit, the driver transistors carry the bias current, while the output transistors serve only as boosters. The output transistors (1200W dissipation/Ch) sense when the driver transistors are delivering significant current to the load and take over and deliver the large load currents.

Protection against shorted and low impedance loads is provided by the CROWN-developed SPACE (Signal Programmed Automatic Current Executor) control circuit. It functions as an automatic current limiter at audio frequencies and as a VI limiter at subaudio frequencies. The threshold of current limiting is dependent on the history of the signal, yet the no-signal threshold of current limiting is high enough to allow full power tone bursting. The net result is total protection with a maximum of headache-free output power requiring neither an inventory of special fuses or cumbersome load matching techniques.

The monolithic input amplifier stages result in extremely low DC drift. The input terminal bias current is offset by a unique temperature compensated source resulting in a laboratory amplifier needing no user-accessible offset controls.

The input amplifiers are powered by zener-regulated power supplies. The bias regulators are also powered by zener-regulated current sources with the result that line voltage variations do not cause noise or distortion due to misbiasing.

The power supply is a continuous-duty type, capable of 1 KW loading. The power transformer, weighing 25 pounds, is constructed of special grain-oriented steel. The main DC supplies are full-wave capacitor input type with heavy-duty, chassis heat-sinked diodes. Computer grade electrolytics furnish over 48 joules of energy storage. A higher voltage at low current is derived from a half-wave voltage-doubler circuit. This voltage is used in the amplifier's driver circuit.

The DC-300A represents nothing short of the highest quality in both circuitry and components. It should provide a lifetime of trouble-free service for the most discriminating users.

4.2 TEST PROCEDURES

The sole function of this section is to list precautions essential to obtaining accurate measurements when dealing with high-power, high-purity amplifiers such as the DC-300A.

1. Use the *proper* line voltage, which is the one for which the amplifier is connected. The voltage should be measured throughout the testing with a peak reading meter, and adjusted to the RMS equivalent voltage (to compensate for line voltage regulation errors during the course of the measurements). All measurements should be taken at the power amplifier's plug. When testing for IHF music-power measurements, the line voltage is to be set at 120V when the amplifier is connected to 120V, (IHF standards). If the amp is connected otherwise, the equivalent test may be given by applying the appropriate voltage.
2. The load should be resistive, having less than 10% reactive component at any frequency up to five times the highest test frequency. The resistor should be capable of continuously dissipating the full output of the amplifier while maintaining its resistance within 1% of its rated value. The load should employ only high-current connectors (if any), and be connected to the binding-post output terminals. All output measurements should be taken at the amplifier output terminals, and not anywhere along the output cable through which the load current is flowing.
3. The input level controls should be set to maximum for all distortion tests to assure repeatability of all measurements.
4. When measuring hum and noise, all inputs should be disconnected from the amplifier and the level controls set to minimum or to maximum, preferably minimum.
5. Whenever possible avoid ground loops in the test equipment caused by connecting the output ground to the input ground. *Never* connect the ground of the cable going to the load back to the input ground.

Ground loops are especially obnoxious when measuring distortion. An I-M distortion analyzer, for example, has its input and output terminals tied to a common ground. Such a test should use an ungrounded output return, with the output lead(s) wrapped around the well-shielded and grounded input cable.
6. Always monitor the test oscillator when measuring frequency response. Use a wide-band AC voltmeter; or use the same meter for both input and output level measurements, if the meter's frequency response is known not to be dependent on attenuator settings.
7. Accuracy in measuring voltages for computing wattage is critical. For example, a 2% voltage error together with a 1% resistance error can result in an error of 10 watts power into 8 ohms.

8. Residual distortion and noise levels should be fully known for all the test equipment in order to accurately evaluate the amplifier.
9. Never attempt to measure damping factor by placing abnormal loads on the output. D-F measurements taken during clipping, or any other form of overload, are meaningless. The preferred method is to apply an externally generated current to the output terminals and measure the resultant voltage at the terminals. A convenient current is one ampere — as the resultant voltage will read directly in ohms for $|Z_o|$. Damping Factor is defined as $\frac{|Z_L|}{|Z_o|}$, where $|Z_L|$ is typically 8 ohms. A convenient generator for the 1A current is that amplifier channel not under test. A non-inductive resistance of 8 ohms — coupled between both channels' output terminals — will provide 1A when 8 volts are impressed across the resistor (by that channel not under test).
10. Never measure hum and noise when in the presence of strong magnetic fields. The amplifier should be at least 4 inches away from any large metallic objects or shield plates for a reading to be meaningful.
11. Noise measurements should be taken with a bandpass filter of 20-20KHz. For audio purposes the measurement of noise above 20KHz is meaningless.

4.3 SERVICE

Should service other than routine fuse replacement ever be required, it is recommended that the unit be returned to the factory in the original packing (or replacement, if damaged). For warranty service the machine must be returned to the factory or warranty service station. The CROWN warranty is detailed on page 12.

Because of the level of circuitry sophistication of the DC-300A, only the most competent technicians should be allowed to service it.

Many of the parts are standard items stocked by most supply houses. However, there are several which appear to be standard parts but are actually different. Although standard parts may be used in an emergency, best results will be with factory parts. A number of the parts are available only from CROWN.

When ordering parts, be sure to give the amplifier serial number as well as the part number and description. Rated firms will be billed, otherwise shipments will be C.O.D.

Before returning an amplifier to the factory for service, authorization should first be obtained from the service manager. Shipments may be sent UPS or truck freight, prepaid and insured at total value. The factory will return your serviced unit by UPS or truck freight, collect. and will add C.O.D. charges in the event that the cost is not covered by registered warranty.

APPLICATION NOTES

APPLICATION NOTE NO. 1

V-I LIMITS OF A LOAD

Evaluating the V-I (volt-ampere) needs of a load: Many loads exhibit large reactances (or energy storage), which limits a power amplifier's ability to deliver a maximum power. If a load stores energy, which in turn flows back into the amplifier, it is clear that the maximum power efficiency of the system is not being achieved. Power that flows back into a linear amplifier must necessarily be dissipated in the form of heat. A pure reactance is not capable of dissipating any power; therefore to drive such a load would only cause power amplifier heating.

In practice all loads exhibit some energy dissipation — however large their energy storage characteristics may be. The ideal coupling to any load is one that optimizes the desired dissipation component while minimizing the reactive or stored-energy component that is seen by the amplifier's output terminals.

In applications where the input is sinusoidal and of small proportional frequency deviation, a relatively stable load may be resonantly tuned to present a real value of impedance to the amplifier.

Any load, no matter how complex its behavior, has a V-I operating range which may be mapped by the following test.

The maximum voltage and amperage excursions in all directions about zero (center of scope screen) define the volt-ampere operating range of the load. If a load is known to be linear over its operating range it is not necessary to supply the maximum desired power to the load. The test may be conducted at low signal levels and the current-sensing resistor (indicated as 0.1 ohm) may be enlarged to a convenient value for the oscilloscope's deflection sensitivity. The resulting plot may be then linearly scaled to the desired operating level.

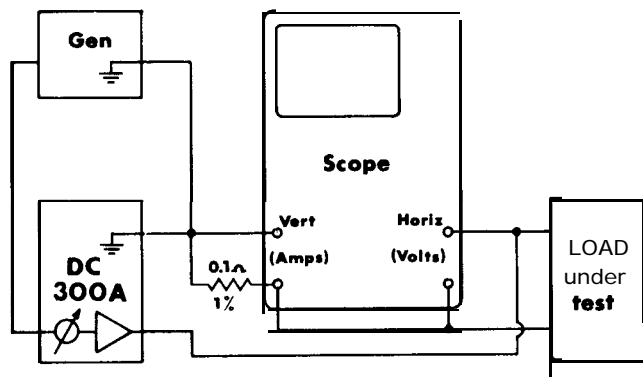

Note: Scope and amplifier grounds are not common. Vertical input reads (-) amperes vertically. If scope has an inverter, invert to read (+) A.

AMPLIFIER LIMITS OF VI OUTPUT

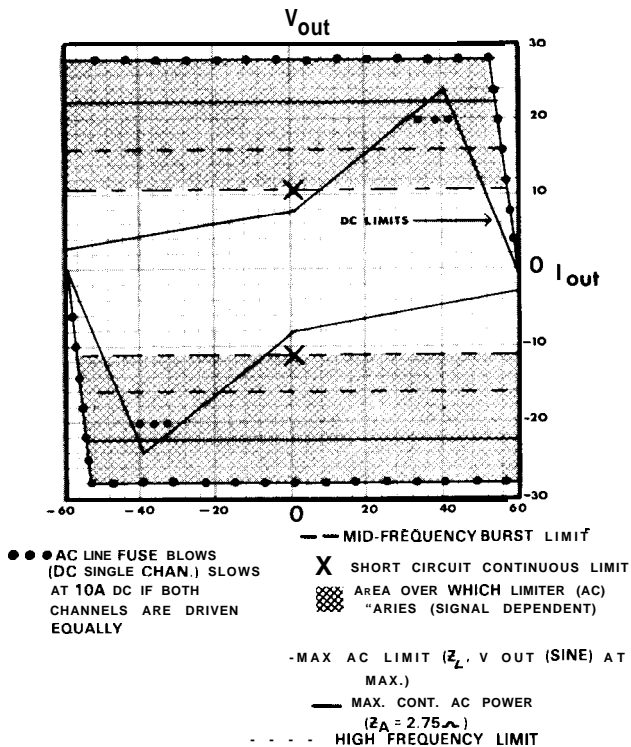

APPLICATION NOTE NO. 2

VFX-2

The CROWN VFX-2 is a dual-channel variable electronic filter-crossover. When used with a power amplifier it can greatly add to the total system capability. In combination with the DC-300A, the VFX-2 adds several convenient useful functions.

The connections are made with the VFX-2 quickly and easily. If a balanced line is to be used with the unbalanced input of the DC-300A, the VFX-2 can serve as the interface. While maintaining these functions the output can be shaped by selecting variable high-pass, lo-pass, or band-pass filters. As a filter, the VFX-2 can be used as a cross-

over or ahead of several amplifiers in a bi- or tri-amped system.

Overall noise and distortion are extremely low, with IM distortion less than .01% at rated output (2.5V into 600 ohms), and noise more than 100dB below rated output with 0dB gain.

For further information please request the VFX-2 specification sheet or for a nominal fee, purchase a VFX-2 instruction manual.



APPLICATION NOTE NO. 3

WARNING

POWER AMPLIFIER PROTECTION SYSTEMS PROTECT AMPLIFIERS BUT NOT SPEAKERS! YOU, AND/OR YOUR SPEAKER MANUFACTURER ARE RESPONSIBLE FOR SPEAKER PROTECTION!

Except in unusual sets of circumstances, the circuitry included in power amplifiers designated as "protection", whether made up of transistor limiters, circuit breakers, fuses, SCR's, or whatever, is designed primarily to protect the amplifier from damage and will only protect speakers incidentally. There are some exceptions to this rule, which allow the user to vary the output power limits of his amplifier to match the power rating of his speakers. Even this, however, is a far from perfect speaker protection scheme. The reason why this holds true is simple: each make or model speaker has its own unique operating capabilities. As a rule, a speaker system (including all electronics parts such as crossover parts and electrostatic element transformers, as well as voice coils) will be able to dissipate a certain amount of power continuously without burning up. This depends on the size, quality, configuration, etc., of those parts. The same speaker will be able to handle a somewhat **higher** power level for a short period of time (in the millisecond range) without being destroyed by heat, but may then be endangered by such phenomena as extending moving elements beyond their normal range of travel (bottoming, torn diaphragm, etc.), overvoltageing electrostatic panels (arcing), or other such suddenly disabling events. Since the points at which these disastrous happenings will occur, differ for different speakers, a speaker protection system must be completely adjustable if it is to be useful for more than a narrow range of speakers. Furthermore, if the user is to be able to do adequate adjustment on a protection system external to his speakers, he must receive accurate information about the speaker power handling capabilities from the speaker manufacturer. Speaker protection systems embodied in amplifiers are comparatively useless, therefore, unless the following things are true:

- (1) The protection system can be accurately adjusted by the user.
- (2) The power handling capabilities of the speakers are clearly stated by the manufacturer.
- (3) The information about the speaker protection and speaker power handling are stated in common terms so that the user can adjust the protection properly for the speaker.

These three things are rarely true simultaneously. It is for this reason that CROWN takes the approach that speaker protection is the responsibility of the speaker manufacturer. Amplifier manufacturers have long been required to provide protection in their products for any faults occurring externally to the amplifier outputs, such as speaker short circuits, open circuits, etc. In order to

fairly share the responsibility, and since the protection cannot be exhaustively provided any other way, we feel that speaker manufacturers should provide protection tailored to their individual products. At CROWN we have done this with our own speakers, simply because it is the only comprehensive means of providing worthwhile protection for all of our speakers.

Increasing power available from modern amplifiers increases the danger of speaker damage. Although occasionally an internal amplifier malfunction can contribute to speaker failure, it is much more likely that speakers will be overpowered by inadvertant use of too much power. In the absence of internal protection in most speaker systems, CROWN recommends very strongly that in-line speaker fuses be employed in all systems. The fuse selection nomograph reprinted in each CROWN amplifier manual can be an invaluable help in choosing fuses of the proper size. However, the effectiveness of fuses in protecting speakers is limited in two important ways

- (1) Fuses as a rule protect only against prolonged overpowering, and can only prevent speakers from being driven with more than their RMS or average power rating. Fuses cannot protect against sudden high level transients of short duration. The use of high-speed instrument fuses will give the best protection available from fuses, but musical transients can have an effect before the fastest fuses blow.
- (2) An appropriate fuse can only be selected if the manufacturer's specifications for his speaker are accurately and clearly stated. If a speaker can handle 100 watt peaks and 30 watts continuously, but is advertised, and therefore fused, as a 100 watt speaker, then the speaker will destroy itself before the fuse can protect it under a continuous power level above 30 watts.

There are more effective (also more complicated and expensive) methods of protecting speakers than fuses. Some of these, including methods similar to those employed in CROWN speakers, are illustrated in the load protection section of CROWN amplifier manuals. But these systems, as all others, must still be adjusted in accordance with the power-handling capability of the speakers IN use, and this can still be most readily done by speaker manufacturers.

Your speakers have probably cost you at least as much as any other part of your audio system. And since speaker sound continues to be the most subjective area of component selection, you may also have devoted more time and effort to selecting your speakers than you have devoted to any other part of your system. With these facts in mind, be extremely careful in providing for adequate protection of these often fragile, but most important, expressions of your audio taste.

Schematic Designation	Description	Crown Part #	Other Information
	MAIN BOARD	41602 ML	
	Capacitors		
C100, C200	100 PF Mica	3410	
CI 01, C201 C104, C204 C111, c211 CI 14, C214 C119, c219	200 PF Mica	3411	
C102, C202	.001 MF Ceramic Disc	2288	
C103, C203	47 PF Mica	3409	
C105, C205	120 PF Mica	3290	
C106, C206	82 PF Mica	3627	
CI 07, C207	20 PF Ceramic	3535	When outputs are 3941
CI 07, C207	10 PF Mica	2821	When outputs are 3937
CI 08, C208 CI 09, C209	25 MF, 15V NP Vertical	3186	
CI 10, C210 c7	.01 MF Ceramic Disc	1751	
c112, c212	.012 MF, 200V Filmatic	3219	
CI 13, C213 CI 20, C220	.0027 MF, 200V Filmatic	3481	
c121, c222	.0022 MF	3285	
c4	10 MF, 150V	2796	
c5	10 MF, 50V Vertical	3728	
C6	100 MF, 16V Vertical	3729	
	Resistors		
R101, R201	2M ohm ¼ watt 5%	3199	
R102, R202 R111, R211	1K ohm ¼ watt 10%	2627	
R103, R203	250K ohm, horizontal pot	3087	Input offset pot
R104, R204	10K ohm ¼ watt 10%	2631	Omitted when R100,200 is 25K
R 105, R205	100K ohm, horizontal pot	1709	Output offset pot
R106, R206	820K ohm ¼ watt 10%	3623	
R107, R207	3.3K ohm ¼ watt 10%	2629	Used when IC-1 is uA749, omitted when uA739
R 108, R208	4.7K ohm ¼ watt 10%	3939	
R109, R209	510 ohm, ½ watt 1% MF	3304	

Schematic Designation	Description	Crown Part #	Other Information
R110, R210 R10	10K ohm ½ watt 1% Film	2343	
R112, R212 R5	8.2K ohm ¼ watt 10%	2877	
R113, R213	5.6K ohm ¼ watt 10%	3220	
R114, R214	68K ohm ¼ watt 10%	3620	
R115, R215 R121, R221	820 ohm ¼ watt 10%	3301	
R116, R216	82 ohm ¼ watt 10%	3300	
R117, R217	470 ohm ¼ watt 10%	2626	
R118, R218 R119, R219 R124, R224 R125, R225	120 ohm ½ watt 5% Film	3837	
R120, R220 R123, R223	15K ohm ½ watt 10%	1064	
R122, R222 R3	3.3K ohm 1 watt 5%	3617	
R126, R226	15 ohm ¼ watt 10%	3614	
R127, R227	2.2K ohm ½ watt 5% Film	3145	
R128, R228	750 ohm ¼ watt 5%	3509	
R129, R229	Sel		
R130, R230	47 ohm ¼ watt 5%	1011	
R146, R246	2.4K ohm ¼ watt 5%	3616	
R147, R247	100 ohm ¼ watt 10%	2872	
R148, R248	56 ohm ¼ watt 10%	3511	
R149, R249	180K ohm ¼ watt 10%	2884	
R1	1K ohm 1 watt 10%	3615	
R2	2.2K ohm ½ watt 10%	1036	
R4	200K ohm ¼ watt 5%	3622	
R6	91K ohm ¼ watt 5%	3621	
R7	6.2K ohm ¼ watt 5%	3619	
R8	3.9K ohm 1 watt 10%	3618	
R9	2.7 ohm ½ watt 10%	2857	Wired between main board and terminal strip on main shield
R11	75 ohm ¼ watt 5%	3798	
Semiconductors			
Q103, Q203 Q119, c1219 Q120, Q220	2N4125	3625	

Schematic Designation	Description	Crown Part #	Other Information
Q100, Q200 0101, Q201	MPSA93	3578	
Q102, Q202 Q105, Q205 Q1	2N3859A (selected)	2961	
Q104, Q204	NSD128	4061	
Q106, Q206	RCA 61061 (selected)	3348	Positive pre-driver
Q107, Q207	2N4929 SS7304	2923	Negative pre-driver
Q2	PN4250A	3786	
D100, D200 D101, 0201 D102, 0202 D103, D203 D104, D204 D105, D205 D106, D206 D107, 0207 D111, 0211	1N4148	3181	
D108, D208	1N270	3447	
D1, D2	1 N4003	2851	
D3, D4, D5	1N961B10V zener	3549	
	Integrated Circuits		
IC-1A,B	uA739 or uA749	3231 3643	R107, 207 omitted R107, 207 is 2629
	Coils		
L100, 200 L102, 202	.5 mhy axial lead	3510	
	Miscellaneous		
	Main PC board	9605	
	TO-5 mounting pad	1250	Used to mount pre-drivers (Q106, 206, 107, 207)
	TO-5 coolers	3175	Mount on pre-drivers
	IC socket, 14-pin DIL	3450	
	TO-92 dual cooler	3493	Used on Q101, Q201
	PC receptacle	3519	
	#8 x 5/8 hex WHSMT screw	2757	Fasten main board to shield
L101, 201	OUTPUT INDUCTOR ASSY.	41206	
	Torroid form	2850	
	Magnet wire, #14 (13" lg)	3630	Wound on form 2850

Schematic Designation	Description	Crown Part #	Other Information
	Captive stud, #10 x 1 1/4	3636	Used to mount coil assy.
	Nylon washer	3609	One used on each side of coil
	Nylon spacer	2762	Used in center of coil; over stud 3636
	#10 internal star lockwasher	2279	To mount coil
	Hex nut, 10-32	2170	To mount coil
	Solder lug 806, #10	3312	Mounted under nut; under coil
	HEATSINK BOARD ASSY.	41207	
	DC-300 heatsink	3561	
	Heatsink PC board	7954u	
	Capacitors		
CI 15, C215	.01 MF Ceramic Disc	1751	On PC board
CI 17, C217	.22 MF, 100V Filmatic	3218	On heatsink
	Diodes		
D109, 0209 D110, D210	1N4003	2851	On board
	Resistors		
R131, R231 R138, R238	180 ohm 1/4 watt 10%	2873	On board
R132, R232 R139, R239	5.6 ohm 1 watt 5% or 12 ohm 2 watt 1%	2355 3931	On board See chart on schematic
R133, R233 R134, R234 R135, R235 R136, R236 R137, R237 R140, R240 R141, R241 R142, R242 R143, R243	.33 ohm 5 watt 5% Wire	3583	On board
SW-2 SW-3	Thermal switch SPST NC 1 60°F	2799	One mounted on left heatsink, one on the right
	Transistors		
Q108, Q208	2N3859A (selected)	2961	Attach to heatsink with 2162 compound
0109, 0209 Q114, Q214	TIP558 (selected)	4025	Driver transistors

Schematic Designation	Description	Crown Part #	Other Information
Q110, Q210 Q111, Q211 Q112, Q212 Q113, Q213 Q115, Q215 Q116, Q216 Q117, Q217 Q118, Q218	Sel. 1605 (RCA) or 2N5631; 1 OOV (Motorola)	3937 3990	Output transistors
	Miscellaneous		
	TO-3 anodized insulator	4039	Mounts outputs and drivers
	TO-3 insulator	407 1	Mounts outputs and drivers
	Heatsink compound, 340	2162	Mounts outputs and drivers
	#6 internal star lock washer	1823	Mounts outputs and drivers
	6-32 hex nut	1889	Mounts outputs and drivers
	6-32 x 3/4 BHP screw	2135	Mounts outputs and drivers
	#6 solder lug, 505	3163	Used as terminals on board and heatsink
	FRONT PANEL ASSY.		
	DC-300A Chassis cover	9561S	
	1 O-32 x 5/16 captive stud	3635	
	6-32 x 1/4 BHP screw	1954	
	3/8 internal star lockwasher	2188	
	Cable ties	1811	
	,375 hole solder lug	2828	
	Front panel extrusion	4087	
	Front panel overlay	4088	
	Knobs	4080	
	3/8" bright nut	1288 NIC	
	Bright washer	2189 NIC	
	Carrier strip	3638	
R100, R200	25K ohm audio ZF3448	2942	Level controls
	Rack ears	20030	
	SHIELD ASSY.	41202	
	Main board shield	95928	Mounted on spacers
	Brass shield spacer	3581	Mounted on transformer screws (1 O-24)
	8-32 x 3/8 THP screw	2155	To mount shield on transformer spacers

Schematic Designation	Description	Crown Part #	Other Information
	Brass tube	3637	To mount power switch
	6-32 x 1 ¼ BHP screw	3634	To mount power switch
	G-6-G terminal strip	3503	Mounted on shield
	6-32 x ¾ BHP screw	2134CAD	To mount terminal strip
	6-32 hex nut	1889	To mount terminal strip
Added after SN A71 14	G-6-G insulator	3600	Under terminal strip
	#6 internal star lockwasher	1823	To mount terminal strip
	¼" expansion nut	2544	Mounted on shield in square holes
	#8 x ⅝ SMT hex screw	2757	Used to secure main PC board to shield
Cl. c2	13,500 MF, 70V	3436	Mounted on heatsink
	.218 solder lug	2934	Positive capacitor uses 2 on each terminal; on top of 3320
	10-32 x ½ THP screw	2049	Used to mount capacitor
	Fiber shoulder washer	3320	Mounted inside 1309 to insulate screw
	Nylon washer	1647	Mounts over capacitor terminals
	Flat metal washer	3830	Mounts between 3320 and 2934
	TRANSFORMER ASSY.	41204	
T1	Power transformer 46P6E	4004	Supplied with mounting screws (10-24)
	#10 solder lug, 806	3312	Used under 3581 spacer and 2829 nut for gnd. lug (3 position only)
	#10 internal star lockwasher	2279	Used over transformer screws; one in position not having 3312 lug, 4 on top of 2829 nuts
	#10-24 hex nuts	2829	To mount transformer
	Panel washer	3830	Used between 2829 nuts and 3581 spacer
	Solder lug	3664	Used over one 3581 spacer to secure input cables
	Foam tape	1152	
	120V serial plate	3883	
	CHASSIS COVER ASSY.	41209	
	Chassis cover	9561 S	
DMI	Bridge, SDA9903, 30A	3526	On chassis cover
c3	.1 MF, 200V Filmatic	2938	On bridge assembly
	Heatsink compound	2162	Use to mount bridge

Schematic Designation	Description	Crown Part #	Other Information
	#6 internal star lockwasher	1823	Use to mount bridge
	6-32 hex nut	1889	Use to mount bridge
	6-32 x 1/2 BHP screw	2176	Use to mount bridge
	1 O-24 x 3/8 self-tap screw	4035	Use to mount cover to heatsink (chassis)
F2	ABC 12A internal fuse (CSA)	3772	
	HTA fuseholder	3256	Supplied with nut and rubber washer
	Fuse block	3776	
F1	1 OA 3 AB fuse	2819	
F1	5A ABC fuse	3774	Used when 240V
	Strain relief	3582	Used to secure power cord
	112A 2-conductor hi-D jax	3423	Input jacks
	3/8" fiber shoulder washer	1306	Used to mount jacks
	Fiber flat washer	1646	Used to mount jacks
	Dual binding post	2823	Output connectors
	#6 solder lug, 505	3163	Mounted on negative terminal of 2823
	250 faston terminal	3298	Used to connect wires to bridge and
	250 faston terminal housing	3297	thermal switch
C116, 216	5 MF, 70V	1678	Mounted on dual binding post 2823
Cl 18, 218	.1 MF, 200V Filmatic	2938	Mounted on dual binding post 2823
R144, 244	5.6 ohm 1 watt 5%	2355	Two in parallel per channel for 2.7 ohms
R145, 245	1 ohm 1/2 watt 10%	3612	Mounted on dual binding posts
	Power cord 3 #18 male	3474	
	8-32 hex nut	1986	
	8-32 x 3/8 RHS screw	2226	
	#10 solder lug	3312	
SW-1	Power switch	20020	Faston terminal attached to one wire
	250 faston flag	3901	
	250 faston flag housing	3297	
	HI-FI ADAPTER KIT	40377	
	3AG pigtail fuseholder	3060	
	5 x 8 zip-lip poly bag	3073	
	Dual banana plug	2981	
	3AG 1.5A fuse	2957	
	Model 74B wire nut	3069	
	Pin-phone cable	3339	
	10-24 panel thumbscrew - washer assy.	20032	

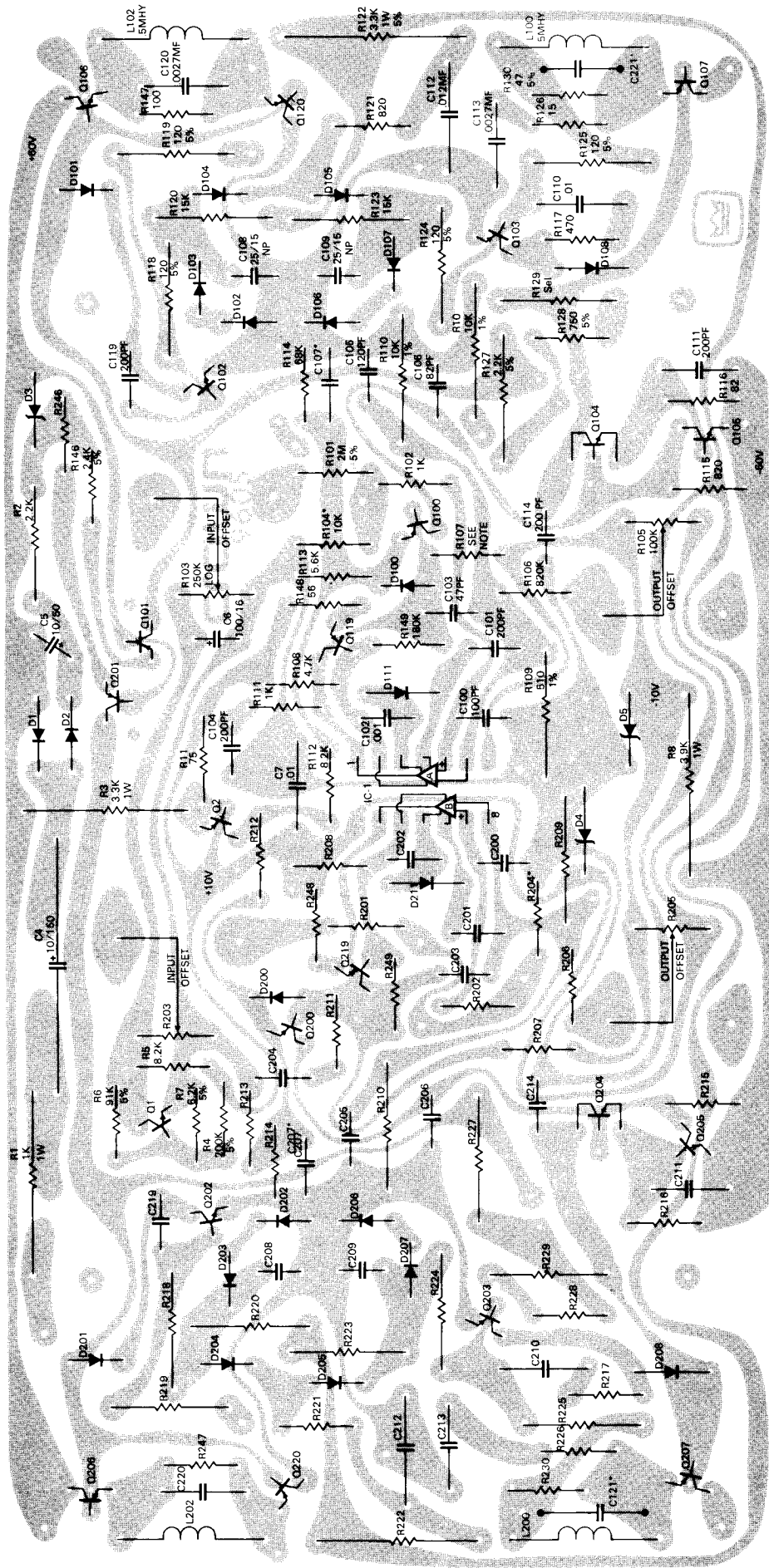

- NOTES:
- CIRCUIT SHOWN STARTS SN A-15277; APPLIES ONLY TO SCHEMATIC NUMBER MI-250B.
 - ALL RESISTANCE IN OHMS. CAPACITANCE IN MICRO-FARADS UNLESS OTHERWISE NOTED.
 - COMPONENTS COMMON TO BOTH CHANNELS NUMBERED 1-99; CHANNEL ONE, 100-199; CHANNEL TWO, 200-299.
 - VALUES SHOWN FOR CHANNEL ONE ONLY; CHANNEL TWO IDENTICAL.
 - FOIL SIDE SHOWN.
 - R104/R204 OMITTED IF LEVEL CONTROLS ARE 25K LOG.
 - R107/R207 OMITTED IF IC-1 IS uA739, 3.3K IC-1 IS uA749.
 - *FOR VALUES OF C107, C207 AND C121, C221 SEE SCHEMATIC.

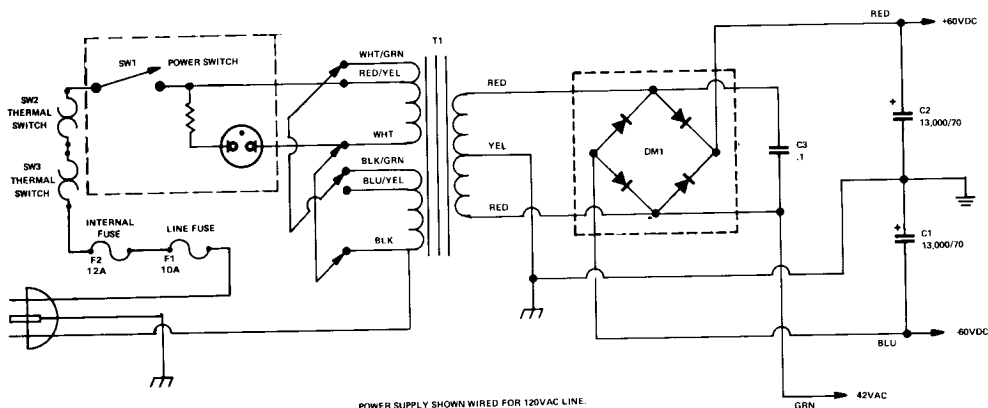

POWER SUPPLY SHOWN WIRED FOR 120VAC LINE.
 FOR 240VAC, CHANGE F1 TO 5A. REMOVE THE TWO JUMPERS SHOWN AND CONNECT A JUMPER FROM THE WHT TO THE BLK./RED TRANSFORMER LEADS.

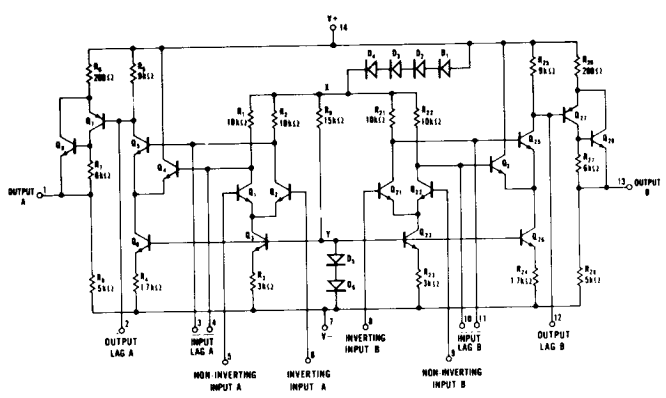

NOTES:

- APPLIES TO PC BOARD NUMBER 9605 ONLY.
- CIRCUIT SHOWN STARTED SN A-15277, MONO-STEREO SWITCH (SW-4) STARTED SN 16001.
- DC VOLTAGES ARE SHOWN FOR VARIOUS POINTS. THESE ARE THE NORMAL OPERATING VOLTAGES FOR ZERO INPUT.
- THE HEAVY CONTINUOUS TRACE FOLLOWS THE PRIMARY SIGNAL PATH THROUGH THE CIRCUIT. THE HEAVY BROKEN TRACE SHOWS FEEDBACK PATHS.
- WIRE COLOR CODES ARE GIVEN FOR THE MAIN POWER SUPPLY AND SOME BOARD WIRES.
- ALL RESISTORS IN OHMS UNLESS OTHERWISE STATED.
- ALL CAPACITORS IN MICRO-FARADS UNLESS OTHERWISE STATED.
- COMPONENTS COMMON TO BOTH CHANNELS ARE NUMBERED FROM 1 TO 99.
- CHANNEL ONE COMPONENTS ARE NUMBERED FROM 100 TO 199.
- CHANNEL TWO COMPONENTS ARE NUMBERED FROM 200 TO 299.
- IF R100/R200 ARE 25K LOG, OMIT R104/R204. R107/R207 ARE OMITTED IF IC-1 IS μ A739, 3.3K IF IC-1 IS μ A749.

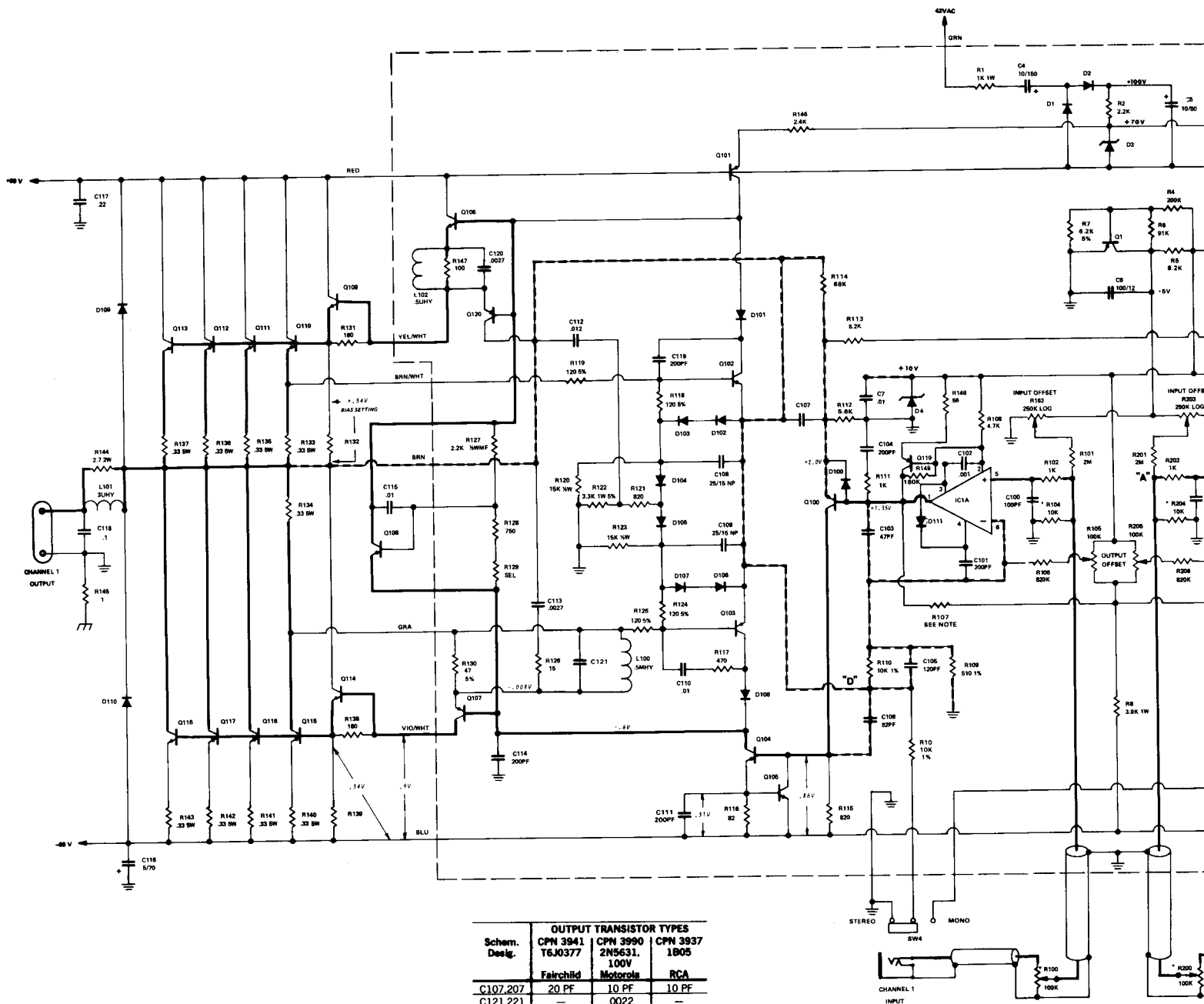

Schem. Desig.	OUTPUT TRANSISTOR TYPES		
	CPN 3941 T6J0377 Fairchild	CPN 3990 2N5631, 100V Motorola	CPN 3937 1805 RCA
C107.207	20 PF	10 PF	10 PF
C121.221	—	.0022	—
R132.232 139.239	5.6Ω1W	5.6Ω1W	6Ω2W
R126.226	15Ω1/4W	15Ω1/4W	15Ω1/4W
C113.213	.0027 MF	.0027 MF	.0027 MF

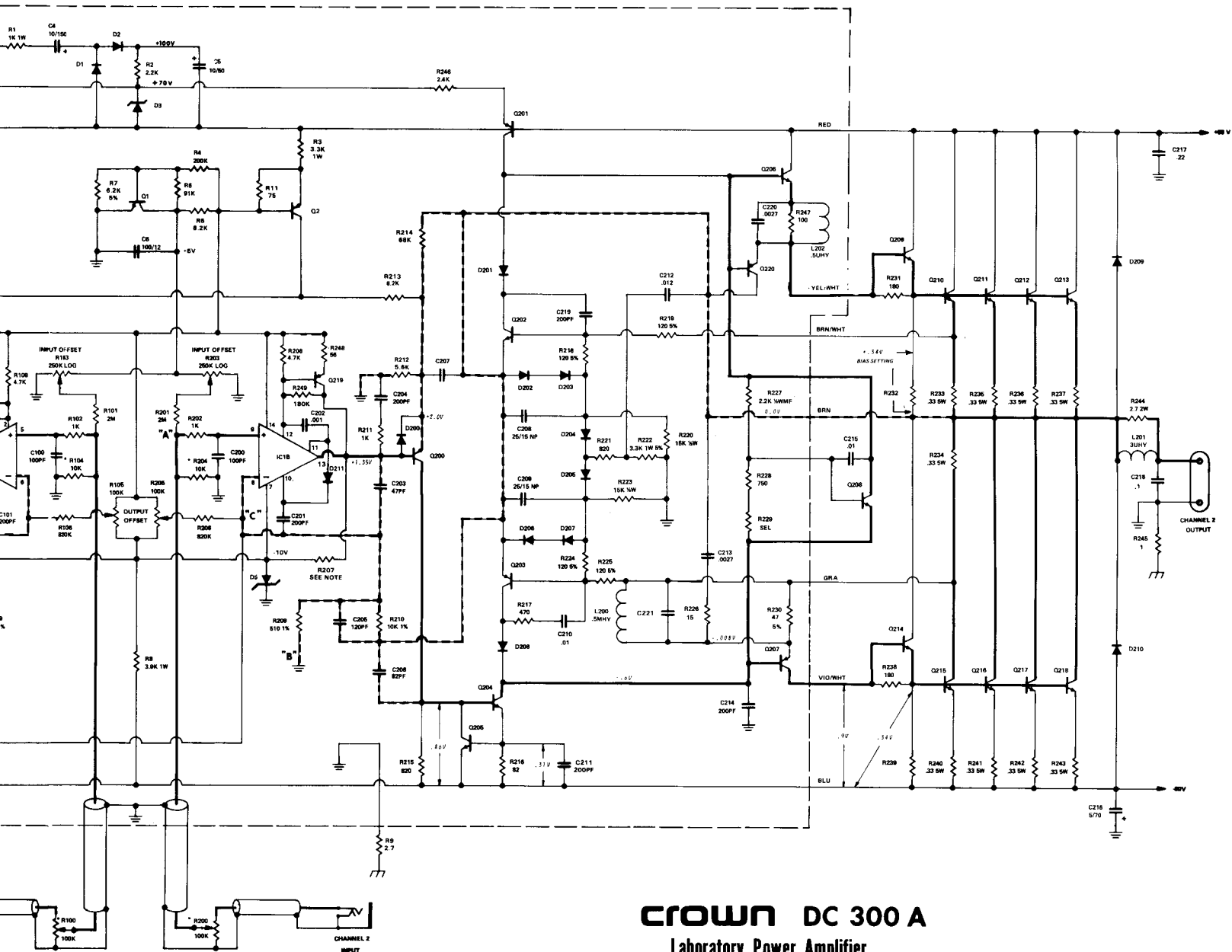

CROWN DC 300 A
Laboratory Power Amplifier

MI-2508

ADDENDUM SHEET TO DC-300A SCHEMATIC (MI-250B)

Refer to the foldout schematic at the rear of the manual. Notice that the power supply is shown wired for 120 VAC, but the two primary windings are not wired identically. The drawing below is a corrected version showing the two 120 V primary windings connected in parallel.

