

# X-1810/D

Reel-To-Reel / Cartridge Combination Stereo Tape Recorder / Deck



BE THE PROUD OWNER OF ONE OF THE WORLD'S BEST PERFORMING TAPE RECORDERS!

This 3-Motor, Automatic Reverse Reel-To-Reel/Cartridge Stereo Tape Recorder features AKAI's famous CROSS-FIELD HEAD (reel-to-reel unit), and a superior ONE-MICRON GAP HEAD (cartridge unit), plus the ability to TRANSFER from reel to cartridge tape.

AKAI's Top Quality All-Purpose combination Reel-To-Reel/Cartridge units are the only ones of their kind in the world . . . . the result of AKAI's "tomorrow's engineering" for "today's enjoyment".

→ Model X-1810D Stereo Tape Deck is also available.

**AKAI**®

MANUFACTURED & DISTRIBUTED BY AKAI ELECTRIC CO., LTD./AKAI TRADING CO., LTD.

# TRANSFER FROM REEL TO CARTRIDGE.....

AKAI's combination Reel-To-Reel/Cartridge tape recording units capable of transferring recorded material from open reel to cartridge tape are the only ones of their kind in the world. The superior engineering required in combining these units into a single tape recorder is sound proof of AKAI's advanced engineering techniques. The versatility of Model X-1810, however, does not detract from the quality. Rather, the superior quality of both units compliment each other for the same AKAI RELIABILITY.

Both the CROSS-FIELD and ONE-MICRON GAP HEADS are AKAI developed and perfected for amazing frequency response and low distortion. Two lever system for dependable and durable operation. Fast Forward Control for cartridge as well as reel-to-reel unit. For Fast Forwarding cartridge tape, simply set Tape Speed Selector to "7-1/2" position. Universal Voltage Selector (100 to 240V AC).

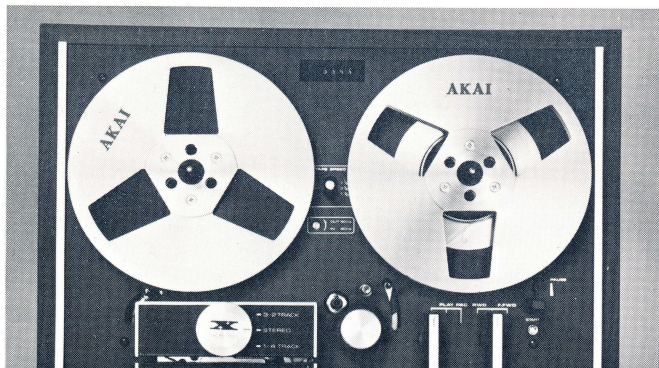

## CROSS-FIELD HEAD

On conventional recorders, the signal and bias are applied to the same recording head. Therefore, the frequencies recorded, especially the high frequency component of the recorded signal, tend to be attenuated or erased by the effect of the bias field. On AKAI's exclusive CROSS-FIELD HEAD, the signal and bias heads are mounted separately in opposition with each other and with their centers slightly off. As the recorded signal is entirely unaffected by the prevailing effect of the bias field, the tape can be recorded over the entire frequency spectrum with maximum fidelity.

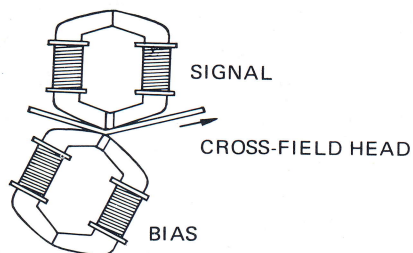

## MOTORS

The X-1810 employs a 3-motor system. A hysteresis synchronous 3-speed motor for capstan drive also serves the cartridge unit. In addition to this highly capable capstan motor, two 6-pole outer-rotor motors are provided for supply and take-up reel drive. This individual motor system ensures tape speed stability and decreased wow and flutter.

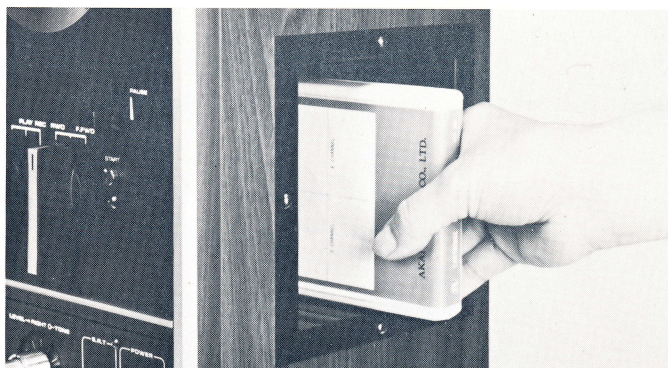
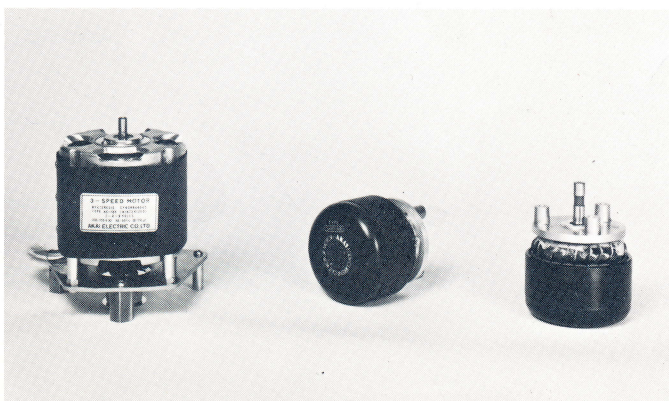

## AUTOMATIC REVERSE

For continuous playback in both directions, simply apply a piece of sensing tape at desired reversing points. When the foil comes in contact with the sensing pins, reverse is effected. Manual Reverse Buttons are also provided for your convenience.

## REEL-TO-REEL AUTOMATIC STOP/SHUT-OFF

One of the unique features of this model is the automatic stop/shut-off function of the unit. If the Shut-Off Switch is at "OFF" position, when the tape comes to the end or is accidentally broken, the Automatic Shut-Off Lever drops and reel movement is stopped. If set to "ON" position, when the Shut-Off Lever drops, the power of the entire unit is cut off.

## CARTRIDGE AUTOMATIC STOP/CONTINUOUS PLAY

The cartridge unit is equipped with an "Automatic Stop" and "Continuous Play" Switch. At playback mode, when the switch is set to "Auto Stop", at the end of program 4, the tape will return to program 1 position and stop automatically. When set to "Cont. Play", the tape will play over and over until the unit is turned off.

## MODE SELECTOR/CHANNEL SELECTOR

The front panel is equipped with a handy Mode Selector for easy selection of Reel, Cartridge, or Transfer operation. Cartridge Channel Indicator Lamps show which program is being played or recorded. Also equipped with a Channel Selector Button for simple and instantaneous program selection.

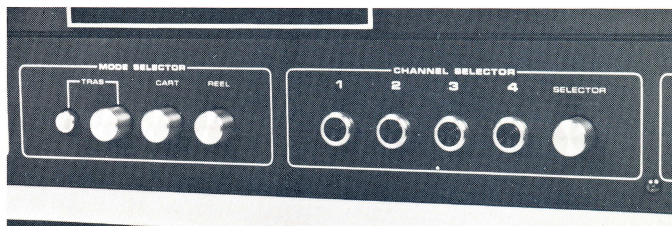

## PAUSE CONTROL (Reel-To-Reel)

Instant Pause Control is useful in editing tape. Simply lift Pause Lever when certain portions of a program are not desired. Also permits adjustment and balance of optimum recording level when recorder is set to recording mode. Handy Start Button for pause lever release.

and many other exciting features to double your pleasure!

### VU METERS

Twin-type VU Meters centrally positioned for easier operation. VU Meter Scales equipped with indicator lamps for easy determination of recording and playback levels.

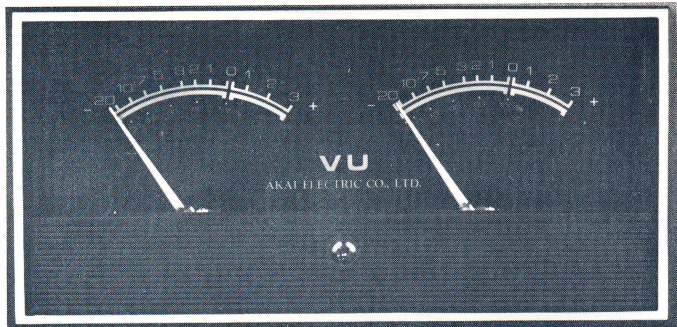

### INDEX COUNTER

4-digit Index Counter with Reset Button for easy indexing. Provides a convenient reference for locating positions on the tape.

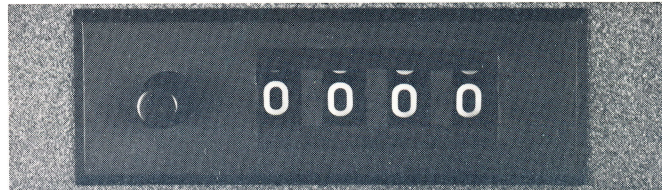

### REMOTE CONTROL

Cartridge Program Selector can be remote controlled with AKAI Remote Control Unit ARC-18. Plugs into remote control socket at rear of recorder.

### S.R.T. BUTTON

For utilization when employing AKAI's new Super Range Tape. This is a newly developed low noise tape and is highly recommended for super performance and a wider frequency range. Also utilize when using other make low noise tapes.

### SYMMETRICALLY DESIGNED CONTROL PANEL

Special attention was given to panel design. The ultra-modern design is not only attractive, but adds to operating ease and convenience. All controls are easy to see and simple to operate.

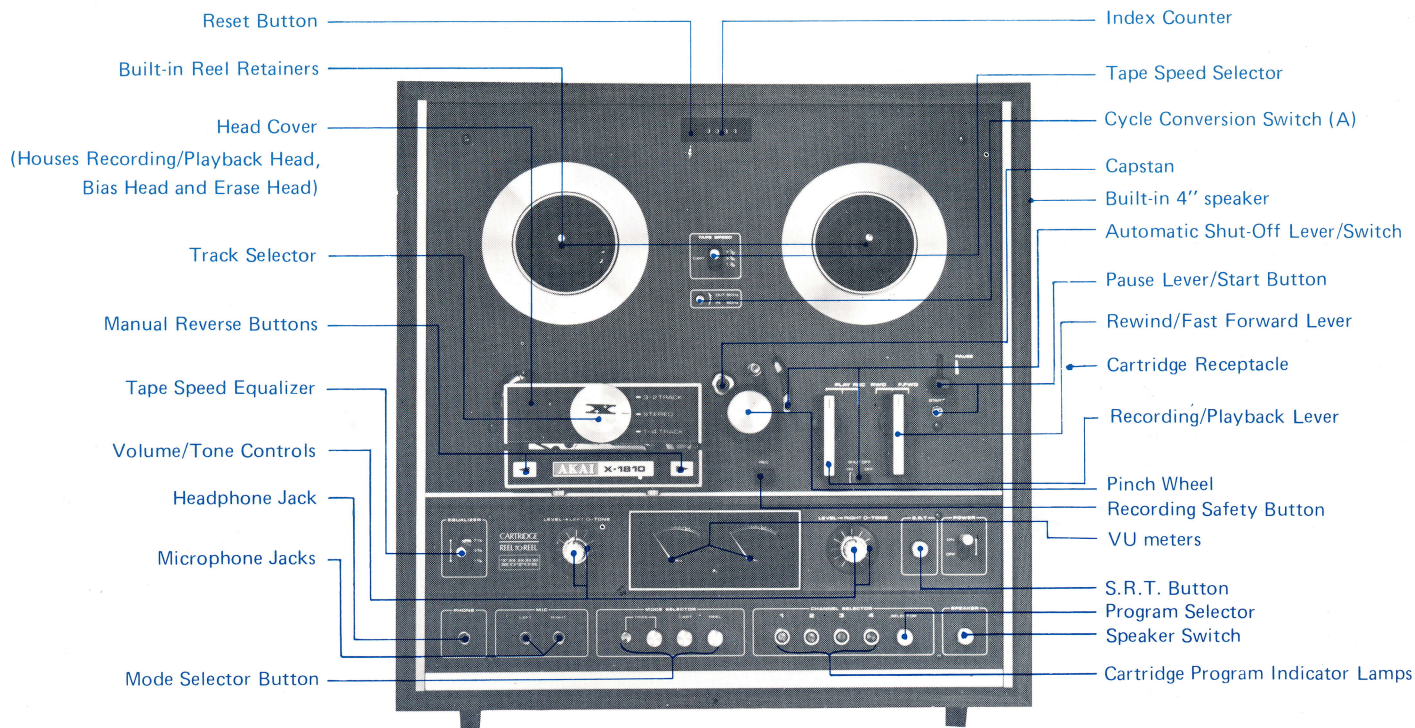



### MODEL X-1810D TAPE DECK

Model X-1810D Tape Deck is also available. The same materials and features are incorporated in this top quality tape deck as in the X-1810 Tape Recorder. For the ultimate in reel-to-reel and cartridge recording/playback, connect this model with AKAI Model AA-6600 Stereo Tuner Amplifier and a pair of Model SW-175 High Fidelity Speakers.

### STANDARD ACCESSORIES

#### Model X-1810 Tape Recorder

ADM-14 Dynamic Microphone w/stand	2
DC1730 Plastic Dust Cover	1
ATR-7M Empty Metallic Reel	1
7" Demonstration Tape	1
ACT-200 Cartridge Tape	1
ST-20 Sensing Tape	1
Spare Fuse	2
Operator's Manual	1

#### Model X-1810D Tape Deck

DC1730 Plastic Dust Cover	1
ATR-7M Empty Metallic Reel	1
ACT-200 Cartridge Tape	1
DR-111 DIN-RCA Connection Cord	1
ST-20 Sensing Tape	1
Spare Fuse	2
Operator's Manual	1

### SPECIFICATIONS (X-1810/X-1810D)

Track System	Reel: 4-Track, 2-Channel Stereo Cartridge: 8-Track, 2-Channel Stereo
Maximum Reel Capacity	7" Reel
Tape Speed	Reel: 7-1/2, 3-3/4 and 1-7/8 ips ( $\pm 0.8\%$ ) Cartridge: 3-3/4 ips
Wow and Flutter	Reel: Less than 0.08% RMS at 7-1/2 ips Less than 0.12% RMS at 3-3/4 ips Less than 0.20% RMS at 1-7/8 ips Cartridge: Less than 0.25% RMS
Equalization	Correct equalization for playback of tapes recorded to the NAB curve.
Frequency Response	Reel: 30 to 22,000 Hz. ( $\pm 3$ dB) at 7-1/2 ips 30 to 18,000 Hz. ( $\pm 3$ dB) at 3-3/4 ips 30 to 9,000 Hz. ( $\pm 3$ dB) at 1-7/8 ips Cartridge: 50 to 16,000 Hz. ( $\pm 3$ dB)
Distortion	Less than 2% (1,000 Hz "0" VU)
Output Power	Total music power 12W (6W/6W) at 8 $\Omega$ (X-1810 only) Continuous power 10W (5W/5W) at 8 $\Omega$ (X-1810 only)
Signal to Noise Ratio	Reel: Better than 50 dB Cartridge: Better than 45 dB
Erase Ratio	Better than 70 dB
Bias Frequency	65 kHz
Heads	Reel: 3 Heads (4-Track 2-Channel Record/Playback, 4-Track Erase, and Bias Heads) Cartridge: 2 Heads (8-Track 2-Channel Record/Playback, and Erase Heads)

Motors	3 Motors (One hysteresis synchronous 3-speed motor for capstan drive and two 6-pole eddy-current outer-rotor motors for supply and take-up reel drive)
Fast Forward & Rewind Time	Reel: 60/75 seconds using a 1,200 ft. tape at 60/50 Hz Cartridge: 230 seconds using a 300 ft. cartridge tape
Recording Capacity	Reel: 8 hrs. monaural recording at 1-7/8 ips using a 1,200 ft. tape. 4 hrs. stereo recording at 1-7/8 ips using a 1,200 ft. tape. Cartridge: 1 hr. stereo recording using a 300 ft. cartridge tape.
Output Jacks	Line (2): 1.23V ("0" VU)/100 $\Omega$ (Required load impedance more than 20 k $\Omega$ ) Headphone (1): 150 mV/8 $\Omega$ Speaker (2): 6W/8 $\Omega$ (X-1810 only)
Input Jacks	Microphone (2): 0.5 mV/100 k $\Omega$ Line (2): 60 mV/150 k $\Omega$
DIN Jack	1.23V/20 mV
Speaker	Two 4" speakers (X-1810 only)
Semi-Conductors	Transistors: 25 (X-1810D: 17) Diodes: 17 (X-1810D: 15)
Power Source	100 to 240V AC, 50/60 Hz.
Power Consumption	110W (X-1810D: 95W)
Dimensions	17.4(W) x 18(H) x 9.6" (435 x 450 x 240 mm)
Weight	47 lbs. (21.4 kg.) (X-1810D: 20 kg.)

### OPTIONAL ACCESSORIES

<p>UM-101</p>  <p>Non-Directional Dynamic Microphone</p>	<p>ARC-18</p>  <p>Remote Control (Cartridge)</p>	<p>ACT-200/ACT-300</p>  <p>Cartridge Tape</p>	<p>HC-500</p>  <p>Head Cleaning Kit (Reel-To-Reel)</p>	<p>CHC-400</p>  <p>Head Cleaner (Cartridge)</p>
---	---	--	--	--

AKAI Stereo Tuner Amplifiers and High Fidelity Speaker Systems are designed to match and enhance the performance of AKAI Tape Recorders and Decks. For free information, kindly inquire at your nearest AKAI dealer or write directly to AKAI CO., LTD., Tokyo, Japan.

The AKAI policy is one of continual development and improvement. For that reason, AKAI reserves the right to change specifications without notice, and without incurring any obligation relating to models previously manufactured by them.

MANUFACTURED & DISTRIBUTED BY  
AKAI ELECTRIC CO., LTD.  
AKAI TRADING CO., LTD.

12-14, 2-chome, Higashi-Kojiya,  
Ohta-ku, Tokyo, Japan