

Detail 2F

- ( ) Referring to Detail 2F, prepare a 13" length of 3-conductor cable.
- ( ) At the end of the cable with no shield pigtail, connect the red wire to double-lug 1 of switch FE (NS).
- ( ) Connect the white wire to double-lug 12 of switch FE (NS).
- ( ) Connect the black lead to double-lug 11 of switch FE (NS).
- ( ) Again referring to Detail 2F, prepare an 11" length of 3-conductor cable.
- ( ) At the end of this cable having no shield pigtail, connect the black lead to double-lug 5 of switch FE (NS).
- ( ) Connect the white lead to double-lug 6 of switch FE (NS).
- ( ) Connect the red lead to double-lug 7 of switch FE (NS).

Refer to Pictorial 3 for the following steps.

- ( ) Locate the remaining prepared P.E.C. network (#84-23). Place sleeving on each lead and position the network between controls FB and FC next to the previously installed P.E.C. network. Connect the leads as follows:

<u>LEAD NO.</u>	<u>CONNECT TO</u>
( ) 1	lug 2 of terminal strip Y (S-2)
( ) 2	lug 6 of control FC (S-1)
( ) 3	lug 6 of control FB (S-1)
( ) 4	lug 5 of control FC (S-1)
( ) 5	lug 4 of control FC (S-1)
( ) 6	lug 5 of control FB (S-2)
( ) 7	lug 4 of control FB (S-1)
( ) 8	lug 1 of terminal strip Y (S-3)

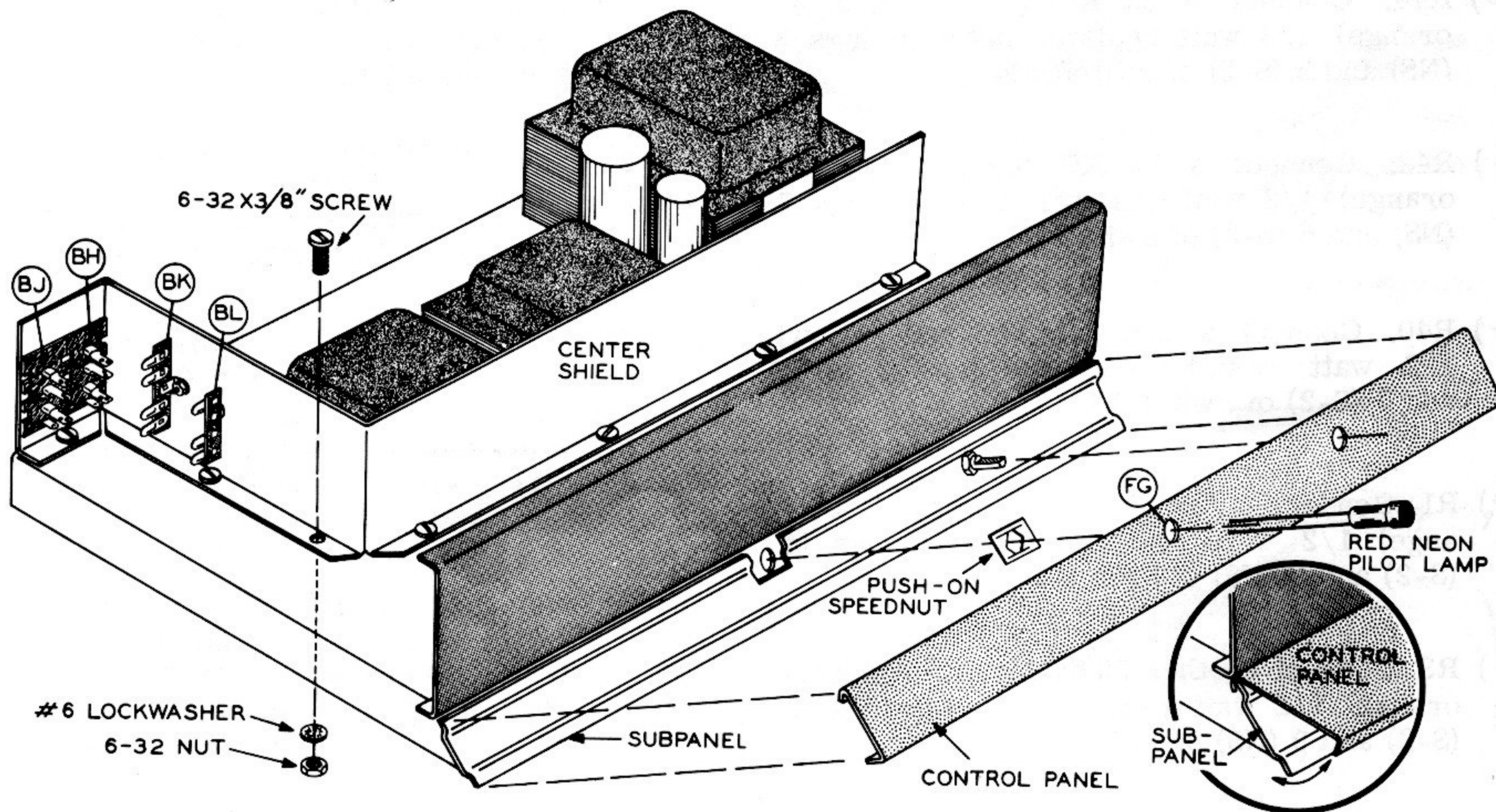

Pictorial 4

Refer to Pictorial 4 for the following steps.

- ( ) Locate the center shield and mount a triple phono socket with an insulator at location BH on the center shield. Use 6-32 x 3/8" screws, #6 lockwashers and 6-32 nuts. Refer to Detail 4A for proper orientation of the phono socket.
- ( ) Similarly mount a triple phono socket and insulator at location BJ. Use 6-32 x 3/8" screws, #6 lockwashers and 6-32 nuts.
- ( ) Mount a 4-lug terminal strip at location BK on the center shield. Use #6 hardware.
- ( ) Mount a 3-lug terminal strip at location BL on the center shield. Use #6 hardware.
- ( ) Mount the center shield to the top of the main chassis. Use 6-32 x 3/8" screws, #6 lockwashers, and 6-32 nuts.

Refer to Detail 4A for the following steps.

- ( ) Connect a 2" length of hookup wire between lugs 2 (S-1) and 5 (NS) of phono socket BH.

- ( ) Connect a 1-1/2" length of hookup wire from lug 5 of phono socket BH (NS) to lug 5 of phono socket BJ (NS).
- ( ) Connect another 1-1/2" length of hookup wire from lug 5 of phono socket BH (S-3) to lug 4 of terminal strip BK (NS).
- ( ) Connect one end of an 8" length of hookup wire to lug 4 of terminal strip BK (NS). Place the free end of this wire through hole HQ in the chassis. It will be connected later.

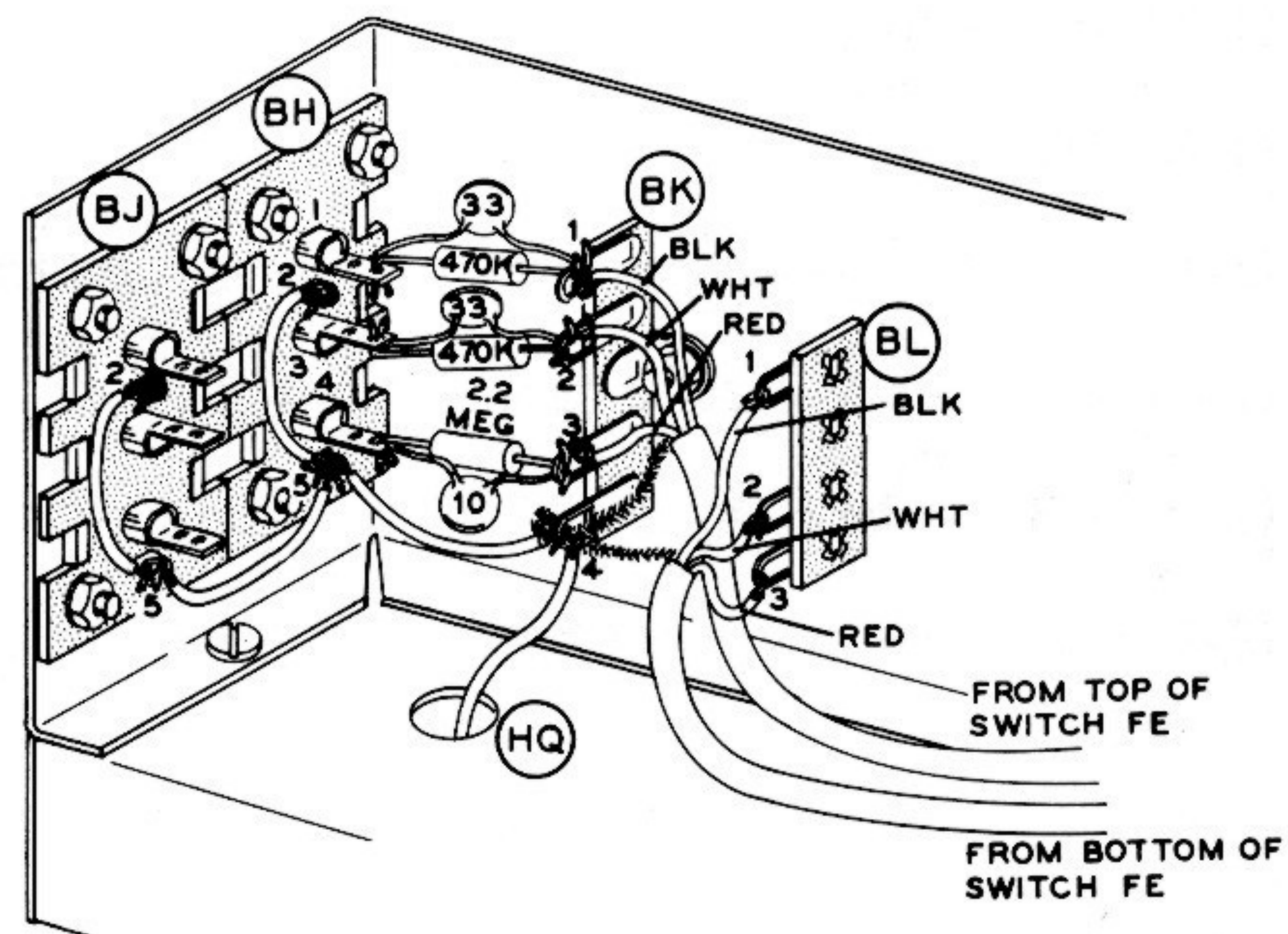

Detail 4A

- ( ) Connect a 2" length of hookup wire between lugs 2 (S-1) and 5 (S-2) of phono socket BJ.
- ( ) Dress the length of 3-conductor cable coming from the top of switch FE as shown in Detail 4A and Pictorial 2. Connect the black lead of this cable to lug 1 of terminal strip BK (NS).
- ( ) Connect the white lead to lug 2 of terminal strip BK (NS).
- ( ) Connect the red lead to lug 3 of terminal strip BK (NS).
- ( ) Connect the shield pigtail of this cable to lug 4 of terminal strip BK (NS).
- ( ) Dress the remaining 3-conductor cable as shown in Detail 4A and Pictorial 2.
- ( ) Connect the black lead of this cable to lug 1 of terminal strip BL (NS).
- ( ) Connect the white lead to lug 2 of terminal strip BL (NS).
- ( ) Connect the red lead to lug 3 of terminal strip BL (NS).
- ( ) Connect the shield pigtail to lug 4 of terminal strip BK (S-4).
- ( ) R6. Connect a 2.2 megohm (red-red-green) 1/2 watt resistor from lug 4 of phono socket BH (NS) to lug 3 of terminal strip BK (NS).
- ( ) C1. Connect a 10  $\mu\mu\text{f}$  disc ceramic capacitor from lug 4 of phono socket BH (S-2) to lug 3 of terminal strip BK (S-3).
- ( ) R4. Connect a 470 K $\Omega$  (yellow-violet-yellow) 1/2 watt resistor from lug 3 of phono socket BH (NS) to lug 2 of terminal strip BK (NS).
- ( ) C9. Connect a 33  $\mu\mu\text{f}$  disc ceramic capacitor from lug 3 of phono socket BH (S-2) to lug 2 of terminal strip BK (S-3).
- ( ) R2. Connect a 470 K $\Omega$  (yellow-violet-yellow) 1/2 watt resistor from lug 1 of phono socket BH (NS) to lug 1 of terminal strip BK (NS).

- ( ) C7. Connect a 33  $\mu\mu\text{f}$  disc ceramic capacitor from lug 1 of phono socket BH (S-2) to lug 1 of terminal strip BK (S-3).

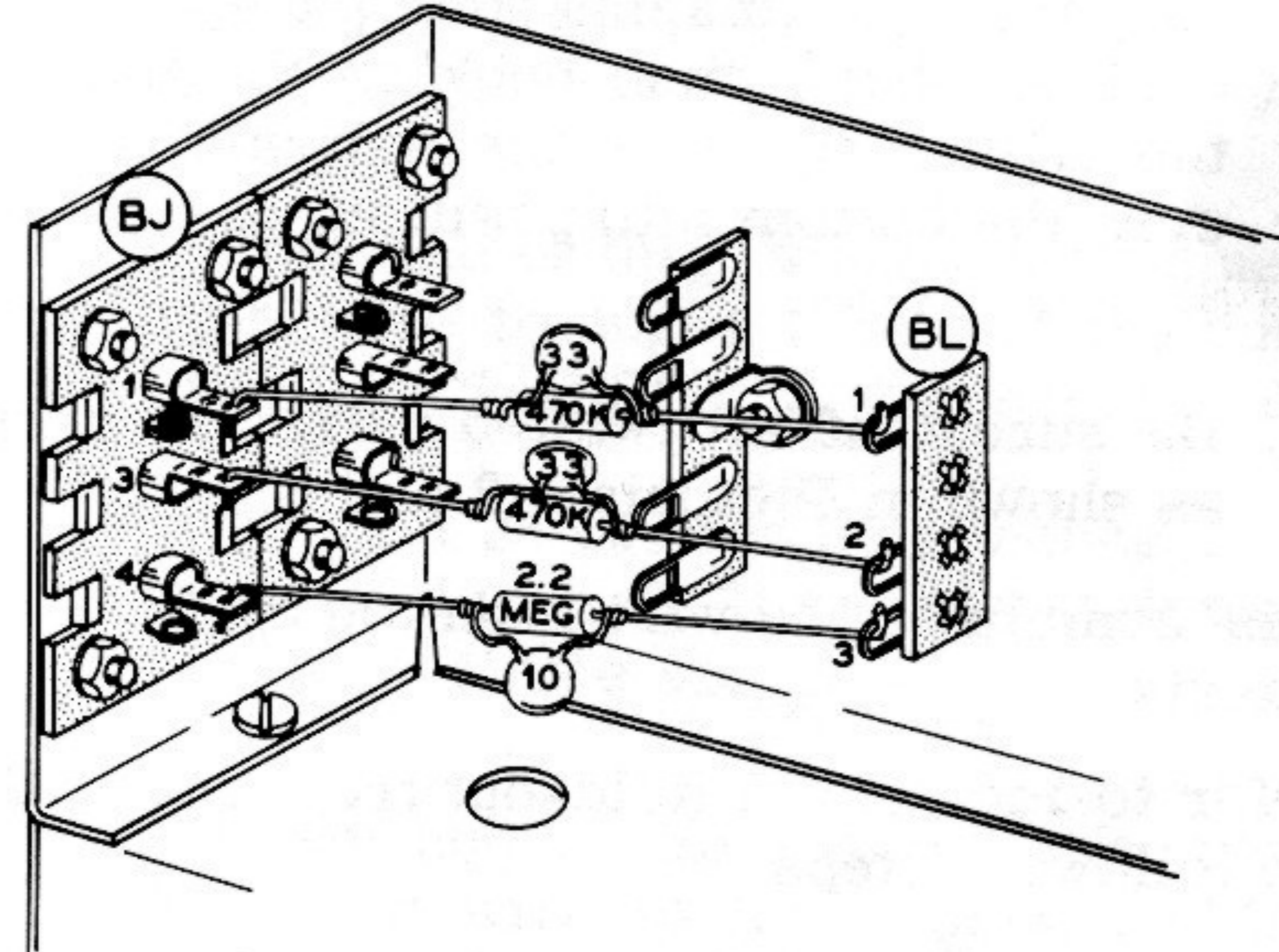

Detail 4B

Refer to Detail 4B for the following steps.

- ( ) R39, C27. Referring to Detail 4C, prepare a 2.2 megohm (red-red-green) 1/2 watt resistor and 10  $\mu\mu\text{f}$  disc ceramic capacitor combination.

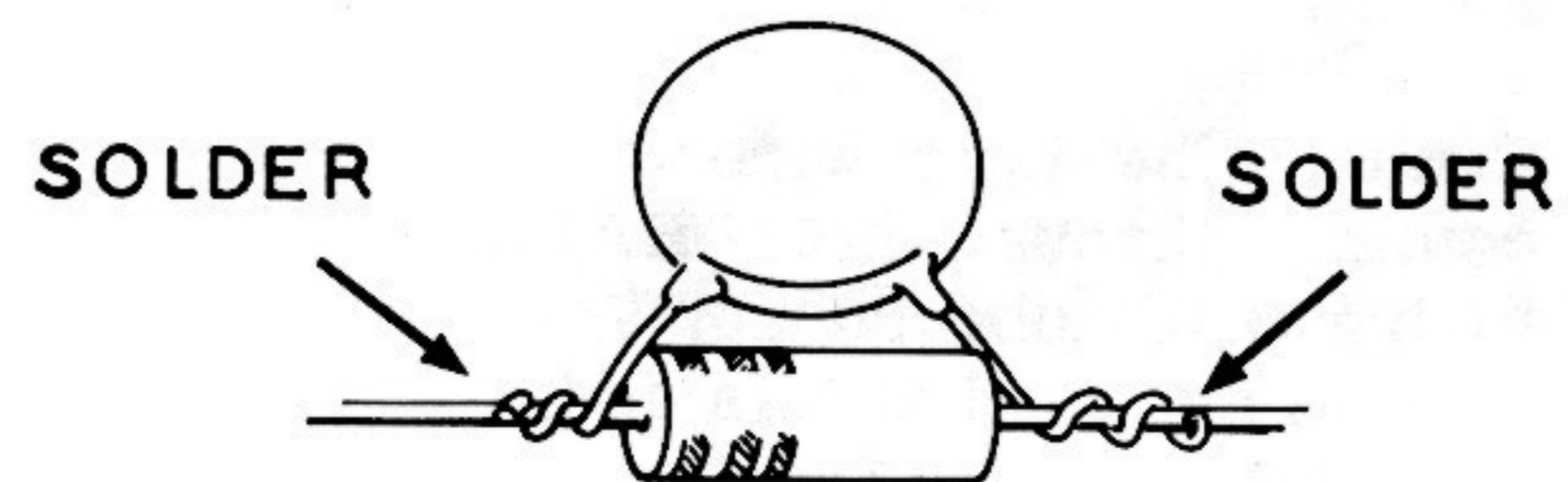

Detail 4C

- ( ) Connect this resistor-capacitor combination from lug 4 of phono socket BJ (S-1) to lug 3 of terminal strip BL (S-2).
- ( ) R41, C34. Prepare another 470 K $\Omega$  (yellow-violet-yellow) 1/2 watt resistor and 33  $\mu\mu\text{f}$  disc ceramic capacitor combination.
- ( ) Connect this combination from lug 3 of phono socket BJ (S-1) to lug 2 of terminal strip BL (S-2).
- ( ) R43, C32. Prepare a 470 K $\Omega$  (yellow-violet-yellow) 1/2 watt resistor and 33  $\mu\mu\text{f}$  disc ceramic capacitor combination.
- ( ) Connect this resistor-capacitor combination from lug 1 of phono socket BJ (S-1) to lug 1 of terminal strip BL (S-2).

- ( ) Locate the control panel trim strip and mount the red neon pilot lamp at FG. Use the push-on speednut. See Pictorial 4.
- ( ) Install the control panel trim strip on the subpanel by placing the panel over the control shaft, then hooking the top lip of the trim strip over the subpanel and forcing the bottom into position. See Pictorial 4.
- ( ) Be sure that all twisted pairs are dressed as shown in Pictorials 2 and 3.

This completes the wiring on top of the AA-151 chassis.

Refer to Pictorial 5 (fold-out from Page 16) for the following steps.

- ( ) Connect the free end of the hookup wire coming through hole HQ in the chassis to lug 1 of terminal strip T (S-1).
- ( ) Connect the light wire of the twisted pair coming through hole HB in the chassis to lug 8 of tube socket V5 (S-1). Connect the dark wire to lug 4 of terminal strip P (NS).
- ( ) Connect the light wire of the twisted pair coming through hole HA in the chassis to lug 8 of tube socket V6 (S-1). The dark wire is not used at this end.
- ( ) Connect the free end of the wire extending through hole HA to lug 4 of terminal strip P (NS).
- ( ) Connect the free end of the capacitor lead coming through hole HC in the chassis to lug 5 of tube socket V4 (NS). Be sure that the sleeving is on the lead.
- ( ) Connect the free end of the capacitor lead extending through hole HD in the chassis to lug 5 of tube socket V3 (NS). Be sure that the sleeving is on the lead.
- ( ) Connect the light wire from the twisted pair extending through hole HF in the chassis to lug 1 of tube socket V4 (S-1). The dark wire is not used at this end.
- ( ) Connect the light wire of the twisted pair extending through hole HE in the chassis to lug 1 of tube socket V3 (S-1). The dark wire is not used at this end.
- ( ) Connect the free end of the capacitor lead extending through hole HG in the chassis to lug 8 of tube socket V2 (NS). Be sure that the sleeving is on the lead.
- ( ) Connect the free end of the capacitor lead extending through hole HM in the chassis to lug 8 of tube socket V1 (NS). Use sleeving.
- ( ) Connect the dark wire of the twisted pair extending through hole HH in the chassis to the bus wire (S-1). Cut the light wire to length and connect it to lug 2 of terminal strip W (NS).
- ( ) Connect the dark wire of the twisted pair extending through hole HJ in the chassis to the bus wire (S-1). Cut the light wire to length and connect it to lug 3 of terminal strip W (NS).
- ( ) Cut the light wire of the twisted pair coming through hole HL in the chassis to length and connect it to lug 2 of terminal strip X (NS). The dark wire is not used.
- ( ) Connect the dark wire of the twisted pair extending through hole HN in the chassis to the bus wire (S-1). Cut the light wire to length and connect it to lug 3 of terminal strip X (NS).
- ( ) Twist the two green power transformer T3 leads together and connect the longest lead to lug 3 of control J (NS). Connect the other green lead to lug 1 of control J (NS).
- ( ) Twist the two blue power transformer leads together and connect the longest lead to lug 3 of control K (NS). Connect the other blue lead to lug 1 of control K (NS).
- ( ) Connect the red-yellow power transformer lead to lug 1 of electrolytic capacitor D (NS).
- ( ) Twist the two yellow power transformer leads together and connect the longest lead to lug 8 of tube socket V11 (NS). Connect the other yellow lead to lug 2 of tube socket V11 (S-1).
- ( ) Twist the two red power transformer leads together and connect the longest lead to lug 6 of tube socket V11 (S-1). Connect the other red lead to lug 4 of V11 (S-1).

- ( ) Connect the shorter black power transformer lead to lug 1 of fuse holder BC (NS). Connect the other black transformer lead to lug 2 of AC socket BB (NS).

NOTE: In the following steps route the twisted wires as shown in Pictorial 5.

- ( ) At one end of a 3-1/2" twisted pair, connect the light wire to lug 4 (NS) and the dark wire to lug 5 (NS) of tube socket V9.
- ( ) At the other end of this twisted pair, connect the light wire to lug 4 (S-1) and the dark wire to lug 5 (S-1) of tube socket V10. Route this wire as shown.
- ( ) At one end of a 7-1/2" twisted pair, connect the light wire to lug 4 (S-2) and the dark wire to lug 5 (S-2) of tube socket V9.
- ( ) At the other end of this twisted pair, connect the light wire to lug 4 (NS) and the dark wire to lug 5 (NS) of tube socket V5.
- ( ) At one end of a 3-1/2" twisted pair, connect the light wire to lug 4 (NS) and the dark wire to lug 5 (NS) of tube socket V7.
- ( ) At the other end of this twisted pair, connect the light wire to lug 4 (S-1) and the dark wire to lug 5 (S-1) of tube socket V8.
- ( ) At one end of a 12" twisted pair, connect the light wire to lug 4 (S-2) and the dark wire to lug 5 (S-2) of tube socket V7.
- ( ) At the other end of this twisted pair, connect the light wire to lug 5 (NS) and the dark wire to lug 4 (NS) of tube socket V6.
- ( ) At one end of a 9-1/2" twisted pair, connect the light wire to lug 1 (S-1) and the dark wire to lug 2 (S-1) of tube socket V1.
- ( ) At the other end of this twisted pair, connect the light wire to lug 3 (NS) and the dark wire to lug 4 (NS) of tube socket V3.
- ( ) At one end of a 5" twisted pair, connect the light wire to lug 1 (S-1) and the dark wire to lug 2 (S-1) of tube socket V2.
- ( ) At the other end of this twisted pair, connect the light wire to lug 3 (NS) and the dark wire to lug 4 (NS) of tube socket V4.
- ( ) At one end of a 7-1/2" twisted pair, connect the light wire to lug 3 (S-2) and the dark wire to lug 4 (S-2) of tube socket V4.
- ( ) At the other end of this twisted pair connect the light wire to lug 4 (NS) and the dark wire to lug 5 (NS) of tube socket V5.
- ( ) At one end of a 3" twisted pair connect the light wire to lug 4 (S-3) and the dark wire to lug 5 (S-3) of tube socket V5.
- ( ) At the other end of this twisted pair, connect the light wire to lug 1 (S-2) and the dark wire to lug 3 (S-2) of control K.
- ( ) At one end of a 9" twisted pair, connect the light wire to lug 3 (S-2) and the dark wire to lug 4 (S-2) of tube socket V3.
- ( ) At the other end of this twisted pair, connect the light wire to lug 5 (NS) and the dark wire to lug 4 (NS) of tube socket V6.
- ( ) At one end of a 5-1/2" twisted pair, connect the light wire to lug 5 (S-3) and the dark wire to lug 4 (S-3) of tube socket V6.
- ( ) At the other end of this twisted pair, connect the light wire to lug 1 (S-2) and the dark wire to lug 3 (S-2) of control J.
- ( ) At one end of an 8" twisted pair, connect the light wire to lug 1 (NS) and the dark wire to lug 2 (NS) of terminal strip U.
- ( ) At the other end of this twisted pair, connect the light wire to lug 1 (NS) and the dark wire to lug 2 (NS) of terminal strip N.
- ( ) Connect either of the pilot lamp leads to lug 1 (S-2) and the other pilot lamp lead to lug 2 (S-2) of terminal strip U. Use sleeving on each lead.
- ( ) At one end of a 14" twisted pair, cut the light wire to length and connect it to lug 1 (S-2) and the dark wire to lug 3 (NS) of terminal strip N.

- ( ) At the other end of this twisted pair, connect the light wire to lug 1 of AC socket BA (NS). Connect the dark wire to lug 1 of fuse holder BC (S-2).
- ( ) At one end of a 14-1/2" twisted pair, connect the light wire to lug 1 (S-1) and the dark wire to lug 2 (S-1) of switch FF.
- ( ) At the other end of this twisted pair, connect the light wire to lug 2 (NS) of AC socket BA and the dark wire to lug 1 (NS) of AC socket BB.
- ( ) Connect the brown lead from output transformer T2 to lug 1 of screw-type terminal strip BD (S-1).
- ( ) Connect the orange lead from output transformer T2 to lug 2 of terminal strip BD (S-1).
- ( ) Connect the yellow lead from output transformer T2 to lug 3 of terminal strip BD (NS).
- ( ) Connect the black lead from output transformer T2 to lug 1 of terminal strip A (NS).
- ( ) Connect the brown lead from output transformer T1 to lug 2 of screw-type terminal strip BF (S-1).
- ( ) Connect the orange lead from output transformer T1 to lug 3 of terminal strip BF (S-1).
- ( ) Connect the yellow lead from output transformer T1 to lug 4 of terminal strip BF (NS).
- ( ) Connect the black lead from output transformer T1 to lug 1 of terminal strip B (NS).
- ( ) At one end of a 13" twisted pair, connect the light wire to lug 2 of tube socket V9 (NS). Connect the dark wire to lug 1 of terminal strip A (NS).
- ( ) At the other end of this twisted pair, connect the light wire to lug 2 of terminal strip L (NS). The dark wire is not used at this end.
- ( ) At one end of a 14" twisted pair, connect the light wire to lug 2 of tube socket V10 (NS). Connect the dark wire to lug 2 of terminal strip A (NS).
- ( ) At the other end of this twisted pair, connect the light wire to lug 1 of terminal strip L (NS). The dark wire is not used at this end.
- ( ) At one end of a 16-1/2" twisted pair, connect the light wire to lug 2 of tube socket V7 (NS). Connect the dark wire to lug 1 of terminal strip B (NS).
- ( ) At the other end of this twisted pair, connect the light wire to lug 4 of terminal strip L (NS). The dark wire is not used at this end.
- ( ) At one end of an 18-1/2" twisted pair, connect the light wire to lug 2 of tube socket V8 (NS). Connect the dark wire to lug 2 of terminal strip B (NS).
- ( ) At the other end of this twisted pair, connect the light wire to lug 3 of terminal strip L (NS). The dark wire is not used at this end.
- ( ) Connect the blue lead of output transformer T1 to lug 2 of terminal strip H (NS).
- ( ) Connect the green lead of output transformer T1 to lug 1 of terminal strip H (NS).
- ( ) Connect the green-yellow lead of output transformer T1 to lug 1 of terminal strip G (NS).
- ( ) Connect the blue-yellow lead of output transformer T1 to lug 2 of terminal strip G (NS).
- ( ) Connect the red lead of output transformer T1 to lug 1 of terminal strip F (NS).
- ( ) Connect the green lead of output transformer T2 to lug 3 of terminal strip G (NS).
- ( ) Connect the blue lead of output transformer T2 to lug 4 of terminal strip G (NS).

- ( ) Connect the red lead of output transformer T2 to lug 1 of terminal strip F (NS).
  - ( ) Connect the green-yellow lead of output transformer T2 to lug 2 of terminal strip F (NS).
  - ( ) Connect the blue-yellow lead of output transformer T2 to lug 3 of terminal strip F (NS).
- Refer to Pictorial 6 (fold-out from Page 27) for the following steps.
- ( ) Connect a 3-1/2" length of hookup wire from lug 1 of AC socket BA (NS) to lug 2 of AC socket BB (S-2).
  - ( ) Connect a 3-1/2" length of hookup wire from lug 1 of AC socket BB (S-2) to lug 2 of fuse holder BC (NS).
  - ( ) Connect a 4" length of hookup wire from lug 4 of electrolytic capacitor D (S-1) to lug 1 of terminal strip A (NS).
  - ( ) Connect a 2-1/2" length of hookup wire from lug 8 of tube socket V11 (S-2) to lug 2 of electrolytic capacitor D (NS).
  - ( ) Connect a 3" length of hookup wire from lug 2 of electrolytic capacitor D (NS) to lug 1 of terminal strip F (S-3).
  - ( ) Connect a 7" length of hookup wire from lug 1 of electrolytic capacitor D (NS) to lug 1 of terminal strip M (NS).
  - ( ) Connect a 7" length of hookup wire from lug 1 of electrolytic capacitor E (NS) to lug 1 of terminal strip R (NS).
  - ( ) Connect an 8-1/2" length of hookup wire from lug 2 of electrolytic capacitor E (NS) to lug 3 of tube socket V2 (NS).
  - ( ) Connect a 10-1/2" length of hookup wire from lug 3 of electrolytic capacitor E (NS) to the bus wire (S-1). This wire should be connected to the bus wire between tube sockets V1 and V2.
  - ( ) Connect a 4" length of hookup wire from lug 2 of control K (NS) to lug 2 of control J (S-1).
  - ( ) Connect a 7" length of hookup wire from lug 3 of terminal strip F (S-2) to lug 7 of tube socket V9 (S-1). Dress this wire under the output transformer leads.
  - ( ) Connect a 7" length of hookup wire from lug 2 of terminal strip F (S-2) to lug 9 of tube socket V9 (S-1). Dress this wire under the output transformer leads.
  - ( ) Connect a 3" length of hookup wire from lug 3 of tube socket V9 (S-1) to lug 3 of tube socket V10 (NS).
  - ( ) Connect a 4" length of hookup wire from lug 2 of terminal strip A (NS) to lug 1 of terminal strip B (NS).
  - ( ) Connect a 5-1/4" length of hookup wire from lug 2 of terminal strip A (NS) to lug 1 of screw-type terminal strip BF (NS).
  - ( ) Connect a 2-1/4" length of hookup wire from lug 1 of terminal strip BF (S-2) to lug 1 of switch BE (NS).
  - ( ) Connect a 1" length of hookup wire between lugs 1 (S-2) and 6 (S-1) of switch BE.
  - ( ) Connect a 1" length of hookup wire between lugs 3 (S-1) and 4 (NS) of switch BE.
  - ( ) Referring to Pictorial 6, install a #6 spade lug on the end of the heavy black wire.
  - ( ) Place the free end of this wire through hole HR in the chassis and connect it to lug 4 of switch BE (S-2).
  - ( ) Connect a 2" length of hookup wire from lug 2 of switch BE (S-1) to lug 4 of screw-type terminal strip BD (S-1).
  - ( ) Connect a 2" length of hookup wire from lug 5 of switch BE (S-1) to lug 5 of terminal strip BD (S-1).
  - ( ) Connect a 9" length of hookup wire from lug 3 of terminal strip BD (S-2) to lug 1 of terminal strip P (NS).

- ( ) Connect a 6" length of hookup wire from lug 7 of tube socket V10 (S-1) to lug 4 of terminal strip G (S-2).
- ( ) Connect a 5" length of hookup wire from lug 9 of tube socket V10 (S-1) to lug 3 of terminal strip G (S-2).
- ( ) Connect a 2-3/4" length of hookup wire from lug 3 of tube socket V10 (S-2) to lug 3 of tube socket V7 (NS).
- ( ) Connect a 2-3/4" length of hookup wire from lug 3 of tube socket V7 (S-2) to lug 3 of tube socket V8 (NS).
- ( ) Connect a 3" length of hookup wire from lug 3 of tube socket V8 (S-2) to lug 1 of terminal strip C (NS).
- ( ) Connect a 4-1/2" length of hookup wire from lug 7 of tube socket V7 (S-1) to lug 2 of terminal strip G (S-2).
- ( ) Connect a 4-1/2" length of hookup wire from lug 9 of tube socket V7 (S-1) to lug 1 of terminal strip G (S-2).
- ( ) Connect a 15" length of hookup wire from lug 4 of terminal strip BF (S-2) to lug 1 of terminal strip Q (NS).
- ( ) Connect a 5-1/2" length of hookup wire from lug 2 of terminal strip B (NS) to lug 3 of terminal strip H (NS).
- ( ) Connect a 5-1/2" length of hookup wire from lug 7 of tube socket V8 (S-1) to lug 2 of terminal strip H (S-2).
- ( ) Connect a 5" length of hookup wire from lug 9 of tube socket V8 (S-1) to lug 1 of terminal strip H (S-2).
- ( ) Connect a 3-1/2" length of hookup wire from lug 3 of tube socket V1 (NS) to lug 3 of tube socket V2 (NS).
- ( ) Connect a 1-1/2" length of hookup wire between lugs 1 (NS) and 2 (NS) of terminal strip R.
- ( ) Connect a 3" length of hookup wire from lug 3 of terminal strip P (NS) to lug 3 of terminal strip Q (NS).
- ( ) Connect a 3-1/2" length of hookup wire from lug 2 of terminal strip P (NS) to lug 9 of tube socket V5 (S-1).
- ( ) Connect a 5-1/2" length of hookup wire from lug 4 of terminal strip P (NS) to lug 1 of terminal strip M (NS).
- ( ) Connect a 2-1/2" length of hookup wire from lug 2 of terminal strip Q (NS) to lug 9 of tube socket V6 (S-1).
- ( ) Connect a 6" length of hookup wire from lug 5  $\Delta$  of electrolytic capacitor D (NS) to lug 3 of terminal strip P (NS).



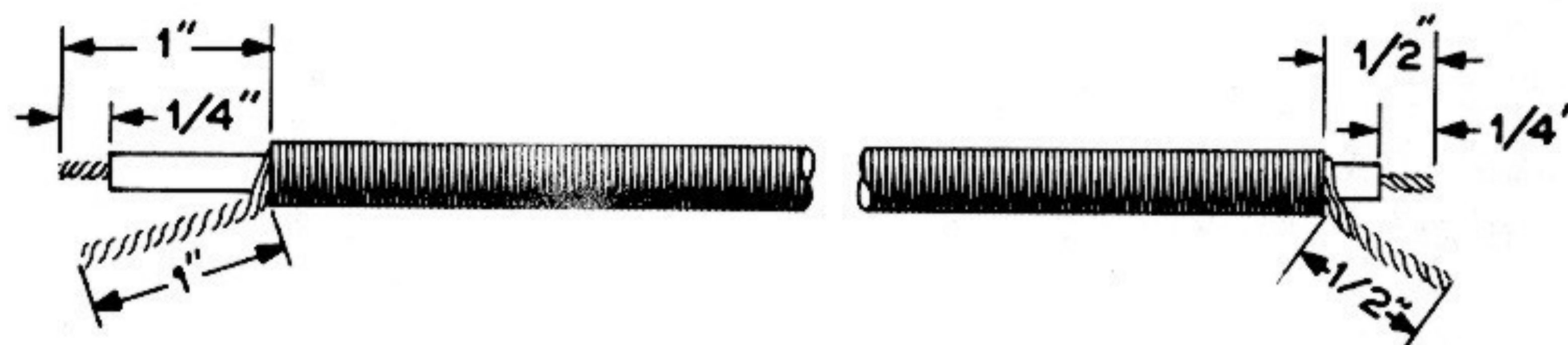
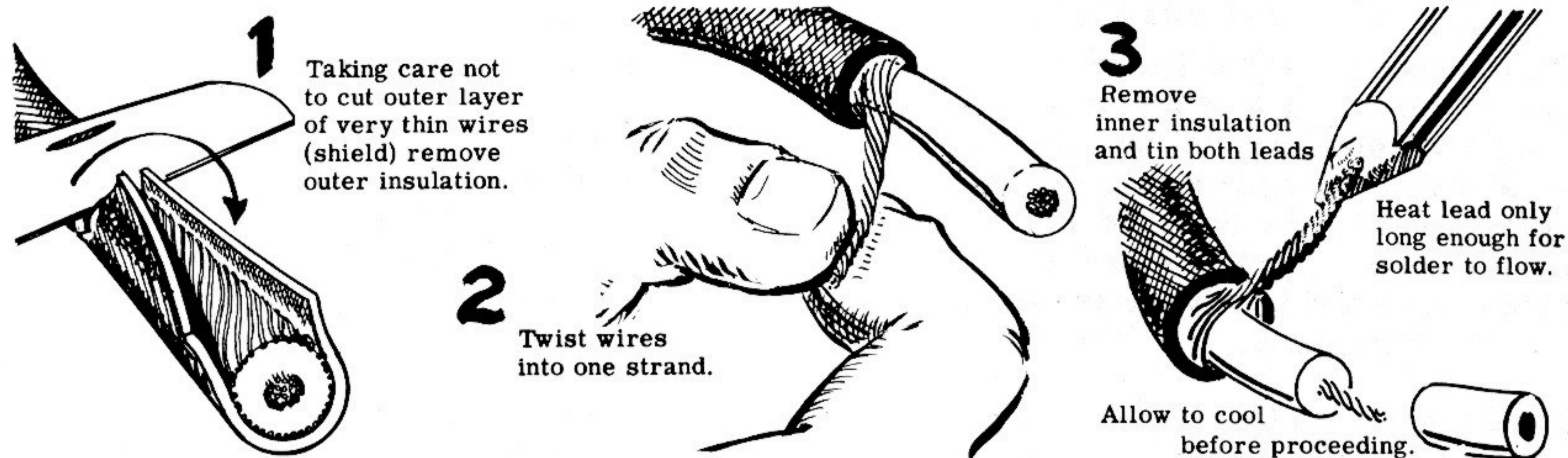

Detail 6A

- ( ) Referring to Detail 6A, prepare a 10" length of shielded audio cable.
- ( ) At the 1/2" prepared end of the shielded audio cable, connect the shield pigtail to lug 4 of phono socket BG (NS). Connect the inner wire to lug 3 of phono socket BG (NS). Pass the free end of this audio cable through hole HQ in the chassis.
- ( ) Dress the above audio cable along the top of the chassis and place it through the hole in the chassis nearest to tube socket V2.
- ( ) Connect the shield pigtail at this end of the audio cable to the bus wire (S-1). Connect the inner wire to lug 5 of tube socket V2 (S-1).
- ( ) Referring to Detail 6A, prepare a 9" length of shielded audio cable.
- ( ) At the 1/2" prepared end of this cable, connect the shield pigtail to lug 1 of phono socket BG (NS). Connect the inner wire to lug 2 of BG (NS). Place the free end of this audio cable through hole HQ in the chassis.
- ( ) Dress this audio cable along the top of the chassis and place it through the hole in the chassis nearest tube socket V1.
- ( ) Connect the shield pigtail at this end of the cable to the bus wire (S-1). Connect the inner wire to lug 5 of tube socket V1 (S-1).

Refer to Pictorial 7 for the following steps.

- ( ) C47. Connect a .01  $\mu$ fd 1.6 kv disc ceramic capacitor from lug 2 of fuse holder BC (S-2) to lug 1 of electrolytic capacitor D (S-3). Use sleeving on both leads. (Apply enough solder and heat to lug 1 of D to melt the solder onto the mounting wafer. Use sleeving on both leads and position this capacitor as shown in Pictorial 7.
- ( ) R36. Connect a 4700  $\Omega$  (yellow-violet-red) 2 watt resistor between lugs 2  $\blacktriangle$  (S-3) and 5  $\blacktriangle$  (NS) of electrolytic capacitor D.
- ( ) R25. Connect a 1000  $\Omega$  (brown-black-red) 1 watt resistor from lug 5  $\blacktriangle$  of electrolytic capacitor D (S-3) to lug 1  $\blacksquare$  of electrolytic capacitor E (NS).
- ( ) R34. Connect a 22 K $\Omega$  (red-red-orange) 1/2 watt resistor between lugs 1  $\blacksquare$  (S-3) and 2  $\blacktriangle$  (NS) of electrolytic capacitor E.
- ( ) R70. Connect a 150 K $\Omega$  (brown-green-yellow) 1/2 watt resistor from lug 2  $\blacktriangle$  of electrolytic capacitor E (S-3) to lug 2 of control K (NS).
- ( ) R71, C46. Referring to Detail 7A, prepare a 33 K $\Omega$  (orange-orange-orange) 1/2 watt resistor and .02  $\mu$ fd disc ceramic combination.



Detail 7A

- ( ) Connect this combination from lug 3 of electrolytic capacitor E (S-2) to lug 2 of control K (S-3).

NOTE: When installing the tubular capacitors, be sure that the end marked with a band or shoulder is placed as shown in Pictorial 7.

- ( ) C44. Connect a .05  $\mu$ fd tubular capacitor from lug 3 of tube socket V5 (NS) to lug 1 of terminal strip L (S-2). Use sleeving on both leads.
- ( ) Connect a .05  $\mu$ fd tubular capacitor from lug 1 of tube socket V5 (NS) to lug 2 of terminal strip L (S-2). Use sleeving on both leads.

- ( ) C21. Connect a .05  $\mu$ fd tubular capacitor from lug 3 of tube socket V6 (NS) to lug 3 of terminal strip L (S-2). Use sleeving on both leads.
- ( ) C19. Connect a .05  $\mu$ fd tubular capacitor from lug 1 of tube socket V6 (NS) to lug 4 of terminal strip L (S-2). Use sleeving on both leads.
- ( ) R66. Connect a 36 K $\Omega$  (orange-blue-orange) 1/2 watt resistor from lug 3 of tube socket V5 (S-2) to lug 1 of terminal strip M (NS). Use sleeving on lead to V5.
- ( ) R30. Connect another 36 K $\Omega$  (orange-blue-orange) 1/2 watt resistor from lug 3 of tube socket V6 (S-2) to lug 2 of terminal strip M (NS). Use sleeving on lead to V6.
- ( ) R63, C43. Referring to Detail 7B, prepare a 22 K $\Omega$  (red-red-orange) 1/2 watt resistor and 56  $\mu$ fd disc ceramic capacitor series combination.

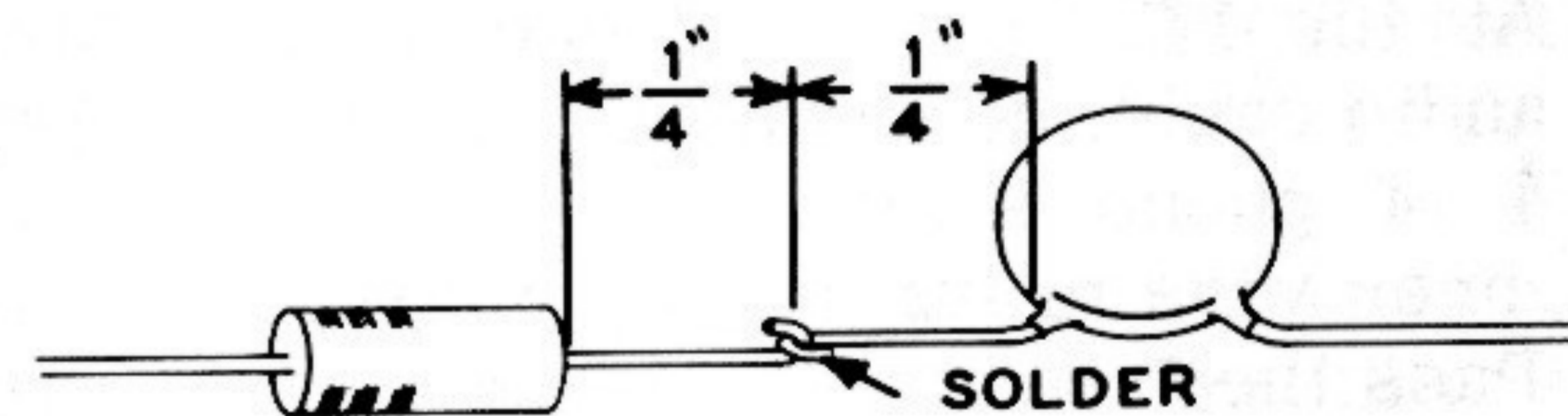

Detail 7B

- ( ) Connect the capacitor lead of this combination to lug 2 of tube socket V5 (NS), and connect the resistor lead of this combination to lug 1 of terminal strip M (S-4). Use sleeving on lead to V5.
- ( ) R27, C18. Referring to Detail 7B, prepare another 22 K $\Omega$  (red-red-orange) 1/2 watt resistor and 56  $\mu$ fd disc ceramic capacitor series combination.
- ( ) Connect the capacitor lead of this combination to lug 2 of tube socket V6 (NS) and connect the resistor lead to lug 2 of terminal strip M (S-2).
- ( ) R69. Connect a 100 K $\Omega$  (brown-black-yellow) 1/2 watt resistor between lugs 2 (S-2) and 3 (S-2) of terminal strip N.
- ( ) R28. Connect a 36 K $\Omega$  (orange-blue-orange) 1/2 watt resistor from lug 1 of tube socket V6 (S-2) to lug 3 of terminal strip Q (S-2). Use sleeving on the lead to V6.

- ( ) C17. Connect a 33  $\mu\mu\text{f}$  disc ceramic capacitor between lugs 1 (NS) and 2 (NS) of terminal strip Q.
- ( ) R29. Connect a 27 K $\Omega$  (red-violet-orange) 1/2 watt resistor between lugs 1 (S-3) and 2 (NS) of terminal strip Q.
- ( ) R24. Connect a 1000  $\Omega$  (brown-black-red) 1/2 watt resistor from lug 2 of terminal strip Q (S-4) to the bus wire (S-1).
- ( ) C42. Connect a 33  $\mu\mu\text{f}$  disc ceramic capacitor between lugs 1 (NS) and 2 (NS) of terminal strip P.
- ( ) R65. Connect a 27 K $\Omega$  (red-violet-orange) 1/2 watt resistor between lugs 1 (S-3) and 2 (NS) of terminal strip P.
- ( ) R60. Connect a 1000  $\Omega$  (brown-black-red) 1/2 watt resistor from lug 2 of terminal strip P (S-4) to the bus wire (S-1).
- ( ) C41. Connect a .1  $\mu\text{fd}$  tubular capacitor from lug 4 of terminal strip P (NS) to lug 7 of tube socket V5 (NS). Use sleeving on the lead to V5.
- ( ) C16. Connect a .1  $\mu\text{fd}$  tubular capacitor from lug 4 of terminal strip P (S-6) to lug 7 of tube socket V6 (NS). Use sleeving on the lead to V6.
- ( ) R62. Connect a 220 K $\Omega$  (red-red-yellow) 1/2 watt resistor from lug 6 (NS) of tube socket V5 to lug 3 of terminal strip P (NS).
- ( ) R70. Connect a 150 K $\Omega$  (brown-green-yellow) resistor between lugs 2 (S-2) and 6 (S-2) of tube socket V5.
- ( ) R61. Connect a 680 K $\Omega$  (blue-gray-yellow) 1/2 watt resistor from lug 7 of tube socket V5 (S-2) to lug 3 of terminal strip P (NS).
- ( ) R64. Connect a 36 K $\Omega$  (orange-blue-orange) 1/2 watt resistor from lug 1 of tube socket V5 (S-2) to lug 3 of terminal strip P (NS). Use sleeving on the lead to V5.
- ( ) R26. Connect a 220 K $\Omega$  (red-red-yellow) 1/2 watt resistor from lug 6 of tube socket V6 (NS) to lug 3 of terminal strip P (NS).
- ( ) R71. Connect a 150 K $\Omega$  (brown-green-yellow) resistor between lugs 2 (S-2) and 6 (S-2) of tube socket V6.
- ( ) R25. Connect a 680 K $\Omega$  (blue-gray-yellow) 1/2 watt resistor from lug 7 of tube socket V6 (S-2) to lug 3 of terminal strip P (S-7). Use sleeving on lead to P.
- ( ) C35. Connect a .1  $\mu\text{fd}$  tubular capacitor from lug 6 of tube socket V4 (NS) to the bus wire (S-1).
- ( ) C10. Connect a .1  $\mu\text{fd}$  tubular capacitor from lug 6 of tube socket V3 (NS) to the bus wire (S-1). Use sleeving on lead to V3.
- ( ) R18. Connect a 100 K $\Omega$  (brown-black-yellow) 1/2 watt resistor from lug 5 of tube socket V3 (S-2) to lug 2 of terminal strip R (NS).
- ( ) R17. Connect a 270 K $\Omega$  (red-violet-yellow) 1/2 watt resistor from lug 6 of tube socket V3 (S-2) to lug 2 of terminal strip R (S-3).
- ( ) R54. Connect a 100 K $\Omega$  (brown-black-yellow) 1/2 watt resistor from lug 5 of tube socket V4 (S-2) to lug 1 of terminal strip R (NS).
- ( ) R53. Connect a 270 K $\Omega$  (red-violet-yellow) 1/2 watt resistor from lug 6 of tube socket V4 (S-2) to lug 1 of terminal strip R (S-4).
- ( ) R52. Connect one end of a 1000  $\Omega$  (brown-black-red) 1/2 watt resistor through lug 2 (NS) to lug 7 (S-1) of tube socket V4. Now solder lug 2 of V4 (S-2).
- ( ) Connect the other lead of this resistor to lug 1 of terminal strip S (S-1).
- ( ) R16. Connect one lead of another 1000  $\Omega$  (brown-black-red) 1/2 watt resistor through lug 2 (NS) to lug 7 (S-1) of tube socket V3. Now solder lug 2 of V3 (S-2). Connect the other lead of this resistor to lug 2 of terminal strip S (S-1).
- ( ) C30. Connect a .1  $\mu\text{fd}$  tubular capacitor from lug 6 of tube socket V2 (NS) to lug 4 of terminal strip W (NS).
- ( ) C33. Connect a .022  $\mu\text{fd}$  tubular capacitor from lug 7 of tube socket V2 (NS) to lug 3 of terminal strip W (S-2).

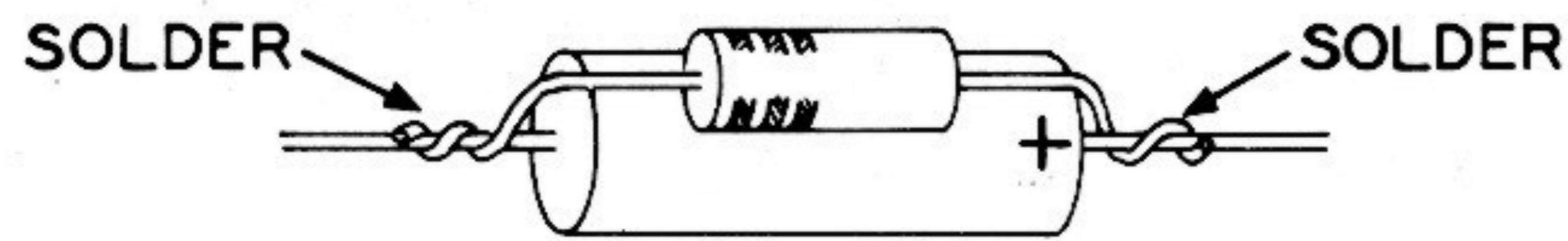

Detail 7C

- ( ) R37, C26. Referring to Detail 7C, prepare a 2700  $\Omega$  (red-violet-red) 1/2 watt resistor and 50  $\mu$ fd miniature electrolytic capacitor combination.
- ( ) Connect the positive (+) capacitor lead of this combination to lug 4 of tube socket V2 (S-1). Connect the other lead of this combination to the bus wire (S-1).
- ( ) R50. Connect a 100 K $\Omega$  (brown-black-yellow) 1/2 watt resistor between lugs 3 (NS) and 7 (S-2) of tube socket V2.
- ( ) R47. Connect a 100 K $\Omega$  (brown-black-yellow) LOW-NOISE resistor between lugs 3 (S-4) and 6 (S-2) of tube socket V2.
- ( ) R49. Connect a 2700  $\Omega$  (red-violet-red) 1/2 watt resistor from lug 9 of tube socket V2 (S-1) to the bus wire (S-1).
- ( ) R48. Connect a 1 megohm (brown-black-green) 1/2 watt resistor from lug 8 of tube socket V2 (S-2) to the bus wire (S-1).
- ( ) C28. Connect a .01  $\mu$ fd disc ceramic capacitor from lug 1 of terminal strip W (NS) to the bus wire (S-1).
- ( ) C29. Connect a .0035  $\mu$ fd disc ceramic capacitor between lugs 1 (NS) and 2 (NS) of terminal strip W.
- ( ) R45. Connect a 22 K $\Omega$  (red-red-orange) 1/2 watt resistor between lugs 1 (S-3) and 2 (NS) of terminal strip W.
- ( ) R46. Connect a 470 K $\Omega$  (yellow-violet-yellow) 1/2 watt resistor between lugs 2 (S-4) and 4 (S-2) of terminal strip W.
- ( ) C3. Connect a .01  $\mu$ fd disc ceramic capacitor from lug 1 of terminal strip X (NS) to the bus wire (S-1).
- ( ) C4. Connect a .0035  $\mu$ fd disc ceramic capacitor between lugs 1 (NS) and 2 (NS) of terminal strip X.
- ( ) R9. Connect a 22 K $\Omega$  (red-red-orange) 1/2 watt resistor between lugs 1 (S-3) and 2 (NS) of terminal strip X.
- ( ) R10. Connect a 470 K $\Omega$  (yellow-violet-yellow) 1/2 watt resistor between lugs 2 (S-4) and 4 (NS) of terminal strip X.
- ( ) C5. Connect a .1  $\mu$ fd tubular capacitor from lug 6 of tube socket V1 (NS) to lug 4 of terminal strip X (S-2).
- ( ) C8. Connect a .022  $\mu$ fd tubular capacitor from lug 7 of tube socket V1 (NS) to lug 3 of terminal strip X (S-2).
- ( ) R8, C2. Referring to Detail 7C, prepare a 2700  $\Omega$  (red-violet-red) 1/2 watt resistor and 50  $\mu$ fd miniature electrolytic capacitor combination.
- ( ) Connect the positive (+) capacitor lead of this combination to lug 4 of tube socket V1 (S-1). Connect the other lead of this combination to lug 2 of terminal strip T (S-1).
- ( ) R14. Connect a 100 K $\Omega$  (brown-black-yellow) 1/2 watt resistor between lugs 3 (NS) and 7 (S-2) of tube socket V1.
- ( ) R11. Connect a 100 K $\Omega$  (brown-black-yellow) LOW-NOISE resistor between lugs 3 (S-3) and 6 (S-2) of tube socket V1.
- ( ) R13. Connect a 2700  $\Omega$  (red-violet-red) 1/2 watt resistor from lug 9 of tube socket V1 (S-1) to the bus wire (S-1).
- ( ) R12. Connect a 1 megohm (brown-black-green) 1/2 watt resistor from lug 8 of tube socket V1 (S-2) to the bus wire (S-1).
- ( ) R33. Connect a 100  $\Omega$  7 watt resistor from lug 1 of terminal strip C (S-2) to lug 3 of terminal strip H (NS). Position the body of this resistor against the chassis.
- ( ) C20. Connect the positive (+) lead of the 50  $\mu$ fd 25 volt electrolytic capacitor to lug 2 of terminal strip C (S-1). Connect the other lead of this capacitor to lug 3 of terminal strip H (S-3).
- ( ) R7. Connect a 47 K $\Omega$  (yellow-violet-orange) 1/2 watt resistor between lugs 1 (S-2) and 2 (S-2) of phono socket BG.

- ( ) R38. Connect a 47 K $\Omega$  (yellow-violet-orange) 1/2 watt resistor between lugs 3 (S-2) and 4 (S-2) of phono socket BG.
- ( ) R32. Connect a 470 K $\Omega$  (yellow-violet-yellow) 1/2 watt resistor from lug 2 of terminal strip B (S-3) to lug 2 of tube socket V8 (S-2).
- ( ) R31. Connect a 470 K $\Omega$  (yellow-violet-yellow) 1/2 watt resistor from lug 1 of terminal strip B (S-4) to lug 2 of tube socket V7 (S-2).
- ( ) R67. Connect a 470 K $\Omega$  (yellow-violet-yellow) 1/2 watt resistor from lug 2 of terminal strip A (S-4) to lug 2 of tube socket V10 (S-2).
- ( ) R68. Connect another 470 K $\Omega$  (yellow-violet-yellow) 1/2 watt resistor from lug 1 of terminal strip A (S-4) to lug 2 of tube socket V9 (S-2).
- ( ) Referring to Detail 7D, mount the line cord and line cord strain relief in the hole between the two AC sockets. Leave 2-1/2" of wire inside of the chassis.
- ( ) Connect either line cord wire to lug 1 of AC socket BA (S-3). Connect the other wire to lug 2 of AC socket BA (S-2).

This completes the wiring of your HEATHKIT AA-151 Stereo Amplifier.

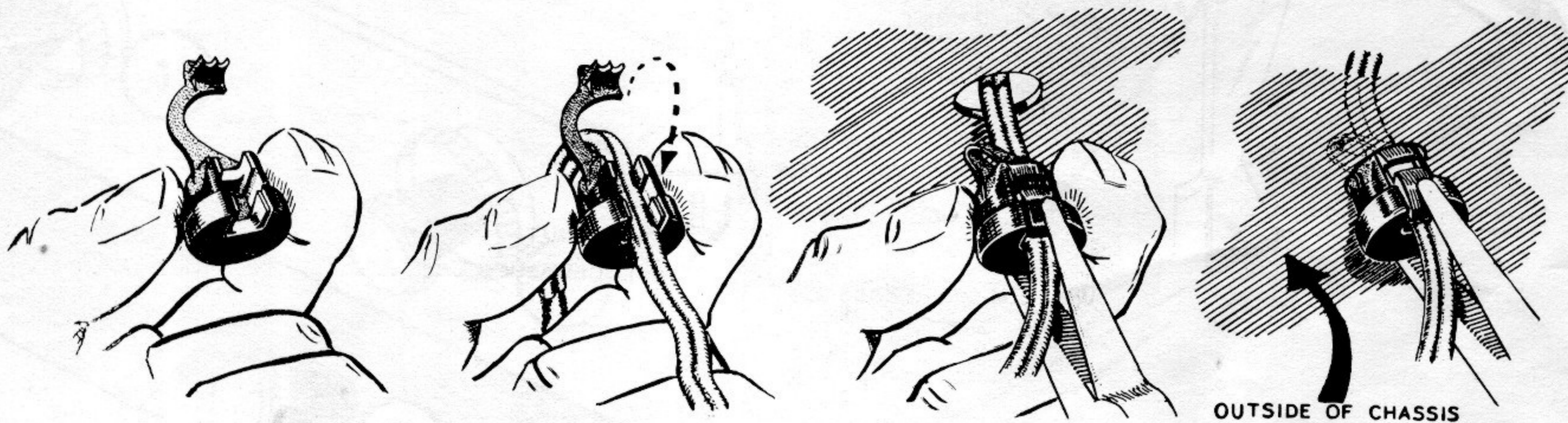

Detail 7D

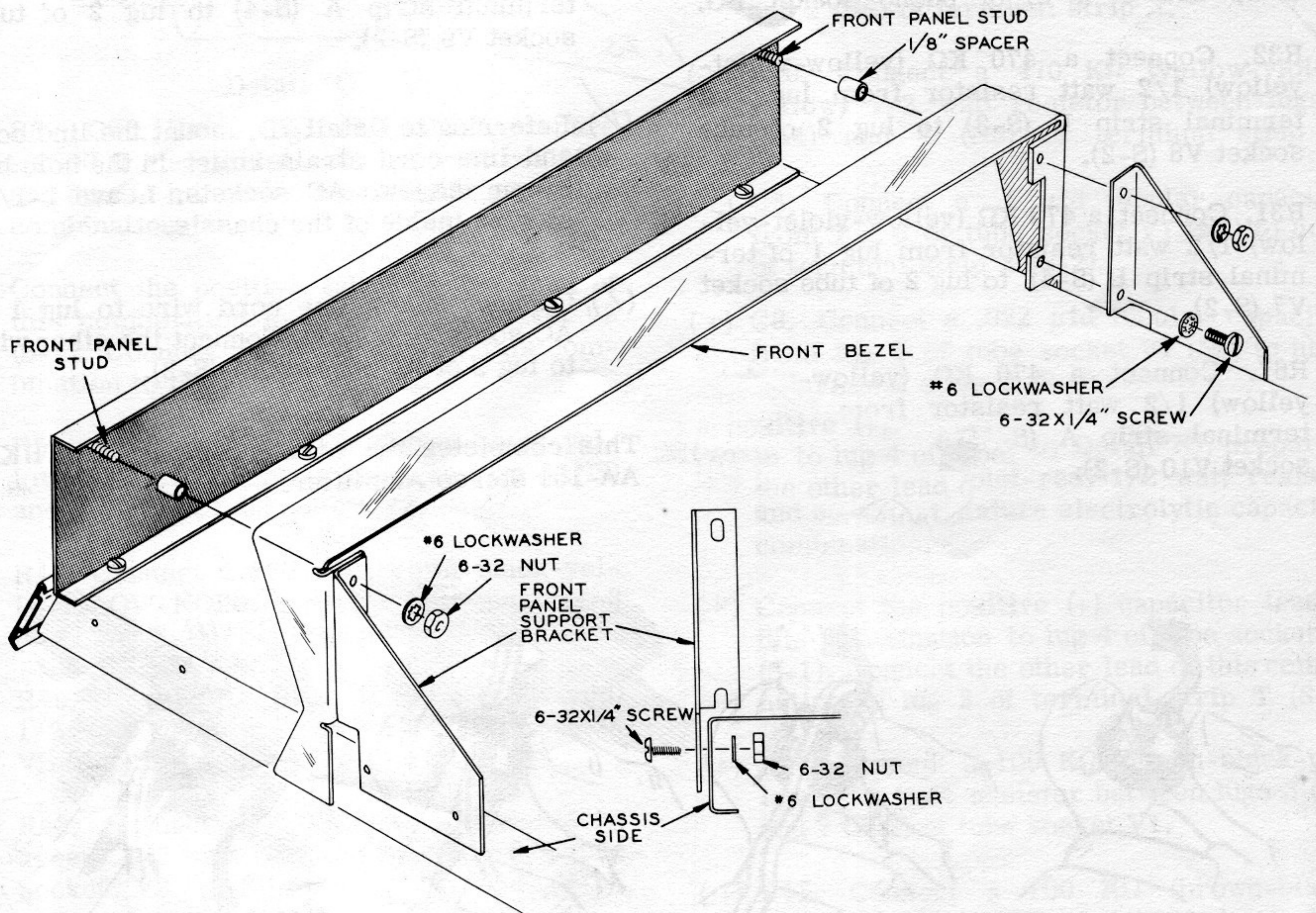

Pictorial 8

Refer to Pictorial 8 for the following steps.

- ( ) Locate the front bezel and place a 6-32 self-tapping screw in the bottom hole of each mounting flange. Now remove the 6-32 self-tapping screws. Using these prethreaded holes, secure a front panel support bracket to each end of the front bezel. Use 6-32 x 1/4" screws and #6 lockwashers.
- ( ) Mount the front bezel and support brackets to the front panel and chassis as shown in Pictorial 8. Place 1/8" spacers on each stud on the front panel. Place the bezel on the studs, then secure the support brackets to the chassis with #6 hardware. Now secure the bezel to the front panel with #6 lockwashers and 6-32 nuts on the studs.

## TEST AND CONNECTIONS

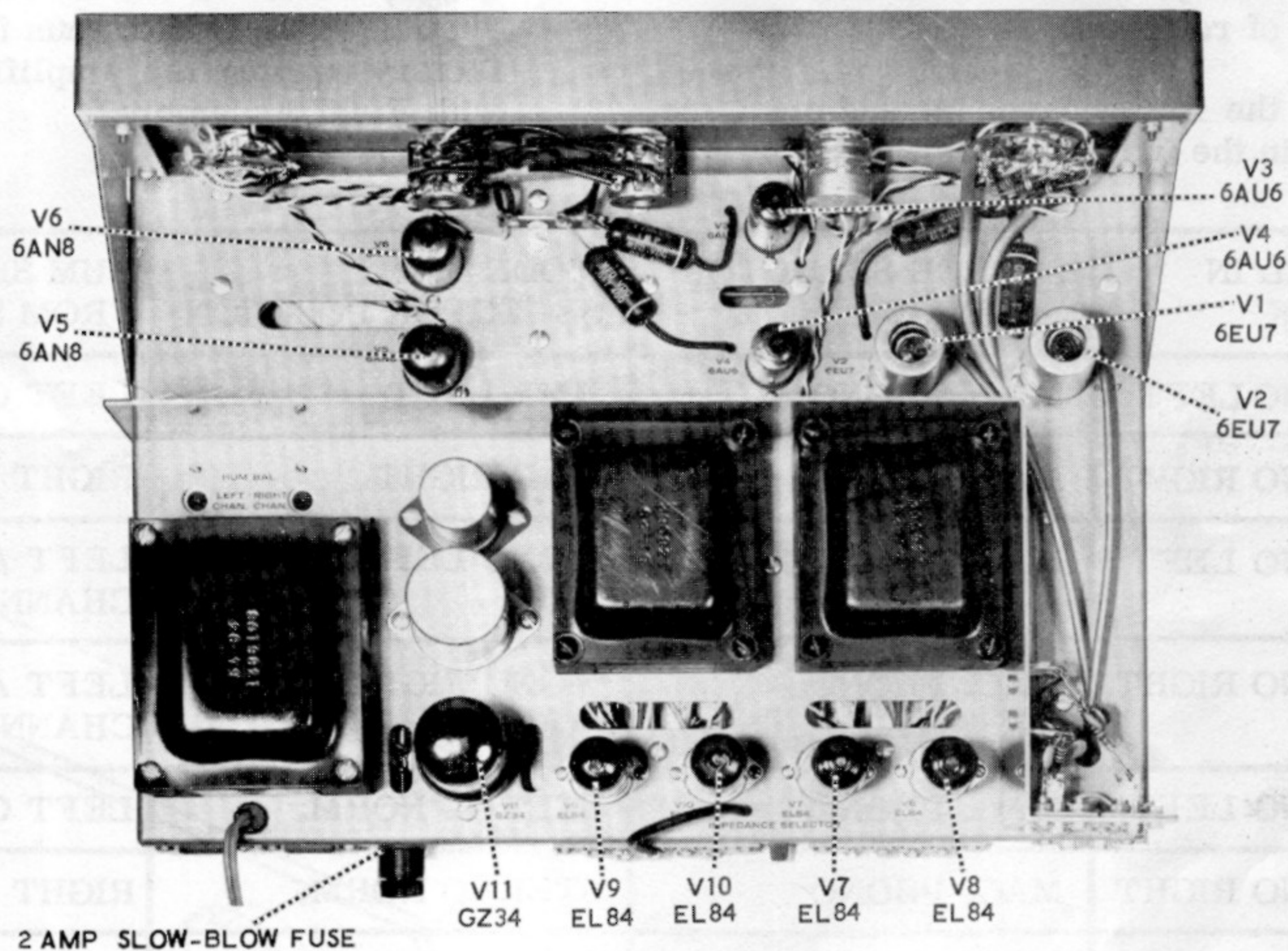

Pictorial 9

Refer to Pictorial 9 for the following steps.

- ( ) Carefully inspect the bottom of the chassis to be sure that all solder splashes or excess lead lengths have been removed. Inspect each solder connection to be sure that a poor solder joint does not exist and that solder has not overflowed from a connection, causing a short circuit.

**IMPORTANT WARNING: TUBES CAN BE DAMAGED WHEN INSTALLING THEM IN THEIR SOCKETS. THEREFORE, USE EXTREME CARE WHEN INSTALLING TUBES, AS WE DO NOT GUARANTEE OR REPLACE TUBES BROKEN DURING HANDLING OR INSTALLATION.**

- ( ) Referring to Pictorial 9, install the tubes in their appropriate tube sockets. Mount the tube shields on tube sockets V1 and V2.
- ( ) Install a 2 amp fuse in the fuse holder.
- ( ) Referring to Detail 9A, install the knobs on the front panel and control panel shafts.
- ( ) Connect one end of the left channel speaker leads to the left channel "C" terminal.

Connect the other lead of the left channel speaker to the tap that matches the speaker coil impedance, 4  $\Omega$ , 8  $\Omega$ , or 16  $\Omega$ .

- ( ) Connect the right channel speaker leads to the right channel speaker "C" and "S" SPKR terminals. Connect the impedance matching wire to the terminal which corresponds to the right speaker impedance, 4  $\Omega$ , 8  $\Omega$ , or 16  $\Omega$ . **CAUTION:** Do not operate the amplifier without a load across the speaker terminals.
- ( ) Plug the amplifier into a 117 volt 50/60 cycle AC receptacle. Turn the amplifier POWER switch to ON.
- ( ) The pilot lamp should glow and the tube filaments should light.
- ( ) Insert a small screwdriver into the input jacks. This injects a 60 cycle test signal for testing purposes. There is no shock hazard in a properly wired amplifier. Slowly advance each section of the VOLUME control until hum is heard from the speakers.

Do not advance the VOLUME control further than necessary. The tone controls should be at 1/2 of rotation.

- ( ) Refer to the following chart and place the controls in the indicated positions.

- ( ) If difficulty is encountered in the steps below, refer to the In Case Of Difficulty section. If operation thus far seems satisfactory, unplug the amplifier and proceed with Final Assembly.

PLACE NAIL IN INPUT JACK	SOURCE SELECTOR POSITION	MODE SELECTOR POSITION	HUM SHOULD BE HEARD FROM SPEAKER ONLY
MAG. PHONO LEFT	MAG. PHONO	AMP LEFT	LEFT CHANNEL
MAG. PHONO RIGHT	MAG. PHONO	AMP RIGHT	RIGHT CHANNEL
MAG. PHONO LEFT	MAG. PHONO	MONO LEFT SOURCE	LEFT AND RIGHT CHANNEL
MAG. PHONO RIGHT	MAG. PHONO	MONO RIGHT SOURCE	LEFT AND RIGHT CHANNEL
MAG. PHONO LEFT	MAG. PHONO	STEREO NORM.	LEFT CHANNEL
MAG. PHONO RIGHT	MAG. PHONO	STEREO NORM.	RIGHT CHANNEL
MAG. PHONO LEFT	MAG. PHONO	STEREO REV.	RIGHT CHANNEL
MAG. PHONO RIGHT	MAG. PHONO	STEREO REV.	LEFT CHANNEL
XTAL PHONO LEFT	XTAL PHONO	STEREO NORM.	LEFT CHANNEL
XTAL PHONO RIGHT	XTAL PHONO	STEREO NORM.	RIGHT CHANNEL
TUNER LEFT	TUNER	STEREO NORM.	LEFT CHANNEL
TUNER RIGHT	TUNER	STEREO NORM.	RIGHT CHANNEL
AUX. LEFT	AUX.	STEREO NORM.	LEFT CHANNEL
AUX. RIGHT	AUX.	STEREO NORM.	RIGHT CHANNEL

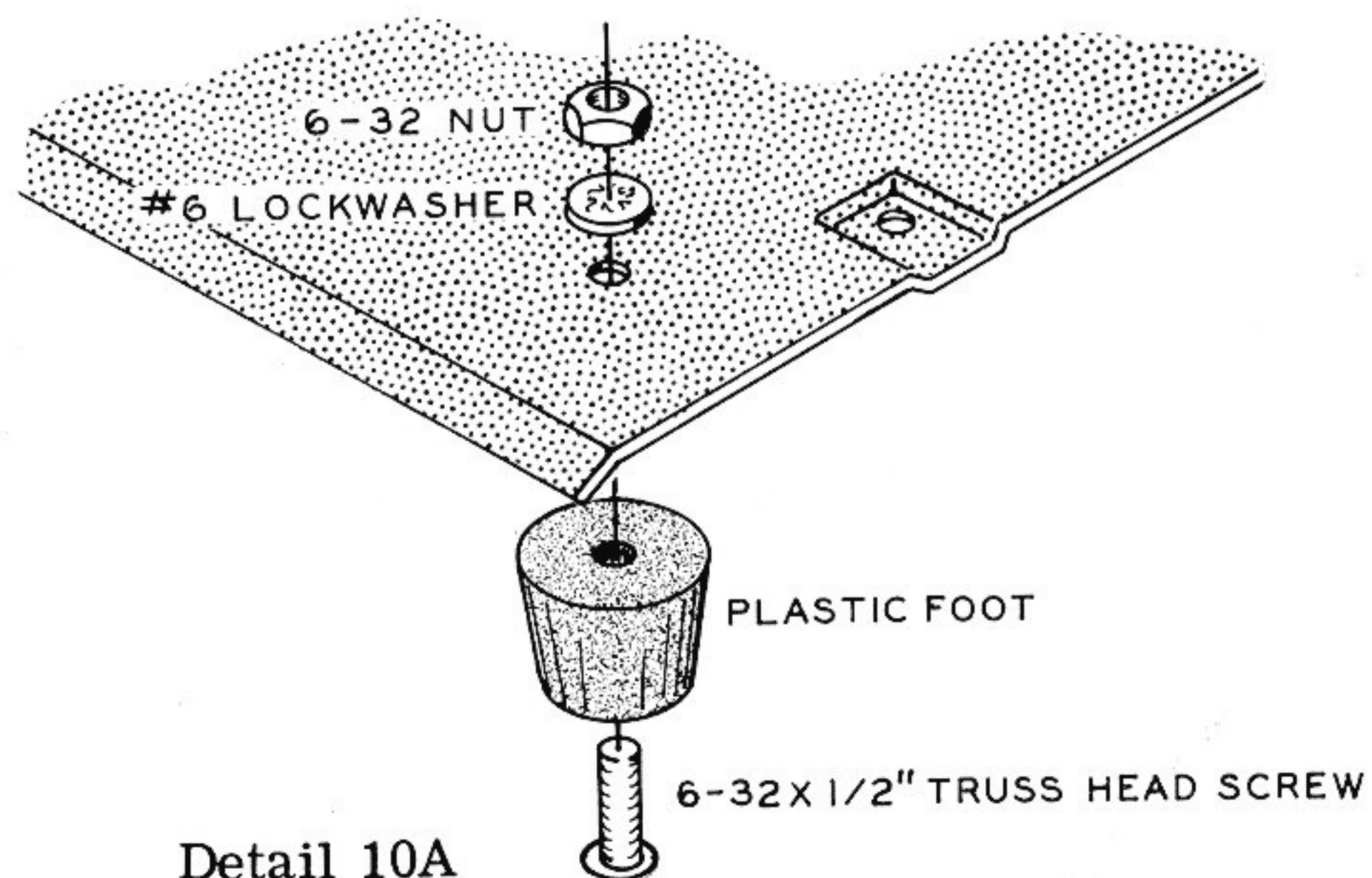



## FINAL ASSEMBLY

Refer to Pictorial 10 for the following steps.

- ( ) Locate the bottom plate and referring to Detail 10A, firmly mount a plastic foot in each corner. Use 6-32 x 1/2" truss head screws, #6 lockwashers, and 6-32 nuts.
- ( ) Mount the bottom cover to the chassis with eight #6 sheet metal screws, two on each edge and four on the rear apron. The bent edge of the bottom cover must fit under the bottom edge of the control panel.
- ( ) Taking care that the top cover clears the electrolytic capacitor, slide the top cover over the amplifier from the back and fasten it to the bottom, using six sheet metal screws, three in each side.
- ( ) Carefully remove all of the paper backing from the nameplate. Apply the nameplate to the front of the amplifier with firm, even finger pressure.

This completes the assembly of your Model AA-151 Stereo High Fidelity Amplifier. Normally, the output of both channels of this amplifier are connected to suitable speaker systems. If you intend to use only one speaker system, connect it to one of the channels, and connect the

other channel to a resistive load. The resistive load will prevent the unused channel from "running free," which could damage the circuit parts in the output stage of an unused channel.

You may use a 4 ohm, 8 ohm, or 16 ohm high wattage resistor for the resistive load. Connect this resistor to the proper output terminals of the unused channel.

### FILAMENT BALANCE CONTROL ADJUSTMENT

Plug the amplifier into a 117 volt AC receptacle. Place the SOURCE selector switch in the MAG. PHONO position and the MODE selector in AMP LEFT position. With no connection to the input jacks, turn the VOLUME control clockwise until hum is clearly heard from the left speaker. Turn the amplifier on its side and adjust the LEFT FILAMENT BALANCE control for minimum hum from the left speaker.

- ( ) Place the MODE selector switch in the AMP RIGHT position. Rotate the VOLUME control until hum is heard clearly from the right speaker. Adjust the RIGHT FILAMENT BALANCE control for minimum hum from the right speaker. NOTE: Some benefit may be obtained by readjustment if the entire system is installed.

## INSTALLATION AND OPERATION

Heat is normally generated in all power amplifiers, therefore, adequate ventilation around the cabinet is necessary. At least 1" of open area behind the rear apron and 3" above the top of the cabinet is considered minimum for adequate ventilation. Vertical mounting of the chassis is not recommended due to the high operating temperature of the amplifier.

Refer to Pictorial 11 on Page 36 which shows a typical installation of this amplifier in a stereo system. The system illustrated in Pictorial 11 is provided simply as an example and should be used only as a guide in connecting your system. There are, of course, many other possible combinations of equipment that will provide similar results.

The XTAL PHONO input was designed for crystal or piezoelectric phono cartridges, but may

be used for any high level input source. The TUNER and AUX. inputs are identical in design and may be used for high level inputs from practically any type of signal source.

The SOURCE selector switch selects the desired signal source, as indicated on the front panel, without interference from the other inputs.

The MODE selector switch routes either or both input signals from the selected sources to the input of the power amplifiers. AMP LEFT and AMP RIGHT positions route the input signal only through its respective power amplifier and speaker. No audio will be reproduced by the opposite speaker. MONO LEFT SOURCE and MONO RIGHT SOURCE positions route the input signal to both power amplifiers and it will be reproduced by both the left and right speakers.

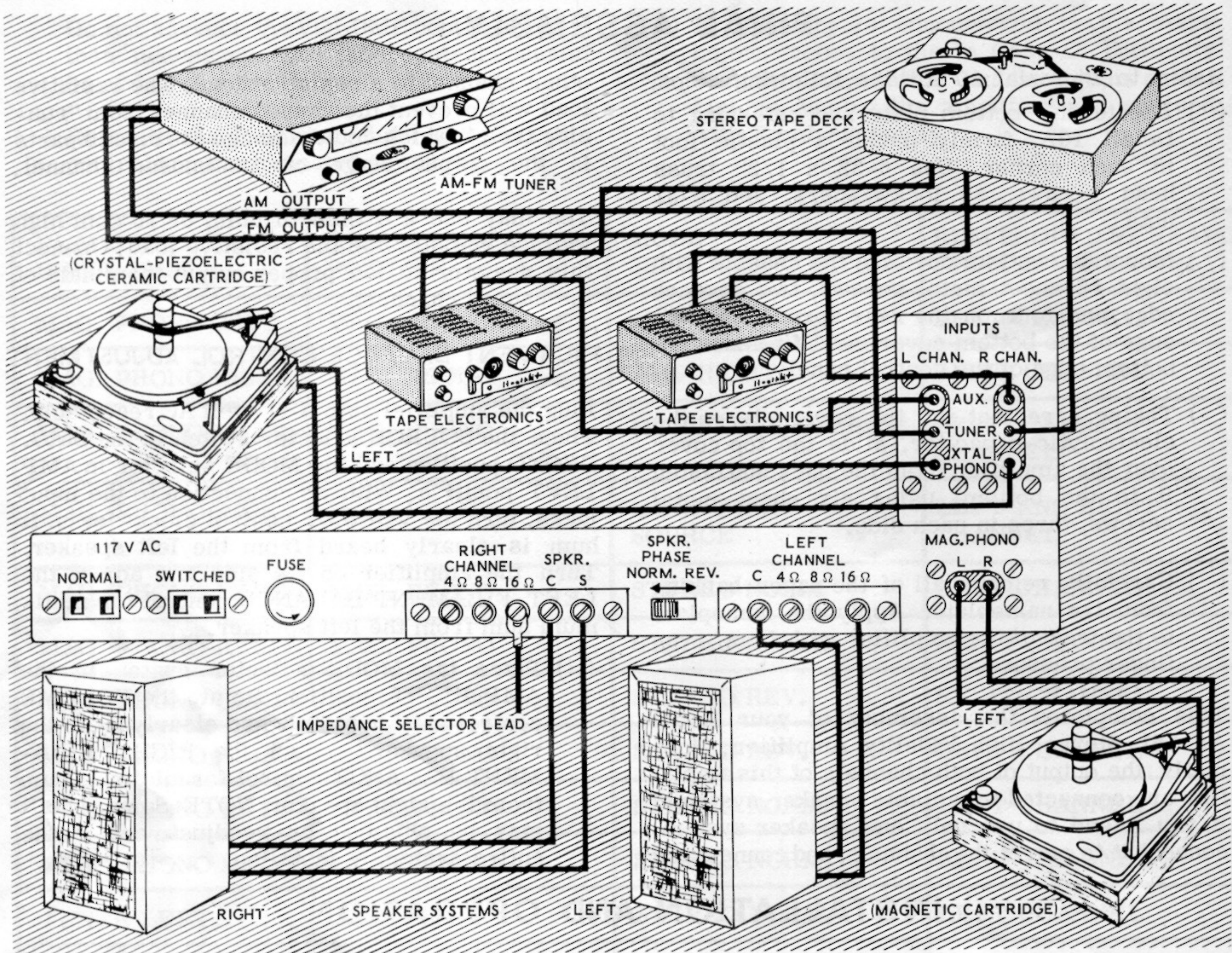

Pictorial 11

STEREO NORM. and STEREO REV. positions route the left and right input signals to their respective amplifiers and speakers, or opposite amplifiers and speakers. As an example, the listener can change the direction of travel of a recorded train sound from left to right, to right to left. He may place the string section of an orchestra to the left or to the right of the brass section as desired.

The VOLUME control may be operated as a dual-tandem or concentric control. For concentric operation simply hold one knob stationary, and turn the free knob. This feature allows the control to be used as a balance control.

The BASS and TREBLE controls are dual-tandem and therefore adjust the tone emphasis or attenuation of both amplifiers simultaneously. These tone controls make it possible to reproduce tones as they were recorded, or to adjust the tones for individual listening preference.

The SPKR. PHASE switch is located on the rear apron of the AA-151. This switch is used to reverse the right channel speaker connections. The NORM. position is correct if the signal sources selected are in phase with one another and the speakers are in phase. When either the input signals or the speakers are out of phase, the phase reversal switch will compensate for the

difference. If the material being produced is out of phase there will be slight cancellation of program material, especially at the low frequencies. To determine whether or not the reproduced audio is in or out of phase, adjust the output of each speaker individually to produce the same level of audio. This can be done by setting the MODE selector switch in the AMP LEFT position and adjusting the left channel VOLUME control for normal listening level from the left speaker. Switch the MODE selector switch to AMP RIGHT. Holding the left channel VOLUME control knob in a stationary position, set the right channel VOLUME control to a normal listening level from the right speaker.

Once the two speaker output levels are balanced, place the MODE selector switch in the stereo NORM. position and switch the SPKR. PHASE switch from NORM. to the REV. posi-

tion. You will note a slight difference in total output level and a difference in the direction from which the program material seems to be originating. The highest output level and fullness of sound will coincide with the proper position of the SPKR. PHASE switch. With some stereo material, this test may be difficult to make because of extreme separation between channels. It is suggested that a standard monophonic record be used under the conditions described above. The sound will be full and centered when proper phase relationships are achieved.

It is a good practice to leave the VOLUME control for the unused preamplifier in its full counterclockwise position when operating the amplifier for monophonic reproduction. This will avoid any possibility of interference from the unused channel.

## IN CASE OF DIFFICULTY

1. Recheck the wiring. Trace each lead in colored pencil on the Pictorial as it is checked. It is frequently helpful to have a friend check your work. Someone who is not familiar with the unit may notice something consistently overlooked by the constructor.
2. It is interesting to note that about 90% of the kits that are returned for repair, do not function properly due to poor connections and soldering. Therefore, many troubles can be eliminated by reheating all connections to make sure that they are soldered as described in the Proper Soldering Techniques section of this manual.
3. Check to be sure that all tubes are in their proper locations. Make sure that all tubes light up properly.
4. Check the tubes with a tube tester or by substitution of tubes of the same types and known to be good.
5. Check the values of the component parts. Be sure that the proper part has been wired into the circuit, as shown in the pictorial diagrams and as called out in the wiring instructions.
6. Check for bits of solder, wire ends or other foreign matter which may be lodged in the wiring beneath the chassis.
7. If, after careful checks, the trouble is still not located and a voltmeter is available, check voltage readings against those found on the Schematic Diagram. NOTE: All voltage readings were taken with a HEATHKIT Vacuum Tube Voltmeter. Voltages may vary as much as 10% due to line voltage variations.
8. A review of the Circuit Description will prove helpful in indicating where to look for trouble.

**CAUTION:** There is high voltage present at various points throughout the AA-151. Do not touch these. Be certain you have the proper test point located before proceeding with the following checks. Do not touch the chassis other than at the points indicated.

( ) Place the front panel controls as follows:

SOURCE selector	MAG. PHONO.
VOLUME control	1/4 turn from counter-clockwise position. (Do not adjust this control higher than necessary to obtain an audible sound in the speaker, as serious damage could result to the output tubes or speakers due to the high gain of the amplifier.)
BASS and TREBLE controls	1/2 rotation from counterclockwise.
MODE selector	STEREO NORM.

### LEFT CHANNEL TEST

Touch the control grid (pin 2) of V7 and V8 with a screwdriver. A faint sound should be heard from the left channel speaker. Touch the control grid (pin 2) of V6B, the sound should increase slightly. Then proceed to pin 8 of V6A, pin 1 of V3, pin 8 of V1B, then pin 5 of V1A.

### RIGHT CHANNEL TEST

Touch the control grid (pin 2) of V9 and V10 with a screwdriver. A faint sound should be heard from the right channel speaker. Touch the control grid (pin 2) of V5B, sound should increase slightly. Proceed to pin 8 of V5A, pin 1 of V4, pin 8 of V2B, then pin 5 of V2A.

The point at which no sound is heard is the stage where the difficulty lies. Recheck the voltages, wiring and components in this particular area.

## SERVICE INFORMATION

### SERVICE

If, after applying the information contained in this manual and your best efforts, you are still unable to obtain proper performance, it is suggested that you take advantage of the technical facilities which the Heath Company makes available to its customers.

The Technical Consultation Department is maintained for your benefit. This service is available to you at no charge. Its primary purpose is to provide assistance for those who encounter difficulty in the construction, operation or maintenance of HEATHKIT equipment. It is not intended, and is not equipped to function as a general source of technical information involving kit modifications nor anything other than the normal and specified performance of HEATHKIT equipment.

Although the Technical Consultants are familiar with all details of this kit, the effectiveness of their advice will depend entirely upon the amount and the accuracy of the information furnished by you. In a sense, YOU MUST QUALIFY for GOOD technical advice by helping the consultants to help you. Please use this outline:

1. Before writing, fully investigate each of the hints and suggestions listed in this manual under In Case Of Difficulty. Possibly it will not be necessary to write.
2. When writing, clearly describe the nature of the trouble and mention all associated equipment. Specifically report operating procedures, switch positions, connections to other units and anything else that might help to isolate the cause of trouble.
3. Report fully on the results obtained when testing the unit initially and when following the suggestions under In Case Of Difficulty. Be as specific as possible and include voltage readings if test equipment is available.
4. Identify the kit model number and date of purchase if available. Also mention the date of the kit assembly manual. (Date at bottom of Page 1.)
5. Print or type your name and address, preferably in two places on the letter.

With the preceding information, the consultant will know exactly what kit you have, what you would like it to do for you and the difficulty you

wish to correct. The date of purchase tells him whether or not engineering changes have been made since it was shipped to you. He will know what you have done in an effort to locate the cause of trouble and, thereby, avoid repetitious suggestions. In short, he will devote full time to the problem at hand, and through his familiarity with the kit, plus your accurate report, he will be able to give you a complete and helpful answer. If replacement parts are required, they will be shipped to you, subject to the terms of the Warranty.

The Factory Service facilities are also available to you, in case you are not familiar enough with electronics to provide our consultants with sufficient information on which to base a diagnosis of your difficulty, or in the event that you prefer to have the difficulty corrected in this manner. You may return the completed instrument to the Heath Company for inspection and necessary repairs and adjustments. You will be charged a minimal service fee, plus the price of any additional parts or material required. However, if the completed kit is returned within the Warranty period, parts charges will be governed by the terms of the Warranty. State the date of purchase, if possible.

Local Service by Authorized HEATHKIT Service Centers is also available in some areas and often will be your fastest, most efficient method of obtaining service for your HEATHKIT equipment. Although you may find charges for local service somewhat higher than for factory service, the amount of increase is usually offset by the transportation charge you would pay if you elected to return your kit to the Heath Company.

HEATHKIT Service Centers will honor the regular 90 day HEATHKIT Parts Warranty on all kits, whether purchased through a dealer or directly from Heath Company; however, it will be necessary that you verify the purchase date of your kit.

Under the conditions specified in the Warranty, replacement parts are supplied without charge; however, if the Service Center assists you in locating a defective part (or parts) in your kit, or installs a replacement part for you, you may be charged for this service.

HEATHKIT equipment purchased locally and returned to Heath Company for service must be accompanied by your copy of the dated sales receipt from your authorized HEATHKIT dealer in order to be eligible for parts replacement under the terms of the Warranty.

**THIS SERVICE POLICY APPLIES ONLY TO COMPLETED EQUIPMENT CONSTRUCTED IN ACCORDANCE WITH THE INSTRUCTIONS AS STATED IN THE MANUAL.** Equipment that has been modified in design will not be accepted for repair. If there is evidence of acid core solder or paste fluxes, the equipment will be returned NOT repaired.

For information regarding modification of HEATHKIT equipment for special applications, it is suggested that you refer to any one or more of the many publications that are available on all phases of electronics. They can be obtained at or through your local library, as well as at most electronic equipment stores. Although the Heath Company sincerely welcomes all comments and suggestions, it would be impossible to design, test, evaluate and assume responsibility for proposed circuit changes for special purposes. Therefore, such modifications must be made at the discretion of the kit builder, using information available from sources other than the Heath Company.

## REPLACEMENTS

Material supplied with HEATHKIT products has been carefully selected to meet design requirements and ordinarily will fulfill its function without difficulty. Occasionally improper instrument operation can be traced to a faulty component. Should inspection reveal the necessity for replacement, write to the Heath Company and supply all of the following information.

- A. Thoroughly identify the part in question by using the part number and description found in the manual Parts List.
- B. Identify the type and model number of kit in which it is used.
- C. Mention date of purchase.
- D. Describe the nature of defect or reason for requesting replacement.

The Heath Company will promptly supply the necessary replacement. PLEASE DO NOT RETURN THE ORIGINAL COMPONENT UNTIL SPECIFICALLY REQUESTED TO DO SO. Do not dismantle the component in question as this will void the guarantee. This replacement policy does not cover the free replacement of parts that may have been broken or damaged through carelessness on the part of the kit builder.

### SHIPPING INSTRUCTIONS

In the event that your instrument must be returned for service, these instructions should be carefully followed.

Be sure to include all tubes and interconnecting audio cables. The cabinet and bottom plate should be securely fastened to the chassis.

ATTACH A TAG TO THE EQUIPMENT BEARING YOUR NAME, COMPLETE ADDRESS, DATE OF PURCHASE, AND A BRIEF DESCRIPTION OF

THE DIFFICULTY ENCOUNTERED. Wrap the equipment in heavy paper, exercising care to prevent damage. Place the wrapped equipment in a stout carton of such size that at least three inches of shredded paper, excelsior, or other resilient packing material can be placed between all sides of the wrapped equipment and the carton. Close and seal the carton with gummed paper tape, or alternately, tie securely with stout cord. Clearly print the address on the carton as follows:

To: HEATH COMPANY  
Benton Harbor, Michigan

Include your name and return address on the outside of the carton. Preferably affix one or more "Fragile" or "Handle With Care" labels to the carton, or otherwise so mark with a crayon of bright color. Ship by insured parcel post or prepaid express; note that a carrier cannot be held responsible for damage in transit if, in HIS OPINION, the article is inadequately packed for shipment.

## WARRANTY

Heath Company warrants that for a period of three months from the date of shipment, all Heathkit parts shall be free of defects in materials and workmanship under normal use and service and that in fulfillment of any breach of such warranty, Heath Company shall replace such defective parts upon the return of the same to its factory. The foregoing warranty shall apply only to the original buyer, and is and shall be in lieu of all other warranties, whether express or implied and of all other obligations or liabilities on the part of Heath Company and in no event shall Heath Company be liable for any anticipated profits, consequential damages, loss of time or other losses incurred by the buyer in connection with the purchase, assembly or operation of Heathkits or components thereof. No replacement shall be made of parts damaged by the buyer in the course of handling or assembling Heathkit equipment.

NOTE: The foregoing warranty is completely void and we will not replace, repair or service instruments or parts thereof in which acid core solder or paste fluxes have been used.

HEATH COMPANY