

# YAMAHA PX-2

Natural Sound  
Linear Tracking  
Turntable



OWNER'S MANUAL



YAMAHA thanks and congratulates you  
on your purchase of  
the YAMAHA Linear Tracking Stereo Turntable Unit, PX-2.  
The PX-2 uses for its tonearm section  
a linear tracking straight arm  
with excellent tracking ability,  
in addition to  
a direct drive turntable driven by a DC 4-phase,  
8-pole coreless Hall motor  
with a starting torque of not less than 1 kg-cm.  
Easy-to-operate because of its fully automatic control functions,  
the PX-2 represents the best in record playing systems.

#### CONTENTS

Features . . . . .	2
CAUTION - Read This First . . . . .	3
Before Assembly and Accessories . . . . .	4
Assembly and Connections . . . . .	5
Identification and Functions of Controls . . . . .	7
Adjusting the Tonearm . . . . .	9
How to Play Discs . . . . .	10
Specifications . . . . .	11
Trouble Shooting . . . . .	12
Block Diagram . . . . .	13
Schematic Diagram . . . . .	14

## FEATURES

### Linear Tracking Straight Arm

Employing a linear tracking arm that boasts a horizontal tracking error angle of within  $\pm 0.15^\circ$ , offset angle and inside force of "0", the PX-2 features reproduction of clearer sounds with less distortion than conventional Swing type tonearms. And because of its tonearm height adjusting mechanism, it enables stroke changes within  $\pm 4\text{mm}$ , and accepts practically all kinds of cartridges currently available on the market.

### Fully Automatic Control Mechanisms

By intergrating the disc-size selector with the PLAY switch of the turntable, the unit is provided not only with automatic control functions that enable one-touch AUTO LEAD-IN, AUTO-RETURN and REPEAT play, but also with manual control functions that enable speed change, CUEING UP, CUEING DOWN and LEAD-IN and LEAD-OUT without opening the dust cover.

### Quartz Oscillator Phase-Locked Turntable

The speed of revolution of the DC 4-phase, 8-pole coreless Hall motor (Starting torque: Not less than 1 kg-cm) is locked by a PLL (Phase locked loop) mechanism, which uses the oscillating frequency of a quartz crystal oscillator as its reference frequency. Freedom from temperature- and time-induced drift and temporal changes ensures, stable and powerful rotation of the turntable with speed accuracy as high as  $\pm 20$  ppm, or better. When steady rotation of the platter is achieved, the LOCKED indicator lights up to indicate phase-lock.

### Heavyweight Platter and Mat

This platter, which measures 31 cm in diameter, weights 2.1kg and has a moment of inertia of  $270 \text{ kg-cm}^2$  (both figures including the rubber mat). Wow and flutter have been suppressed to the minimum and smooth rotation ensured.

### Heavyweight Cabinet and Dust Cover

The cabinet is made of 5 mm-thick aluminum diecast panels featuring high rigidity. The heavy-weight-class body weights 17 kg in total. The dust cover is made of 5 mm-thick, 1.3 kg. This design protects the turntable unit from harmful external vibrations and provides resistance against 'howling' (acoustic feedback from speakers).

### Other Features

Other features include a constant-voltage power circuit providing sufficient allowance and operating properties. In addition, the PX-2 has been designed to provide the user optimum ease of use, with many features exclusive to Yamaha. At Yamaha, we're always a few steps ahead of other audio makers.

### WARNING

To prevent fire or shock hazard, do not expose this appliance to rain or moisture.

### IMPORTANT!

Please record the serial number of your unit in the space below:

Model Name: PX-2

Serial No.

The serial number is located on the rear of the chassis.

### Special Instructions for British Model

#### IMPORTANT!

The wires in the mains lead are coloured in accordance with the following code:

Blue: NEUTRAL

Brown: LIVE

As the colours of the wires in the mains lead of this apparatus may not correspond with the coloured markings identifying the terminals in your plug, proceed as follows. The wire which is coloured BLUE must be connected to the terminal which is marked with the letter N or coloured BLACK. The wire which is coloured BROWN must be connected to the terminal which is marked with the letter L or coloured RED.

# PX-2 CAUTION-READ THIS FIRST

## Location of installation.

Avoid placing the PX-2 where its total quality will be illaffected, or malfunctions result, from excessive heat (in direct sunlight or near heating equipment), cold, humidity or dust.

## Use of benzene or thinners is to be strictly avoided.

Do not wipe the cabinet with chemical solvents (such as benzene or thinner), or spray aerosol-type insecticides near the machine. Adhesion of benzene, or thinner will cause stains or discolor the cabinet. Be sure not to let record spray reach the cabinet when cleaning discs. Clean only with a soft, dry cloth.

## Handle with care.

Careless handling — knocking against it, dropping something on it — may damage the product and deteriorate performance. Be sure to handle it with care.

## Select a place free of vibrations.

Do not place the PX-2 in locations subject to high vibrations, or close to a speaker system. Select a firm base to place it upon.

## Avoid using an old, worn down stylus.

The service life of a stylus differs according on the condition of discs but, in normal use, a diamond-tip stylus should be replaced after 200 ~ 300 hours of use. Using a worn-down stylus may cause distortion, "scratchness" and damage to discs.

Handle the power cord with care; grasp the plug when removing the cord from the AC outlet socket.

## Place at a sufficient distance from amplifiers.

When installing in parallel with the audio amplifier to which it is to be connected, place the PX-2 so that the tonearm will be as far away as possible from the power transformer side of the amplifier. Also be sure to keep the output cord separated at a distance from the power supply.

## Keep it level.

Speed of revolution and tonearm movement will be adversely affected if the turntable is not properly leveled.

## Moving and transportation.

When it is necessary to move the unit — for example, to change the layout of the listening room — be sure to keep the unit level. If tilted, there is danger of the arm unit slipping out. When transporting it when moving to another house, pack it firmly to protect the arm unit. (Refer to Page 4.)

## If a foreign object falls inside.

The section the tonearm moves over is of an open construction for mechanical reasons: special attention should be paid not to drop any foreign object inside. If something should fall inside, turn off the power switch immediately and remove the object. If it has fallen into an inaccessible place, do not attempt to open the cabinet; instead, contact your local YAMAHA dealer or service representative.

Keep this Owner's Manual in a safe place for future reference.

The voltage selector switch on the cabinet of the PX-2 must be set for your local mains voltage *BEFORE* plugging in the AC main supply. Voltages are 110/120/130/220/230/240 V AC, 50/60 Hz. (General Model Only)

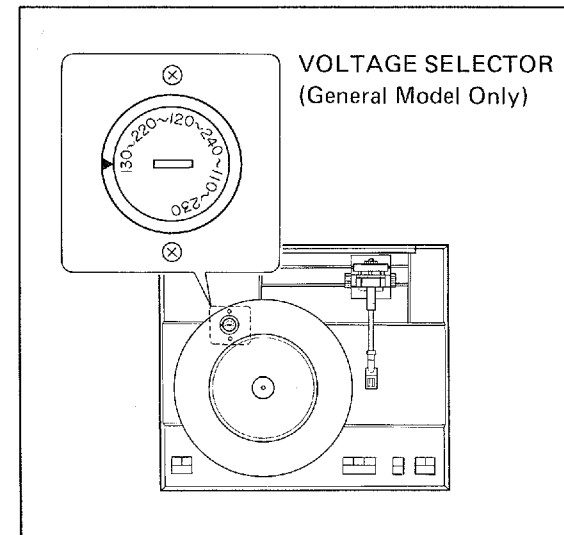

## U.S.A., Canadian and British Models

The following "CAUTION" label is attached to the cabinet.

CAUTION—TO PREVENT ELECTRIC SHOCK, DO NOT REMOVE COVER OR SCREWS. NO USER-SERVICEABLE PARTS INSIDE. PILOT LAMPS SOLDERED IN PLACE. REFER SERVICING TO QUALIFIED SERVICE PERSONNEL. (CS09125)

# PX-2 BEFORE ASSEMBLY AND ACCESSORIES

## Removing the transit screws

The arm unit has been secured with screws on the rear side, and by an arm fixing plate on the front in order to protect the arm unit from vibrations, etc. during transport. Remove the screws and fixing plate before using the PX-2. Keep the screws together with the carton box for future transport.

### 1. Remove the transport fixing plate. (Front side)

When transporting, do not forget to resecure the tonearm. Lower the tonearm unit to its lowest position. Firmly tighten the LOCK  $\Delta$  knob and fix it in position with the arm fixing plate and vinyl string.

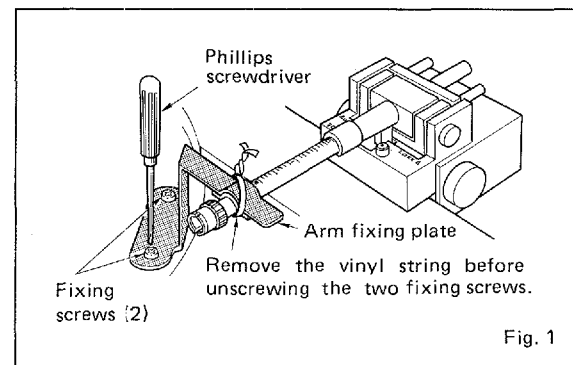

### 2. Remove the three transport fixing screws. (Rear side)

When transporting, do not forget to resecure the arm unit with the fixing screws.

To remove the fixing screws (and also to fix the arm unit for re-transport), raise the rear side of the unit.

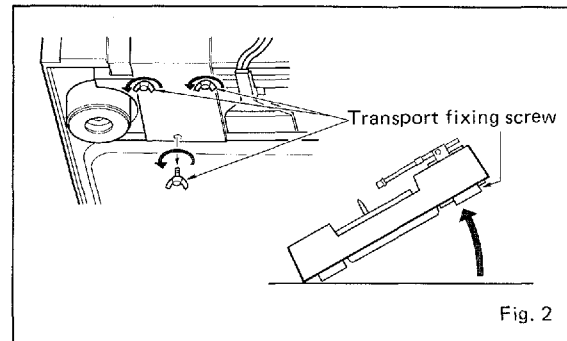

## How to fix the arm unit for transport

When it is necessary to transport the unit, the arm unit should be fixed without fail in the following sequence to protect the arm unit. Failure to secure the arm unit when the unit is to be transported may lead to disorders.

1. After moving the tonearm to the extreme right, disconnect power. Then, remove the platter, headshell, dust cover and main weight.
2. Referring to Fig. 2, fix the arm unit in place with the three transport fixing screws.
3. Referring to Fig. 1, fix the tonearm in place with the arm transport fixing plate.

\* Be careful not to over-tighten the fixing screws.

## Accessories

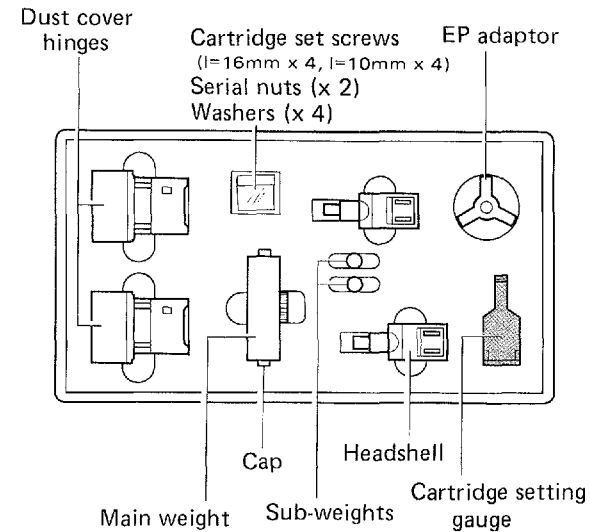

# PX-2 ASSEMBLY AND CONNECTIONS

## Mounting the platter

1. Hold the platter as illustrated in Fig. 3 and fit it gently onto the center shaft.
2. Place the rubber mat over the platter.

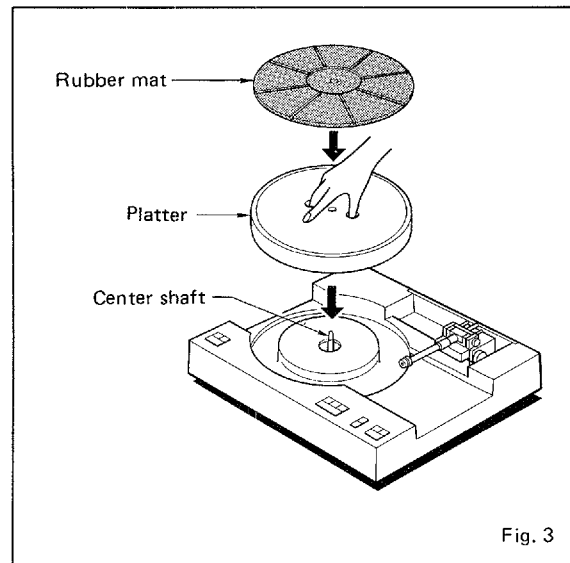

Fig. 3

## Fitting of cartridge

The head shell of the PX-2 permits attachment cartridges within 5~11g without using sub-weights. When fitting the cartridge onto the head shell, connect the lead wires of the head shell to the pins of the cartridge correctly.

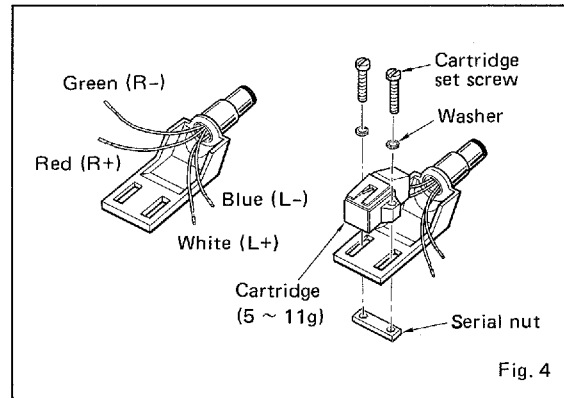

Fig. 4

- Cartridges in the weight range of over 11g up to 16g can be used by removing the left and right caps of the main weight as shown in Fig. 5 and fitting on the supplied sub-weights.

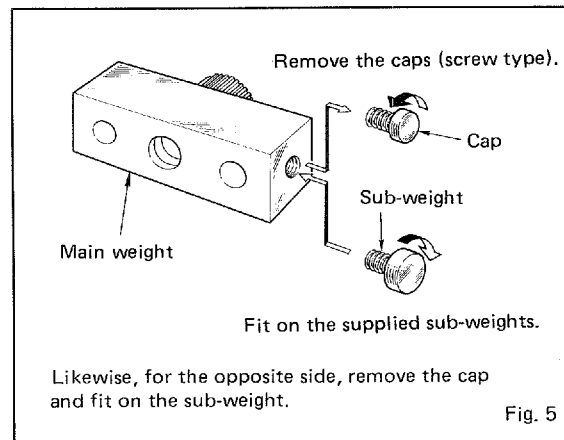

Fig. 5

- Do not use cartridges weighting over 11g without using the sub-weights as it will cause damage to the stylus tip and disc.
- When using a head shell other than the one provided as standard accessory, or a cartridge integrated with a head shell that is provided with a finger hook may come in contact with the dust cover. If such is the case, replace the head shell with the standard one, or use it with the finger hook disconnected.

## Position to fit cartridge

The cartridge fitting position is determined by placing a setting gauge against the cartridge as shown in Fig. 6 and matching the stylus point of the cartridge with the STYLUS POINT marking on the gauge. Firmly fix the cartridge in position.

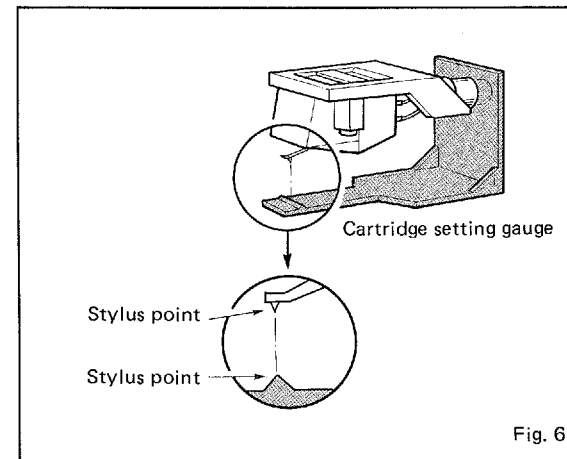
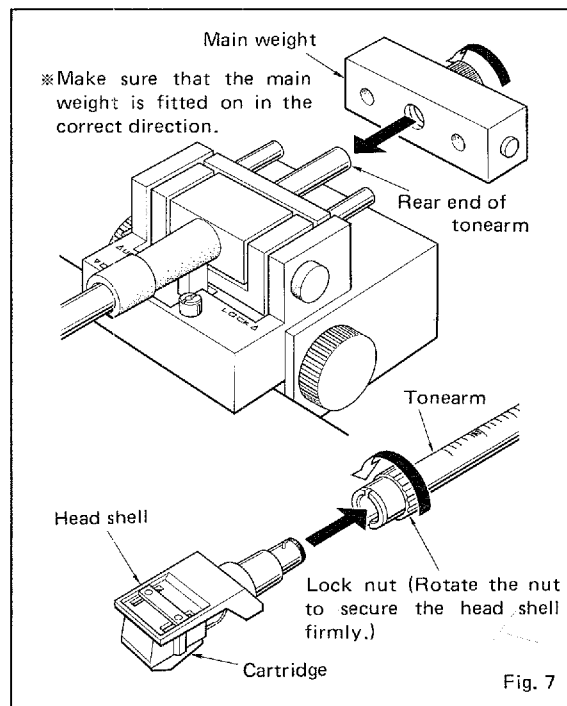

Fig. 6

When fitting on the cartridge, confirm, by viewing the cartridge from the front, that the cartridge is properly centered with the head shell. Otherwise, the tonearm may descend to an incorrect position when searching out the beginning of a program.

### Assembling the tonearm

1. Push the main weight into the tonearm from the rear, while turning the black knob of the main weight in the direction of the arrow as shown in Fig. 7.
2. After the spiral grooves cut inside the main weight engage with the click stopper on the rear of the tonearm, the main weight will move forward smoothly when further turned counter-clockwise (toward the left when viewed from the front of the tonearm), and backward, when turned clockwise (to the right).
3. With the projected pin facing upward, insert the head shell fitted with the cartridge into the lock nut on the forward end of the tonearm. Rotate the lock nut to secure the head shell firmly.



### Attaching the dust cover

1. Insert the dust cover hinges into the left and right receptacles provided on the rear of the cabinet. (Arrow ① )
2. Next, insert the two recessed portions of the dust cover's rear surface into the hinges. (Insert both left-and right-side hinges together at the same time.) (Arrow ② )
3. The dust cover can be freely detached or attached. To remove it, reverse the procedure outlined above.

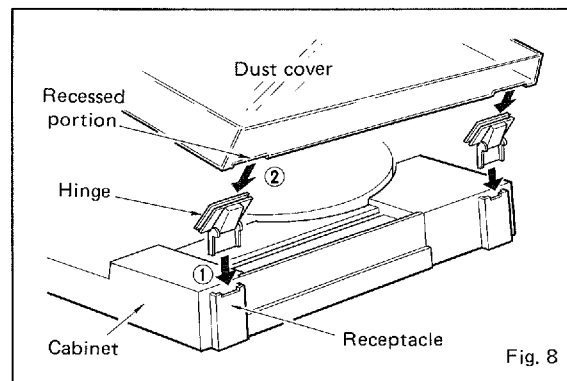

### Insulator height adjustment

This unit weighs 17 kg. It is necessary, therefore, to install it on a firm base or table. After placing it on the base or table, adjust the height of the insulators to properly level the unit.

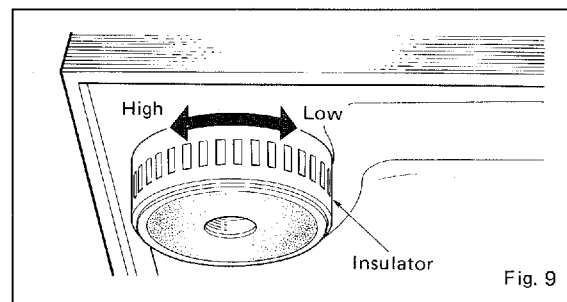

### Connections

After completing assembly of the platter and tonearm, follow the directions given below to connect the amplifier.

1. Connect the output cord leading out from the cabinet's rear to the PHONO terminal of the audio amplifier. Do not mistake the L (Left channel) for the R (Right channel). The white one is L and the red R. (Fig. 10)
2. Connect the black ground wire leading out from the output cord to the GND terminal of the audio amplifier. Depending on the type of the amplifier, however better results with regard to hum noise may sometimes be obtained if the ground wire is not connected. Choose whichever of the two that results in less hum.
3. Connect the power cord to an AC wall outlet, or a spare power supply socket (AC outlet) in the audio amplifier.

\* When the power plug of this unit is connected to a spare "SWITCHED" power supply socket of the amplifier, the power switch of the amplifier will be interlocked with the switch of this unit, permitting simultaneous POWER-ON. (In this case, the power switch of this unit should be kept switched on.)

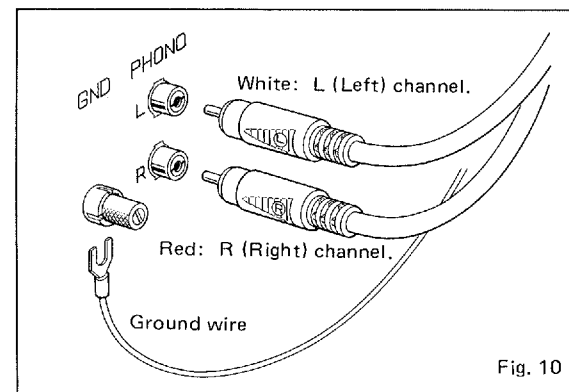

# PX-2 IDENTIFICATION AND FUNCTIONS OF CONTROLS

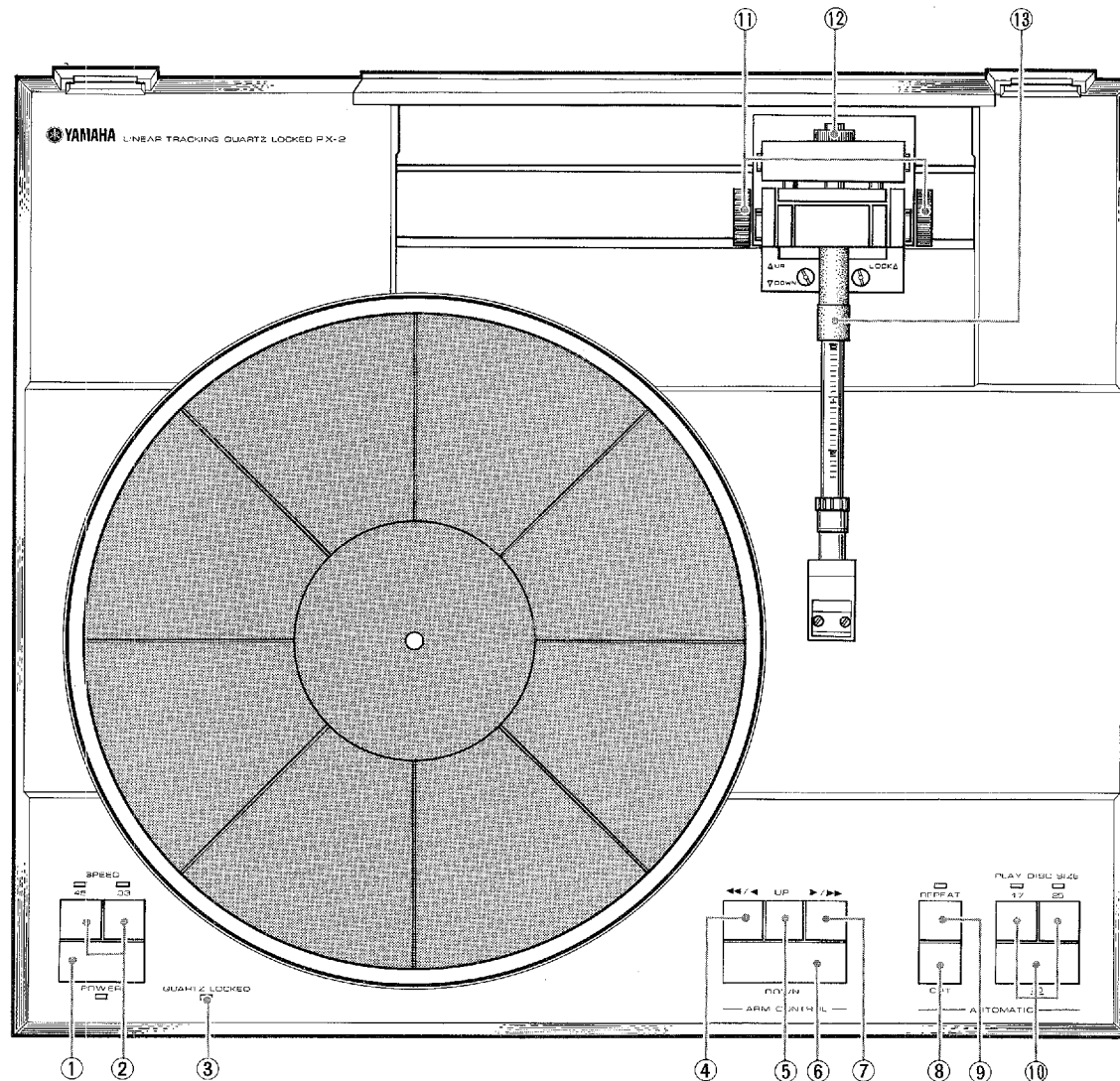

## ① POWER (Power Switch)

When this switch is depressed, power will be switched on, and the LED (indicator) beneath the switch will light on. To disconnect power, depress this switch again.

## ② SPEED (Speed Changing Switch)

This switch functions to change the speed of the platter.

- When a 33-1/3 r.p.m. disc is to be played, depress the "33" switch. The "33" indicator will illuminate.
- When playing a 45 r.p.m. disc, depress the "45" switch. The "45" indicator will illuminate.
- \* When power is switched on, the speed is automatically set to 33 r.p.m.

## ③ QUARTZ LOCKED (Quartz-Locked Indicator)

This indicator shows that the platter has attained stable rotation (for either 33-1/3 or 45 r.p.m.) and the quartz PLL mechanism has gone into the locked condition.

## ARM CONTROL (MANUAL)

## ④ ◀◀/◀ (Leftward Feed Switch for Tonearm)

The tonearm will be fed toward the left for the duration this switch is being depressed. When this switch is slightly depressed, the tonearm will move slowly, whereas, when depressed to a further depth, the tonearm will move quickly.

- \* When the tonearm has moved to the extreme left, no matter whether the switch is depressed or not, the arm will not make any further leftward movement.

#### ⑤ UP (Cueing-UP Switch)

Depress this switch to discontinue play temporarily. The tonearm will be lifted, removing the stylus tip from the disc surface.

#### ⑥ DOWN (Cueing-DOWN Switch)

Depress this switch to start play midway on a disc. The tonearm will lower itself, bringing the stylus tip in contact with the disc surface.

\* When the UP switch, or DOWN switch is depressed, you will hear click. This is neither an abnormal noise, not an indication of disorder, but a sound produced by the operating solenoid for cueing. Be careful not to depress the UP switch while the tonearm is descending, as it may cause the tonearm to fly when the "click" of the operating solenoid is heard.

#### ⑦ ►/►► (Rightward Feed Switch for Tonearm)

The tonearm will be fed toward the right for the duration this switch is being depressed. When this switch is slightly depressed, the tonearm will move slowly, whereas, when depressed to a further depth, the tonearm will move quickly.

\* The tonearm will come to a halt once it reaches the extreme right, and the platter will stop rotating.

### AUTOMATIC PLAY

#### ⑧ CUT (Play Discontinuing Switch)

Whenever this switch is depressed, the tonearm will start RETURN movements, whatever operation mode it may be in.

#### ⑨ REPEAT (Repeat Switch)

Repeat play is possible by depressing this switch, in line with the disc play controlled by the PLAY/DISC SIZE switch (⑩).

During REPEAT play, the indicator located above the switch will illuminate. To end REPEAT play, depress this switch once again.

\* For performances initiated with the ARM CONTROL switches (④ through ⑦), REPEAT play is not possible even when this switch is depressed.

#### ⑩ PLAY/DISC SIZE (Disc Size Switch)

This switch makes possible automatic play, by selecting the disc size (17 cm, 25 cm or 30 cm). When any one of the switches is depressed, the indicator of the selected size will illuminate, and the whole process from the starting of platter, arm feed, cueing-DOWN, play, auto-return to stop will be automatically performed.

\* Be careful not to make a mistake in selecting the disc size; damage to the cartridge and stylus tip may result when the wrong disc size is selected.

\* When any one of the ARM CONTROL switches (④ through ⑦) is depressed, automatic play will be completely released.

#### ⑪ Arm Height Adjusting Knob

After loosening the lock control provided on the right-side of the tonearm, adjust the arm height, using the left-side Δ UP and ▽ DOWN controls. On completion of adjustment, lock the arm firmly by means of the LOCK Δ control.

#### ⑫ Main Weight & BALANCE Control Knob

This control functions to balance the tonearm. When the control is turned counterclockwise (leftward) as viewed from the front of the tonearm, the main weight will move forward, and when the control is turned clockwise, the main weight will move backward.

#### ⑬ Tracking Force Adjusting Weight

This determines the tracking force. Tonearm balance adjustments are performed by matching the forward end of the weight with the "0" line. (The forward end of the weight will be the basic line used for determining the tracking force.)

# PX-2 ADJUSTING THE TONEARM

Tonearm adjustment should be carried out in the order shown below.

1. Adjusting tonearm balance → 2. Adjusting cartridge tracking force → 3. Adjusting tonearm height

## Adjusting tonearm balance

Once the cartridge is fitted on and the tonearm assembled, proceed with balance adjustment as described below:

1. Match the forward end of the tracking force adjusting weight with the "0" line (the farthest position) of the tonearm. Ready the tonearm as if for "Play", by removing the cover of the stylus of the cartridge, for example.
2. Switch on the power switch, and then depress the CUT switch. After confirming that the tonearm is at the check right, depress the DOWN switch of the ARM CONTROL and examine the level balance of the tonearm. When the head shell side is too high, the tonearm's head section

will sink, whereas, when the main weight side is too heavy, the tonearm's head section will rise.

3. With the left hand gently applied to the head shell, revolve the balance control of the main weight to attain perfect balance.
4. When steady balance has been attained, depress the UP switch.

## Adjusting Cartridge Tracking Force

Adjusting cartridge tracking force is to be performed only after the tonearm has been properly balanced.

1. Do not change the main weight's position from where it gives perfectly leveled balance.
2. The scale engraved in the tonearm is graduated in units of 0.1 g. Match the forward end of the tracking force adjusting weight to the position on the cartridge that corresponds to the optimum tracking force for that cartridge.

**NOTE:** Use the tracking force adjusting weight with its flat surface facing downward.

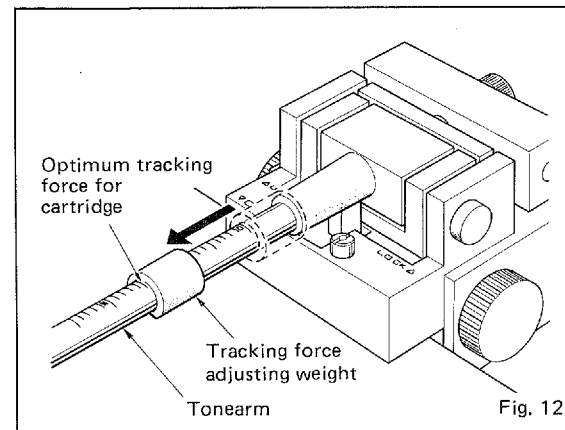
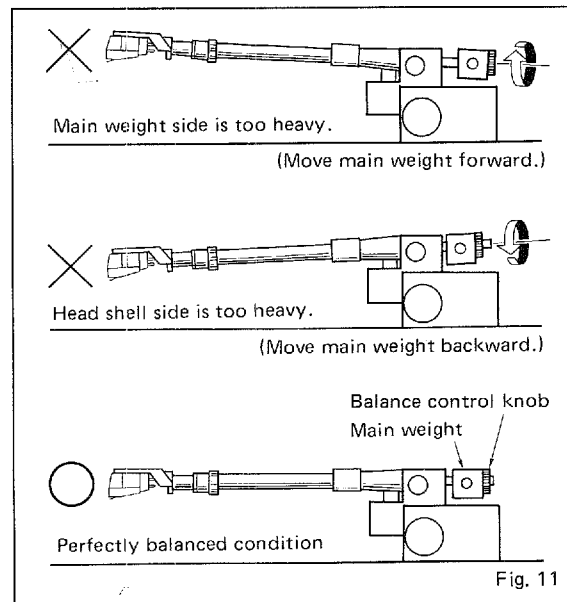

## Adjusting Tonearm Height

1. Loosen the LOCK  $\Delta$  knob.
  2. As if to ready the cartridge for "Play", for example, remove the stylus tip cover.
  3. Place a disc on the turntable. Depress the PLAY/DISC SIZE switch to lower the stylus onto the disc surface.
  4. Make sure that the record surface is parallel with the tonearm pipe, by adjusting the  $\Delta$  UP and  $\nabla$  DOWN knob.
  5. When proper height adjustment has been attained, firmly tighten the LOCK  $\Delta$  knob, with the tonearm position unchanged.
- \* Carry this adjustment out very carefully, so that neither stylus nor disc are damaged.

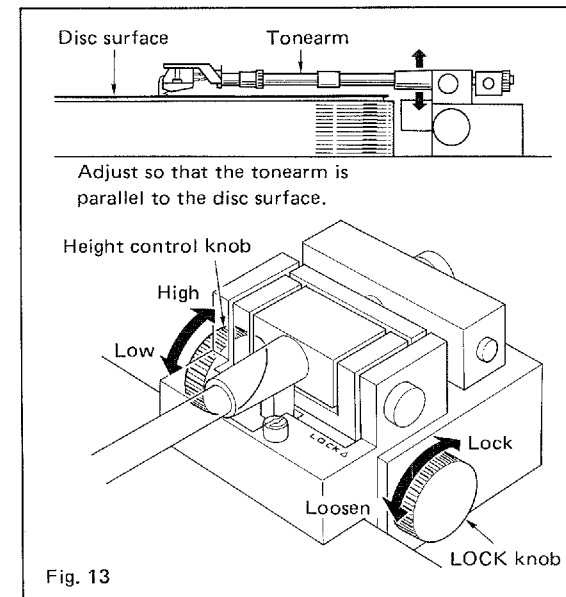

# PX-2 HOW TO PLAY DISCS

Before starting disc play, check and confirm proper connection of power plug, output cord and ground wire.

## Automatic Disc Play

1. Turn on the POWER switch and place a disc on the platter.
2. Match the platter speed to the disc speed.  
(As the turntable will be automatically set to "33" r.p.m. when power is turned on, the "45" button of the SPEED switch should be depressed when a 45 r.p.m. disc is to be played.)
3. Matching it with the size of the disc, depress the PLAY/DISC SIZE button of that particular size.

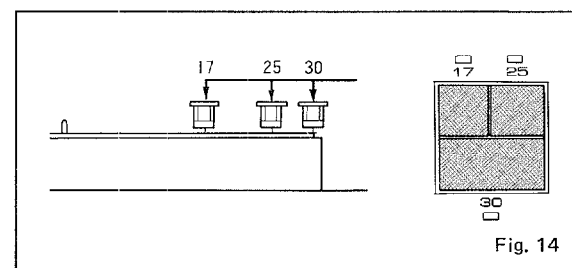

This will cause the DISC SIZE indicator to light up. The platter will start rotating and the tonearm will move up to the prescribed AUTO-LEAD-IN position\* at which it will descend to start disc play. (AUTO-LEAD-IN)

4. When disc play is finished and the tonearm enters the LEAD-OUT groove on the innermost side of the disc, the tonearm will rise and return to the extreme right, causing the platter to stop at the same time. (AUTO-RETURN)

### "Prescribed position"

The AUTO-LEAD-IN position is set according to RIAA — specified records, the position at which the stylus will lower itself may not match discs that do not conform to RIAA.

## For REPEAT Play

Start REPEAT play by depressing the PLAY/DISC SIZE switch and then depressing the REPEAT switch.

REPEAT play will start at the correct position for the selected size. Likewise, on completion of disc play, the disc, through AUTO-RETURN, will return to this position, and play will be repeated. To release REPEAT play, depress the REPEAT switch once again. This will cause the indicator to go out and the REPEAT play mechanism to be released. Thus, on completion of disc play, play will be discontinued, following AUTO-RETURN of the tonearm.

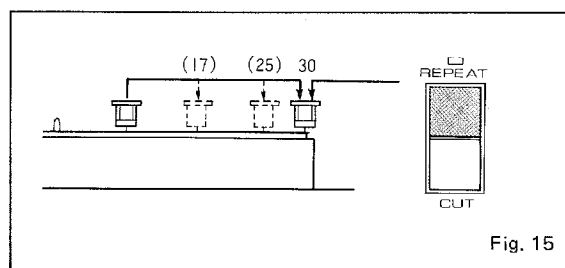

## When a wrong disc size has been selected

Immediately depress the switch corresponding to the proper size. This will cause the tonearm to be transported to the position of the newly selected disc-size to start play. Another method to correct the mistake is to depress the CUT switch first and then depress the proper disc-size switch.

\* If, for example, a 17 cm disc is placed on the platter but the 30 cm disc-size switch has been depressed by mistake, it will cause damage to the cartridge and stylus tip. So be extremely careful not to misoperate the size switches.

## When you wish to skip a portion of music

1. Depress the UP switch of the ARM CONTROL. The tonearm will rise.
  2. Depress either the LEFTWARD FEED, or RIGHTWARD FEED switch to move the tonearm to the desired position. The speed of the tonearm movement can be controlled in two steps. This permits fine regulation of the stylus descending position.
  3. Depression of the DOWN switch will cause the tonearm to descend, initiating disc play. On completion of the music, the tonearm will return automatically to complete operation.
- \* When the ARM CONTROL switch is depressed during disc AUTO-PLAY, will be released, and REPEAT-PLAY will be released at the same time if it has been selected.

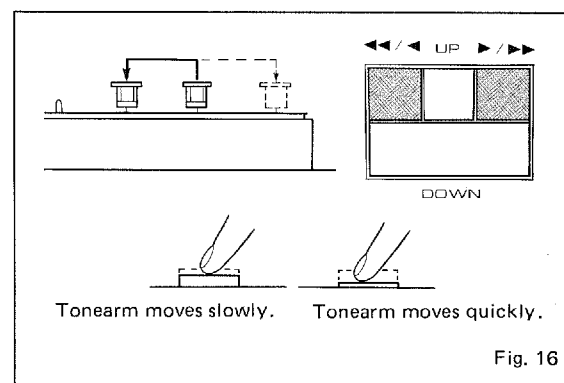

# PX-2 SPECIFICATIONS

## When play is to be started midway in disc

1. Move the tonearm to the desired position, using the LEFTWARD FEED switch. This will cause the platter to start rotating.
  2. Depress the DOWN switch to lower the tonearm to start disc play.
  3. On completion of disc play, operations will be completed, following AUTO-RETURN of tonearm.
- \* REPEAT play is not possible when play has been started with manual operation.

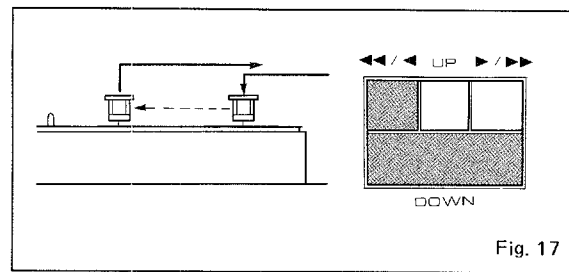

Fig. 17

## When disc play is to be discontinued midway in play

Depress the CUT switch. Play will be discontinued at that position. Following AUTO-RETURN of tonearm, operation will be completed.

- \* To protect the cartridge should power supply be discontinued because of service interruption during disc play, or should the power switch be switched off by mistake, the unit has been designed so that the tonearm will stop in an uplifted position. When power supply has been restored, start operation again.

### TONEARM SECTION

Arm type	Linear tracking arm
Servo system	Photo-electric tracking sensor plus servo motor
Total length	236 mm (9-9/32")
Effective length	190mm (7-15/32")
Tracking force device	Static balance type sliding weight system 0 ~ 2.5 g, in 0.1 g steps
Effective mass (In cartridge-less state)	Proportional type to tracking force 1.0 g (Tracking force) 16.5 g 1.5 g (Tracking force) 17.0 g 2.0 g (Tracking force) 17.5 g
Applicable cartridge weight range	5 ~ 11 g (Using sub-weights) 10 ~ 16g
Maximum horizontal tracking error angle	±0.15°
Arm lifter	At stylus tip ±0.5 mm
Adjustable range of arm height	Oil damp type cueing ±4.0 mm
Head shell	Pure, forged aluminum, Weight: 8.0 g Plug-in type conforming to EIA Standards
PU Cable	NEGLEX 2496 Low-impedance, double cylindrical cord Capacitance: 130pF Resistance: 1 Ω
Cartridge (Not provided)	Replaceable

### ROTARY SECTION

Motor	DC, 4-phase, 8-pole coreless Hall motor
Starting torque	1 kg-cm, or more
Drive system	Direct drive
Servo system	Quartz PLL, Negative/positive two-direction servo
Locking torque	450 g-cm
F.G.	Total circumference integrating type
Speed (With Lock Indicator)	33-1/3 r.p.m., 45 r.p.m.
Platter	31 cm (12-1/4") diameter, aluminum die-cast Weight: 2.1 kg (4.62 lbs) (including rubber mat)
Moment of inertia	270 kg-cm <sup>2</sup> (Including rubber mat)

### EXTERNAL DESIGN

Cabinet	Aluminum, die-cast, 5mm thick black enamel coating
Dust cover	Acrylic, 5mm thick, weighing 1.3kg Front operating type.
Hinges	Free stop, detachable type
Insulator	Combination of spring-and -rubber type with height adjustment

### CONTROL SECTION

Automatic functions	AUTO-LEAD-IN AUTO-RETURN REPEAT AUTO-UP (During Power-OFF)
Size selector	17/25/30 cm (7"/10"/12")
Manual functions	ARM-UP ARM-DOWN LEFTWARD & RIGHTWARD 2-speed feeding CUT
Speed	33-1/3 r.p.m. and 45 r.p.m.
Others	Power switch

### GENERAL

S/N ratio	80dB (IEC 98A Weighted)
Wow and flutter	0.01% WRMS (FG direct)
Power supply and consumption	
U.S.A & Canadian Models	120V AC, 60Hz ... 25W
European Model	220V AC, 50Hz ... 25W
Australian & British Models	240V AC, 50Hz ... 25W
General Model	110/120/130/220/230/240V AC, 50/60Hz ... 22W
Dimensions (W x H x D) mm	493 x 156 x 428 (19-7/16") x (6-5/32") x (16-27/32")
Total weight	17 kg (37.4 lb)

Specifications are subject to change without notice.

# PX-2 TROUBLE SHOOTING

If your PX-2 ceases to function normally, check the following trouble shooting list. Only if this fails to restore normal operation should you contact your local YAMAHA dealer or service representative.

Fault	Cause	Cure
Power does not turn on when POWER switch is depressed.	Power cord not completely inserted into wall AC outlet, or amplifier's spare power supply socket.	Re-insert cord into wall AC outlet, or amplifier's spare power supply socket.
Balance (zero) cannot be obtained after changing cartridge.	Cartridge is either too heavy, or too light.	The PX-2 handles cartridges in the weight range of 5g ~ 11g: the sub-weights are not needed. When a cartridge of over 11g is to be used, fit on the sub-weights and perform readjustment.
REPEAT play cannot be effected.	PLAY has been started manually. Has been manually operated during AUTO-PLAY.	First depress PLAY/DISC SIZE button and then depress REPEAT button.
No sound is heard, or sound is too faint although the stylus descends on the disc surface.	Defective contact of head shell connector. Amplifier's FUNCTION switch is not positioned to PHONO. Amplifier's volume is turned down. Insufficient contact of turntable output cord.	Attach head shell to the tonearm properly. Set FUNCTION properly to PHONO. Turn up the volume to an adequate level. Check and correct connector terminals between amplifier and rear panel.
The body of the cartridge catches on the disc surface.	Too heavy cartridge stylus tracking force. Inadequate tonearm height.	Readjust tracking force to optimum. Adjust to proper tonearm height.
Unpleasant, distorted reproduced sound, with clicking or crackling sounds. High frequency reproduction is particularly affected.	Turntable is slanted and not properly leveled. Dust accumulating on the stylus tip. Stylus tip is worn down. The disc itself is damaged or is dirty. Stylus tracking force is either too light or too heavy. Amplifier's treble response has been overemphasized.	Correct by leveling turntable properly. Clean stylus tip using special stylus cleaning brush. Replace the stylus. Replace with a new disc. Readjust the tracking force for the cartridge to the recommended value. Turn the treble control back to the flat position.
Unpleasant reproduced sounds with howling (droning) noise.	Turntable is installed too close to the speaker system, or resonance has been induced by vibrations because placement of turntable is unstable.	Move turntable to a stabler place, or install it farther away from the speaker. (Installation in a corner of a room should be avoided in particular.)
Inclusion of humming noise during disc play.	Ground wire of turntable not connected to amplifier's GND terminal. Defective contact of head shell connector.	Connect ground wire to GND terminal. (In some cases, it is better not to ground it.) Fit the head shell onto the tonearm correctly.

# PX-2 BLOCK DIAGRAM

## TONEARM CONTROL CIRCUIT

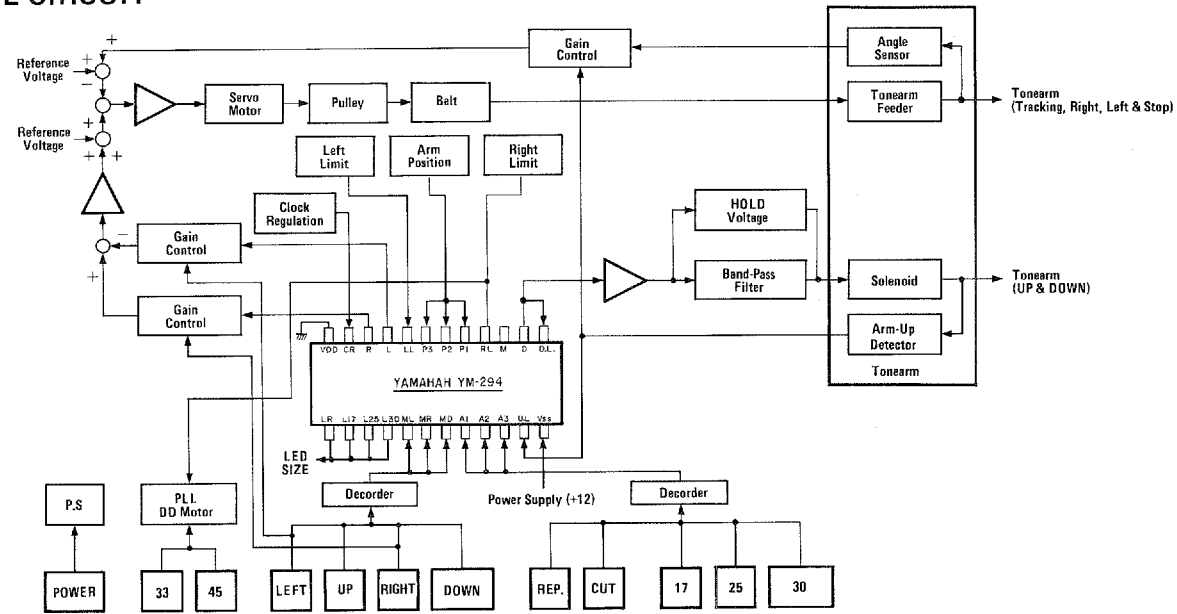

## DC MOTOR SERVO CIRCUIT

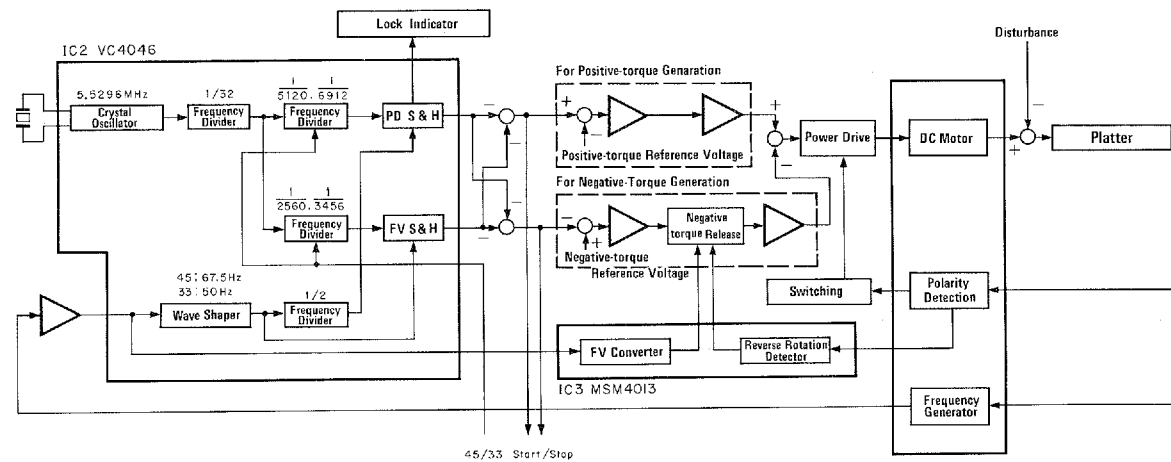

# PX-2 SCHEMATIC DIAGRAM

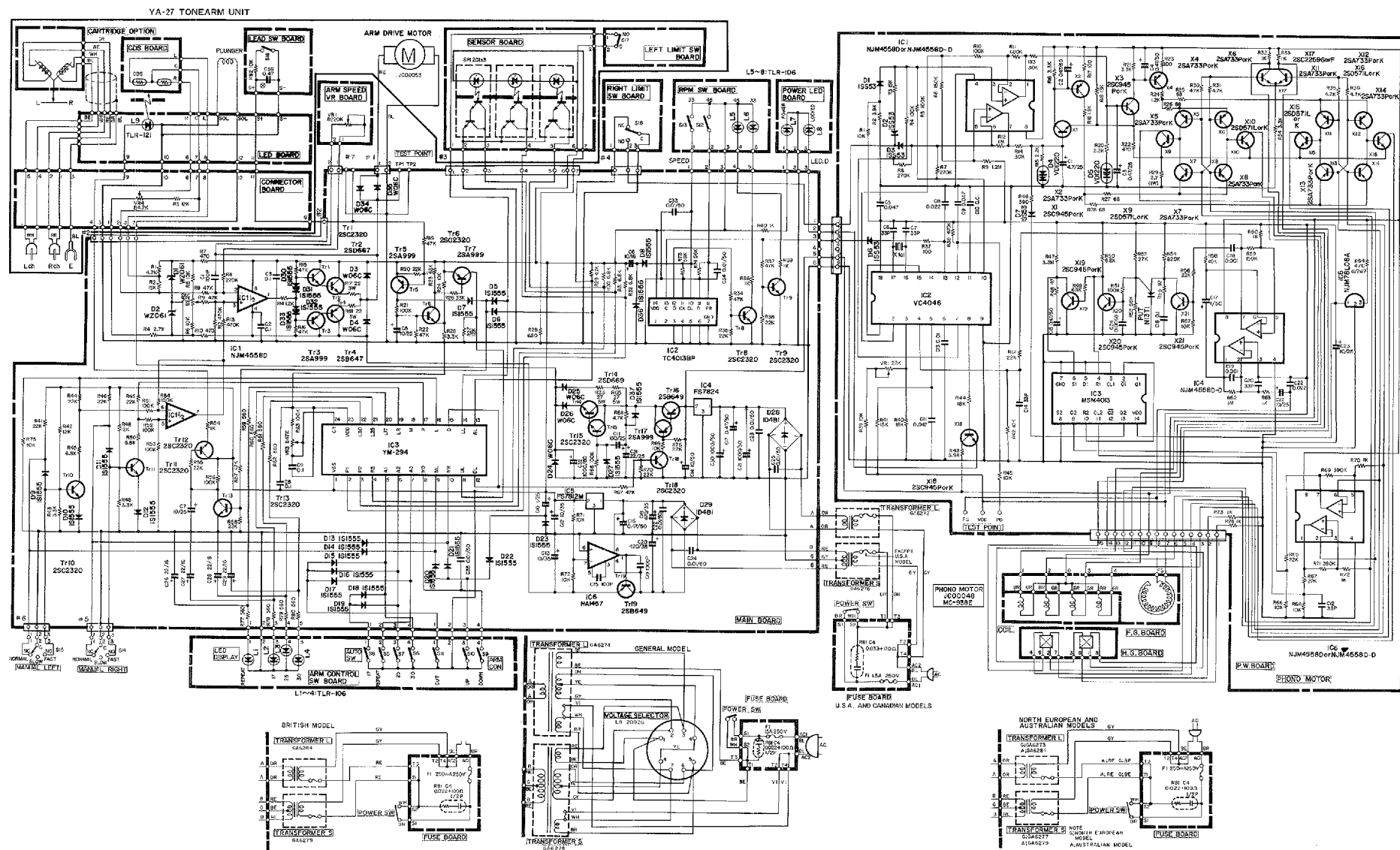

SINCE 1887  **YAMAHA**  
NIPPON GAKKI CO., LTD. HAMAMATSU, JAPAN