

# YAMAHA A-1000

*Natural Sound Stereo Integrated Amplifier*

*Auto Class A Power Output*

*Zero Distortion Rate Amplification in Power and EQ Stages*

*Extended Rolloff Equalizer and Pure Current Dam*

*Direct MC Cartridge Connection and Selectable Cartridge Impedance*

*Main Direct Switch, Rec. Out, Continuously Variable Loudness Control*

*Thank you for purchasing the YAMAHA A-1000 stereo integrated amplifier.*

## CONTENTS

CAUTION . . . . .	1/2
CONNECTION DIAGRAM . . . . .	3
CONNECTIONS . . . . .	4
FRONT PANEL PARTS AND FUNCTIONS . . . . .	5/6/7/8
TROUBLESHOOTING . . . . .	9
BLOCK DIAGRAM . . . . .	10
SPECIFICATIONS . . . . .	11

## OWNER'S MANUAL



### IMPORTANT

Please record the serial number of your unit in the space below.

Model: A-1000

Serial No.:

The serial number is located on the rear of the chassis.

Retain this Owner's Manual in a safe place for future reference.

### WARNING

To prevent fire or shock hazard, do not expose this appliance to rain or moisture.

## CAUTION (PREPARED IN ACCORDANCE WITH UL STANDARD 1270)

- 1** Read Instructions — All the safety and operating instructions should be read before the appliance is operated.
- 2** Retain Instructions — The safety and operating instructions should be retained for future reference.
- 3** Heed Warnings — All warnings on the appliance and in the operating instructions should be adhered to.
- 4** Follow Instructions — All operating and other instructions should be followed.
- 5** Water and Moisture — The appliance should not be used near water — for example, near a bathtub, washbowl, kitchen sink, laundry tub, in a wet basement, or near swimming pool, etc.
- 6** Carts and Stands — The appliance should be used only with a cart or stand that is recommended by the manufacturer.
- 7** Wall or Ceiling Mounting — The appliance should be mounted to a wall or ceiling only as recommended by the manufacturer.
- 8** Ventilation — The appliance should be situated so that its location or position does not interfere with its proper ventilation. For example, the appliance should not be situated on a bed, sofa, rug, or similar surface that may block the ventilation openings; or placed in a built-in installation, such as a bookcase or cabinet that may impede the flow of air through the ventilation openings.
- 9** Heat — The appliance should be situated away from heat sources such as radiators, stoves, or other appliances that produce heat.
- 10** Power Sources — The appliance should be connected to a power supply only of the type described in the operating instructions or as marked on the appliance.
- 11** Power-Cord Protection — Power-supply cords should be routed so that they are not likely to be walked on or pinched by items placed upon or against them, paying particular attention to cords at plugs, convenience receptacles, and the point where they exit from the appliance.
- 12** Cleaning — The appliance should be cleaned only as recommended by the manufacturer.
- 13** Nonuse Periods — The power cord of the appliance should be unplugged from the outlet when left unused for a long period of time.
- 14** Object and Liquid Entry — Care should be taken so that objects do not fall into and liquids not spilled into the inside of the appliance.
- 15** Damage Requiring Service — The appliance should be serviced by qualified service personnel when:
  - A. The power-supply cord or the plug has been damaged; or
  - B. Objects have fallen, or liquid has been spilled into the appliance; or
  - C. The appliance has been exposed to rain; or
  - D. The appliance does not appear to operate normally or exhibits a marked change in performance; or
  - E. The appliance has been dropped, or the cabinet damaged.
- 16** Servicing — The user should not attempt to service the appliance beyond those means described in the operating instructions. All other servicing should be referred to qualified service personnel.

# A-1000

**CAUTION: READ THIS BEFORE  
OPERATING YOUR A-1000**



**CAUTION**  
**RISK OF ELECTRIC SHOCK**  
**DO NOT OPEN**

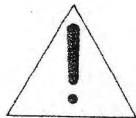

**CAUTION: TO REDUCE THE RISK OF  
ELECTRIC SHOCK, DO NOT REMOVE  
COVER (OR BACK). NO USER-SERVICEABLE  
PARTS INSIDE. REFER SERVICING TO  
QUALIFIED SERVICE PERSONNEL.**

## • Explanation of Graphical Symbols

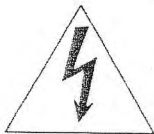

The lightning flash with arrowhead symbol, within an equilateral triangle, is intended to alert you to the presence of uninsulated "dangerous voltage" within the product's enclosure that may be of sufficient magnitude to constitute a risk of electric shock to persons.



The exclamation point within an equilateral triangle is intended to alert you to the presence of important operating and maintenance (servicing) instructions in the literature accompanying the appliance.

1

The A-1000 is a sophisticated integrated stereo amplifier. To ensure proper operating for the best possible operation, please read this manual carefully.

2

Choose the installation of your A-1000 carefully. Avoid placing it in direct sunlight or close to a source of heat. Also avoid locations subject to vibration and excessive dust, heat, cold or moisture. Keep away from such sources of hum as transformers or motors.

3

Do not open the cabinet as this might result in damage to the set or electrical shock. If a foreign object should get into the set, contact your dealer.

4

Do not place records or other objects on top of the amplifier so that the ventilation holes are blocked. This will cause the internal temperature to rise and may result in a failure.

5

When removing the power plug from the wall outlet, always pull directly on the plug; never yank the cord.

6

Do not use force when using the switches and knobs.

7

When moving the set be sure to first pull out the power plug and remove cords connecting to other equipment.

8

Always set the volume controls to "∞" while lowering the tonearm to play a record, then turn the volume up after the stylus is seated in the record groove.

9

Do not attempt to clean the A-1000 with chemical solvents as this might damage the finish. Use a clean, dry cloth.

10

Be sure to read the "troubleshooting" section for advice on common operating errors before concluding that your A-1000 is faulty.

11

Keep this manual in a safe place for future reference.

12

Do not connect audio equipment to the AC outlets on the rear panel if that equipment requires more power than the outlets are rated to provide.



## CONNECTIONS

### • CONNECTING THE SPEAKERS

The matching impedance of this amplifier is 6  $\Omega$ . Either one or two pairs of speakers may be connected. If only one pair is connected, the recommended speaker impedance may be anywhere between 4 and 16  $\Omega$ . If two pairs are connected, however, it is advisable to use speakers with at least an 8  $\Omega$  impedance for optimum performance. Connecting two pairs of 4  $\Omega$  speakers is not recommended.

Connect the cords going to the left speakers to the L terminals and the right speaker cords to the R terminals, making sure that the "+" and "-" marking are observed. If the "+" and "-" wires are reversed at either speaker, the sound will be unnatural and will lack bass. Speaker cords should be cut as short as possible; do not coil up excess wire on the floor. Also, do not bundle with cords from other system components.

Strip about 1cm insulation from the ends of the speaker cords. Loosen the speaker terminal knobs, insert the exposed wire of the speaker cord into the hole and then tighten up the speaker terminal knobs.

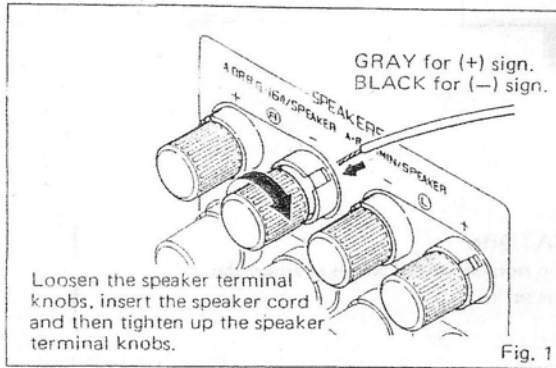

### • CONNECTING THE TURNTABLE

Either an MM cartridge or an MC cartridge may be used with the Phono 1 jacks. Set the front panel Phono Selector switch to correspond to the type of cartridge used. In addition, the cartridge load impedance may be selected for MM cartridges.

Only an MM cartridge should be used with the Phono 2 jacks. The cartridge load impedance is preset at 47 k-ohms, 220 pF.

Plug your turntable into the appropriate jacks and connect the turntable's ground wire to the Gnd terminal. Normally, connecting the ground wire results in minimum hum, but in some cases better results are obtained with the ground wire disconnected. The cartridge and the turntable's output cords should be positioned well away from sources of hum as power cords or power transformers of other system components.

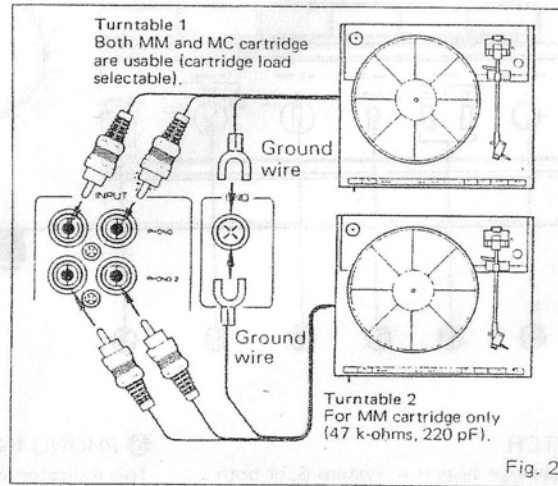

### • CONNECTING A TUNER

Connect cords from the tuner's output jacks to the Tuner jacks of the amplifier. As the amplifier's power supply may generate a certain amount of radio frequency noise, position the tuner so that its AM antenna is well away from the amplifier.

### • CONNECTING TO THE AUX AND DAD JACKS

The Aux and DAD terminals can be used for connecting additional equipment such as a second tuner, a digital audio disc, etc. Note that a turntable cannot be connected to the Aux jacks as there is no RIAA equalization.

### • CONNECTING A TAPE DECK

Connect the tape deck's Line In jacks to the amplifier's Tape 1 Rec Out jacks, verifying that left and right are not reversed. Then, connect the deck's Line Out jacks to the amplifier's Tape 1 Tape PB jacks.

A second deck may be connected to the Tape 2 jacks if desired.

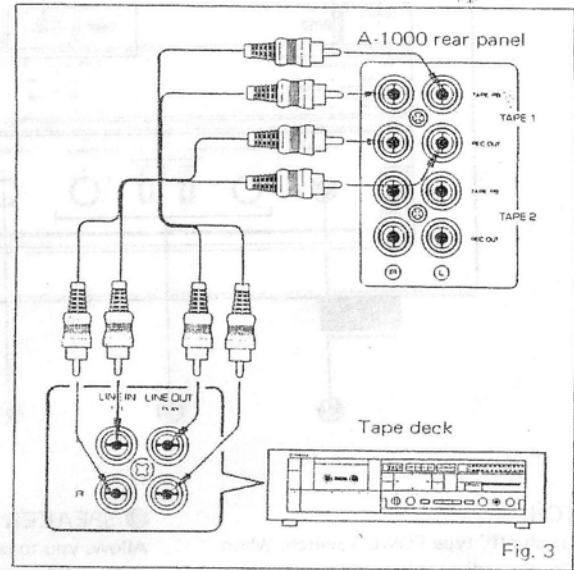

### • AC OUTLETS

For your convenience, the A-1000 provides 3 AC outlets (2 switched and 1 unswitched) on the rear panel. Be sure not to connect appliances to totaling more than 200 watts to the 2 switched outlets or more than 200 watts to the unswitched outlet.

# A-1000

## FRONT PANEL PARTS AND FUNCTIONS

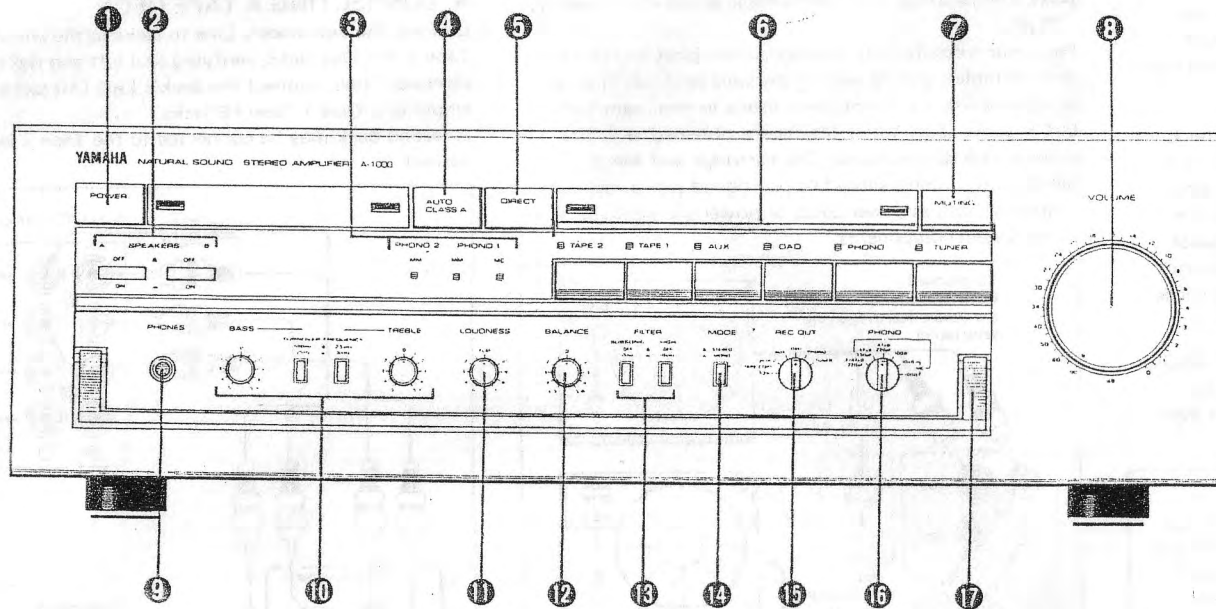

### ❶ POWER SWITCH

This is a "push-on, push-off" type POWER switch. When POWER is pushed on, the indicator lamp corresponding to the selected input source will light.

- \* Before pushing power on, set the volume to its lowest (extreme counter-clockwise) position to prevent any loud power-on noise from occurring.
- \* No sound will be heard from the speakers for several seconds after power is pushed on because the speaker protection circuit is activated.

### ❷ SPEAKER SWITCH

Allows you to select speaker system A, system B, or both at once. When listening to headphones only, turn both A and B off.

### ❸ PHONO INDICATORS

This indicator lights to remind you of which position the PHONO selector ❶ is set to.

## 4 AUTO CLASS A (OPERATION SWITCH)

When the switch is in the OFF position, this unit operates as CLASS AB, however, when the switch is in the ON position (left indicator lights up) the operation automatically switches between CLASS A AND CLASS AB.

\* During CLASS A operation there is a greater than normal flow of idling current than for CLASS AB operation even when there are no signals, and because of that together with temperature increases in the set, careful consideration should be given to provide ventilation to release this heat during operation.

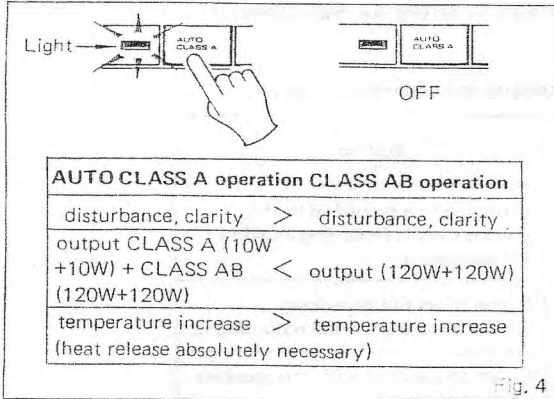

## 5 DIRECT SWITCH

Pressing this switch lights the right indicator and shortens the signal path so that only the DC flat and DC power amp (and the phono equalizer on Phono) are in use. This ensures that the effect on your music of the amplifier circuitry and switch contacts will be minimal, but has the drawback that none of the following controls are active:

- Bass and Treble Controls
- High Filter Switch
- Loudness Control

When none of these controls are being used it is desirable to turn on the Direct switch from the point of view of music reproduction accuracy, but remember to turn it off again before adjusting these. Note that the Direct switch can also be used as a convenient way of disabling all the tone controls at once to check their total effect on the sound.

## 6 INPUT SELECTOR SWITCH

Selects the program source to be listened to.

## 7 MUTING SWITCH

Pressing this switch lights the left indicator and lowers the volume level by 20 dB. Pressing the switch again extinguishes the indicator and restores normal volume. This switch is very convenient for lowering the volume temporarily (for instance, to answer a phone call) without disturbing the original volume setting. Also, when listening at low volume levels, turning on Muting makes it easier to control fine gradations of volume.

\* Turning the Muting switch off when the volume is Turned up could result in a very loud volume that could damage your speakers.

## 8 VOLUME CONTROL

Used to adjust overall sound volume.

## 9 PHONES JACK

Used for plugging in headphones. When it is desired to listen to headphones only, Speaker switches A and B should both be set to the Off ( ) position.

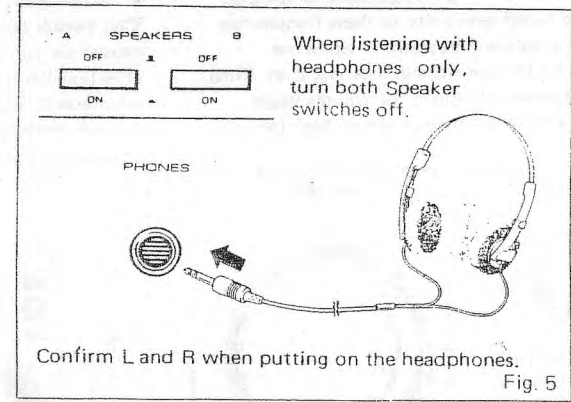

## 10 BASS AND TREBLE CONTROLS

The bass control provides turnover frequencies of 125 Hz and 500 Hz. Turning the Bass control with turnover set to 500 Hz will create a bold change in bass response; with the turnover set to 125 Hz the effect will be much less apparent. Flat bass response is produced at the center "0" position. The treble control provides turnover frequencies of 2.5 kHz and 8 kHz. Turning the Treble control with turnover set to 2.5 kHz will cause a pronounced change in treble response; with the turnover set to 8 kHz the effect will be more delicate. Flat treble response is produced at the center "0" position.

# A-1000

## 11 LOUDNESS CONTROL

Boosts the extreme low and high frequencies to compensate for our ear's reduced sensitivity to these frequencies at low volume. Set it to the Flat position while the Volume control is set to your normal listening level. Turning it counter-clockwise will reduce the volume while retaining the natural balance of the low and high frequencies.

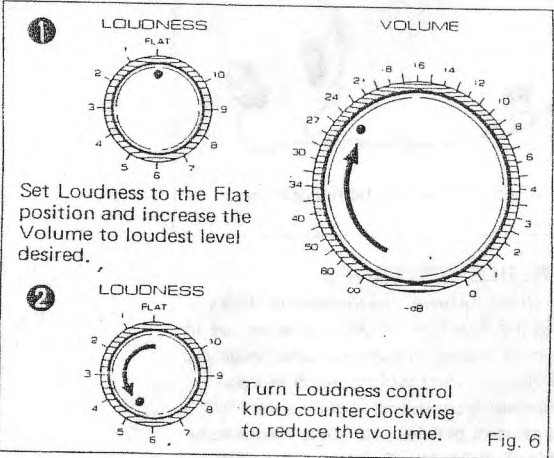

## 12 BALANCE CONTROL

This control lets you adjust the relative volume of the left and right speakers, enabling you to compensate for unbalance caused by installation locations of the speakers and furniture arrangement.

## 13 FILTER SWITCHES

### • SUBSONIC FILTER

This switch lets you cut out ultra-low-frequency signals caused by turntable rumble or warped records without affecting the quality of audible sounds. These subsonic interference signals can sap vital power from the amplifier or even harm speakers if not attenuated.

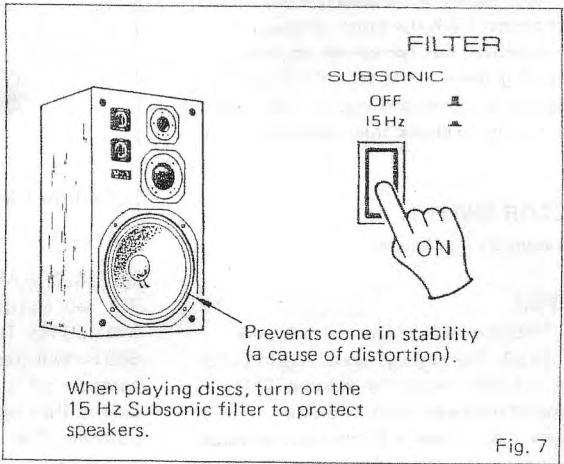

### • HIGH FILTER

Pressing this switch activates the high filter to remove high-frequency noise above 10 kHz such as record surface noise or tape hiss. There is almost no effect on the desired signal, but it is better to keep the switch off when not in use.

## 14 MODE SWITCH

Allows switching between stereo and mono operation. Normally the switch should be set for stereo.

## 15 REC OUT SELECTOR

Used for recording, this switch sends the signal from the selected source to the Rec Out jacks (regardless of the position of the Input Selector switch). Set the Input Selector to the same source if you wish to monitor the source as you record, or to any other source to listen to that source while recording. If your tape deck has three-head monitoring capability, you can monitor the signal just recorded on the tape by setting the Input Selector switch to Tape.

### • Independent Recording and Listening Examples

Rec Out selector	Input selector	Action
Tuner	Phono	Listening to a record with the speakers while recording an AM or FM broadcast.
Tuner	Tuner	Listen to an FM broadcast with the speakers while recording it.
Phono	Phono	Listen to a record with the speakers while recording it.
Phono	Tuner	Listen to an FM or AM broadcast with the speakers while recording a record.

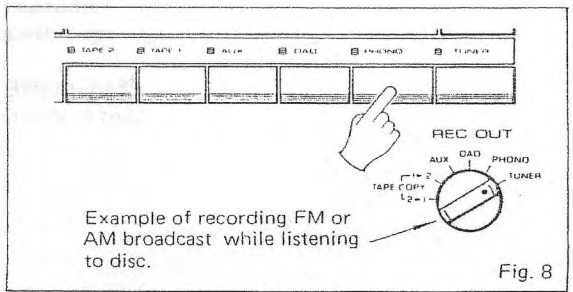



## • Tape Dubbing

Dubbing from the deck connected to the rear panel Tape 1 connectors to the deck connected to the Tape 2 connectors.

1. Set the Rec Out selector to the Tape Copy 1 ► 2 position.
  2. Set deck 1 to Play and deck 2 to Record.
- To dub from deck 2 to deck 1, set the Rec Out selector to the Tape Copy 2 ► 1 position, set deck 2 to Play and 1 to Record.

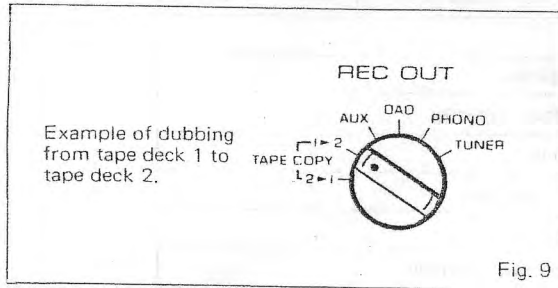

## 16 PHONO SELECTOR

Select the appropriate Phono 1 or Phono 2 position, and the appropriate MC or MM cartridge position according to the turntable and cartridge connected to each of the rear panel Phono 1 and 2 input terminals. When selecting Phono 1 also select the proper cartridge load impedance.

1. There are two Phono 1/MC position on the Phono selector for different cartridge load impedances. When using a low output moving coil cartridge, select the load impedance nearest that of the rated impedance of your cartridge. With high output MC cartridges, select the 1/MM "100 ohm" position.

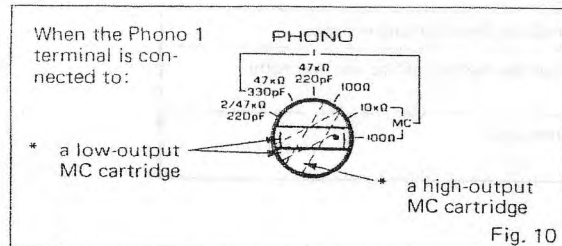

2. There are two Phono 1/MM positions for different cartridge load impedances—47 k-ohms (220/330pF) rated impedance of the cartridge you are using. Switching between the two positions with the same cartridge will vary frequency response, so you can set the Phono selector to the position that gives a desired effect.

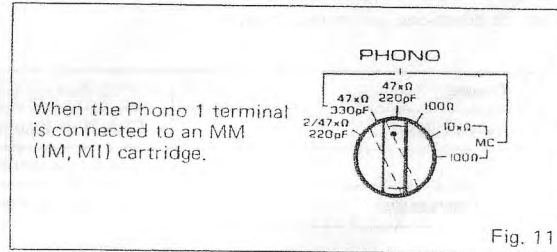

- \* Switching the Phono selector to the MC position when an MM cartridge is connected to the Phono 1 input terminals will cause a sudden variation in output volume and will have a harmful effect on your speakers.
  - \* Output voltage may vary with different cartridges according to the manufacturer, so please read the cartridge owner's manual carefully.
3. The Phono 2 input terminals are for exclusive use with MM cartridges, and the load impedance is fixed at 47 k-ohms/220 pF. Use only the 2/MM phono selector position with the Phono 2 input terminals.

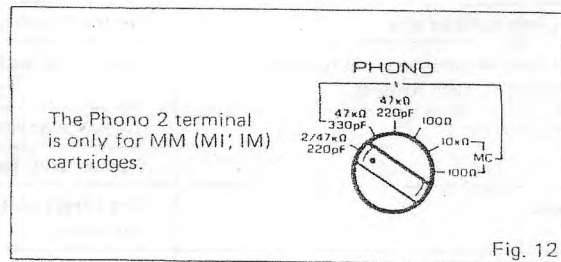

## 17 HINGED PANEL

Because the switches and controls which are not frequently operated are centralized, closing the hinged panel allows for an uncluttered panel face. To open, push the panel section lightly.

# A-1000

## TROUBLESHOOTING

Before assuming that your amplifier is faulty, check the following troubleshooting list which details the corrective action you can take yourself without having to call a service engineer. If you have any doubts or questions, get in touch with your nearest Yamaha dealer.

Fault	Cause	Cure
Power is not supplied even though the Power switch is turned on.	The power plug is not securely plugged in.	Plug it in securely.
	A fuse is blown.	Consult a service engineer.
There is no sound with any Input selector button pressed.	The Speakers switch is not set correctly.	Set the Speakers switch correctly.
	The input cords are not connected securely.	Connect them securely.
	The speaker system is not connected correctly.	Check and secure connections.
There is no sound from one speaker.	The speaker connections are not secure.	Secure the connections.
	The Balance control is set all the way to the left or right.	Adjust the Balance control correctly.
There is a lack of bass and no ambience.	The + and - cords have been reversed at the amp or the speakers.	Connect the speaker wires in the correct phase (+ and -).
There is a humming sound when playing records.	The input cords are not connected securely.	Plug the input cords in securely.
	The turntable's ground wire is not connected.	Connect the ground wire.
Sound from MC cartridge is low.	The output of the MC cartridge is connected to the Phono 2 terminal.	Connect it to the Phono 1 terminal.
	The Phono Selector switch is set to MM.	Set the Phono Selector switch to MC.
There is a howling sound when playing records at high volume.	The turntable and the speakers are too close together or the turntable is not mounted on a firm surface.	Change the location of the turntable or the speakers.
Interference from private commercial broadcasting.	A transmitter is located nearby.	Consult a service engineer.
		Consult with the company that is transmitting.
Turning the Bass or Treble knob does not affect the tone.	The Direct switch is on.	The Direct switch must be turned off to use the tone controls.
Volume is too low even when the Volume control is turned up.	The Muting switch is on.	Turn the Muting switch off.



# A-1000

## SPECIFICATIONS

### Continuous Power Per Channel

20 Hz ~ 20 kHz (0.005% THD 8Ω)	120W
	(Class A 10W)
(0.007% THD 6Ω)	140W
1 kHz (0.005% THD 8Ω)	130W
(0.005% THD 6Ω)	150W

### Power Band Width

0.03% THD 60W (8Ω)	10 Hz ~ 100 kHz
--------------------	-----------------

### Damping Factor

1 kHz 8Ω	90
----------	----

### Input Sensitivity/Impedance

Phono 1 MC	160 μ (V/10 kΩ, 100Ω)
MM	2.5 mV/47 kΩ 220 pF
	47 kΩ 330 pF
	100 Ω

Phono 2 MM	150 mV/47 kΩ
------------	--------------

### Input Sensitivity (New IHF)

Phono MC	15 μV
MM	0.23 mV
Aux, Tape, Tuner	14 mV

### Maximum Input Signal

1 kHz, 0.01% THD Phono MC	10 mV
MM	165 mV

### Output Level/Impedance

Rec Out	150 mV/470 Ω
---------	--------------

### Headphone Jack Rated Output/Impedance

0.005% THD	0.89 V/8 Ω
------------	------------

### Frequency Response

20 Hz ~ 20 kHz Aux, Tape, Tuner	+0
(Direct ON)	-0.5 dB

### RIAA Equalization Deviation

Phono MC	±0.3 dB
MM	±0.2 dB

### Total Harmonic Distortion

Phono MC to Rec Out (3V)	0.005%
Phono MM to Rec Out (3V)	0.003%
Aux, Tape, Tuner to SP Out 60W/8Ω	0.005%

### Intermodulation Distortion

Aux, Tape, Tuner Rated Output/8Ω	0.002%
1W/8Ω	0.003%

### Signal to Noise Ratio (IHF-A-Net work)

Phono MC (500μV Input Shorted)	80 dB
Phono MM (5 mV Input Shorted)	94 dB
Aux, Tape, Tuner (Shorted)	106 dB

### Signal to Noise Ratio (New IHF)

Phono MC	76 dB
MM	79 dB
Aux, Tape, Tuner	86 dB

### Residual Noise (IHF-A-Network)

	125 μV
--	--------

### Channel Separation

Phono MM (Input Shorted 1kHz, vol - 30dB)	70 dB
Aux, Tape (5.1 kΩ, 1 kHz, vol - 30dB)	65 dB

### Tone Control Characteristics

Bass boost/cut	±10 dB (at 20Hz)
turnover frequency	125, 500 Hz
Treble boost/cut	±10 dB (at 20 kHz)
turnover frequency	2.5k, 8kHz

### Filter Characteristics

Low (Subsonic)	15 Hz, -12 dB/oct
High	10 kHz, -12 dB/oct

### Continuous Loudness Control (Level-related equalization)

Attenuation	-20 dB (at 1kHz)
-------------	------------------

### Audio Muting

	-20 dB
--	--------

### Gain tracking error (0 to -60 dB)

	2 dB
--	------

### Power Supply

	AC120V, 60Hz
--	--------------

### Power Consumption

	280W
--	------

### AC Outlet

Switched x 2	200W max total
Unswitched x 1	200W max

Dimensions (W x H x D) . . . . . 435 x 146 x 424.5 mm  
(17-1/8" x 5-3/4" x 16-3/4")

Weight . . . . . 13 kg  
(28.7 lbs.)

\* Specifications subject to change without notice.

SINCE 1887



**YAMAHA**

NIPPON GAKKI CO., LTD. HAMAMATSU, JAPAN