

PIONEER

SA-9900

Top-of-the-line stereo integrated amplifier with state-of-the-art technology and advanced features.



Utilizing the unique chassis construction that permits easy wire connection and adds to high performance by eliminating shielded cables for phono circuit, the SA-9900 has no peer for advanced feature design. RIAA equalization is precise within $\pm 0.2\text{dB}$. And with unique twin tone control system up to 5,929 different kinds of tonal characteristics may be obtained. The parallel push-pull direct-coupled three-stage Darlington OCL circuit with two-stage differential amplifiers is employed in the power amplifier section that delivers continuous power output of 110 watts per channel, min. RMS at 8 ohms or 4 ohms from 20 Hertz to 20,000 Hertz with no more than 0.1% total harmonic distortion. There are special level control and impedance selector provided for the PHONO 2 terminals. Tone characteristics

may be cancelled with a "tone defeat" switch. The volume control is the 22 contact points attenuator type for precision, with its 2dB steps illuminated by an edge light. Low filters are the 15Hz and 30Hz type; the high filter is a 2-step type with 8KHz and 12KHz turnover frequency to permit tape hiss elimination and rumble cut. Another prominent feature is a tape duplication switch permitting tape-to-tape duplication while you listen to another source. Two pairs of high fidelity speaker systems may be used, driven either independently or simultaneously. And to prevent DC shock in the OCL circuit, Pioneer has employed an automatic protection circuit, complete with temperature compensation circuit and more.

Languages: English, Deutsch, Français

SA-9900



CLASS-A OPERATION EQUALIZER WITH 3-STAGE DIRECT-COUPLED SEPP DESIGN USING DUAL POWER SUPPLY AND FIRST-STAGE FET-EQUIPPED DIFFERENTIAL AMPLIFIER

The highly sophisticated equalizer of the SA-9900 employs low-noise FET (Field Effect Transistor) in its first-stage differential amplifier to specifically eliminate that area of odd-numbered harmonic distortion which is most irritating to the human ear. This, and the equalizer's low-noise performance, enhances sound transparency at low-volume listening levels. In the second-stage voltage amplification section, a constant current load is used to obtain linear response and low distortion. It contributes to the excellent phase characteristics in the low sound range and to transient response overall. The SEPP type output stage is distinguished by its highly efficient use of supply voltage. By applying a large amount of drive current, the equalizer performs in Class-A operation clear down to the low load drive (around 5k ohms) point. Further, by applying an extra-high $\pm 48V$ DC (total 96V) supply to this stage, the PHONO overload level is extended to 500mV (1kHz RMS, THD 0.1%), providing the super-wide dynamic range necessary for true high fidelity record reproduction.

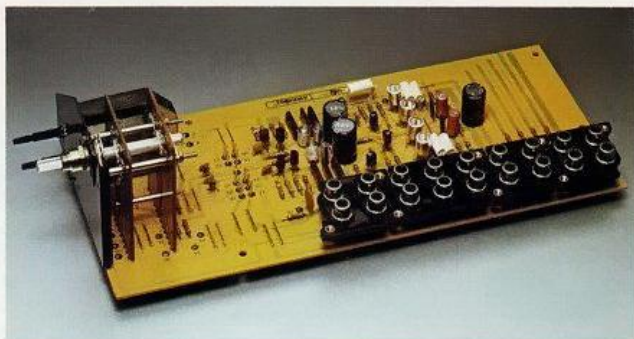

PRECISE RIAA EQUALIZATION WITHIN $\pm 0.2dB$

In order to minimize deviation from the RIAA standard equalization curve, Pioneer employs precision circuit elements such as micro-tolerance metal film resistors and styrol capacitors in this equalizer. As a result, RIAA equalization is within $\pm 0.2dB$ for greatly enhanced high-fidelity performance. All the information found in the record groove and passed on to the equalizer is handled with precision.

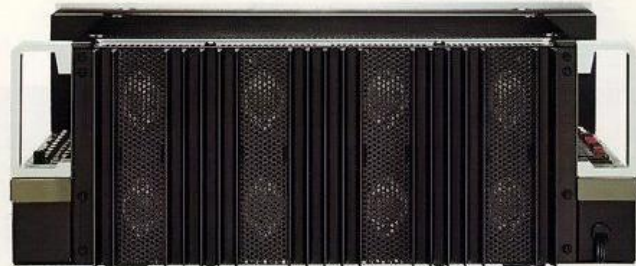

PHONO-2 INPUTS FEATURE LEVEL ADJUSTMENT AND INPUT IMPEDANCE SELECTOR

A special level control is provided for the PHONO-2 source input circuit. With it you can control input sensitivity from 2.5mV to 10mV (0dB to $-12dB$). In the 0dB to $-6dB$ range, level is adjusted through a NFB (negative feedback) circuit, while in the $-6dB$ to $-12dB$ range it is controlled by the output attenuator. This means that in the NFB circuit range, PHONO overload level is doubled to 1V (1kHz RMS). Discs cut at relatively high levels, and cartridges with high output voltages, can be used without clipping or distortion. The level control has many uses, among which is to allow comparison of different kinds of phono cartridges for in-system performance suitability. Additionally, there is a 4-position input impedance selector for the PHONO-2 input circuit, allowing you to select the proper impedance (35k ohms, 50k ohms, 70k ohms or 100k ohms) to best match your cartridge.

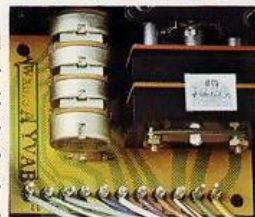

3-STAGE DIRECT-COUPLED TONE CONTROL AMPLIFIER WITH DUAL POWER SUPPLY SYSTEM AND FET-EQUIPPED DIFFERENTIAL AMPLIFIER

Pioneer's revolutionary amplifier design concept is also applied to the tone control amplifier section. It features a dual $\pm 48V$ power supply system (total 96V) and an FET-equipped first-stage differential amplifier with the main emphasis on linearity, low distortion and transient response. In the differential amplifier section, the dual power supply applies 100% DC negative feedback so that DC stability is extraordinarily high, ensuring that when switches are altered you hear no click noises.

PIONEER'S UNIQUE TWIN TONE CONTROL SYSTEM

You have approximately 5,929 different tonal combinations at your command by employing the MAIN and SUB controls on the BASS and TREBLE tone controls. SUB control allows you to boost or cut the frequency in both low and high frequency ranges without exerting influence on the midrange sound. The SUB controls may be used independently or combined in function with the MAIN controls. Both MAIN controls have 11 steps of 1.5dB each, covering a range of $-7.5dB$ to $+7.5dB$ (BASS optimum: 100Hz; TREBLE optimum 10,000Hz). The

SUB control for TREBLE has a range of -4.5dB to $+4.5\text{dB}$ at 20,000Hz in steps of 1.5dB each, while the SUB control for BASS ranges from -4.5dB to $+4.5\text{dB}$ at 50Hz, also in 1.5dB steps. Excellent transient response and phase linearity are assured by the CR-type SUB and NFB-type MAIN control circuits. With a little practice, you can use these sophisticated twin tone controls to obtain the precise acoustical characteristics you require in your listening room regardless of the program source, type of phono cartridge, quality of speakers or etc. you employ.

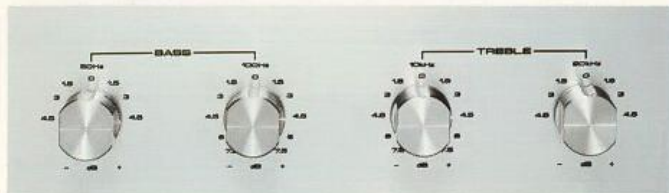

TONE ON/OFF SWITCH

When set to its OFF position, this switch instantly cancels all tone control effects. This provides an easy and unfailing way to compare the tonal adjustment characteristics you have selected to the "flat" or uncolored output of the amplifier without the need to return the tone controls to their center positions.

MAIN VOLUME ATTENUATOR AND 3-POSITION AUDIO MUTING SWITCH

The main volume control on the SA-9900 is a professional attenuator type with 22 separate contact points. Microtolerance printed resistors are used to provide a "light touch" yet assure precision volume adjustment. For your convenience, the control is illuminated from an angle by a softly-glowing lamp, and features dB markings on the panel. A separate audio muting switch is provided — a lever type muting attenuator with three positions for instantaneous volume attenuation of 0dB, -15dB and -30dB .

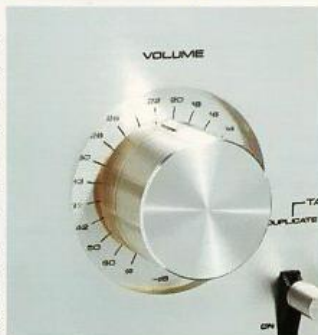

VERSATILE LOW AND HIGH FILTERS

The high and low filters both feature independent 2-position switching with 12dB/oct. sharp cut-off characteristics. Roll-off points for the low filter are set at 15Hz and 30Hz to allow precise elimination of turntable rumble and other noises in the low range. The high filter has 8kHz and 12kHz roll-off points to cancel tape hiss and/or other high-frequency noises.

HIGH-QUALITY POWER PLANT WITH 3-STAGE DARLINGTON PARALLEL PUSH-PULL DIRECT-COUPLED OCL POWER AMPLIFIER

A vital requirement for any high fidelity power amplifier is that it is able to produce a large amount of low-distortion power over its entire range. In the SA-9900, this need is met with an advanced 3-stage Darlington parallel push-pull direct-coupled OCL circuit. And it really delivers: **continuous power output of 110 watts* per channel, min. RMS at**

8 ohms or 4 ohms from 20 Hertz to 20,000 Hertz, with no more than 0.1% total harmonic distortion. Needless to say, it easily covers even the most demanding of uses (reproducing sources having extra-wide dynamic range, for instance) with extra margin. Power stability has not been sacrificed either, since the use of a 2-stage differential amplifier and bias compensation circuit eliminates DC voltage at the speaker output terminals.



OPTIMUM NEGATIVE FEEDBACK FOR HIGH QUALITY POWER

In the 2-stage differential amplifier section, a constant current circuit widens the operation range of transistors and allows the application of partial current feedback. As a result, open-loop characteristics are improved and optimum negative feedback from the output stage to the first stage is applied, eliminating instability and possible deterioration of transient response or load resistance. High fidelity source reproduction takes on exceptional clarity, distinctiveness and rich musicality. The important NFB loop decides the low-frequency response characteristics in any amp, and in the SA-9900, this circuit has a large "time constant" to further improve phase linearity.

CROSSOVER DISTORTION ELIMINATED BY NEW CIRCUIT

- (1) By floating the emitter resistor of the driver stage from the zero potential point (output terminals), the power amp stage can be operated as Class-A into the range of strongest amplitude to eliminate crossover distortion.
- (2) A constant current load is used in the pre-driver stage (second-stage differential amp section), thus changes in current caused by fluctuations in external power supply voltage are minimized. Further, a newly-developed bias supply system is used to compensate for temperature differences between each transistor. Thermal drift, temperature increases in the power transistors, and other potentially damaging power-related abnormalities are prevented.

AUTOMATIC PROTECTION CIRCUIT AND THERMAL DETECTION POWER LIMITER CIRCUIT

Large heat sinks, located well to the rear of the chassis to positions where they can radiate unwanted heat most effectively, provide stable thermal compensation. An automatic electronic protection circuit, equipped with power relay, and a current regulation circuit take adequate care of abnormal current overloads, speaker terminal/lead short-circuits and other power-related troubles. Additionally, a newly-developed thermal detection circuit (Pioneer Patent pending) is employed to limit power output and suppress internal temperature increases to protect power transistors. This system regulates current overflow to prescribed levels at low load power output so that continuous power output remains the same at 4-ohm and 8-ohm impedance levels. In the current limiting

circuit, no non-linear elements such as diodes, etc., are ever used. This means instantaneous off/on speaker operation and higher performance stability – just another advantage of this fine Pioneer amplifier.

ADVANCED CHASSIS CONSTRUCTION FOR EASY CORD CONNECTION AND HIGHER PERFORMANCE RELIABILITY

The SA-9900 has a unique chassis: input terminals are arranged on the right side, with output terminals on the left, simplifying cable and cord connection for versatile use. Input

and output terminals are completely separated so that signal interference is eliminated for improved performance. Additionally, the input selection switch is fixed to the printed circuit board for equalizer amplifier terminals; this does away with shielded wire connections (the switch is controlled from the front panel by means of a control knob) so that "stray capacitance" high-frequency loss is completely eliminated. Adopting this advanced chassis allows us to arrange the heat sinks at the side of the back panel where wide heat radiation and effective temperature compensation can be maximized.



BLOCK DIAGRAM

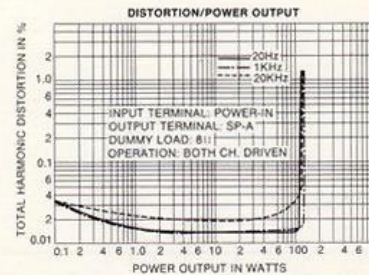
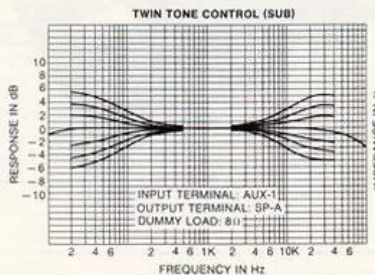
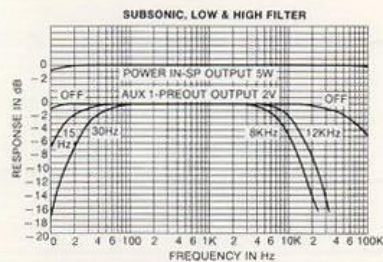
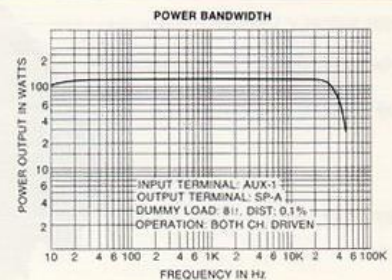
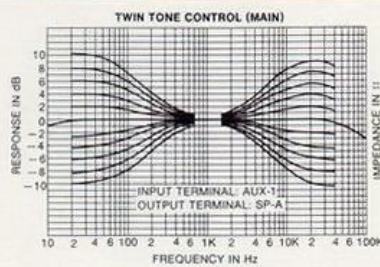
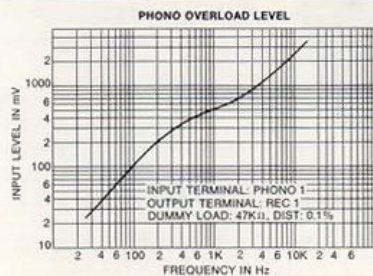
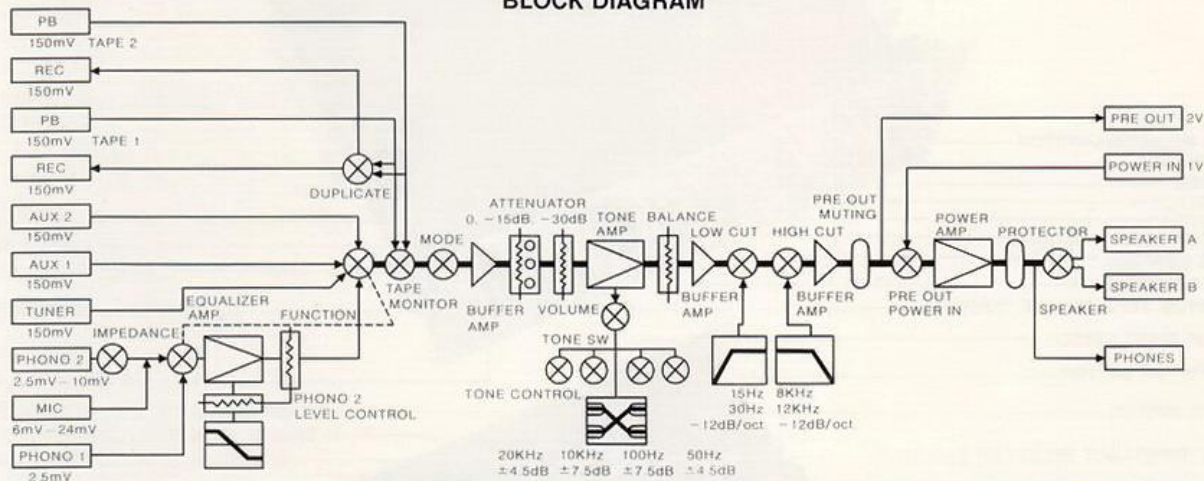

TREBLE MAIN TONE CONTROL
 HEADPHONE JACK
 HIGH FILTER
 BASS MAIN TONE CONTROL
 TONE DEFEAT SWITCH
 BASS SUB TONE CONTROL

SPEAKER SELECTOR SWITCH
 POWER SWITCH
 LOW FILTER
 MODE SWITCH
 ATTENUATOR
 TREBLE SUB TONE CONTROL
 BALANCE CONTROL
 VOLUME CONTROL
 ATTENUATOR TYPE VOLUME CONTROL

TAPE DUPLICATE SWITCH
 TAPE MONITOR SWITCH
 FUNCTION SWITCH
 PHONO 2 IMPEDANCE SELECTOR SWITCH
 PHONO 2 LEVEL CONTROL

POWER SUPPLY UNIT
 22000 μ F ELECTROLYTIC CAPACITORS
 LARGE POWER TRANSFORMER
 POWER AMP. UNIT

INPUT TERMINALS
 GROUND TERMINALS

POWER INDICATOR LAMP
 TAPE DUPLICATE SWITCH
 TAPE MONITOR SWITCH
 FUNCTION SELECTOR SWITCH

MICROPHONE JACK
 TREBLE SUB TONE CONTROL SWITCH
 TREBLE MAIN TONE CONTROL SWITCH
 BASS MAIN TONE CONTROL SWITCH

BASS SUB TONE CONTROL SWITCH
 CONTROL AMP. UNIT

PRE/POWER AMP. SEPARATOR SWITCH
 PRE-AMP. OUT TERMINAL
 POWER AMP. IN TERMINAL
 PROTECTION CIRCUIT
 SPEAKER TERMINAL (A, B)

AC OUTLETS

LARGE HEAT SINK

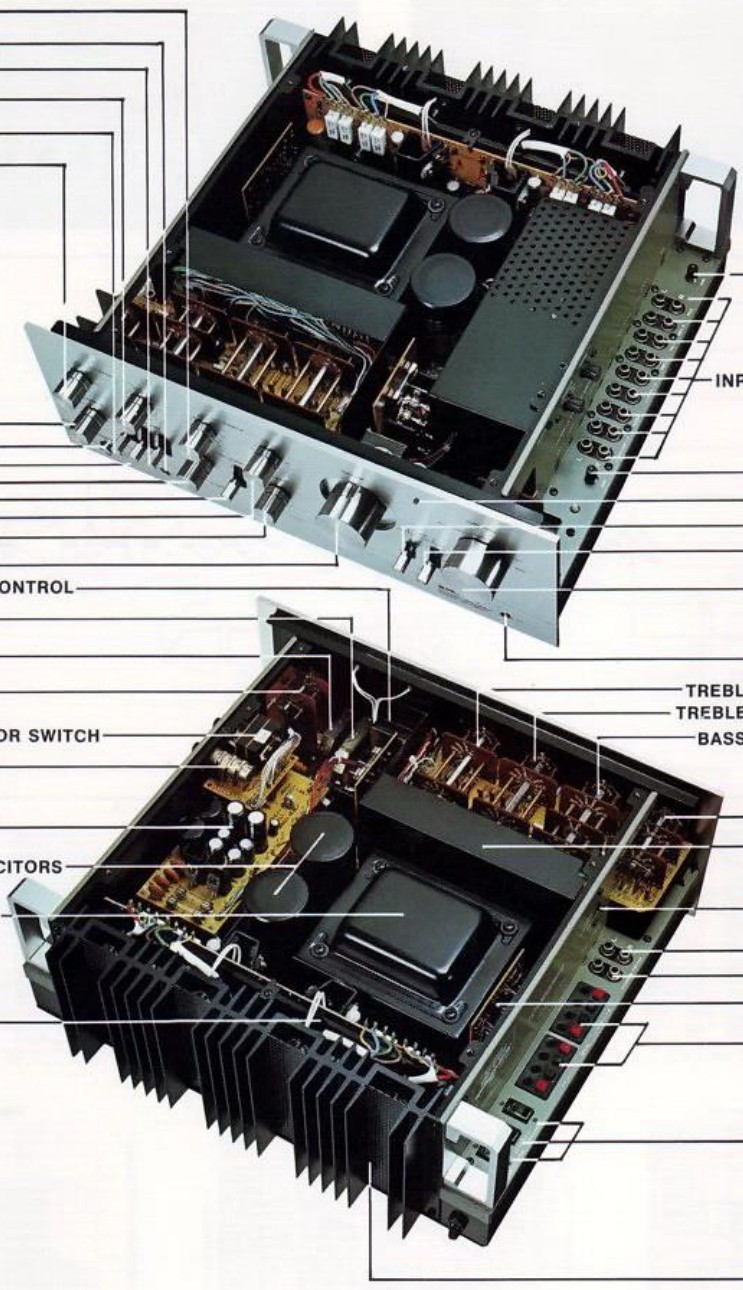

SA-9900 SPECIFICATIONS
POWER AMPLIFIER SECTION

Circuitry: 2-stage differential amplifiers,
 3-stage Darlington parallel push
 pull, direct-coupled, OCL

**Continuous Power Output of 110 watts* per channel,
 min. RMS at 8 ohms or 4 ohms from 20Hertz to 20,000
 Hertz with no more than 0.1% total harmonic distortion.**

Continuous Power Output:
 1.000 Hertz: 120 watts per channel (8 ohms)
 (Both channels driven) 120 watts per channel (4 ohms)
 Total Harmonic Distortion: No more than 0.1%
 (20Hertz to 20,000Hertz) (continuous rated power output)
 No more than 0.04%
 (55 watts per channel power output,
 8 ohms)
 No more than 0.04%
 (1 watt per channel power output,
 8 ohms)
 Intermodulation Distortion: No more than 0.1%
 (continuous rated power output)
 No more than 0.04%
 (55 watts per channel power output,
 8 ohms)
 No more than 0.04%
 (1 watt per channel power output,
 8 ohms)
 Frequency Response: 10Hertz to 80,000Hertz +0dB, -1dB
 Input Sensitivity/Impedance: 1V/50 K ohms (POWER AMP. IN)
 Output Speaker: A, B, A+B
 Headphone: Low Impedance
 Damping Factor: 30 (20Hertz to 20,000Hertz, 8 ohms)
 Hum and Noise: 110dB (IHF, short-circuited A network)

PREAMPLIFIER SECTION

Circuitry
 Equalizer Amplifier: 1st. stage FET equipped differential
 amplifier, 3-stage direct coupled
 class A SEPP type
 Control Amplifier: 1st. stage FET equipped differential
 amplifier, 3-stage direct coupled type
 Input Sensitivity/Impedance
 PHONO 1: 2.5mV/50 Kohms
 PHONO 2: 2.5mV to 10mV/35, 50, 70, 100 Kohms

MIC: 6 to 24mV/85 Kohms
 TUNER: 150mV/50 Kohms
 AUX 1: 150mV/50 Kohms
 AUX 2: 150mV/50 Kohms
 TAPE PLAY 1: 150mV/50 Kohms
 TAPE PLAY 2: 150mV/50 Kohms
 Phono Overload Level (T.H.D. 0.1%)
 PHONO 1: 500mV (1KHz)
 PHONO 2: 500mV to 1.0V (1KHz)
 Output Level/Impedance
 TAPE REC 1, 2: 150mV
 PRE OUT: 2V/1 Kohms
 Harmonic Distortion: No more than 0.05% (20Hz to 20KHz)
 Frequency Response:
 PHONO (RIAA equalization): 30Hz to 15KHz \pm 0.2dB
 TUNER, AUX, TAPE PLAY: 7Hz to 40KHz +0dB, -1dB
 Tone Control (1.5dB Step)
 BASS: \pm 7.5dB (100Hz) main control
 \pm 4.5dB (50Hz) sub control
 \pm 7.5dB (10KHz) main control
 \pm 4.5dB (20KHz) sub control
 TREBLE:
 Filter
 LOW: 15Hz, 30Hz (12dB/oct.)
 HIGH: 8KHz, 12KHz (12dB/oct.)
 Hum and Noise (IHF, short-circuited A network)
 PHONO: 70dB
 MIC: 65dB
 TUNER, AUX, TAPE PLAY: 95dB
 Attenuator: 0, -15dB, -30dB
SEMICONDUCTORS
 FETs: 10
 Transistors: 74
 Diodes: 33
MISCELLANEOUS
 Power Requirements: 120V 60Hz only or 220V 50-60Hz only
 or 120, 220, 240V (switchable) 50-60Hz
 500 watts (max.)
 Power Consumption:
 Dimensions: Without package:
 16-17/32(W) x 6-1/2(H) x 15-7/8(D) inch
 420(W) x 165(H) x 403(D) mm
 Weight: Without package: 44 lb. 1 oz./20.0kg

NOTE: Specifications and design subject to possible modification without notice.



PIONEER ELECTRONIC CORPORATION / 4-1, Meguro 1-chome, Meguro-ku, Tokyo 153, Japan
 U.S. PIONEER ELECTRONICS CORPORATION / 75 Oxford Drive, Moonachie, New Jersey 07074, U.S.A.
 PIONEER ELECTRONIC (EUROPE) N.V. / Luthagensteenweg No. 9, 2030 Antwerp, Belgium
 PIONEER ELECTRONICS AUSTRALIA PTY. LTD. / 17B-184 Boundary Road, Braeside, Victoria 3195, Australia