

Quartz PLL DIRECT DRIVE
STEREO TURNTABLE

PL-610

OPERATING INSTRUCTIONS

KUT
KCT

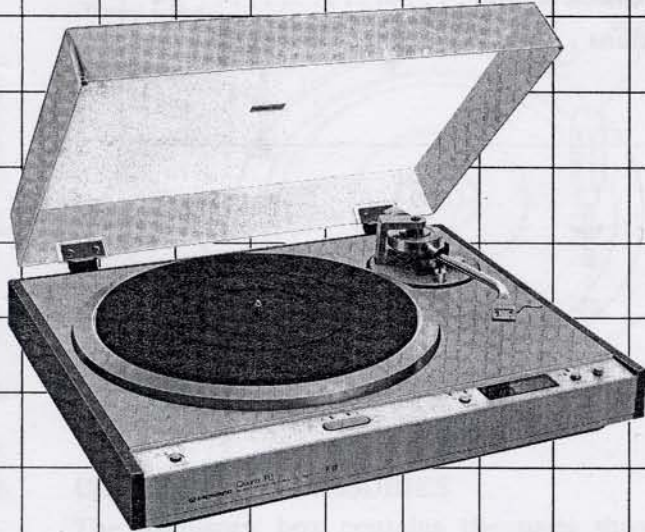

IMPORTANT NOTICE

The serial number for this equipment is located on the rear. Please write this serial number on your enclosed warranty card and keep it in a secure area. This is for your security.

**WARNING: TO PREVENT FIRE OR SHOCK HAZARD,
DO NOT EXPOSE THIS APPLIANCE TO RAIN OR
MOISTURE.**

 **PIONEER**[®]

CONTENTS

Features	2	Playing Procedure	10
Before Use	3	Operation Principle of Quartz PLL DD Motor	12
Assembly Procedure	4	Maintenance	13
Installation Precautions	5	Trouble? Check it out	14
Connections to Stereo Amplifier	5	Specifications	15
Adjusting the Tonearm	6		
Panel Facilities	8		

FEATURES

Quartz PLL Brushless DC Hall Motor

The model adopts a quartz PLL system which compares the waveforms of the high-precision reference oscillator employing a quartz crystal with the output waveforms of the frequency generator built into the rotor of the motor, and thereby controls the rotational speed of the motor. This system features superb time and temperature drift as well as load resistance characteristics, so the motor guarantees speed accuracy at all times.

Precision-engineered Parts for an Excellent Speed Performance

The precision-finished center shaft and bearings (with a circularity of less than 0.2μ) and the platter with its high inertial mass of $340\text{kg}\cdot\text{cm}^2$ prove to be a winning combination in this model. Together with the quartz PLL brushless Hall motor, they yield such top-notch characteristics as a wow and flutter of less than 0.025% (WRMS) and a signal-to-noise ratio of better than 75dB (DIN-B). This is a truly professional performance.

Electronic Auto Return Mechanism

An optical non-contact detection method is used to detect the position of the auto return, and no harmful lateral pressure is exerted on the tonearm while this is being detected. A special DC motor is used for the return of the tonearm and for the arm elevation operations. This means that a smooth and reliable quick return operation is ensured without affecting the rotation of the platter.

Handy Quick Play Function

When a record is about to be played, the quick play function swings into action and starts the platter rotating just by the movement of the tonearm as it moves away from the arm rest to the record. An optical system is employed for detection and absolutely no excess force is exerted on the tonearm.

All-electronic Durable Quick Stop Function

The model incorporates an all-electronic brake to bring the platter to a halt instantly. When the tonearm swings back to the arm rest, a current flowing in the opposite direction to that determining the platter's rotation passes to the motor drive coil and, in an instant, the platter is stopped rotating. This function is convenient for changing over records speedily.

No-howl, Vibration-resistant Coaxial Suspension System

The platter and the tonearm are secured to the base board, and the base board is spring-mounted and separated from the cabinet with what Pioneer calls the coaxial suspension construction. This cuts out virtually all of the vibrations transmitted from the floor, and greatly reduces the chances of howl.

BEFORE USE

REMOVE THE TRANSIT SCREWS

As shown in the figure, use a Phillips screwdriver to remove the three screws used when transporting the turntable.

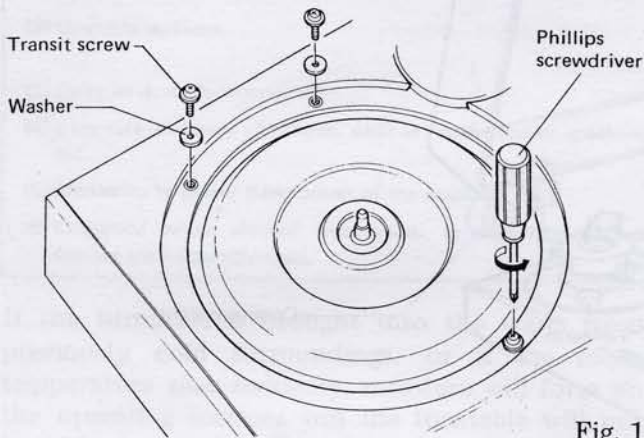

Fig. 1

CHECK THE ACCESSORIES

The accessory box contains the parts shown in the Fig. 2. Check that they are all inside. The EP adaptor is used for records with a large center hole, and the screwdriver is required for adjustments and when mounting the cartridge. Store these parts safely.

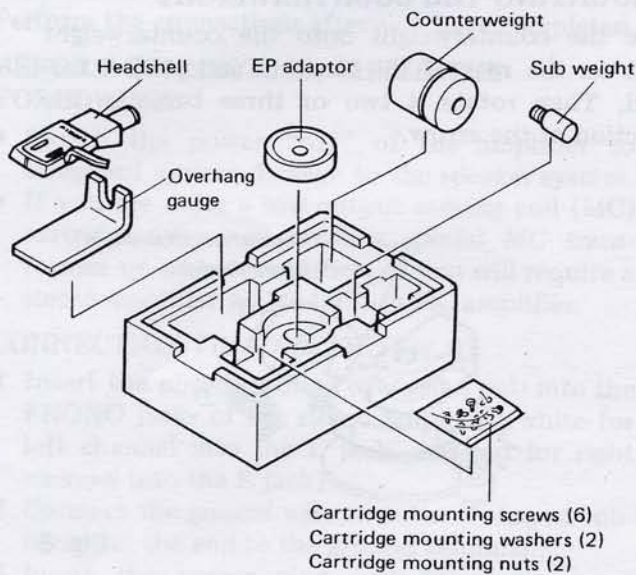

Fig. 2

ATTACH THE CARTRIDGE

Follow the procedure below for attaching the cartridge to the accessory headshell.

1. Connect the headshell leads to the cartridge. Refer to Fig. 3 for the polarity of these leads and connect plus to plus and minus to minus.

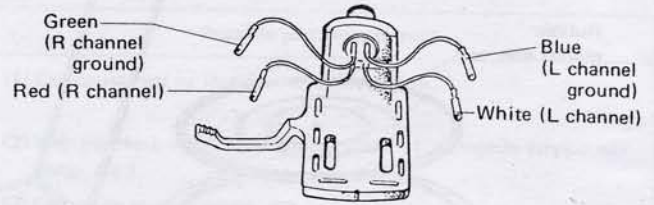

Fig. 3

2. Secure the cartridge to the headshell temporarily using the accessory cartridge mounting screws, washers and nuts, as shown in Fig. 4.

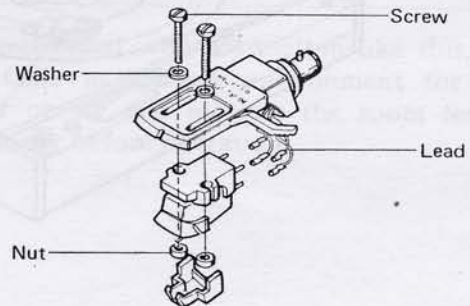

Fig. 4

3. Refer to Fig. 5 and use the accessory overhang gauge to adjust the overhang so that cartridge stylus tip is positioned over the indicator line of the gauge, and then tighten the cartridge mounting screws. Make sure that the cartridge does not tilt to one side (Fig. 6). If there is any tilting, you will not be able to obtain a normal stereo effect.

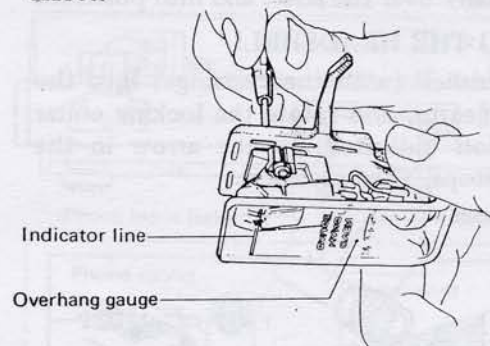

Fig. 5

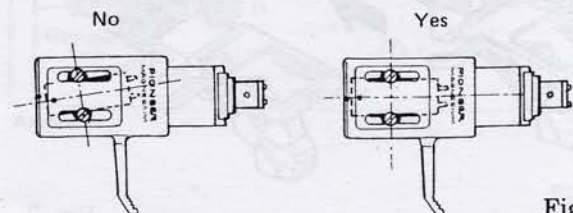
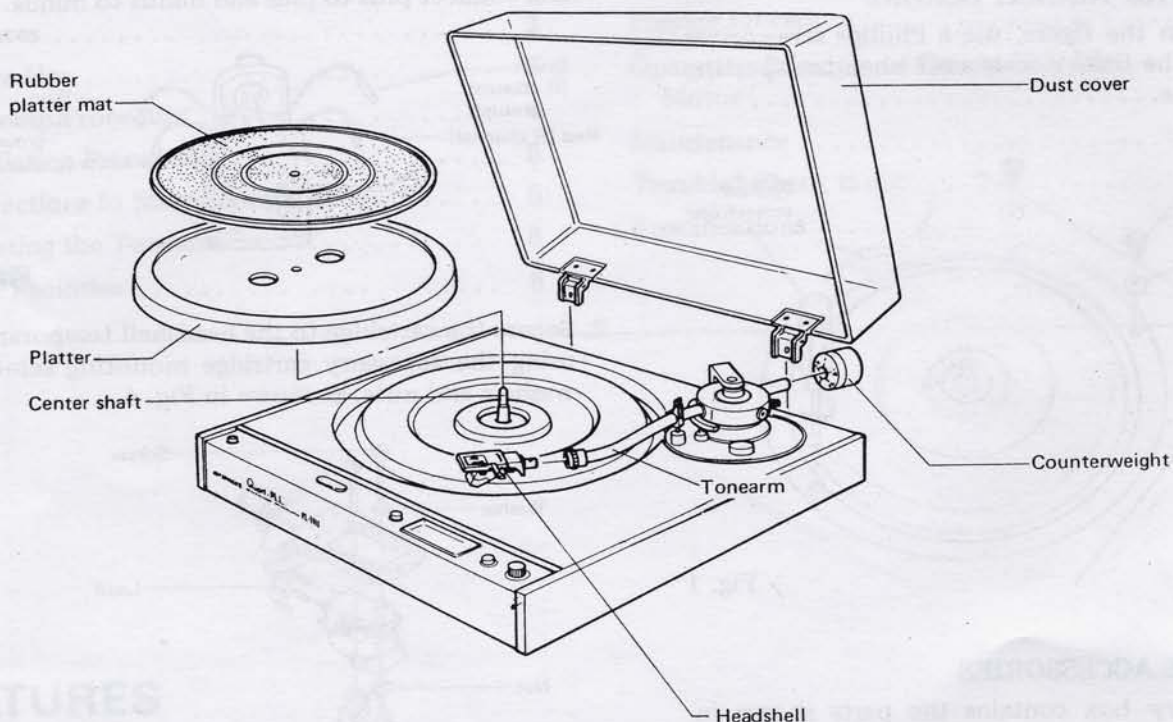

Fig. 6

ASSEMBLY PROCEDURE



1. MOUNTING THE PLATTER AND RUBBER PLATTER MAT

Refer to the assembly figure, and place both the platter and the rubber mat down over the center shaft. The platter is heavy, so use both hands to lift it horizontally over the shaft and into position.

2. MOUNTING THE HEADSHELL

Insert the headshell (with the cartridge) into the end of the tonearm, and rotate the locking collar in the direction indicated by the arrow in the figure until it stops. Then secure it.

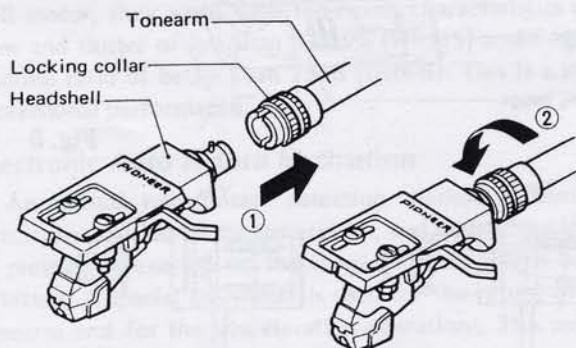

Fig. 7

3. MOUNTING THE COUNTERWEIGHT

Slide the counterweight onto the counterweight shaft on the rear of the tonearm and push it forward. Then rotate it two or three turns in the direction of the arrow.

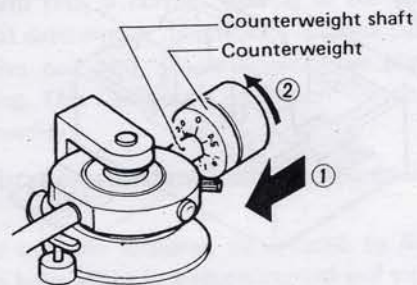

Fig. 8

INSTALLATION PRECAUTIONS

When installing this turntable, make sure that you avoid the following conditions:

Conditions to be avoided	Possible problems caused
(1) Exposure to direct sunlight, high temperatures or high humidity.	(1) Can cause rust or interfere with insulation.
(2) Unstable surfaces.	(2) Will interfere with normal operation of turntable (stylus will jump, etc.).
(3) Dirty or dusty locations.	(3) Can cause scratch noise.
(4) Exposure to heavy vibrations, such as on the top of speakers, etc.	(4) Can cause howl.
(5) Proximity to power transformer of the amplifier.	(5) Can cause hum.
(6) Locations where alcohol, insecticides, or inflammable substances are frequently used.	(6) Can corrode dust cover or outside of cabinet.

If the turntable is brought into the warm from previously cold surroundings, or if the room temperature rises suddenly, moisture will form on the operating sections and the turntable will not be able to display its performance to the full.

If confronted with a situation like this, leave the turntable in its new environment for about an hour or try and increase the room temperature gradually before operation.

CONNECTIONS TO STEREO AMPLIFIER

Perform the connections after you have completed the tonearm adjustments.

BEFORE CONNECTING, CHECK THE FOLLOWING:

- Switch the power "off" of the amplifier to safeguard against damage to the speaker system.
- If you are using a low-output moving coil (MC) cartridge, you will need a special MC transformer or a head amplifier, or you will require a stereo amplifier with a built-in MC amplifier.

CONNECTION PROCEDURE (Fig. 9)

1. Insert the phono cables (white and red) into the PHONO jacks of the stereo amplifier (white for left channel into the L jack, and red for right channel into the R jack).
2. Connect the ground wire with the Y-shaped connector at the end to the ground terminal.
3. Insert the power plug into the convenience AC outlet of the amplifier.

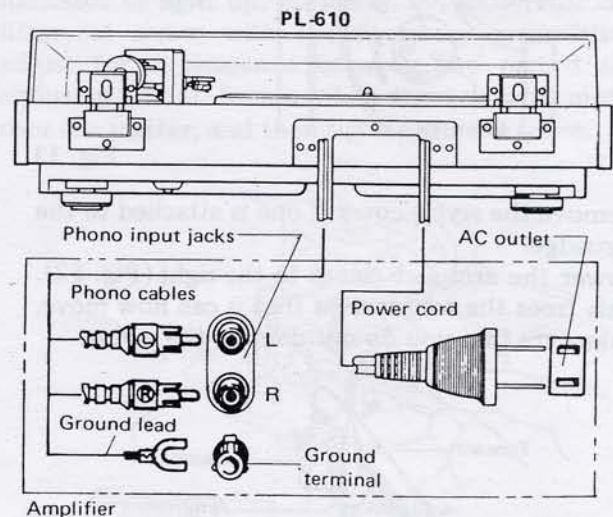

Fig. 9

ADJUSTING THE TONEARM

Adjusting the tonearm has a marked effect on the reproduced sound from records. Proceed with the adjustments after you have completed the assembly, installation and connections to the amplifier.

TRACKING FORCE ADJUSTMENT

If the correct tracking force is not applied, the reproduced sound will be distorted and the stylus may jump during play. Follow the procedure outlined below to apply the correct tracking force for the cartridge which is attached to the headshell.

Adjust the horizontal balance

1. Set the POWER switch to ON. The ARM ELEVATION switch's DOWN (▼) indicator should now light up. Check that it is on. Now press the POWER switch again and set to OFF.

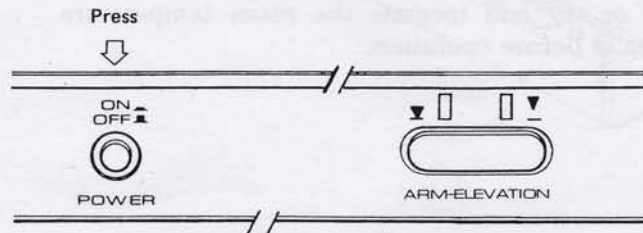

Fig. 10

2. Rotate the ANTI-SKATE knob and set the "0" to the index line (Fig. 11).

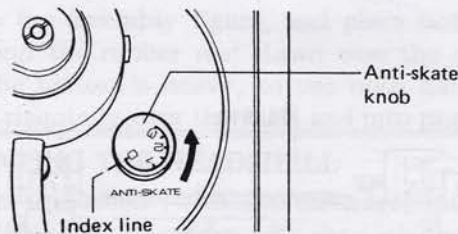

Fig. 11

3. Remove the stylus cover if one is attached to the cartridge.
4. Lower the arm rest clamp to the right (Fig. 12). This frees the tonearm so that it can now move. Take care that you do not damage the stylus.

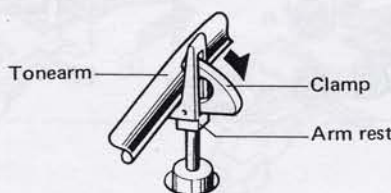

Fig. 12

5. Place your finger under the headshell's finger lift, and hold it between the arm rest and platter. Use one hand to support the tonearm and the other to rotate the counterweight so that the tonearm is perfectly horizontal, without tilting to the headshell side or counterweight side. If the cartridge is too heavy and the horizontal balance cannot be attained, attach the accessory sub-weight to the tonearm's counterweight shaft as shown in Fig. 14.

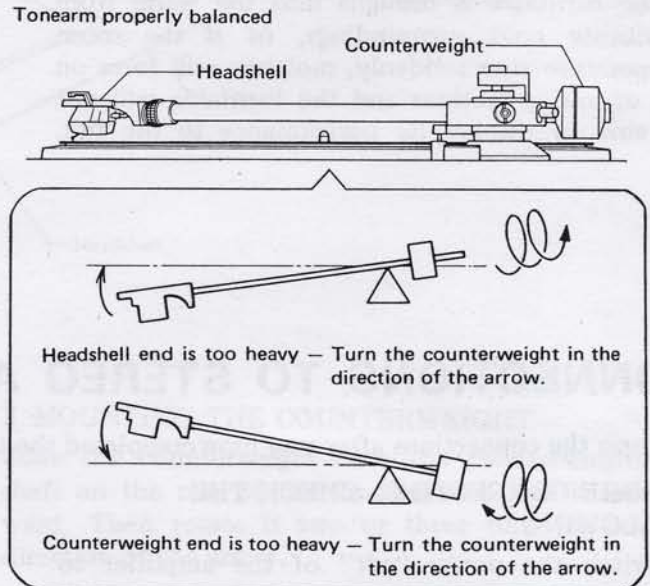

Fig. 13

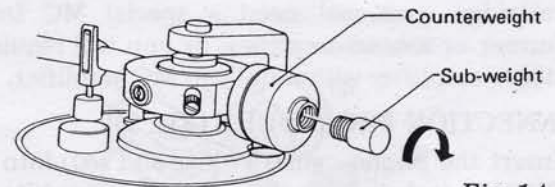

Fig. 14

6. Return the tonearm to the arm rest and secure with the clamp.

Applying the tracking force

1. Rotate the tracking-force scale ring and set the "0" to the index line of the counterweight shaft (Fig. 15). Do not rotate the counterweight since this will throw the cartridge out of horizontal balance and prevent the correct tracking force from being applied.

2. As in Fig. 16, rotate the counterweight in the direction of the arrow, and set the number on the scale ring corresponding to the correct cartridge to the index line on the counterweight shaft. The tracking-force scale ring has 0.5 gram graduations, and one full turn of the counterweight will yield a tracking force of 3 grams.

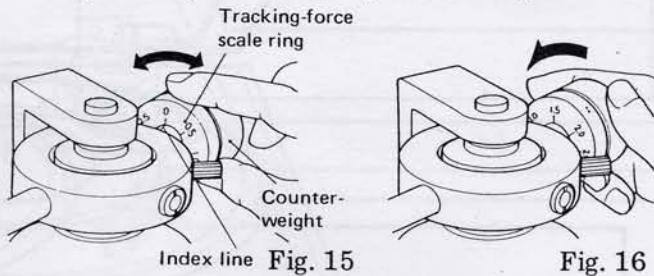

ANTI-SKATING ADJUSTMENT

Rotate the ANTI-SKATE knob in the direction of the arrow in Fig. 17, and set the value which is identical to the applied tracking force to the index line.

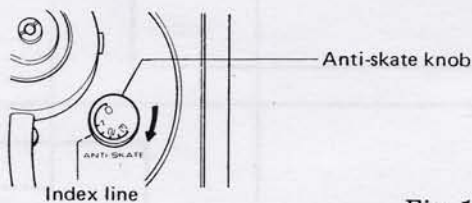

Fig. 17

ANTI-SKATING MECHANISM

When a record is being played, the stylus is drawn toward the inside of the sound grooves (skating force) by the rotations of the record. This downgrades the tracking ability of the right channel, increases the distortion and has other adverse affects on the reproduced sound. What the anti-skating mechanism does is to apply a force in the opposite direction that cancels out the skating force.

TONEARM HEIGHT ADJUSTMENT

If the tonearm and the platter are not both parallel when a record is being played, the cartridge stylus will not come into contact with the sound grooves on the record at the right angle and this may result in distortion of the reproduced sound. Perform the adjustments below as follows;

Adjusting the tonearm height

1. Place a record on the platter.
2. Use one hand to support the tonearm, and the other hand to loosen the adjustment screw with the coin. Place the stylus on the record lightly not to damage, and adjust the tonearm so that it is parallel to the record on the platter and then tighten the adjustment screw (Fig. 18).

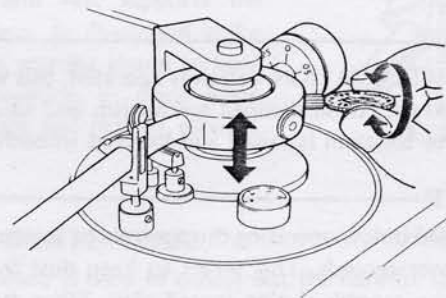

Fig. 18

Adjusting the arm rest height

Use the accessory screwdriver to loosen the arm rest's set screw (Fig. 19). Adjust the arm rest so that the tonearm and the panel are parallel, and then tighten the set screw.

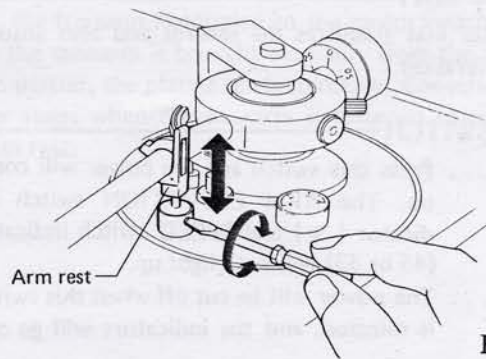

Fig. 19

Adjusting the arm lifter height

Set the POWER switch to ON, press the ARM ELEVATION switch and cause the UP (▲) indicator to light up. As in Fig. 20, loosen the arm lifter set screw with the accessory screwdriver, adjust for a clearance between the record and stylus of about 8 mm when the tonearm moves over the platter, and then tighten the set screw.

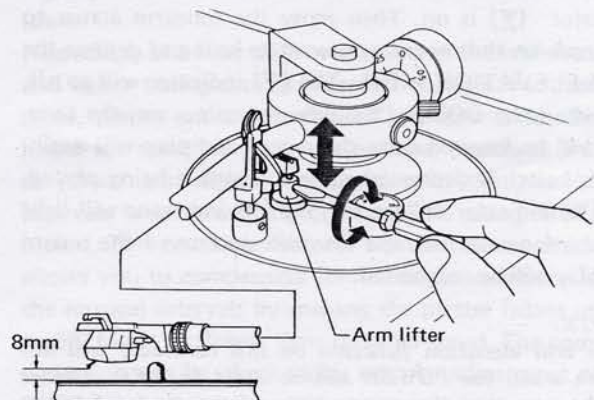

Fig. 20

PANEL FACILITIES

ARM LIFTER

When the ARM ELEVATION switch is operated, this will move up or down. Its oil damped mechanism and spring ensure that the tonearm is raised and lowered smoothly.

DUST COVER

Keep this closed unless operating the controls or tonearm, or changing over records. This serves to keep dust from adhering to the records during record play. When fully opened and pulled straight up, this dust cover can be removed from the cabinet.

PLATTER

When the tonearm is moved and power is supplied to the turntable, the platter will start rotating at the set rotation speed.

PLATTER MAT

This platter mat stabilizes the records and also absorbs external vibration.

POWER SWITCH

ON Press this switch and the power will come on. The ARM ELEVATION switch indicator (▼) and SPEED switch indicator (45 or 33) will both light up.

OFF The power will be cut off when this switch is released, and the indicators will go off.

NOTES:

- The platter will not rotate when the tonearm is on the arm-rest even when the POWER switch is set to ON.
- Always set the POWER switch to OFF when you do not intend to use your turntable.

ARM ELEVATION SWITCH

Use this switch to play a record or to suspend play. It is selected alternately to the UP and DOWN positions. When you want to play a record, check first that the UP indicator (▼) is on. Then move the tonearm across to the track on the record you want to hear and depress the ARM ELEVATION switch. The (▼) indicator will go off, and when the DOWN (▼) indicator comes on, the tonearm will be lowered onto the record and play will begin. If this switch is depressed while a record is being played, the (▼) indicator will go off, the (▼) indicator will light up, the tonearm will rise from the surface of the record and play will be suspended.

NOTE:

The arm elevation function on this turntable will not work when the POWER switch is set to OFF. Always make sure that the power is on when you want to use this function.

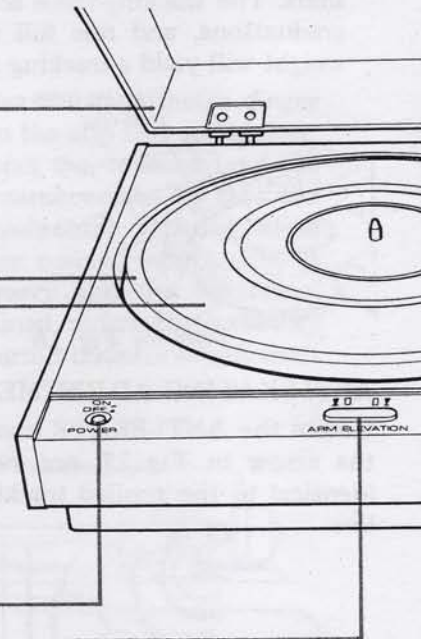

SPEED SWITCH

33 Set the switch to this position when playing a 33-1/3rpm record such as an LP. When it is depressed, the 33 indicator lights up, and the platter rotates at a speed of 33-1/3rpm.

45 Set the switch to this position when playing a 45rpm record like an EP. When it is depressed, the 45 indicator lights up, and the platter rotates at a speed of 45rpm.

QUARTZ LOCK SWITCH

ON When this switch is pressed, the Quartz PLL circuitry is actuated and the indicator will light up. The switch is usually kept at this position. The platter will be accurately locked to the rotational speed corresponding to the position of the SPEED switch.

OFF When this switch is released, the Quartz PLL circuitry is disengaged, the PITCH meter lights up and the indicator goes off. Set the switch to this position for instrumental and other performances in accordance with the record being played. (Refer to the next page "PITCH CONTROL").

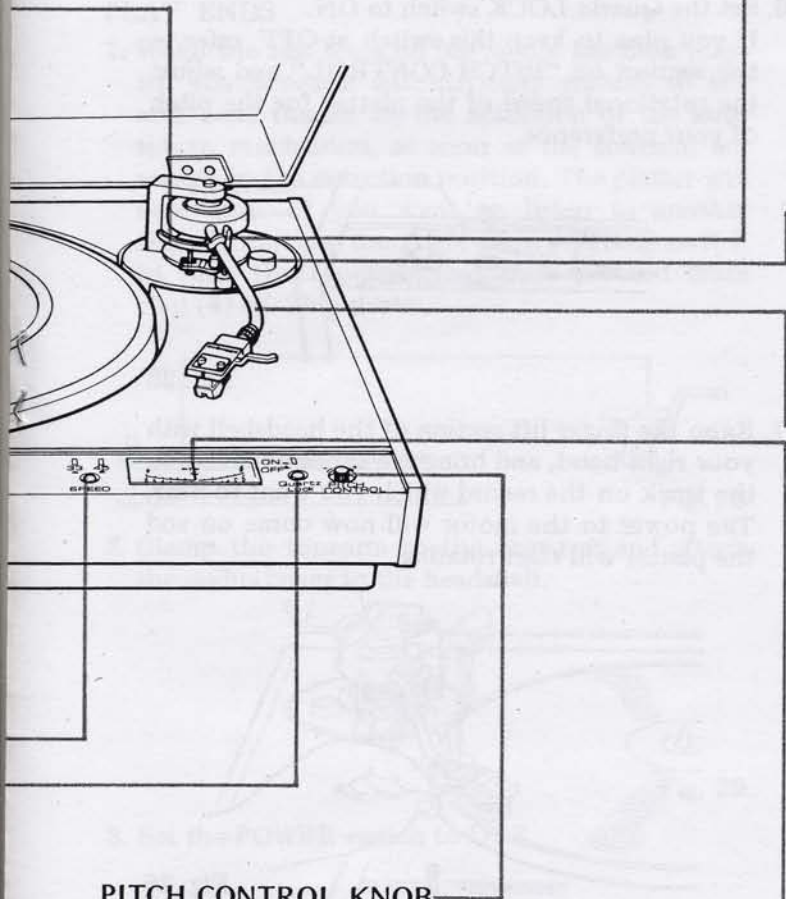

ARM REST

The arm rest supports the tonearm. As illustrated in the figure, use the clamp to keep the tonearm in place when you are not playing records.



ANTI-SKATE KNOB

This knob is used to cancel out the harmful skating force which is generated during record play. For further details, see "ANTI-SKATING ADJUSTMENT on page 7".

TONEARM

This applies just the right amount of tracking force to the cartridge and keeps it steady, thereby allowing the stylus to trace the sound grooves on the record faithfully. What's more, the tonearm is coupled to the motor switch and so when the tonearm is brought manually from the arm rest to the platter, the platter starts to rotate. Conversely, the platter stops when the tonearm is returned manually to the arm rest.

PITCH CONTROL KNOB

If this knob is rotated with the Quartz LOCK switch at OFF, you will be able to increase or decrease the speed of the platter in respect to its rating. When the knob is rotated in the "+" direction, the platter will rotate faster, and when rotated in the "-" direction, it will rotate slower than its rating. The PITCH meter can be observed to check the amount of speed increase or decrease (up to 6% in either case). For further details, see the "PITCH CONTROL".

PITCH METER

When the Quartz LOCK switch is set to OFF, the PITCH meter lamp will light up, and the variation in the rotational speed of the platter in respect to its rating (33-1/3 or 45rpm) can be read out on the meter.

PITCH CONTROL

In normal circumstances, the platter rotates at the rated speed when the Quartz LOCK switch is kept at ON. If you want to vary the speed, set this switch to OFF and turn the PITCH CONTROL knob. If the platter rotates faster than its rated speed, the musical intervals of the reproduced sound will become higher, and if it rotates slower, they will become lower.

Nowadays, there are slight variations in the orchestra and other tuning sounds recorded on discs. Furthermore, pianos and other musical instruments for the home are tuned to high international standards and so there are slight discrepancies in the musical intervals when practicing on the piano along with a record. This turntable features a pitch control which allows you to compensate for the slight variations in the musical intervals by making the platter rotate up to 6% faster or slower than its rated speed. The compensation can be checked by ear. An adjustment of ±6% is equivalent to about a semitone.

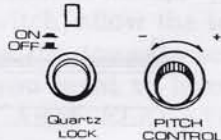
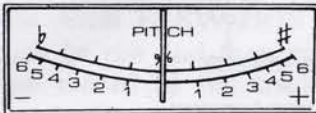

PLAYING PROCEDURE

Check the following before playing a record.

- Set the volume control on the stereo amplifier to its leftmost position and set the POWER switch to ON.
- Set the FUNCTION switch on the stereo amplifier to PHONO.

PLAY STARTS

1. Set the POWER switch to ON.

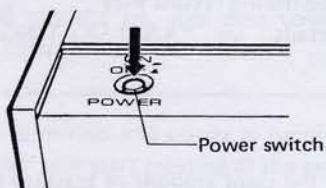

Fig. 21

2. Depress the ARM ELEVATION switch. The tonearm will now rise to the UP position (The right-side arm elevation indicator (▼) now comes on).

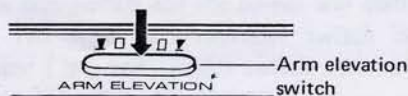

Fig. 22

3. Remove the stylus cover from the cartridge and detach the arm rest clamper.

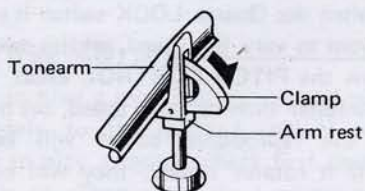

Fig. 23

4. Place the record on the platter (platter mat).
5. Set the SPEED switch in accordance with the speed rating of the record.

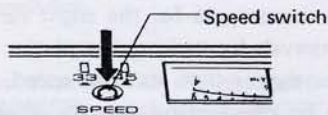

Fig. 24

6. Set the Quartz LOCK switch to ON.

If you plan to keep this switch at OFF, refer to the section on "PITCH CONTROL" and adjust the rotational speed of the platter for the pitch of your preference.

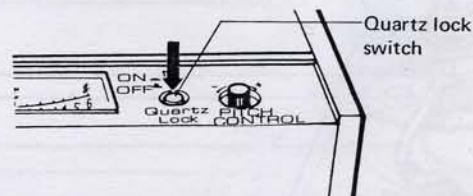

Fig. 25

7. Raise the finger lift section of the headshell with your right hand, and bring the tonearm across to the track on the record which you want to hear. The power to the motor will now come on and the platter will start rotating.

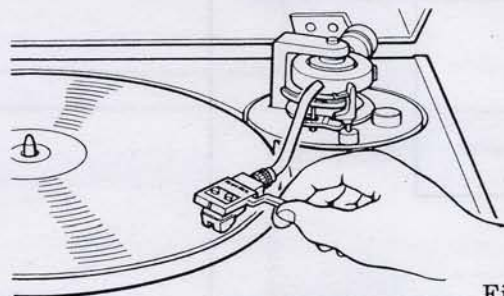

Fig. 26

8. Now depress the ARM ELEVATION switch to lower the tonearm onto the record (The left-side arm elevation indicator (▼) will come on). The tonearm descends gently onto the surface of the record and play begins. Adjust the stereo amplifier's volume control and sit back and enjoy your record.



Fig. 27

PLAY ENDS

1. When the last track on the record has been played, the tonearm automatically returns to the arm rest, thanks to the actuation of the auto return mechanism, as soon as the tonearm advances to the detection position. The platter will now stop. If you want to listen to another record, depress the ARM ELEVATION switch to raise the tonearm, and then proceed from step (4) of 'Play starts'.

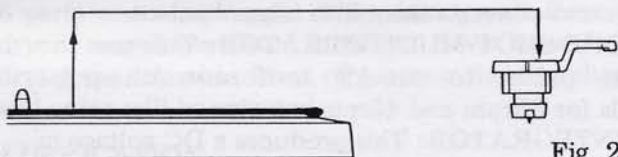

Fig. 28

2. Clamp the tonearm to the arm rest and attach the stylus cover to the headshell.



Fig. 29

3. Set the POWER switch to OFF.

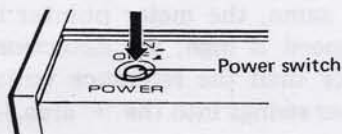

Fig. 30

4. After cleaning your record with a suitable cleaner, put it back in its jacket.

NOTE:

The auto return mechanism may not function normally if you plan to play a record whose size is not standardized. In cases like this, bring the tonearm back to the arm rest by hand.

SUSPENSION OF PLAY

- If you want to suspend the play of a record or listen to another record instead, depress the ARM ELEVATION switch and allow the tonearm to rise and then return it to the arm rest manually. If it is brought back to the arm rest, the platter will stop rotating.
- If you want to listen to a different track, depress the ARM ELEVATION switch, allow the tonearm to rise and then move the tonearm across the record to the track you want to hear by hand. Then depress the ARM ELEVATION switch and start play.

TIMER PLAY

If you use a timer and set it as instructed below, the turntable will play a record automatically at the preset time.

1. Press the ARM ELEVATION switch and set it to UP.
2. Move the tonearm over the record by hand.
3. Set the timer switch as instructed in the timer's "Operating Instructions" so that the turntable and stereo amplifier will operate at the time you want to listen to the record.

When the timer is actuated, and the POWER switches of the amplifier and turntable are set to ON, the tonearm will automatically descend and play will begin.

PRECAUTIONS FOR PLAY

- Before and after play, clean the stylus with a brush. It is also a good idea to clean your records with a good quality cleaner.
- Place one record at a time on the platter. If two or more records are stacked on the platter, the stylus will not make proper contact with the sound grooves, and this will therefore impair the performance.
- Do not cause the turntable to vibrate during record play. This causes the stylus to jump grooves and it damages not only the stylus tip but also the record.
- Do not switch off the amplifier's power or stop the platter rotating by unplugging the power cord during record play. These actions damage the stylus and record.
- Do not hold the platter during record play or touch the tonearm while it is moving. These actions can cause a breakdown.
- Always remember to switch the power off after you have finished playing your records.

OPERATION PRINCIPLE OF QUARTZ PLL DD MOTOR

1. QUARTZ OSCILLATOR: This is minimally affected by ageing and by variations in the temperature and humidity. It generates a reference signal by which the speed of the phono motor is controlled.

2. FREQUENCY DIVIDING CIRCUIT: This divides the frequency of the reference signal generated by the quartz oscillator.

3. SPEED SELECTION FREQUENCY DIVIDING CIRCUIT: This divides the signal to a reference frequency corresponding to one of the two platter speeds, 45rpm or 33-1/3rpm. It is this signal against which the signal from the frequency generator will be compared.

4. MAGNETIC PULSE SENSING FREQUENCY GENERATOR: This produces an alternating current corresponding to the rotation speed of the motor.

5. PHASE COMPARATOR: The phase of the signals from the platter frequency generator is compared with the phase of the reference signal obtained from the speed selection frequency dividing circuit. A corrective voltage corresponding to the difference in phase is produced and this is added to the motor drive current to either accelerate or decelerate the platter by the amount required to maintain the rated speed.

6. FREQUENCY COMPARATOR: The frequency of the signal from the platter frequency generator is compared with the reference frequency derived from the quartz oscillator. The comparator enhances the PLL characteristics to deal with motor overcurrent, etc.

7. BI-DIRECTIONAL DRIVE CIRCUIT: This circuit controls the motor speed in response to the control signals which are applied from the phase comparator and frequency comparator.

8. POSITION DETECTOR: The motor contains Hall elements. As the rotor turns, they emit sequential signal voltages. Transistor switching in the bi-directional drive circuit is controlled by these voltages.

9. DIFFERENTIATION CIRCUIT: This differentiates the output signals from the frequency generator and converts them into trigger pulses.

10. ONE-SHOT MULTIVIBRATOR: This uses the trigger pulses to provide uniform-width pulse signals for 33rpm and 45rpm rotation.

11. INTEGRATOR: This produces a DC voltage in proportion to the speed of the DD motor. The DC voltage signals become the detection output signals.

12. REFERENCE VOLTAGE GENERATOR: This yields a reference voltage for comparison with the output signals (detection output) of the differentiation circuit.

13. VOLTAGE COMPARATOR: This compares the reference voltage with the detection output, and the meter is driven by the voltage difference. (When the detection output and the reference voltage are the same, the meter pointer indicates '0'. When the speed is high, the detection output becomes higher than the reference voltage, and the meter pointer swings into the '+' area.)

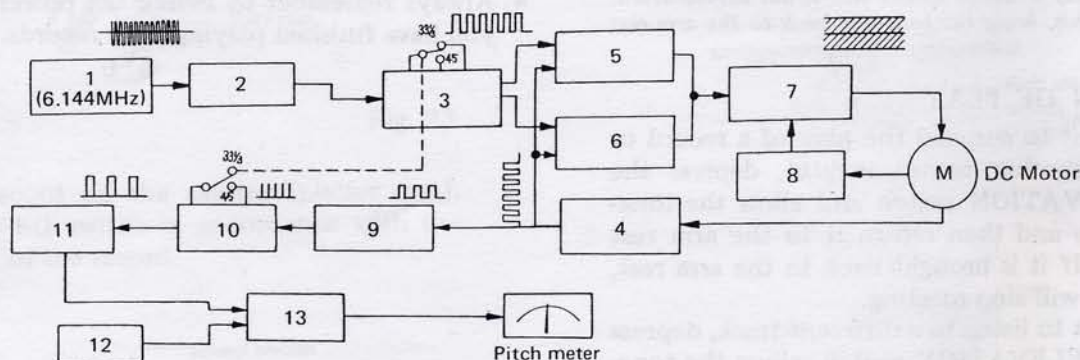

MAINTENANCE

CABINET AND DUST COVER

When the cabinet or dust cover becomes dusty or dirty, wipe it clean with a soft dry cloth. Remember that the surfaces can be corroded by furniture wax, thinners, and benzine and also by insecticide sprays. The dust cover can be detached and cleaned.

RUBBER PLATTER MAT

When the rubber platter mat is dirty, apply a sponge containing one part neutral cleanser to 5 or 6 parts water and wash. After rinsing well, leave to dry in a well-ventilated location. Never leave it to dry in the sun or in front of a heater since its shape and color will be changed.

LUBRICATION

The motor shaft and bearings of this turntable employ oil-less bearings and so there is no need for lubrication. There is no need to lubricate the tone-arm bearings, either.

STYLUS

If the stylus tip is clogged with dust, the reproduced sound quality will be impaired. Use a soft brush to keep the stylus clean at all times. Be careful not to touch the tip since this may damage it. When using stylus cleaner (organic solvent), benzine or thinner to clean the stylus tip, take care not to allow any of the liquid to come into contact with the stylus holder. This may damage the material.

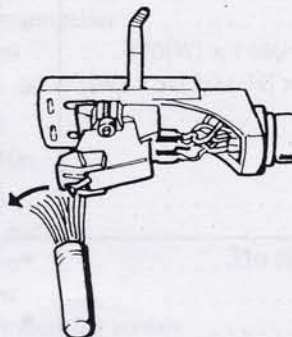

Fig. 31

TROUBLE? CHECK IT OUT

Sometimes an operational fault can be mistaken for an equipment malfunction. Before bringing your turntable in for service, check the points described below. Then, if the problem has not been resolved, contact your nearest Pioneer dealer.

<ul style="list-style-type: none"> • Platter does not rotate. 	<ul style="list-style-type: none"> • Power source is unplugged. → Plug firmly into AC outlet. (If the cord is plugged into a switched AC outlet on your stereo amplifier, turn the power switch on.)
<ul style="list-style-type: none"> • No sound is produced. 	<ul style="list-style-type: none"> • Phono cable is unplugged or improperly connected. → Connect phono plugs firmly to the correct input terminals. (Refer to page 5.) • Headshell is not properly attached. → Firmly tighten locking collar. (Refer to page 4.) • Cartridge lead wires are loose. → Insert pins firmly. (Refer to page 3.) (Make sure amplifier is being properly operated: the function switch is set to PHONO, the tape monitor switch is off, and the volume is sufficient, etc.)
<ul style="list-style-type: none"> • Musical tempo is off. 	<ul style="list-style-type: none"> • Record speed is not set properly. → Set the SPEED switch to the correct position (33 or 45). (Refer to page 8.) • Quartz LOCK switch is OFF. → Push it on.
<ul style="list-style-type: none"> • Excessive noise is produced. 	<ul style="list-style-type: none"> • Ground lead is disconnected. → Connect it properly. (Refer to page 5.) • Record surface is dusty or dirty. → Clean with good quality cleaner. • Dust has collected on stylus. → Clean stylus. • Tracking force is too low. → Adjust to the proper tracking force. (Refer to page 6.) (When noise is produced even when the stylus is not in a record groove, the turntable is being affected by the amplifier or some other electrical equipment. Reconsider the location of the turntable and other components.)
<ul style="list-style-type: none"> • Sound is distorted. 	<ul style="list-style-type: none"> • Stylus is worn. → Replace with new stylus. • Dust has collected on stylus. → Clean stylus. • Tracking force is too low. → Adjust to the proper tracking force. (Refer to page 6.)

Feedback howl: Phenomenon caused when sound from speakers is conducted back to the cartridge via the air or other conducting structure to be amplified again to an extremely loud level. If this should occur, immediately turn off the stereo amplifier and relocate the turntable on a firm support where it is not subject to vibration.

SPECIFICATIONS

Moter and Turntable

Drive System	Direct-drive
Motor	Quartz PLL Hall motor
Turntable Platter	330mm diam. aluminum alloy die-cast
Inertial Mass	340kg-cm ² (including platter mat mass)
Speeds	33-1/3 and 45 rpm
Speed Control Range	±6%
Wow and Flutter	Less than 0.025%(WRMS)
Signal-to-Noise Ratio	More than 75dB (DIN-B) (with Pioneer cartridge model PC-600)

Rotational Characteristics

Build-up Time	Within 90° rotation at 33-1/3 rpm
Speed Deviation	Less than 0.002%
Speed vs. Load Characteristics	Stable up to 200 grams drag load
Speed Drift	Less than 0.00008%/h at 33-1/3 rpm Less than 0.00003%/degree temp. change at 33-1/3 rpm

Tonearm

Type	Static-balance type, S-shaped pipe arm
Effective Arm Length	237mm
Overhang	15mm
Usable Cartridge Weight	4g (min.) to 12.5g (max.) (For cartridge weights over 8.5 grams, attach the sub weight)
Arm Height Adjust Range	±3mm

Subfunctions

- Auto-return
- Quick play
- Quick stop
- Anti-skating force control
- Stylus pressure direct-readout counterweight
- Arm height adjusting device
- Cueing device
- Pitch meter
- Free stop hinges

Semiconductors

ICs	6
Transistors	17
Diodes	9
Hall Elements	3
LED	5
Photo Transistor	1
CdS	1

Miscellaneous

Power Requirements	AC 120V 60Hz
Power Consumption	22W
Dimensions	.470(W) x 148(H) x 418(D) mm 18-1/2(W) x 5-13/16(H) x 16-7/16(D) in.
Weight	12kg/26lb 7oz

Accessories

EP adaptor	1
Overhang gauge	1
Screwdriver	1
Sub weight	1
Cartridge mounting screws	6
Cartridge mounting nuts	2
Cartridge mounting washers	2
Operating instructions	1

NOTE:
Specifications and design subject to possible modification without notice, due to improvements.

IMPORTANT NOTICE

Please read this manual carefully and keep it handy for reference. Do not use this product if you find it damaged or if it does not work properly.

WARNING: TO PREVENT FIRE OR SHOCK HAZARD, DO NOT EXPOSE THIS APPLIANCE TO RAIN OR MOISTURE.

