

CUSTOM SPEAKER SYSTEM KIT AS-200 ASSEMBLY INSTRUCTIONS

The PIONEER AS-200 is a "do-it-yourself," kit for a custom 20cm(8-inch) 2way 2-speakers system for use in high fidelity sound systems.

It is comprised of carefully-matched units chosen from PIONEER'S extensive range of quality speakers, put together in an compact system for high fidelity sound reproduction.

WORLD-FAMOUS BRAND IN HI-FI REPRODUCTION
PIONEER®

AS-200

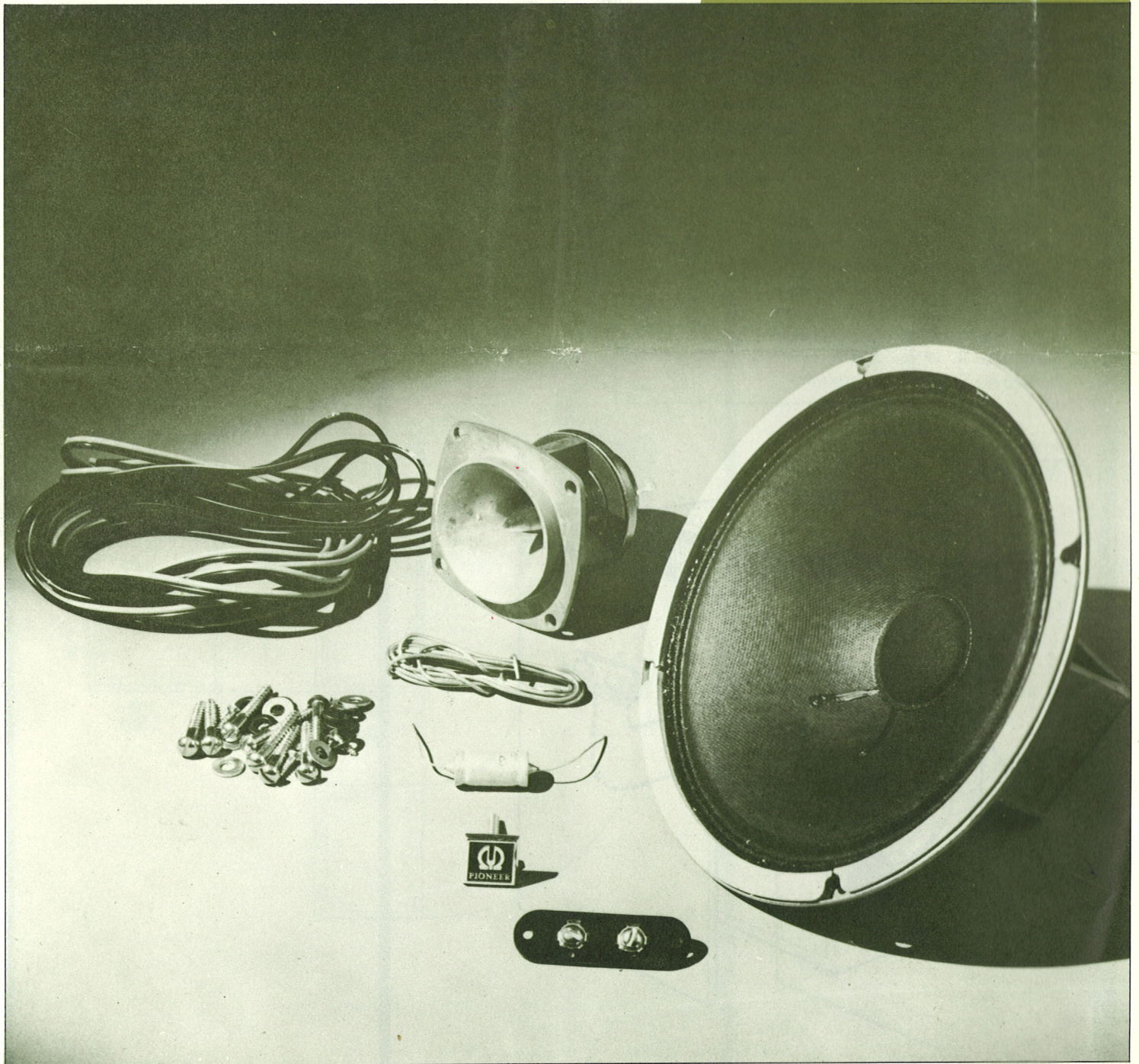

 PIONEER ELECTRONIC CORPORATION

* Assembly Instructions for Hi-Fi Speaker System AS-200

● Wiring of AS-200

Fig.1 shows the wiring diagram and Fig.2 illustrates the pictorial diagram of the AS-200 completely assembled. Since the wiring cords furnished with the AS-200 are color coded, it is a good practice to use the red cord exclusively for the wiring of the potential-existing lines. Such wiring will be a great help in checking the finished wiring later. For ease of wiring, the two loudspeakers may be mounted in advance on the front baffle board of your speaker enclosure. For connecting wires to terminals, wind the wire around the terminal two or three turns and solder the joint quickly and neatly. Applying the hot soldering iron onto the terminal for long may cause serious damage.

Fig 1

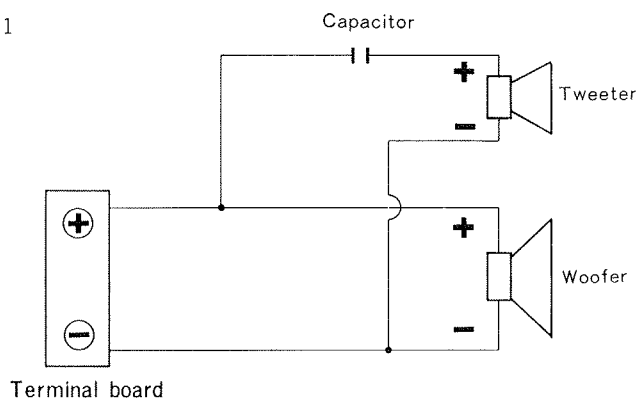

● Notes on Speaker Installation

When the speakers are mounted in the speaker enclosure, be sure that you use the spring washer and flat washer with the mounting screws. These mounting hardware are furnished with the AS-200. When tightening screws, it is not recommendable to tighten completely one screw and go onto the next. Good practice is to equally tighten all screws to a certain degree and then go over tightening the screws a little further. Repeat the step until all screws are completely and securely tightened. When all screws have been tightened, secure them with daubs of paint or glue.

Fig 2

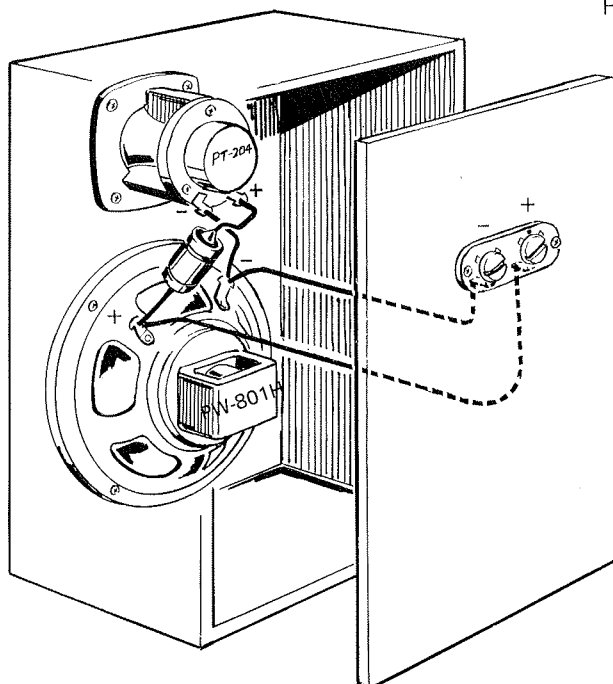

● **Speaker Enclosure Dimensions**

The enclosure shown in Fig.3 is of a standard type. In this figure, the inside dimensions or the internal volume of the enclosure is the most critical since it is delicately related to the performance of the loudspeakers. If you plan it to use boards thicker than what are shown 9.5mm(3/8") in the drawing, the outside dimensions should be made larger than those shown in the drawing by what ever the difference in thickness is. Avoid to use boards of which the thickness is less than 9.5mm(3/8").

● **Notes on Making Speaker Enclosure**

Hard and well-dried boards thicker than 9.5mm (3/8 inch) should be used as the material to build the enclosure with. For fitting boards at the corners, see Fig.4. In any case, the enclosure must be built so as to provide a good air-tightness when assembled. Wherever reinforcement is required, an appropriate angle block may be applied, referring to Fig.5. It is important that the front baffle board on which the loudspeakers are to be mounted is not warped nor uneven. It must be flat and smooth in surface. If the loudspeakers are mounted on a warped board, they may be slightly twisted when installed. Such installation may cause serious damage to the loudspeakers. It may be recommendable to paint the front side (which will be covered by the grille cloth later) of the front baffle board in the same color (light black) with the loudspeaker's cone so that the openings for the loudspeakers may not be discerned from the outside after the grille cloth is set on the front baffle board. However, such painting may not be necessary if the color and material of the grille cloth are appropriately selected.

Fig 3

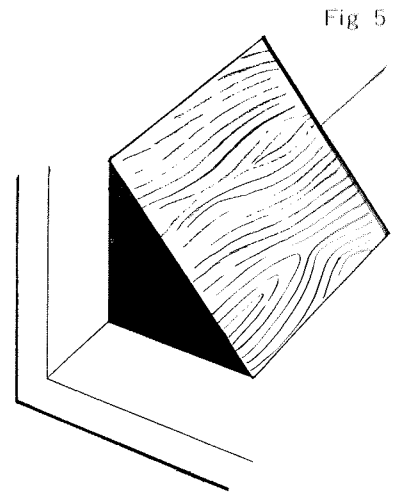
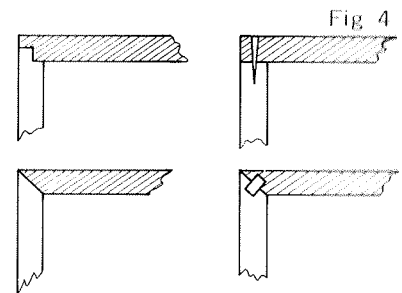
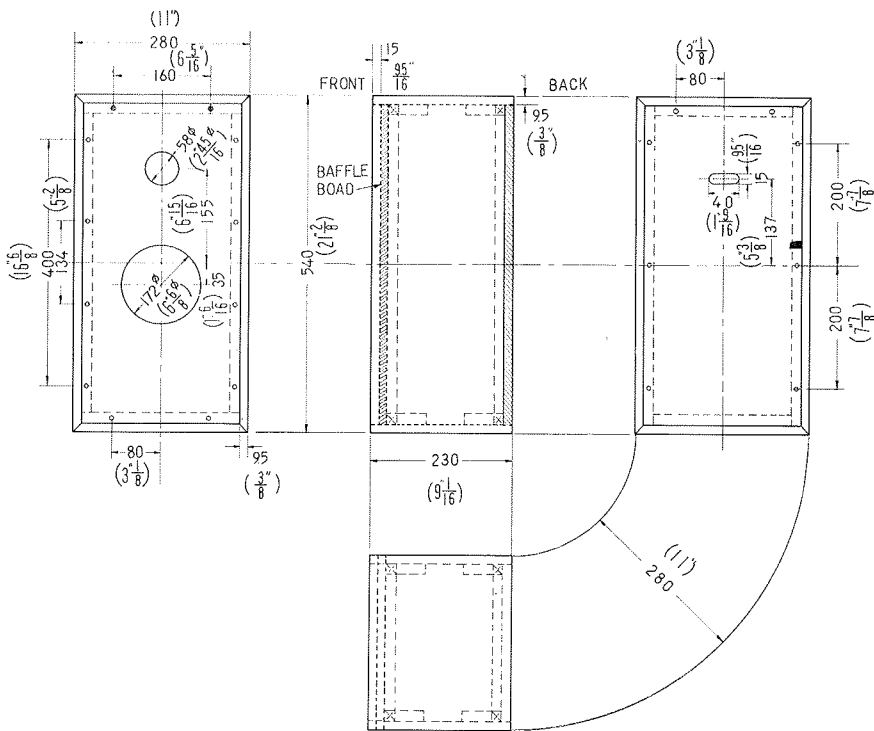

● Grille Cloth

The grille cloth covering the front panel of the enclosure has a considerable influence on the acoustic performance of the speaker system, in particular, the reproduction of high frequencies. Avoid to use fine-woven, thick grille cloth, for such cloth has a poor characteristic in passage of high frequencies. Coarse-woven, hard, and thin grille cloth may be suitable for this purpose.

● Specifications

(The loudspeakers are installed in the enclosure of the standard dimensions.)

Impedance	8Ω
Frequency response	40 ~ 20,000Hz
Maximum input power	25W
Sensitivity	95dB/W
Speakers weight Woofer (PW-801H)	1.5kg (55oz)
Tweeter (PT-204F)	450gr (16oz)
Crossover Frequency	5,000Hz
Rate of Attenuation	6dB/octave

● Sound Absorbent

The inside walls of the enclosure should be lined with sound absorbent such as felt or glass wool. Fig.6 may assist you in lining the walls with sound absorbent. Be sure that well-dried absorbent be used for this purpose.

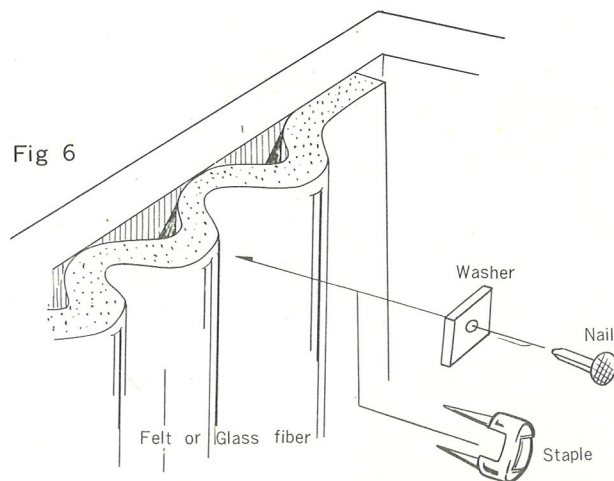

● Contents of AS-200

1. 20cm (8") woofer (PW-801H)	1 each
2. Horn tweeter (PT-204F)	1 each
3. Capacitor 3μF	1 each
4. Wiring cords	
5. Terminal board	1 each
6. Mounting screws for speakers	1 set

PIONEER ELECTRONIC CORPORATION

15-5, 4-Chome, Ohmori-nishi, Ohta-ku, Tokyo, Japan

U.S. PIONEER ELECTRONICS CORPORATION

178 Commerce Road, Carlstadt, New Jersey 07072 U. S. A.

PIONEER ELECTRONIC (EUROPE) N.V.

Noorderlaan 83, 2030 Antwerp, Belgium

PRINTED IN JAPAN
<R12-608-B>

AS-200 Pattern of Baffle Board

(Size – Fullscale)

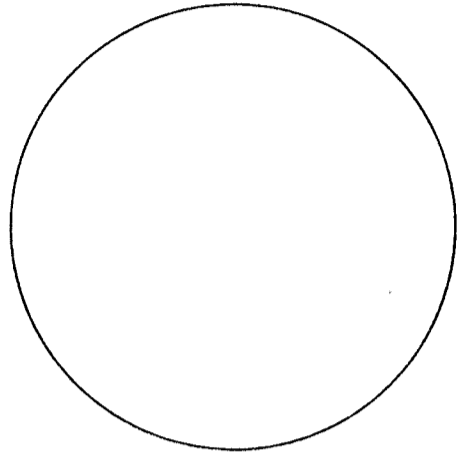

Note: Print both templates in full (1:1) size, and align/overlap them using the cutout lines as guide. Tape or glue together for full-size template. (Donor's instructions).

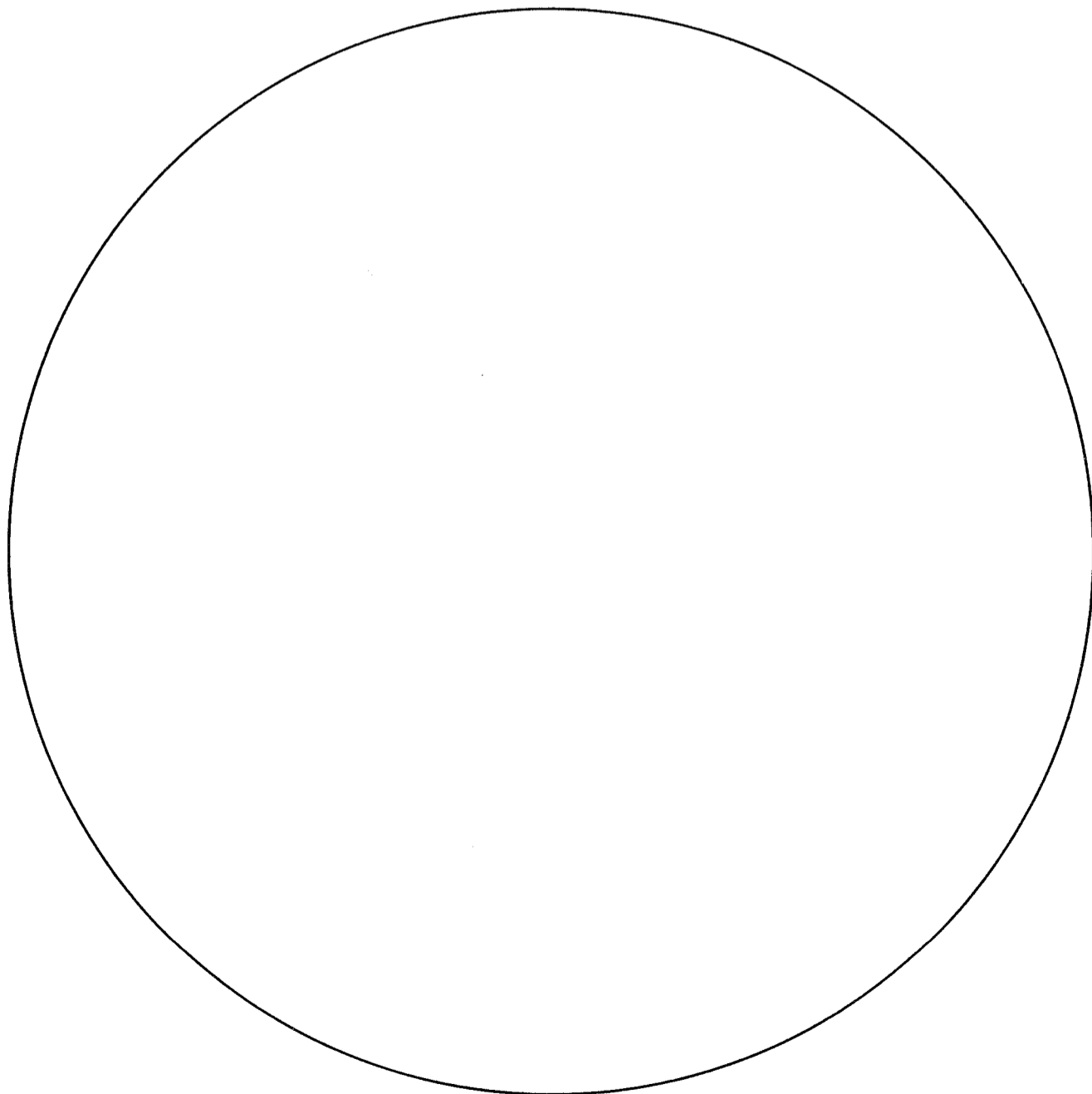

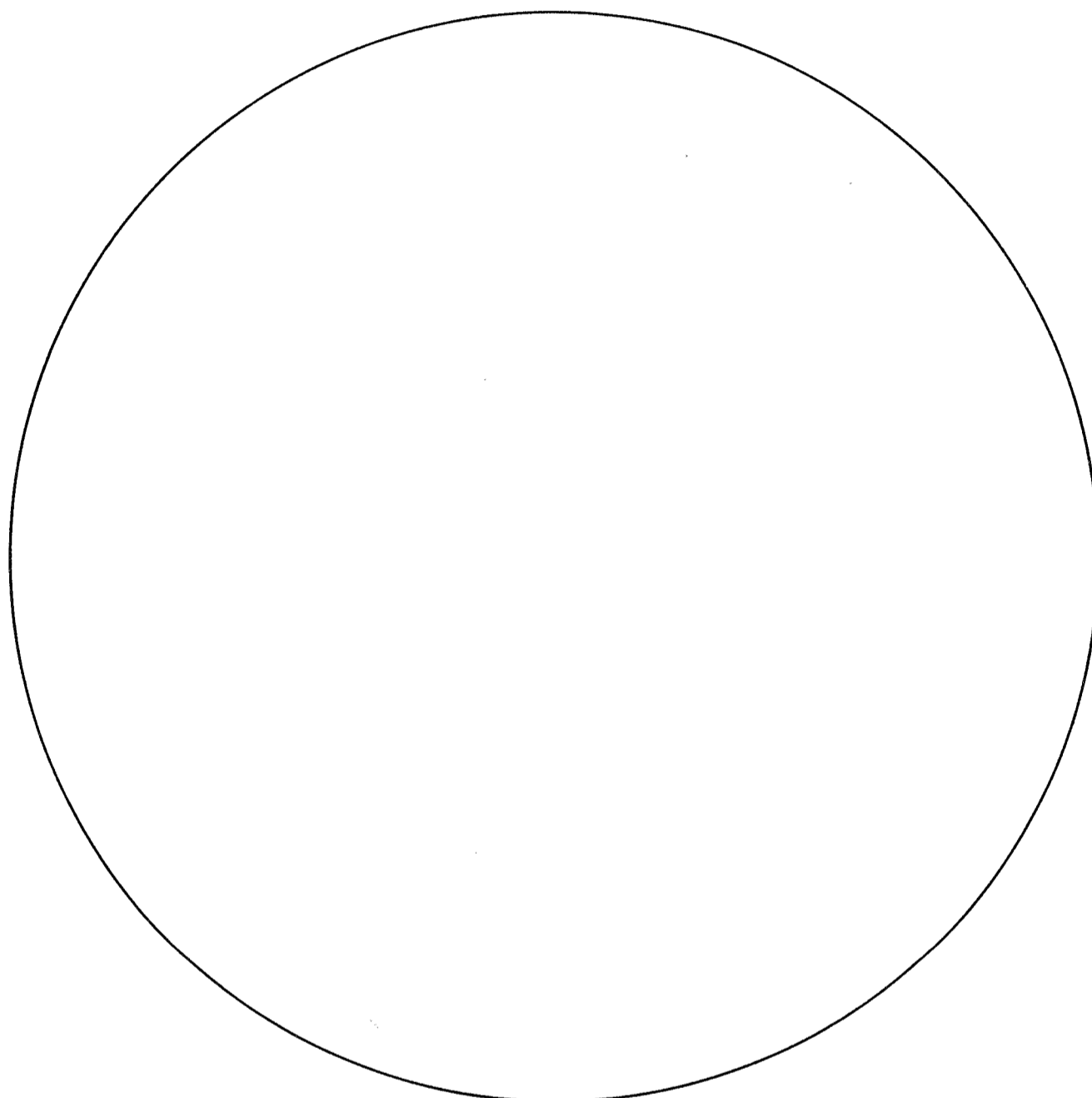

PIONEER ELECTRONIC CORPORATION