

Artistry in Sound
ONKYO

TX-SV515PRO

Audio Video Control Tuner Amplifier

Instruction Manual

● *Congratulations on your purchase of the ONKYO TX-SV515PRO Tuner-Amplifier.* ● *Please read this manual thoroughly before making connections and turning power on.* ● *Following the instructions in this manual will enable you to obtain optimum performance and listening enjoyment from your new TX-SV515PRO.* ● *Please retain this manual for future reference.*

CONTENTS

Important safeguards	1
Precautions	2
Before using this unit.....	2
Features.....	3
Explanation	4
System connections.....	5
Control positions and names	9
Operations.....	11
Use of Surround mode.....	16
Listening to devices connected to the TX-SV515PRO in another room.....	17
Troubleshooting guide	18
Specifications	19

CAUTION:

"TO REDUCE THE RISK OF ELECTRIC SHOCK, DO NOT REMOVE COVER (OR BACK). NO USER-SERVICEABLE PARTS INSIDE. REFER SERVICING TO QUALIFIED SERVICE PERSONNEL."



CAUTION
RISK OF ELECTRIC SHOCK
DO NOT OPEN



- The lightning flash with arrowhead symbol, within an equilateral triangle, is intended to alert the user to the presence of uninsulated "dangerous voltage" within the product's enclosure that may be of sufficient magnitude to constitute a risk of electric shock to persons.



- The exclamation point within an equilateral triangle is intended to alert the user to the presence of important operating and maintenance (servicing) instructions in the literature accompanying the appliance.

Important safeguards

- 1. Read Instructions** – All the safety and operating instructions should be read before the appliance is operated.
- 2. Retain Instructions** – The safety and operating instructions should be retained for future reference.
- 3. Heed Warnings** – All warnings on the appliance and in the operating instructions should be adhered to.
- 4. Follow Instructions** – All operating and use instructions should be followed.
- 5. Water and Moisture** – The appliance should not be used near water - for example, near a bathtub, washbowl, kitchen sink, laundry tub, in a wet basement, or near a swimming pool, and the like.
- 6. Carts and Stands** – The appliance should be used only with a cart or stand that is recommended by the manufacturer.
- 6A.** An appliance and cart combination should be moved with care. Quick stops, excessive force, and uneven surfaces may cause the appliance and cart combination to overturn.

PORTABLE CART WARNING



S3125A

- 7. Wall or Ceiling Mounting** – The appliance should be mounted to a wall or ceiling only as recommended by the manufacturer.

"WARNING"

"TO REDUCE THE RISK OF FIRE OR ELECTRIC SHOCK, DO NOT EXPOSE THIS APPLIANCE TO RAIN OR MOISTURE."

- For models having power cords with a polarized plug.

CAUTION: TO PREVENT ELECTRIC SHOCK, MATCH WIDE BLADE OF PLUG TO WIDE SLOT, FULLY INSERT.

- Sur les modèles dont la fiche est polarisée.

ATTENTION: POUR EVITER LES CHOCS ELECTRIQUES, INTRODUIRE LA LAME LA PLUS LARGE DE LA FICHE DANS LA BORNE CORRESPONDANTE DE LA PRISE ET POUSSER JUSQU'AU FOND.

- 8. Ventilation** – The appliance should be situated so that its location or position does not interfere with its proper ventilation. For example, the appliance should not be situated on a bed, sofa, rug, or similar surface that may block the ventilation openings; or, placed in a built-in installation, such as a bookcase or cabinet that may impede the flow of air through the ventilation openings.
- 9. Heat** – The appliance should be situated away from heat sources such as radiators, heat registers, stoves, or other appliances (including amplifiers) that produce heat.
- 10. Power Sources** – The appliance should be connected to a power supply only of the type described in the operating instructions or as marked on the appliance.
- 11. Polarization** – If the appliance is provided a polarized plug having on blade wider than the other, please read the following information: The polarization of the plug is a safety feature. The polarized plug will only fit the outlet one way. If the plug does not fit fully into the outlet, try reversing it. If there is still trouble, the user should seek the services of a qualified electrician. Under no circumstances should the user attempt to defeat the polarization of the plug.
- 12. Power-Cord Protection** – Power-supply cords should be routed so that they are not likely to be walked on or pinched by items placed upon or against them, paying particular attention to cords at plugs, convenience receptacles, and the point where they exit from the appliance.
- 13. Cleaning** – The appliance should be cleaned only as recommended by the manufacturer.
- 14. Power Lines** – An outdoor antenna should be located away from power lines.
- 15. Nonuse Periods** – The power cord of the appliance should be unplugged from the outlet when left unused for a long period of time.

16. **Object and Liquid Entry** – Care should be taken so that objects do not fall and liquids are not spilled into the enclosure through openings.
17. **Damage Requiring Service** – The appliance should be serviced by qualified service personnel when:
 - A. The power-supply cord or the plug has been damaged; or
 - B. Objects have fallen, or liquid has been spilled into the appliance; or
 - C. The appliance has been exposed to rain; or
 - D. The appliance does not appear to operate normally or exhibits a marked change in performance; or
 - E. The appliance has been dropped, or the enclosure damaged.
18. **Service** – The user should not attempt to service the appliance beyond that described in the operating instructions. All other servicing should be referred to qualified service personnel.
19. **Outdoor Antenna Grounding** – If an outside antenna is connected to the receiver, be sure the antenna system is grounded so as to provide some protection against voltage surges and built up static charges. Article 810 of the National Electrical Code, ANSI/NFPA 70, provides information with regard to proper grounding of the mast and supporting structure, grounding of the lead-in wire to an antenna discharge unit, size of grounding conductors, location of the antenna-discharge unit, connection to grounding electrodes, and requirements for the grounding electrode. See Figure 73.1.

FIGURE 73.1:
EXAMPLE OF ANTENNA GROUNDING AS PER NATIONAL ELECTRICAL CODE

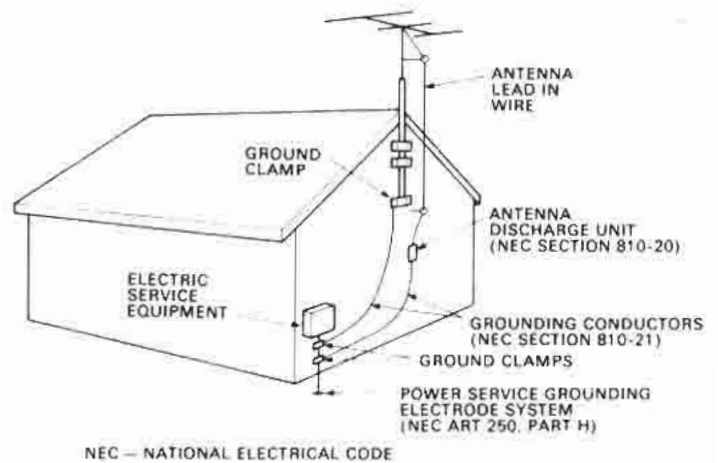

NEC – NATIONAL ELECTRICAL CODE
S2898A

Precautions

1. Warranty Card

The serial number is written on the rear panel of this unit. Copy the serial number and model number onto your warranty card and keep it in a safe place.

2. Recording Copyright

Recording of copyrighted material for other than personal use is illegal without permission of the copyright holder.

3. AC Fuse

The fuse is located inside the chassis and is not user serviceable. If power does not come on, contact your ONKYO service center.

4. Care

From time to time you should wipe off the front and rear panels and the cabinet with a soft cloth. For heavier dirt, dampen a soft cloth in a weak solution of mild detergent and water or a mild ammonia cleaner, wring it out dry, and wipe off the dirt. Following this, dry immediately with a clean cloth. Do not use rough material, thinners, alcohol or other chemical solvents or cloths since these could damage the finish or remove the panel lettering.

5. Power

BEFORE TURNING ON POWER FOR THE FIRST TIME, READ THE FOLLOWING SECTION CAREFULLY.

- Some models are designed for use only with the power supply voltage of the region where they are sold.
 - U.S.A. and Canadian models: AC 120V, 60Hz
 - Worldwide models: 120 and 220V switchable, 50/60Hz

Before using this unit

1. Supplied Accessories

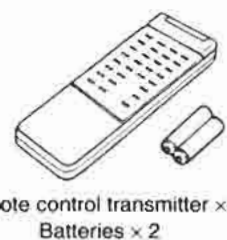
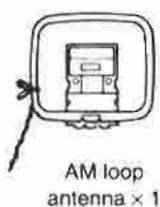

• Voltage Selector (Rear Panel)

Worldwide models are equipped with a voltage selector to conform with local power supplies. Be sure to set this switch to match the voltage of the power supply in your area before turning the power switch on. Voltage is changed by sliding the groove in the switch with a screwdriver to the right or left.

Confirm that the switch has been moved all the way to the right or left before turning the power switch on. Models without a voltage selector can only be used in areas where the power supply is the same as that of the unit.

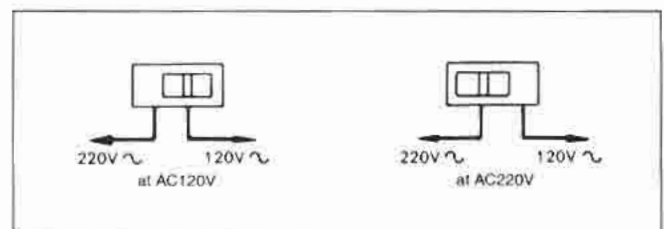

• Tuning Step Frequency Switch (Rear Panel)

Worldwide models are equipped with a switch that controls the AM (9kHz/10kHz) band tuning steps.

Be sure to set this switch to match the tuning step frequency in your area.

2. Transmitter Battery Insertion

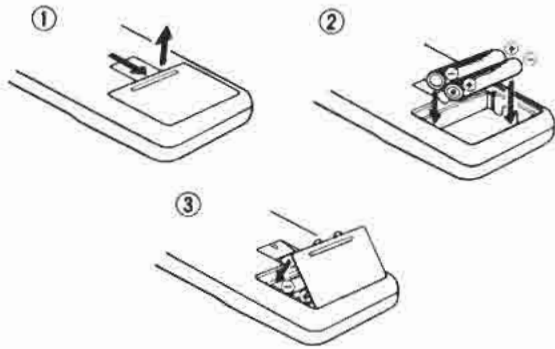

Precautions when using batteries

- The remote control transmitter is powered by two batteries. Before using this unit for the first time, insert the two batteries (included) as shown in the diagram.
- Average battery life is about one year. This period may be shorter depending on the frequency of use and environment (temperature and humidity) in which the remote control transmitter is used.

- If the remote control transmitter does not operate even though front panel controls function normally, the batteries should be replaced. Use only batteries listed in the following chart.

Type	Voltage	Size
Manganese	1.5V	AA R6 UM-3

NOTES:

1. Do not leave an expired battery in the case as it may leak or damage the battery case.
2. When inserting the batteries, be sure the (+) and (-) ends are properly aligned.
3. Do not use nickel-cadmium (rechargeable) batteries.
4. Do not use one specified (manganese) battery and one alkaline Battery at the same time.
5. Replace both batteries at once; do not use one old and one new battery together.

Using the remote control transmitter

1. The batteries of the remote control transmitter must be replaced periodically.
2. This unit uses infrared rays. Therefore, commands may not be received properly if the front panel of this unit is exposed to bright light. To prevent this from occurring, place this unit so that it is not directly exposed to bright light.
3. If this unit is placed inside an audio rack behind a glass door, the door should not have colored glass or have any decorations on it, since this could shorten the range or prevent commands from being received.
4. The transmitter operates up to a distance of about five meters (16 feet). The transmitting window must always be pointed at the reception window when a command is sent to the TX-SV515PRO.
5. If this remote control transmitter does not operate properly, confirm that the batteries are not dead. If the problem persists, contact your ONKYO Service Center.

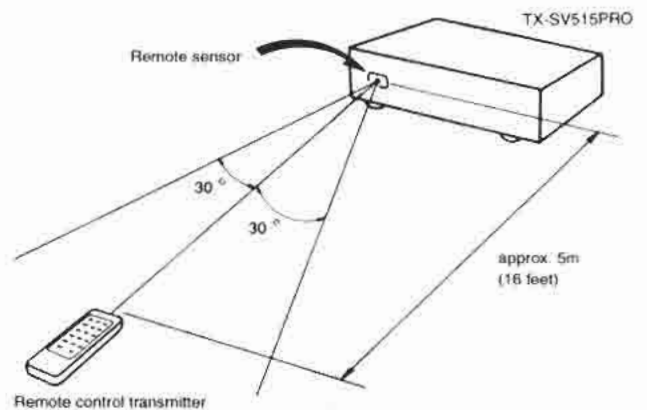

Features

• Plenty of Clean Power

Plenty of continuous power (Front: 80w/ch into 8 ohms with no more than 0.08% THD in stereo mode; Center: 55 watts in surround mode; Rear: 20w/ch in surround mode) and discrete amplifier blocks for each channel of the front, center and rear speakers ensures clean sound from any source.

• Dolby Pro-Logic Surround Sound System

Creates a multi-dimensional soundstage with better channel separation, localization, imaging and dialogue that comes directly from center stage. The result is sound effects comparable to that of high-class theaters.

• Multiple Room Remote System and Multi Source Selector

If you have an additional pair of speakers in another room, you can operate your TX-SV515PRO from the other room (with the optional HR-10W remote sensor), as well as control non-ONKYO video components, such as your TV or VCR from another room (with optional HE-50AC emitter and HE-10 emitter head). You can also play different sources simultaneously for multiple-room entertainment.

• Direct Access Tuning

• 40-Station Random Preset Tuning

• Six-Class Classified Memory

• Connection Facilities for Three Video Components

• Selective Tone Control

• Recording Selector

• RI Compatible Remote Control Included

Explanation

Surround System

Many motion pictures produced in the last decade have been released in "Dolby Stereo" sound, with music, dialogue, and panned effects coming from the 3-channel front soundstage, and surround effects and ambience emanating from the sides and rear of the theater. These four channels are encoded, or matrixed, into a two-channel DOLBY STEREO release, and decoded in the theater by a professional DOLBY STEREO MP (Motion Picture) decoder. These surround sound effects are "hidden" in the two-channel stereo movie release, and decoded in the theater by special Dolby equipment.

These same two-channel motion picture masters are used for production of stereo VHS, VHS Hi-Fi, Beta Hi-Fi, and stereo Laser Vision discs that you can buy or rent at your video store. The TX-SV515PRO incorporates the Dolby Pro Logic Surround Circuit, which is designed to emulate the audience experience found in DOLBY STEREO theaters. Like DOLBY SURROUND, DOLBY PRO LOGIC SURROUND is capable of creating a multi-dimensional soundstage, but with the increased channel separation it gives a far greater sense of "movement" and sound localization. Just like in the theater, the addition of the active center channel ensures that all audience members hear dialogue coming from its on-screen sources regardless of seating position.

Since the TX-SV515PRO is equipped with front amplifiers, center amplifier and rear (surround) amplifiers, Dolby Pro Logic Surround and Hall effects can all be produced. You can enjoy the feeling of a movie theater or concert hall in your own room. To reproduce these effects, rear (surround) speakers and center speaker are necessary. The placement of these speakers is important. You can experiment with various positions and locations to find the best placement for optimum sound quality in your room.

Examples of Speaker Placement

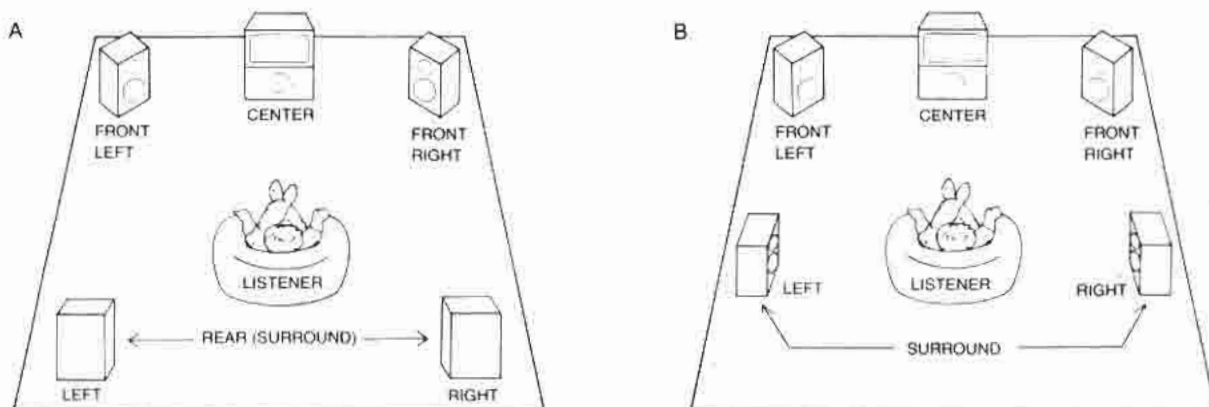

With the rear (surround) speakers facing the wall, the reverberation effect amplifies the "surround" effect for a more "live" sound. Try it and see!

● Dolby Pro Logic Surround

When using a video cassette tape or a video disc that have the DOLBY STEREO or DOLBY SURROUND trade mark, you can achieve the same kind of sound in your room that you experience in a movie theater.

In the Dolby Pro Logic Surround mode, three modes are available according to the type of center speaker used.

1. Normal: When a small speaker is used on the center channel, signals of 100 Hz or more are output from the center speaker, and signals of 100 Hz or less are split between the front L and R channels.
2. Wide band: When the center speaker is approximately the same size as the left and right front speakers, it operates throughout the full frequency range.
3. Phantom: When no center speaker is used, the center channel signal is split between the front L and R speakers, producing the same results as found with a center speaker.

● Hall

The same kind of sound that you experience in a theater or concert hall and the natural expansion of sound can be achieved with a music source. Hall mode would be best suited to jazz and classical.

Multiple Room Remote System (MRR)

The ONKYO HR-10(W) Remote Sensor (sold separately) greatly increases system flexibility. Used with your TX-SV515PRO, the HR-10(W) allows you to control speakers even when you are not in the same room as the TX-SV515PRO. In addition to basic functions like speaker on-off and volume and so on, you can also control most ONKYO CD Players, Cassette Decks and Digital Audio Tape Decks that use the (Remote Interactive) system. Adding an HE-50(AC) Remote Emitter (also available as an option) allows you to control even the non-ONKYO components in your home entertainment system from a separate room.

When the HE-50(AC) is being used to control more than one device from a distance but the infrared beams from the HE-50(AC) remote control transmitter alone will not reach these devices; connect an HE-10 (remote emitter head) to the HE-50(AC), and set it up to be aimed at the devices to be controlled. The HW-2 cable 6-1/2' (2m) is attached with the HE-10. Up to three HE-10 units can be used with this equipment.

Manufactured under license from Dolby Laboratories Licensing Corporation. Additionally licensed under one or more of the following patents: U.S. numbers 3,632,886, 3,746,792 and 3,959,590; Canadian numbers 1,004,603 and 1,037,877. "Dolby" and the double-D symbol  are trademarks of Dolby Laboratories Licensing Corporation.

System connections

Do not plug in the cord until all connections have been made.

General

Always make sure that you connect the left and right channels correctly. Terminals on equipment and cables, when color-coded, usually employ the convention of red for the right channel.

Note to CATV system installer:

This reminder is provided to call the CATV system installer's attention to Article 820-40 of the NEC, which provides guidelines for proper grounding and, in particular, specifies that the cable ground shall be connected to the grounding system of the building, as close to the point of cable entry as practical.

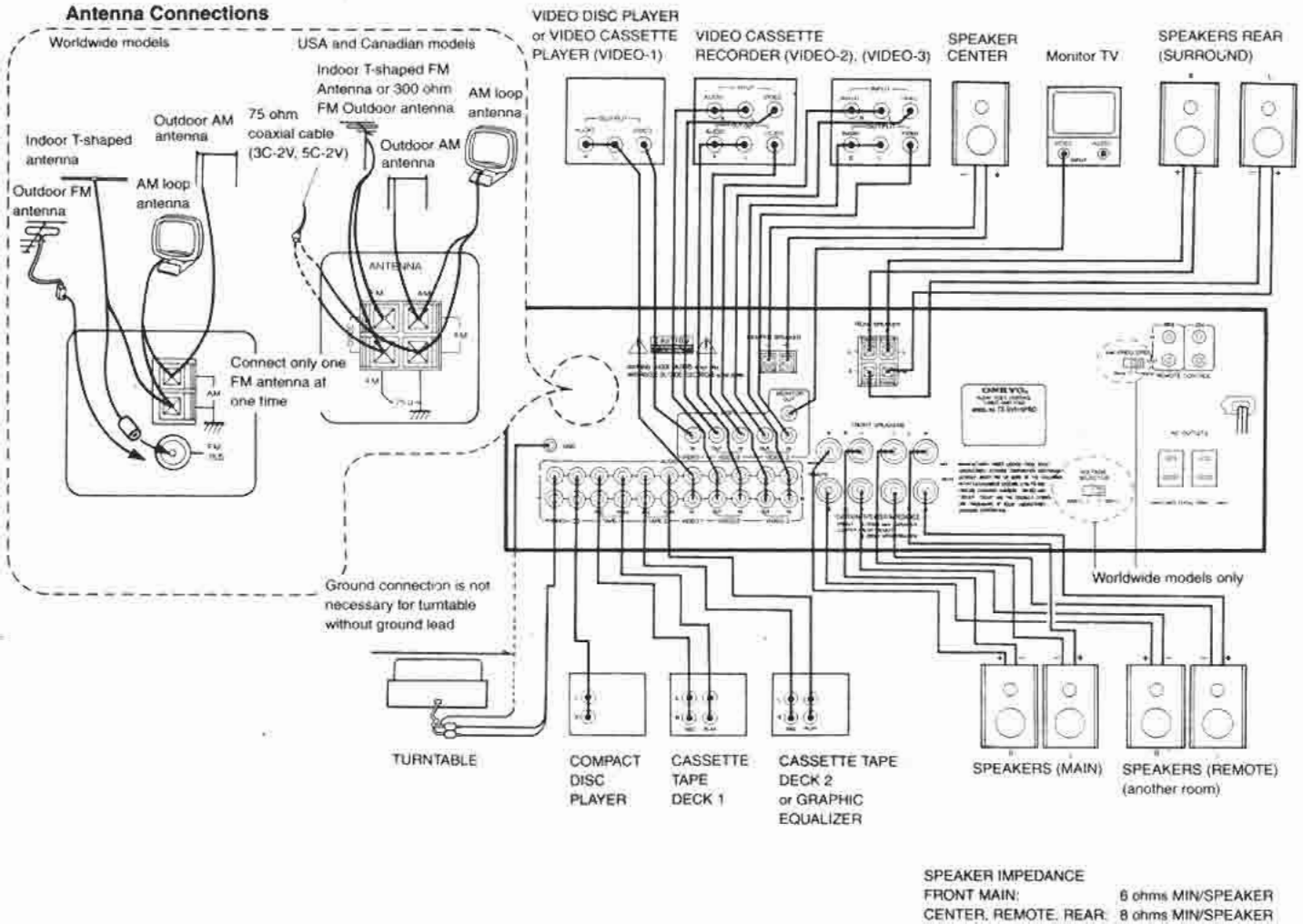

FM Antenna Connections

Use the T-shaped antenna if you live in an area where signal strength of FM broadcasts is high. Connect the antenna to the FM 300 ohms terminals and place the antenna on a wall or other surface in the position in which reception is best. If signal strength is low in your area, use a multi-element FM outdoor antenna and connect to this unit using a 75 ohm coaxial cable because this type of cable is more resistant to interference than 300 ohm cable. Consult your ONKYO authorized service center about the right type of antenna for your area.

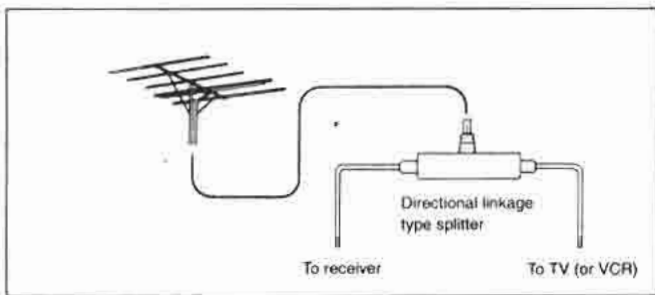

Antenna and Speaker (CENTER and REAR) Connections

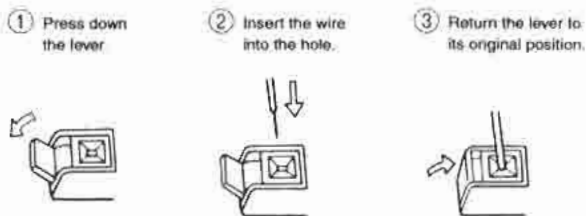

AM Antenna Connections

An AM loop antenna is included in the installation instructions bag. Take out the connection line and connect it to the AM antenna terminals. This loop antenna can be placed on top of any stable surface or attached to a wall. Try several positions to determine which gives the best reception. Be sure the antenna is not near a speaker, power cord, television set, VCR, or motorized appliances. When using an external AM antenna, do not remove the loop antenna; connect both antennas to the AM antenna terminals.

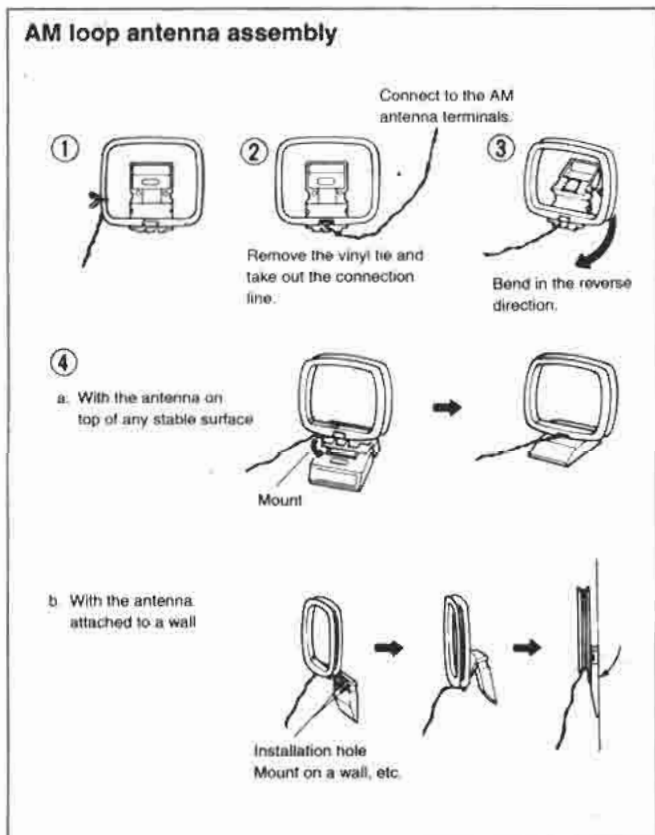

NOTE: AM reception is easily affected by television sets and VCRs. Therefore, AM reception may be poor if this unit is placed too close to a TV or a VCR.

Speaker Connections (SPEAKERS)

- The speakers that are to be in the same room as the TX-SV515PRO should be connected to the "MAIN" speaker terminals. Different set of speakers located in another room (or the same room) should be connected to the "REMOTE" speaker terminals. If you want to use the surround effects, connect the center speaker to the "CENTER" speaker terminals, and the rear (surround) speakers to the "REAR" speaker terminals.
 - When connecting speakers, proper polarity is important. Always connect the (+) terminal (red) on this equipment to the (+) terminal on the speaker and the (-) terminal (black) on this equipment to the (-) terminal on the speaker.
 - Do not connect a single speaker in parallel to the right and left channel outputs.
 - Use speaker cables that have a low impedance and that are as short as possible.
- Attach speaker cables to the rear panel speaker terminals with care, being sure that connections are made firmly and that there is no possibility of a short circuit occurring.

Compact Disc Player or Other Component Connections (CD)

Connect the output of the CD player or an additional audio component to the CD jacks. An ONKYO CD player with remote control that has the **RI** mark can be operated by the TX-SV515PRO. (Please refer to "Connections for Remote Control".) For more details, refer to your CD player instruction manual.

Turntable Connections (PHONO)

Connect the output of the turntable to the PHONO jacks. Be sure to connect the ground (earth) lead wire from the turntable to the ground terminal (GND). Lack of proper ground connection will cause hum. Turntables not provided with GND wires do not need to be connected.

- Place the turntable on a firm shelf or deck free from vibrations (especially those generated by the speaker system). If the turntable is permitted to pick up such unwanted vibrations, not only with the performance of the unit drop, but distortion in the bass frequencies and howling in the speakers may also occur.
- Check the turntable instruction manual for any other precautions.
- The loud noises that occur when connecting or disconnecting, replacing the cartridge or lowering the tonearm could damage the speakers. Always turn the power switch off before making connections.

Tape Deck and Graphic Equalizer Connections (TAPE-1, TAPE-2)

- This unit has facilities for two tape decks. If you are using only one tape deck, connect it to the TAPE-1 jacks. If you have two tape decks, connect one to the TAPE-1 jacks and the other to the TAPE-2 jacks.
- Connect the output of the tape decks to the TAPE-1 and TAPE-2 "PLAY" jacks. Connect the input of the tape decks to the TAPE-1 and TAPE-2 "REC" jacks of the unit. For more details, refer to your tape deck instruction manual.
- To connect a graphic equalizer, too, use the TAPE-2 jacks and connect the second tape deck to the tape jacks of the equalizer. (See the figure)

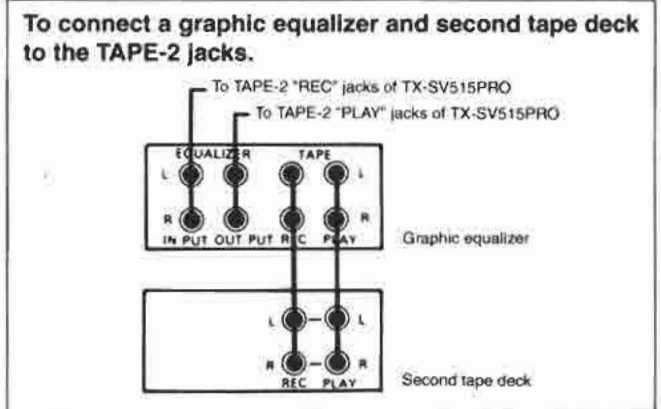

- If you have an ONKYO tape deck with the **RI** remote control jack, connect it to the TAPE-1 jacks. Please refer to the section "Connections for Remote Control" regarding connection of the remote control cable.

Video Disc Player (or Video Cassette Player) Connections (VIDEO-1)

Connect the VIDEO output of the video disc player to the TX-SV515PRO (VIDEO) VIDEO-1 "IN" jack and the AUDIO output to the (AUDIO) VIDEO-1 "IN" jack. The VIDEO-1 jack is only for playback, there is no OUT jack. For more details, refer to the video disc player instruction manual.

Video Cassette Recorder Connections (VIDEO-2, 3)

1. Connect the VIDEO output of the VCR to the rear panel (VIDEO) VIDEO-2, 3 "IN" jack and the VIDEO input of the VCR to the rear panel (VIDEO) VIDEO-2, 3 "OUT" jack. Then connect the AUDIO output of the VCR to the (AUDIO) VIDEO-2, 3 L and R "IN" jacks. Finally, connect the AUDIO input of the VCR to the (AUDIO) VIDEO-2, 3 L and R "OUT" jacks.
2. When using a playback-only VCR, only the output connections need to be performed.
3. For more details, refer to the VCR instruction manual.

TV Connections (MONITOR)

1. Connect the TV VIDEO input to the TX-SV515PRO "MONITOR OUT" jack. There is no need to perform an audio connection since sound will be sent directly from the TX-SV515PRO to the speaker systems.
2. The TX-SV515PRO does not have an RF converter. Therefore, it can be used with only a monitor TV equipped with a video input jack.
3. Since the television set, tuner (FM/AM) section of this unit can cause interference that may disrupt sound and/or picture quality, the TV and TX-SV515PRO and their respective connection cables should be placed as far apart as possible. The use of a common TV/FM antenna is not recommended (see antenna section).

AC Outlets

● SWITCHED:

These outlets are switched on and off by the Power button on the front panel and remote control transmitter. Capacity is total 120 watts.

Connections for Remote Control (REMOTE CONTROL)

- A cassette tape deck, and compact disc player that have the ONKYO **RI** mark can be operated using the accessory remote control transmitter with the TX-SV515PRO.

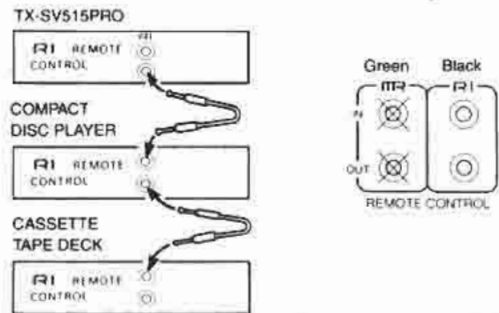

Connect a remote control cable to the black jack with the **RI** mark.

An **RI** remote control cable equipped with a 1/8" (3.5mm) diameter miniature two-conductor phone plug is attached to the TX-SV515PRO and to CD player, with the **RI** mark.

To use an ONKYO compact disc player and cassette tape deck with the **RI** mark, insert the accessory remote control cable plug into the REMOTE CONTROL jack. As far as connecting sequence is concerned, it doesn't matter whether the cable is connected from the TX-SV515PRO to the cassette tape deck or to the compact disc player. The remote control transmitter is operated by facing it towards the remote control sensor of the TX-SV515PRO.

NOTES:

- To enable remote control operation, the audio connection cables and the remote control cable should be connected between the units.
- The remote control of the TX-SV515PRO cannot be used to operate an ONKYO turntable.

Connections for Multiple Room Remote Control

- When using only the HR-10 (option) to control TX-SV515PRO in the main room from another room, connect them as shown in Fig. 1. In this case, ONKYO CD player and cassette tape deck bearing the **RI** mark connected to the TX-SV515PRO can be controlled.

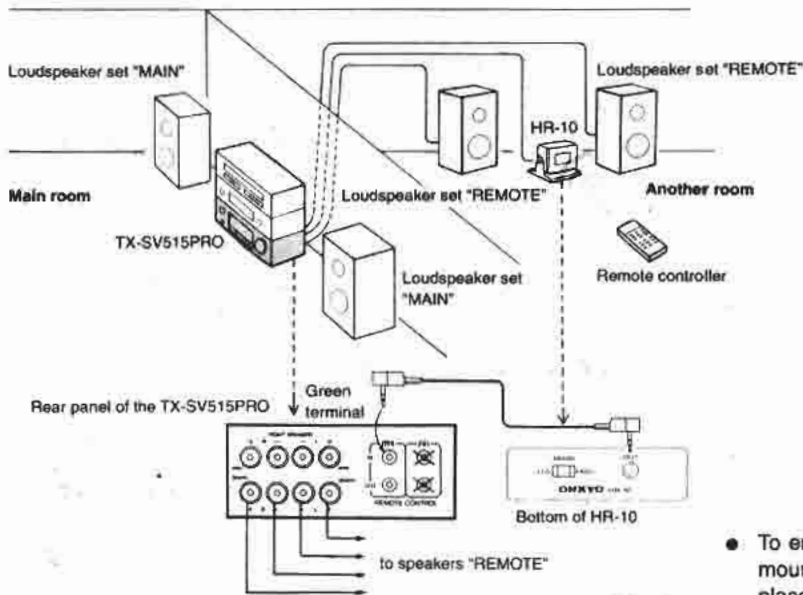

Fig. 1

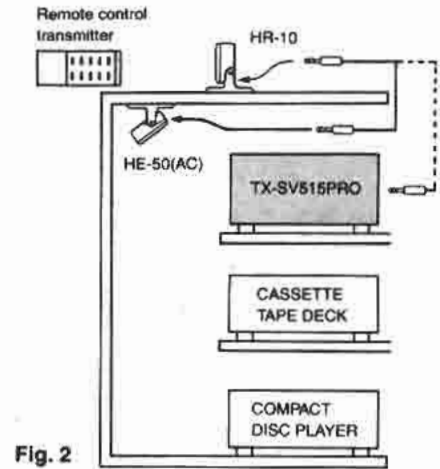

Fig. 2

- To enable remote control operation when the TX-SV515PRO is mounted in a rack which will not permit infra-red beams to pass, place the HR-10 somewhere outside the rack and set the HE-50(AC) in a position which will permit remote control operation of the TX-SV515PRO. The HE-50(AC) is not necessary when utilizing the ONKYO set with the **RI** mark. Please connect the HR-10 and TX-SV515PRO. (see Fig.2)

- A connection example using the HR-10 (option) and HE-50 (AC) (Option) to control components in the main room from another room is shown in Fig. 3.

If all the components can not be controlled by the HE-50 (AC) alone because they are installed at various places in the main room, use the remote emitter head HE-10 (option). In this case, if components possess infrared remote control feature, they can be controlled even if they are not ONKYO products.

NOTE:

When using HE-50(AC), the HE-50 or HE-10 should also face the TX-SV515PRO.

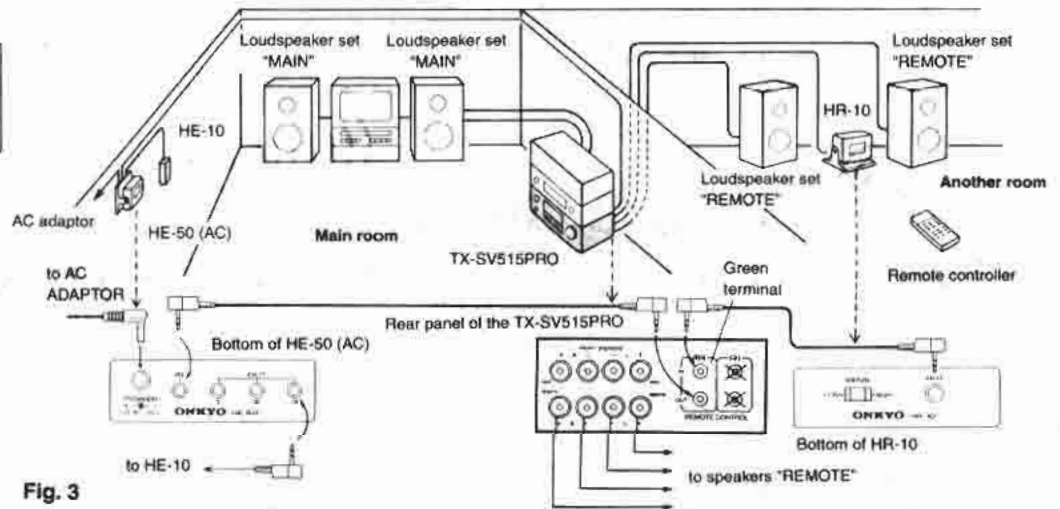

Fig. 3

Remote sensor and emitter (like the HR-10 and HE-50(AC)) should be connected with low capacitance shielded two coaxial cable with mini-plug 1/8" (3.5 mm diameter) connectors. Maximum cable length is determined by the characteristics of the particular cables used but approximately 164' (50 m) lengths are generally practical.

Ready made cable complete with mini-plug connectors are available in the following lengths: 6-1/2' (2m) (HW-2), 98-7/16' (30m) (HW-30), and 164' (50m) (HW-50).

(ONKYO cables may not be sold in some regions.)

Refer to the instruction manual which comes with the HR-10 when making these connections.

Use low impedance cables to connect the TX-SV515PRO in the main room and a set of loudspeakers in another room.

NOTES:

- Always unplug the AC power cords for the TX-SV515PRO and HE-50(AC) when connecting the **RI**.
- Insert the **RI** mini-plug into the GREEN TERMINAL on the rear panel of the TX-SV515PRO.

Control positions and names

Front panel

For more information about buttons or controls, turn to the page number listed in the [].

Speaker Selector Buttons (SPEAKERS MAIN/REMOTE) [11]

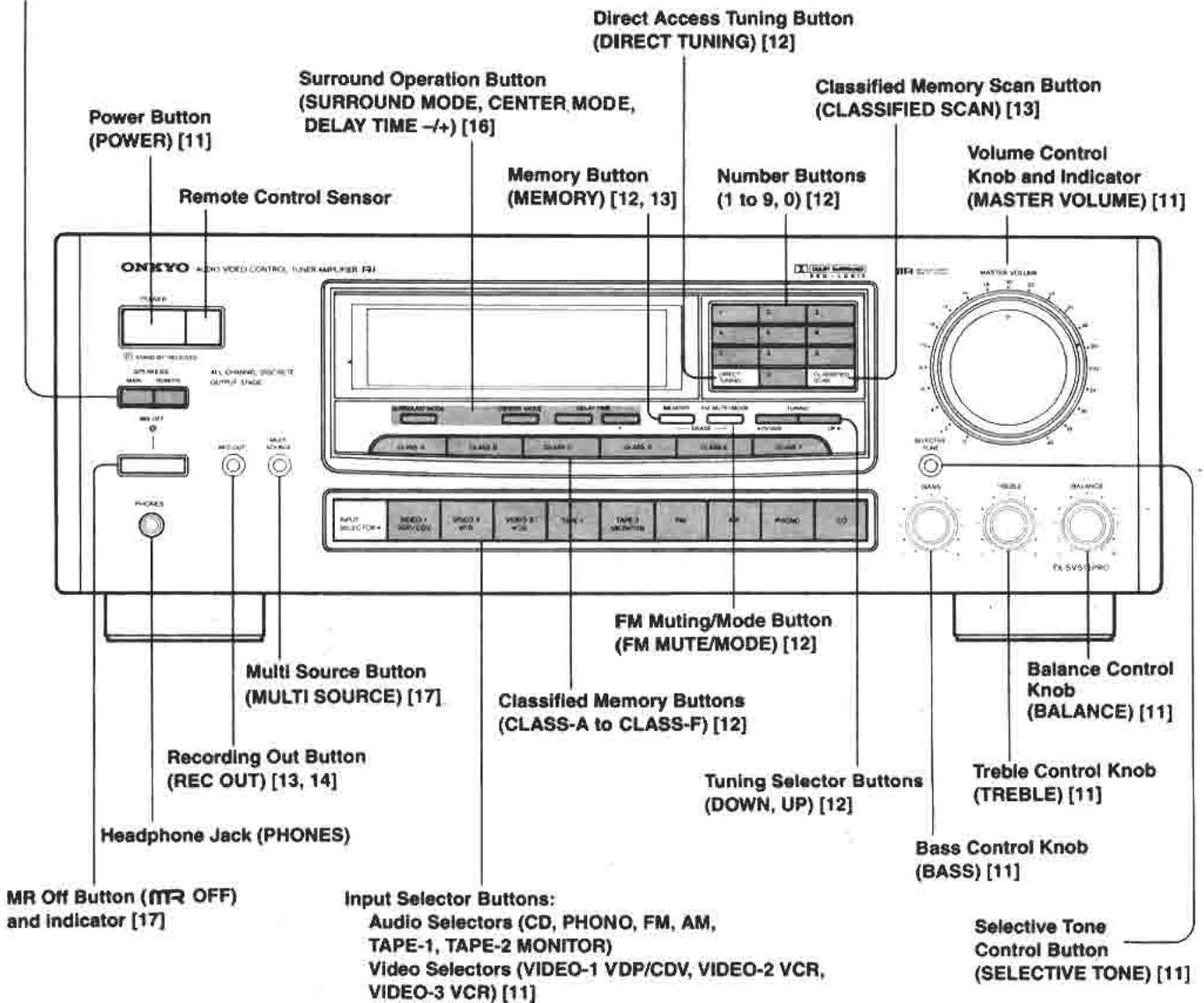

Display and indicators

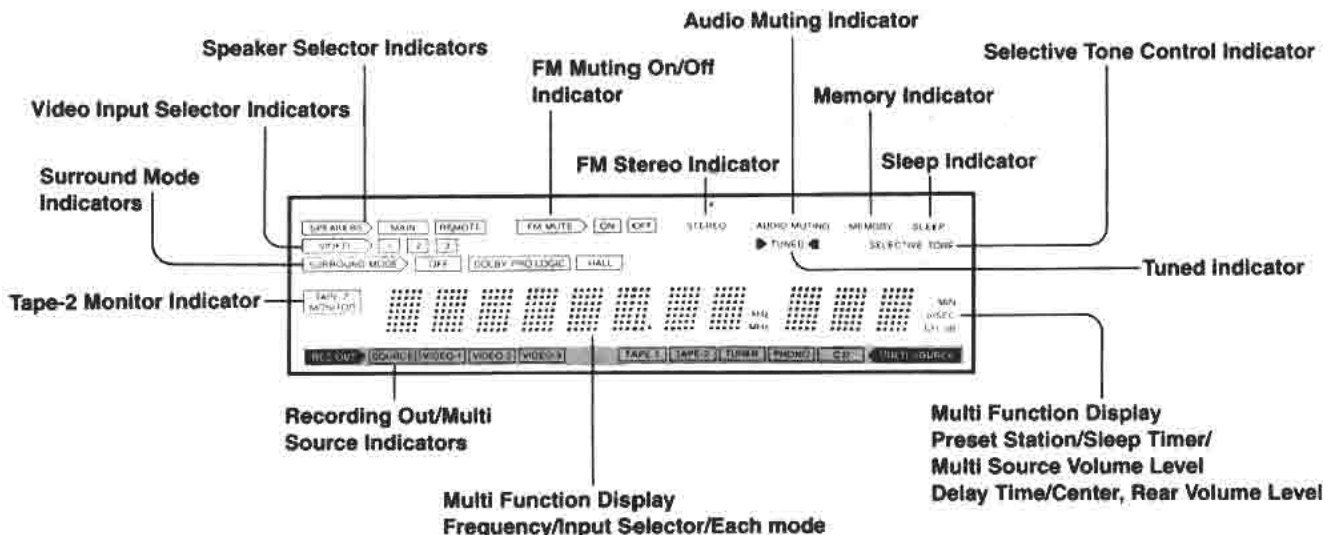

Remote control transmitter RC-252S

Power Button (POWER)

Input Selector Buttons (CD, PHONO, TUNER, VIDEO-1, VIDEO-2, VIDEO-3, TAPE-1, TAPE-2)

- When the TUNER button is pressed, the station which was received previously is recalled. Selection of AM or FM should be done on the main unit.

CD Operation Buttons (CD)

These buttons are used to operate an ONKYO CD player with the **RI** mark.

- : Press this button to play the CD player.
- : Press this button to pause the CD play back. To resume disc play, press the PLAY button.
- DISC : Press to use for sequential selection of discs in the order they were loaded on the CD changer.
- : Press this button to stop the CD player.
- : Press this button to go back to the beginning of the current track and again to skip back to the previous track.
- : Press this button to skip to the next track.

Test Tone Button (TEST)

This operates when Dolby Pro Logic Surround mode has been selected as the SURROUND MODE. Pink noise is produced in order to adjust the volume levels used by the Front, Center, and Rear speakers. Please follow the procedure described above to do this matching. Press the TEST button again after finishing adjustment.

Surround Mode Button (SURROUND MODE)

Delay Time Button (DELAY TIME)

Center Level Up/Down Buttons (CENTER LEVEL UP/DOWN) Rear Level Up/Down Buttons (REAR LEVEL UP/DOWN)

These buttons are used to adjust the volume in the Surround mode. When one of the buttons is pressed in the Surround mode, the display shows the level for two seconds. For the Surround mode, the indication for the center or rear ranges from the minimum of (-∞ dB), -60, -40 ... 0, +1, ... to the maximum of (+12 dB). In the DOLBY PRO LOGIC and HALL modes, different values can be stored.

Sleep button (SLEEP) (Remote control transmitter only)

Press to set the power off timer. The sleep timer is a function which button off the power to the system from the time it is set. When this button is pressed, "90 MIN" is displayed for 5 seconds, and the power goes off 90 minutes later. Each time the button is pressed during 5 seconds, the timer setting changes, by 10 minute intervals, such as 80, 70, 60 ... While the sleep timer is operating, the **SLEEP** indicator is lit. If the sleep button is pressed during this time, the amount of time remaining on the sleep timer is displayed, and if the button is pressed during that display, 10 minutes will be subtracted from that time. If the button is pressed when the panel display shows 10 minutes or less, the sleep timer is cancelled, and the power is not turned off.

Speaker Selector Buttons (SPEAKERS MAIN/REMOTE)

Multi Source Button (MULTI SOURCE)

Multi Source Level Up/Down Buttons (MULTI SOURCE UP/DOWN)

These buttons can be used to adjust the level of the speakers connected to the "REMOTE" speaker terminals (perhaps in another room) when the MULTI SOURCE mode is selected (the **MULTI SOURCE** indicator is lit). When one of the buttons is pressed in the Multi Source mode the display shows the level for two seconds. The indication for the Sub Room output level ranges from the minimum of (-∞ dB), -78, -77 ... -1, to the maximum of (0 dB). Indications include **MULTI** for multi source level. These level settings can be memorized.

Tuner Operation Buttons (TUNER)

CLASS: Class selector button
PRESET UP/DOWN: Preset memory DOWN/UP buttons

Tape Operation Buttons (DECK-A, DECK-B)

These buttons control ONKYO double cassette tape decks that can be remote controlled. Use the DECK-B buttons to control single cassette tape decks with the **RI** mark.

- : When this is pressed, the recording stand-by mode is entered.
- : The tape plays, moving from right to left, or, in the recording stand-by mode, recording begins.
- : Interrupts all operations.
- : The tape plays, moving from left to right, or, in the recording stand-by mode, recording begins.
- : Fast forward from right to left.
- : Fast forward from left to right.

Audio Muting Button (MUTING)

This button temporarily switches off the sound from the speaker or headphone. Pressing this button will operate the TX-SV515PRO audio muting circuit. The audio muting indicator "MUTING" will flash. Pressing the button again or using the POWER button on the remote control transmitter to turn the power on will turn off the audio muting.

- Pressing this button does not mute the sound of the multi source. Press the SPEAKERS REMOTE button to mute the sound of the multi source.

Volume Buttons (VOLUME UP/DOWN)

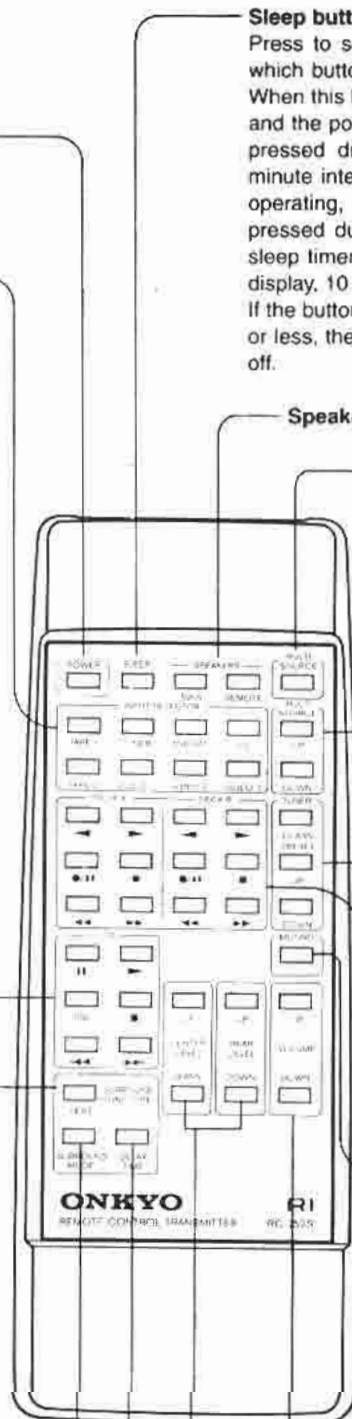

Operations

To listen to your favorite Source

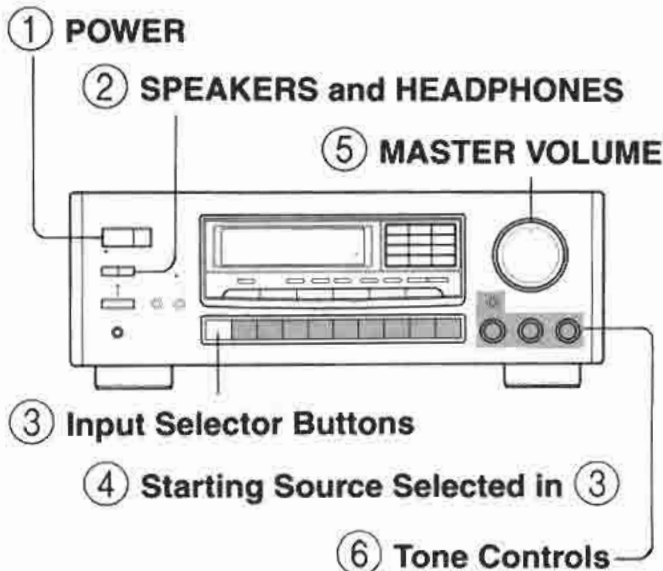

- 1 Press the POWER button to turn on the power.
- 2 Press the MAIN button of the speaker selector buttons. The **MAIN** indicator will be lit. When using headphones, use the jack located under the MR OFF button. Stereo headphones with a standard binaural plug can be connected here. (Sound from the front MAIN speakers is output.) The sound from the headphones in the Surround Mode may be different from that which is obtained from speakers. The sound in the headphones may seem relatively far-away.
- 3 Press one of the desired Input Selector button (CD, PHONO, FM, AM, TAPE-1, TAPE-2 MONITOR, VIDEO-1, 2, 3). Make sure that the connections between the input sources are correct.

- 4 Start play of the selected input source.
 - Follow the operating instructions of that unit.
 - If FM or AM is selected, please refer to the section "Tuner Reception".
- 5 Adjust the MASTER VOLUME Control knob to the appropriate level.
- 6 Adjust the Tone Controls to obtain the desired tone setting.

NOTE:

After selecting VIDEO-1 or VIDEO-2, or VIDEO-3 you can display the images of the selected video source while listening to the sound of another source. (CD, TUNER, PHONO, TAPE-1 or 2) In such case, the setting of the video selector button is indicated by the lit video input selector indicator.

Memory Preservation

This unit does not require memory preservation batteries. A built-in memory power back-up system preserves the contents of the memory during power failures and even when the unit is unplugged. The unit must be plugged in in order to charge the back-up system.

The memory preservation period after the unit has been unplugged varies depending on climate and placement of the unit. On the average, memory contents are protected over a period of a few weeks after the last time the unit has been unplugged. This period is shorter when the unit is exposed to a highly humid climate.

Explanation of the buttons

■ Power button (POWER) and Stand-by/Received indicator

The Stand-by/Received indicator comes on when the AC power cord for this unit has been inserted in an outlet. This indicates that the TX-SV515PRO is standing by for operation. Pressing the POWER button or remote control POWER button, the main unit will come on, and power will be supplied from the AC outlet to the rear panel. This indicator then goes off. The indicator also lights when a signal is received from the remote control unit.

■ Speaker Selector buttons (SPEAKERS MAIN/REMOTE) and indicators

You can operate the SPEAKER SELECTOR from the front panel or with the remote control. When the MAIN and/or REMOTE is ON, the MAIN, REMOTE of the SPEAKER indicator will be lit.

- MAIN speakers button: The front speakers connected to the "MAIN" speaker terminals and the speakers connected to the "CENTER", and "REAR" speaker terminals can all be switched on or off at the same time.
- REMOTE speakers button: The source you selected using the MULTI SOURCE will be output from the REMOTE speakers. When you select the MULTI SOURCE mode, the **MULTI SOURCE** indicator will be lit, then you can switch the speakers connected to the "REMOTE" speaker terminals on or off. However, they cannot be turned on in a mode other than the Multi Source mode. When the REC OUT mode is selected, or during surround playback, these speakers will be automatically switched off.

■ Master Volume Control Knob (MASTER VOLUME)

Use the MASTER VOLUME control knob to adjust the volume of the front main, center and rear (surround) speakers, at the same time. Turn clockwise to increase the volume level. The volume can be adjusted manually and by the remote control transmitter's VOLUME UP/DOWN buttons. The MASTER VOLUME control knob rotates when the volume is adjusted by remote control.

When you adjust the volume with the remote control check the level by looking at the indicator on the knob as it rotates. For fine adjustment of center and rear speaker volume in comparison to front speaker volume, use the remote control transmitters CENTER LEVEL UP/DOWN or REAR LEVEL UP/DOWN buttons. You can adjust the level of the REMOTE speakers by using the only UP/DOWN buttons of the MULTI SOURCE LEVEL on the remote control.

Tone and Balance Controls.

■ Bass Control Knob (BASS)

Adjust to strengthen or weaken bass response. (Not effective for the center, rear speakers and multi source signal.)

■ Treble Control Knob (TREBLE)

Adjust to strengthen or weaken treble response. (Not effective for the center, rear speakers and multi source signal.)

- TREBLE and BASS are effective for the L and R of the front speakers. The best effect from DOLBY PRO LOGIC SURROUND can be obtained when equal settings are used for the sound from the L/R front speakers and the sound from the center speaker for the middle and treble ranges.

■ Balance Control Knob (BALANCE)

Use the Balance Control Knob (BALANCE) to adjust the relative volume levels of the left and right of MAIN speaker systems. This adjusts the relative volume level of the front MAIN speaker systems.

■ Selective Tone Control button (SELECTIVE TONE) and indicator

Switching on this button lights up the indicator and creates a clear reproduction quality of the ultra low frequencies and high frequencies. (Not effective for the rear speakers and multi source signal.)

Tuner Reception

Press the FM or AM Input Selector button and make sure that the TAPE-2 MONITOR indicator is off and audio muting is off.

■ Tuning with the TUNING buttons

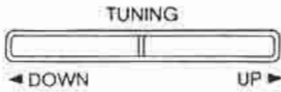

To tune in an FM or AM station not stored in the memory, press one of the Tuning selector buttons. If you press UP, the frequency is increased. Pressing DOWN decreases. Note that the frequency is changed in 50kHz steps in FM and 10(9)kHz steps in AM when the Tuning selector button is pressed in single steps. If this button is pressed continuously for more than 0.5 seconds, the auto tuning mode is entered, and frequencies are scanned automatically. When a broadcast signal is received, scanning stops and that frequency is displayed. If a different frequency is desired, press the button once again.

- Scanning will not stop for broadcasts weak enough to be suppressed by the muting circuit. To receive a weak FM broadcast, set the MUTE/MODE button to the OFF position and select the frequency of the desired broadcast station.

■ Receiving a station by inputting the frequency for the station directly (Direct Tuning)

If the frequency for the desired station is known, input the frequency number directly.

③ Number Buttons

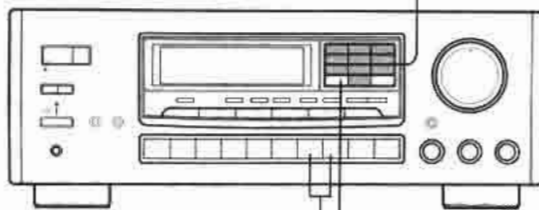

① FM, AM

② DIRECT TUNING

- ① Press the AM or FM button of the Input selector buttons.
- ② Press the DIRECT TUNING button.
 - "-" will flash for 16 seconds in the Frequency display.
- ③ Input the desired frequency number by using the Number buttons while the cursors are flashing. For instance, if you wish to receive the station of 88.10MHz, press the Number buttons, 8, 8, 1 and 0.
 - When receiving AM broadcast with a 9kHz step, use the same procedure as described in step ③ above. With 10kHz steps, inputting a number to the 10kHz digit will set the 1kHz digit automatically to 0.
 - If the desired frequency set in this operation does not exist, the frequency which is the nearest and lower than the desired frequency will be received. If the frequency set is not in the receive frequency range, the frequency flashes for two seconds and then the previous frequency will be displayed.
 - If a wrong frequency has been set, press the DIRECT TUNING button and start again.

■ How to use the FM Muting/Mode button (MUTE/MODE)

In the Muting ON (STEREO) setting, FM stereo reception is possible and the muting circuit suppresses interstation noise and weak FM stations. In the OFF (MONO) setting, interstation noise will be heard and even weak FM stations can be received. (Muting/Mode operation is effective for only FM reception.)



- The Stereo indicator will light up if the broadcast is being received in stereo. The Stereo indicator will not light up if the broadcast is monaural or too weak to be received in Stereo.

Classified Memory Function

The memory can be divided (classified) for different users or programs of stations.

NOTE:

There are times when frequencies are left in the machine's memory from the final testing done prior to shipment. If this is the case with your TX-SV515PRO, cancel unnecessary preset stations according to "How to cancel memorized stations" and memorize desired frequencies.

■ How to classify stations

With this model, six classes (CLASS A to F) are available and stations can be memorized in any class. A total of 40 stations can be memorized in classes from A to F. Although the same station can be memorized in different classes, the memory number for the station will differ depending on the order in which the station is memorized in the classes.

- ① Tune in the desired station (see section on "Tuner Reception").
- ② Press the MEMORY button.
 - The MEMORY indicator will flash for 8 seconds.

- ③ Press the desired Classified Memory button (one of buttons A to F).
 - The station is memorized in the selected class with the memory number which is the smallest of the unoccupied numbers in the class.

By repeating the operations above, up to 40 stations can be memorized. If an attempt is made to memorize 41 stations or more, "FULL" will be displayed indicating that no more stations can be memorized.

■ How to cancel memorized stations

Retrieve the class number you want to cancel (see "How to retrieve memorized stations") and then press the MUTE/MODE button while holding down the MEMORY button. Another station can be memorized with the memory number which has been cancelled.



■ How to retrieve memorized stations

- ① Press the Classified Memory button for the desired class. If remote control is used, the class next to the present one is retrieved when the CLASS button is pressed.
 - The memory number (station) which was being received before the class is retrieved will be received.
- ② There are several methods to proceed after the above operations are carried out. Use any of the following methods.
 - a. Pressing the same Classified Memory button again permits the next preset memory number (station) to be received.
 - b. Input the memory number you wish to receive by using the Number buttons.
 - If the memory number consists of 2 digits, input two numbers, immediately one after the other. For instance, when inputting "15", "15" will not be registered if you wait more than one second before inputting "5", resulting in only "1" being registered.
 - If a number other than a number from 1 to 40, or a number which has not been memorized is input, the number flashes for 2 seconds and then the number which was displayed before will be displayed.
 - If a number between 1 and 4 is pressed, the display and station are changed 1 second later.

- c. Press the CLASSIFIED SCAN button
 - Stations memorized in the present class will be scanned in a order and the corresponding memory number will flash in the Preset station display at each scan. After the last memory number of the class is reached, scanning starts again from the first memory number of the class. Pressing the CLASSIFIED SCAN button again stops scanning.
- d. When the PRESET UP or DOWN button of the remote controller is pressed, the memory number of the class currently being received will be incremented or decremented. Keeping pressing the button increments or decrements continuously. After the maximum or minimum number is reached, the next class or one before the present class will be entered.

Tape Recording

With the TX-SV515PRO you can perform recording while listening to the sound of another source through speakers or headphones. Make all connections between the tape deck and the unit as shown in the System Connections diagram.

- When recording a tape while the multiple room remote control is connected, turn on **MTR OFF** (the **MTR OFF** indicator will light) to disable remote control operation from other rooms.

■ Recording and dubbing to a tape deck connected to TAPE-1

(When recording the source you are listening to)

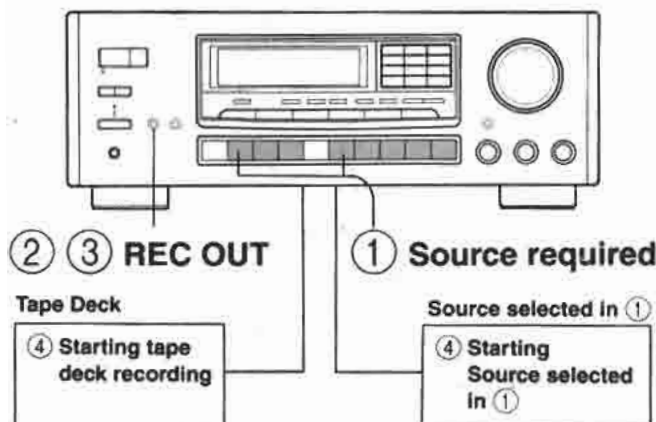

- ① Press the input selector button to select the source to be recorded. (Other than TAPE-1)
- ② Press the REC OUT button.
 - **REC OUT** on the display flashes for 8 seconds.
- ③ Press the REC OUT button again while the **REC OUT** indicator is flashing.
 - **REC OUT** and **SOURCE** will light, and the indication of the source selected by the input selector button will be marked with a red frame.
- ④ Start the device selected in step ①, while setting the tape deck connected to TAPE-1 to recording mode.
 - Set the proper recording level using the controls on the tape deck used for recording. Never change the positions of any controls (bass, treble, etc.) on this unit during recording and dubbing operations.

NOTES:

- Pressing the input selector button during recording will change the source being recorded.
- When the TAPE-2 MONITOR indicator is on, only TAPE-2 can be recorded and if the input selector is changed, the red frame of TAPE-2 will not change.

(When recording a source different from the one you are listening to)

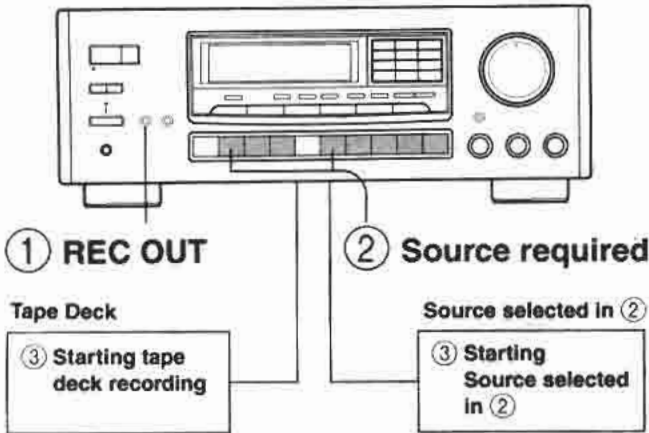

- ① Press the REC OUT button.
 - REC OUT on the display will flash for 8 seconds.
- ② Press the input selector button for the source to be recorded while the REC OUT indicator is flashing. (Other than TAPE-1)
 - REC OUT will light and the indication of the source selected will be marked with a red frame. This source will be output from the REC OUT jacks of TAPE-1, VIDEO-2 or VIDEO-3. The source you are listening to does not change.
- ③ Start the source device selected in step ②, and start recording on the tape deck connected to TAPE-1.

NOTE:

- If FM or AM is selected on the tuner (as described in step ② above) and the input selector is set to something other than TUNER, the tuner's frequency and class displays will be shown for 5 seconds. During this time a tuner preset station can be selected.

■ Recording and dubbing to a tape deck connected to TAPE-2

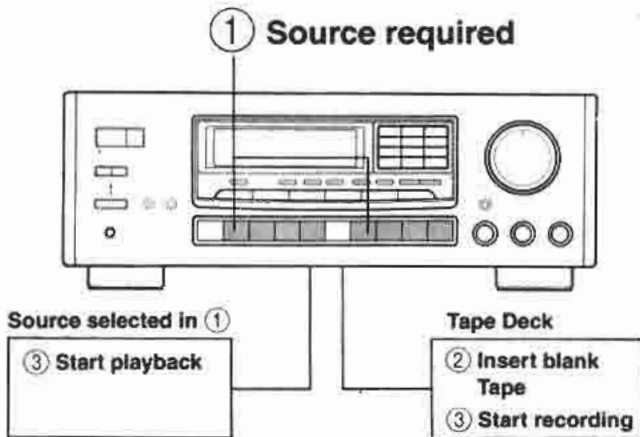

- ① Press the input selector button of the source to be recorded. (Other than TAPE-2)
- ② Put a blank tape in TAPE-2.
- ③ Start playing back the device selected in step ①, and start recording on TAPE-2.
 - When the TAPE-2 MONITOR button is in the OFF position, the source signals can be monitored through the speakers or the headphones. If tape deck 2 has three heads, the just-recorded signals can be monitored (when the TAPE-2 MONITOR button is in the ON position). Refer to the tape deck instruction manuals for more details.
 - Set the recording level using the controls on the tape deck used for recording. Never change the positions of any controls (bass, treble, etc.) on this unit during recording and dubbing operations.

■ Using the Graphic Equalizer

- ① Connect the graphic equalizer to the TAPE-2 jacks on the rear panel.
- ② If a second tape deck is used, connect it to the tape jacks on the graphic equalizer.
- ③ Press the TAPE-2 MONITOR button.
 - Follow the graphic equalizer operating instructions.
 - To record an equalized signal, use tape deck 2 (connected to the equalizer) for recording.

■ VCR recording

Data can be recorded from Video Disc Players, Video camcorders, and Video Cassette Recorders to Video Cassette recorders connected to VIDEO-2, 3.

Connect the VCR to VIDEO-2, and/or VIDEO-3.

(When recording the source being played back)

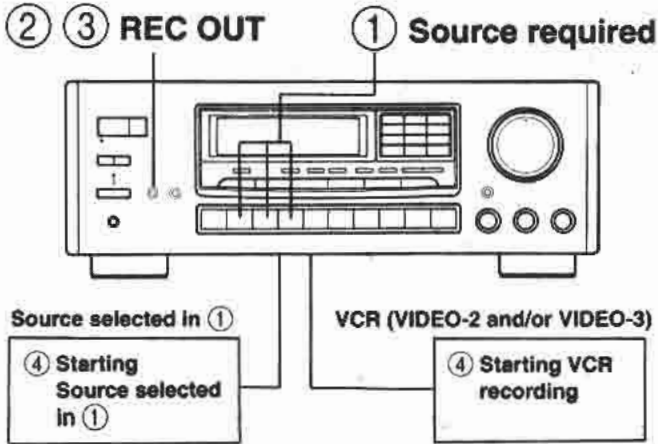

- ① Select the source to be recorded with the input selector button.
- ② Press the REC OUT button.
 - REC OUT on the display will flash for 8 seconds.
- ③ Press the REC OUT button again while the REC OUT is flashing.
 - REC OUT and SOURCE will light and the source selected with the input selector will be marked with a red frame.
- ④ Start the source selected in step ①, and start recording the VCR connected to VIDEO-2 and/or VIDEO-3.

(When recording a source different from the one being played back)

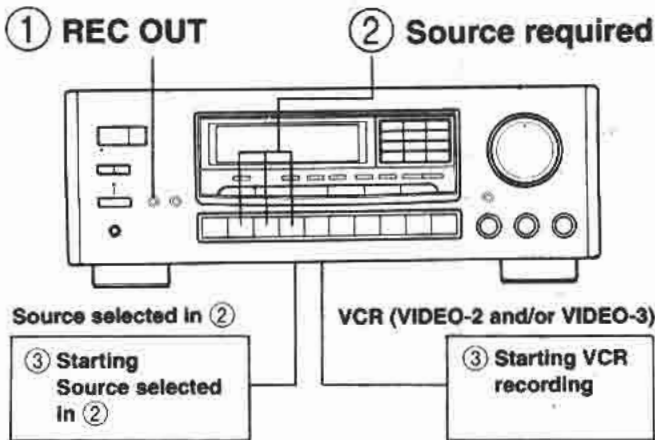

- ① Press REC OUT button.
 - REC OUT on the display will flash for 8 seconds.
- ② Press the input selector button of the source to be recorded while the REC OUT indicator is flashing.
 - REC OUT will light, and the source selected will be marked with a red frame.
- ③ Start the source selected in step ②, and start recording the VCR connected to VIDEO-2 and/or VIDEO-3.

■ Mixing video and audio for VCR recording

- ① Press the Input Selector button to select the video equipment (VIDEO-1, 2, 3) to be used when playing the video. Press the REC/PAUSE button on the VCR (VIDEO-2 or 3) that will be doing the recording.
- ② Press the REC OUT button and Input Selector button (CD, PHONO, FM, AM, TAPE-1, TAPE-2) to select the audio source.
 - The picture will be left as is. Only the audio will be changed.
- ③ Start operation of the equipment.
- ④ The picture will be recorded from the video source, and the sound from the audio source.

Use of Surround mode

■ Surround Mode button (SURROUND MODE) and indicators

Use this button in conjunction with the sound source being reproduced. This will rotate one step at a time through the following pattern each time this button is pressed:

→ DOLBY PRO LOGIC → HALL → OFF (Bypass) →

DOLBY

PRO LOGIC : When the sound source features the DOLBY SURROUND trademark.

HALL : Create a concert-hall effect.

OFF

(Bypass) : When you are not using surround sound. When this is pressed, no sound is produced from the center and rear (surround) speakers.

These modes can be changed with the remote control transmitter by using the SURROUND MODE button.

- When you press and hold down the SURROUND MODE button, the name of each mode will be shown on the display for 2 seconds in turn.
- In the SURROUND MODE each selected source along with the input selector source is automatically stored, and consequently recalled when that input selector source is selected.
- When the SURROUND MODE is set to HALL, the center speaker does not produce sounds.

■ Delay Time button (DELAY TIME -/+) and indicator

You can change the delay time for the sound from the rear (surround) speakers. Pressing this button changes the delay time every 5 msec during a period of 15 to 30 msec in Dolby Pro Logic, and Hall surround.

- When you press and hold down the DELAY TIME button, "DELAY" and the delay time will be shown for 3 seconds on the display.

Dolby Surround delay time is specified at 20msec. It is recommended that initial Dolby Surround delay be set at 20msec, and adjustment to either 15 or 30 is possible via the control. By adjusting the delay time, and carefully adjusting Master Volume Level, Center Volume Level and Rear Volume Level, the apparent acoustic size of your listening room can be enlarged or reduced. Adjustable delay time allows you to tailor the acoustic size of your listening environment to match the sonic characteristics of the audio program. Use a longer delay for larger acoustic spaces, such as concert halls, cathedrals, etc. Use a shorter delay to simulate the size of a small club or cabaret. Respective delay times can be memorized for DOLBY PRO LOGIC and HALL. This operation can also be performed using the delay time button of the remote control transmitter.

NOTE:

If you are in surround mode and change the delay time, but the rear (surround) speakers are not connected, nothing will happen. However, even under these conditions, each time the delay time button and surround mode button are pressed, front speaker muting will occur and sound will disappear momentarily. This is not a malfunction.

■ Center Mode button and indicator (CENTER MODE)

Use this button setting according to the size of the center speaker for the Dolby Pro Logic Surround.

NORMAL : Use this setting when a small enclosure center speaker is utilized.

WIDE BAND : Use this setting when a speaker similar to the left and right stereo speakers is utilized.

PHANTOM : When a center speaker is not present.

- When you press and hold down the CENTER MODE button, the name of each mode will be shown on the display for 3 seconds in turn.

■ Adjusting the Dolby Pro Logic Surround Level

All the operations can be controlled by the remote control transmitter. Functions No. ④ to ⑥ are operated only by the remote control transmitter.

- ① Select a source encoded with Dolby Surround.
- ② Use the SURROUND MODE button to select Dolby Surround mode.
- ③ Next, use the MASTER VOLUME to set the volume to the desired listening position.
- ④ Press the TEST button on the remote control transmitter.
 - "TEST" will appear on the display, and pink noise will be output for 1.5 seconds from each of the Left, Center, Right, and Rear (in that order) speakers. When the center mode is PHANTOM, this will be output in the following order: Left, Left + Right, Right, and Rear.
- ⑤ Use the remote control CENTER LEVEL UP/DOWN button to adjust the volume of the center speaker, and REAR LEVEL UP/DOWN button to adjust the volume of the rear speakers. Set the front, rear, and center speakers to the same volume.
- ⑥ Press the TEST button to cancel the pink noise.

Listening to devices connected to the TX-SV515PRO in another room

- TX-SV515PRO allows you to listen to the desired performance in another room (sub room) while listening to the playback of a device located in the main room. To do this, connect the speakers in another room to the FRONT SPEAKERS REMOTE terminals on the TX-SV515PRO.
- Remote control from another room can be done by employing the ONKYO multiple room remote system (MR). Refer to the connections for multiple room remote control. Be sure to operate the remote control unit directing to the remote sensor unit HR-10.
- The following steps (except step ①) can be performed using the remote control unit. It is recommended that the adjustments described below be done in the main room in advance, since it is not possible to operate the remote control unit in another room while watching the display of the TX-SV515PRO.

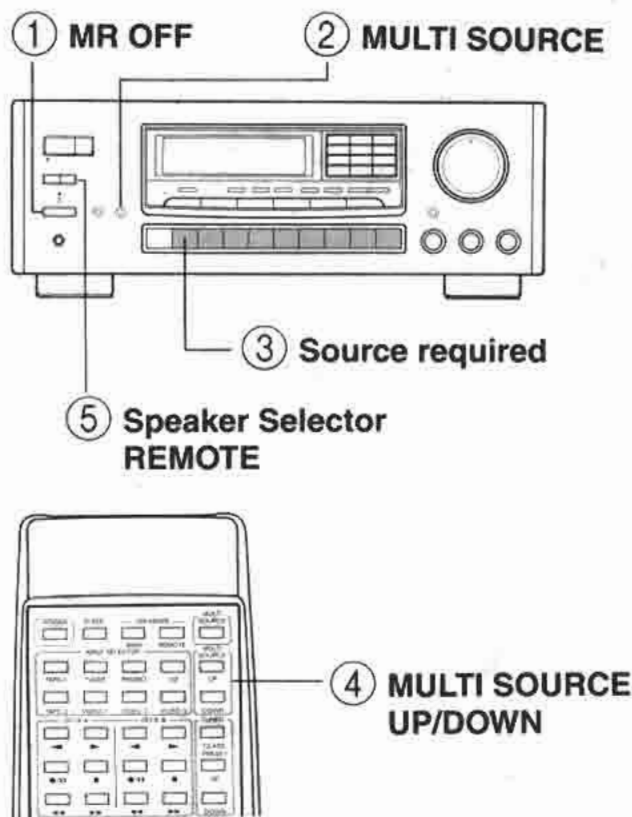

NOTES:

- The surround mode will be turned OFF (Bypass) when MULTI SOURCE is used.
- The source indicated by the input selector will be output from the TAPE-1 and 2, and VIDEO-2 and 3 REC OUT terminals.
- Press the REC OUT button to change the MULTI SOURCE mode to the Surround mode or REC OUT selector modes.

Make sure that recording is not being carried out before setting the TX-SV515PRO.

- ① Turn the MR OFF button OFF (MR indicator is turned off.)
 - ② Press the MULTI SOURCE button.
 - REC OUT indicator will be turned off and the MULTI SOURCE indicator will flash for 8 seconds.
 - ③ While this is flashing, use the input selector button to select the desired source.
 - MULTI SOURCE will light and the selected source will be marked with a red frame.
 - If tuner is selected with MULTI SOURCE and the input selector is set to something other than TUNER, the tuner's frequency and class displays will be shown for 5 seconds. During this time a tuner preset station can be selected.
 - ④ Adjust the level using the MULTI SOURCE UP/DOWN buttons of the remote control transmitter.
 - MULTI and the level will be indicated on the display. It is recommended that the level be set lower in advance in the main room (-78 to -76dB).
 - ⑤ Press the REMOTE button of the SPEAKERS to illuminate the REMOTE indicator.
 - Press the MAIN button to turn off the MAIN indicator if you are not listening the sound in the main room.
- When changing the source, be sure to press the MULTI SOURCE button before pressing the input selector button. Pressing the input selector button without first pressing the MULTI SOURCE button will change the source in the main room.

MR Off button (MR OFF) and indicator

Use this button for tape recording or for the surround sound modes. It is used to disable control of the ONKYO MR system via the remote control unit in another room. Pressing this button will illuminate the indicator, and control from another room will be disabled. Pressing the button again will turn the indicator off, and control from another room will be enabled.

NOTES:

- If the multi source is selected, the MR OFF automatically turned OFF.
- If the multi source is selected for REC OUT, and the SURROUND MODE key is selected, the MR OFF automatically turned OFF.

- You can use the remote control transmitter supplied with this Tuner Amplifier to operate the source devices selected for the multi source if they are an ONKYO CD or cassette deck bearing the RI mark.
- There is a remote control unit RC-MR1H for the sub room, which is sold separately.
- Installation of the remote sensor unit HR-10 and the remote emitter unit HE-50(AC) is required to control non-ONKYO devices from another room (sub room). Operate the remote control unit included with the device by directing the control unit toward the HR-10 installed in another room (sub room).

- If a problem occurs, use the TX-SV515PRO's front panel controls to verify that the problem is with the remote controller. If there is no problem when operating the TX-SV515PRO directly, check the batteries in the remote controller first before assuming that there is a controller malfunction.

NOTES:

- The source may be changed or recording being done on the TX-SV515PRO may be interrupted when operations are done in the another room. Press the MR Off button to disable the control from another room. (The MR indicator will be illuminated.)
- Some non-ONKYO remote control transmitters cannot be used.

Troubleshooting guide

NOTE:

If a problem occurs, first operate the unit using the front panel controls to confirm that it is not due to a malfunction (or worn out batteries) of the remote control transmitter.

Trouble	Cause	Remedy
No power.	<ul style="list-style-type: none"> ● Power cord is disconnected. ● There is external noise in the computer circuits of the TX-SV515PRO. ● AC fuse blown. 	<ul style="list-style-type: none"> ● Connect power cord. ● Turn the power button off and then on again or remove the AC plug from the outlet and then plug it again. ● Contact your ONKYO service center.
Power but no sound.	<ul style="list-style-type: none"> ● Tape monitor switch on. ● Audio muting switch on. ● Bad connections. ● Amplifier protection circuitry has been activated. 	<ul style="list-style-type: none"> ● Switch to off. ● Switch to off by remote control transmitter ● Check connections, speaker leads, etc. ● Contact your ONKYO service center.
Hum, low-frequency noise.	<ul style="list-style-type: none"> ● Poor or no input ground. ● Poor or no phono motor ground. ● The placement of the audio connection cable on the rear panel is not correct. 	<ul style="list-style-type: none"> ● Check outer conductor of input plugs. ● Check for proper ground connection. ● Adjust the placement of the cables to reduce hum.
Howling when the volume is turned up.	<ul style="list-style-type: none"> ● Turntable and speakers are too close together. 	<ul style="list-style-type: none"> ● Move them farther apart.
Rough or scratchy sound. High range is not clear.	<ul style="list-style-type: none"> ● Stylus of pick-up is worn. ● Stylus tip is dirty. ● Treble control too high. 	<ul style="list-style-type: none"> ● Replace. ● Clean. ● Turn treble control down.
AM stations cannot be received.	<ul style="list-style-type: none"> ● AM loop antenna is not attached. 	<ul style="list-style-type: none"> ● Connect the included AM loop antenna to the AM antenna terminals.
Buzzing noise on AM (particularly conspicuous at night or with weak stations).	<ul style="list-style-type: none"> ● Noise from electrical apparatus such as fluorescent lamp. 	<ul style="list-style-type: none"> ● Move AM loop antenna to different position. ● Set up outdoor AM antenna.
High-pitched noise or buzzing noise on TV.	<ul style="list-style-type: none"> ● Noise from TV set. 	<ul style="list-style-type: none"> ● Place the AM loop antenna as far as possible from the TV. ● Move unit away from TV set.
Crackling noise on AM, FM.	<ul style="list-style-type: none"> ● Noise caused by turning fluorescent lamp on and off. ● Noise from automobile ignition. 	<ul style="list-style-type: none"> ● Move antenna as far as possible from the fluorescent lamp. ● Install an FM outdoor antenna as far as possible from the road. ● Change the position or direction of the outdoor antenna.
FM tuned and stereo indicators light but sound is distorted and stereo separation is bad.	<ul style="list-style-type: none"> ● Station is too strong. ● Multiple reflection of the radio waves because of tall buildings or mountains. 	<ul style="list-style-type: none"> ● Change to T-shaped antenna. ● Use antenna which has better directivity and select a point where the distortion is least.
FM tuned indicator and stereo indicator flicker and hiss is heard on FM.	<ul style="list-style-type: none"> ● Station is too weak. ● Stereo FM broadcasts cover only about half the distance of an ordinary broadcast. 	<ul style="list-style-type: none"> ● Install an outdoor FM antenna. ● Change the position or direction of the outdoor antenna.
No station is recalled when a preset key is pressed.	<ul style="list-style-type: none"> ● The power cord has been unplugged for a long time. 	<ul style="list-style-type: none"> ● The memory contents are lost. Store all stations again.
The multiple room remote system does not operate.	<ul style="list-style-type: none"> ● Connection is wrong. ● The MR OFF button on the TX-SV515PRO is engaged. (The MR OFF indicator will light.) 	<ul style="list-style-type: none"> ● Check the connection again. ● Press the MR OFF button. (The MR OFF indicator will be turned OFF.)
Front panel controls function but remote control transmitter does not.	<ul style="list-style-type: none"> ● No batteries in remote control transmitter. ● Batteries have worn out. 	<ul style="list-style-type: none"> ● Insert batteries. ● Replace batteries.
Also refer to the respective instruction manuals of the video disc player, video cassette recorder, TV monitor, etc., being used.		

The tuning steps by which the tuned frequency changes on each band have been set at the factory to the proper value for the country where each unit is to be sold. If you use the unit in a country where a different tuning step is required or if the broadcast frequencies in your country change so that you can not tune in radio stations precisely, contact your authorized ONKYO Service Center.

Specifications

AMPLIFIER SECTION

Power Output:	Stereo mode Front L/R channels 80 watts per channel min. RMS. at 8 ohms, both channels driven, from 20 Hz to 20,000 Hz, with no more than 0.08% total harmonic distortion.
	Surround mode and Multi source mode Front L/R and center channels 55 watts per channel min. RMS. at 8 ohms, 1,000 Hz with no more than 0.08% total harmonic distortion.
	Rear or Remote channels 20 watts per channel min. RMS. at 8 ohms 1,000 Hz with no more than 0.8% total harmonic distortion.
Total Harmonic Distortion:	0.08% at rated power (FRONT)
IM Distortion:	0.08% at rated power (FRONT)
Damping Factor:	60 at 8 ohms (FRONT)
Sensitivity and Impedance:	Phono: 2.5 mV/50 kohms CD/Tape Play: 150 mV/50 kohms Tape Rec: 150 mV/2.2 kohms
Phono Overload:	120 mV RMS. at 1,000 Hz, 0.5% THD.
Frequency Response:	20 to 30,000 Hz, +/-1 dB
RIAA Deviation:	20 to 20,000 Hz, +/-0.8 dB
Tone Control:	BASS: +/-10 dB at 100 Hz TREBLE: +/-10 dB at 10,000 Hz
Signal to Noise Ratio:	PHONO: 80 dB (IHF A, 5 mV input) CD/TAPE: 100 dB (IHF A)
Muting:	-∞ dB

VIDEO SECTION

Signal sensitivity and impedance
VDP/VCR input, output: 1 Vp-p, 75 ohms

TUNER SECTION

FM:

Tuning Range:	87.5 — 108.0 MHz (50 kHz steps)
Usable Sensitivity:	Mono: 11.2 dBf, 2.0 μV Stereo: 17.2 dBf, 4.0 μV
50dB Quieting Sensitivity:	Mono: 17.2 dBf, 4.0 μV Stereo: 37.2 dBf, 40 μV
Capture Ratio:	1.5 dB
Image Rejection Ratio:	40 dB
IF Rejection Ratio:	90 dB
Signal-to-Noise Ratio:	Mono: 73 dB Stereo: 67 dB
Alternate Channel Attenuation:	55 dB
AM Suppression Ratio:	50 dB
Total Harmonic Distortion:	Mono: 0.15% Stereo: 0.25%
Frequency Response:	30 — 15,000 Hz +/-1.5 dB
Stereo Separation:	45 dB at 1 kHz/30 dB at 100 — 10,000 Hz
Muting Level:	17.2 dBf, 4.0 μV

GENERAL

Power Supply:	USA & Canadian models AC120 V, 60 Hz Worldwide models 120 and 220 V switchable, 50/60 Hz
Dimensions (W x H x D):	455 x 170 x 388 mm 17-15/16" x 6-11/16" x 15-5/16"
Weight:	13.5 kg (29.8 lbs)

AM:

Tuning Range:	USA & Canadian models 530 — 1710 kHz (10 kHz steps) Worldwide models 531 — 1602 kHz (9 kHz steps)
Usable Sensitivity:	30 μV
Image Rejection Ratio:	40 dB
IF Rejection Ratio:	40 dB
Signal-to-Noise Ratio:	40 dB
Total Harmonic Distortion:	0.7%

Specifications and features are subject to change without notice.

This device employs a microcomputer to perform various functions and operations. If interference generated by an external power supply, radio waves, or other electrical source results in an accident which causes the specified operations and functions to operate abnormally. To perform a reset, please follow the procedure below.

1. Press and hold down the CD button, then press the POWER button.
2. "Test-" is displayed on the display for approximately 5 seconds.
3. While "Test-" is displayed, unplug the TX-SV515PROs power cord from its AC outlet, then "Test-" will disappear.
4. Preset memory and parameters stored in memory, such as surround are initialized and will return to the factory settings.

ONKYO CORPORATION

International Division: 2-1, Nisshin-cho, Neyagawa-shi, OSAKA 572, JAPAN
Tel: 0720-31-8133 Fax: 0720-34-1340

ONKYO U.S.A CORPORATION

200 Williams Drive, Ramsey, N.J. 07446, U.S.A.
Tel: 201-825-7950 Fax: 201-825-8150

Specifications

AMPLIFIER SECTION

Power Output:	Stereo mode Front L/R channels 80 watts per channel min. RMS. at 8 ohms, both channels driven, from 20 Hz to 20,000 Hz, with no more than 0.08% total harmonic distortion.
	Surround mode and Multi source mode Front L/R and center channels 55 watts per channel min. RMS. at 8 ohms, 1,000 Hz with no more than 0.08% total harmonic distortion.
	Rear or Remote channels 20 watts per channel min. RMS. at 8 ohms 1,000 Hz with no more than 0.8% total harmonic distortion.
Total Harmonic Distortion:	0.08% at rated power (FRONT)
IM Distortion:	0.08% at rated power (FRONT)
Damping Factor:	60 at 8 ohms (FRONT)
Sensitivity and Impedance:	Phono: 2.5 mV/50 kohms CD/Tape Play: 150 mV/50 kohms Tape Rec: 150 mV/2.2 kohms
Phono Overload:	120 mV RMS. at 1,000 Hz, 0.5% THD.
Frequency Response:	20 to 30,000 Hz, +/-1 dB
RIAA Deviation:	20 to 20,000 Hz, +/-0.8 dB
Tone Control:	BASS: +/-10 dB at 100 Hz TREBLE: +/-10 dB at 10,000 Hz
Signal to Noise Ratio:	PHONO: 80 dB (IHF A, 5 mV input) CD/TAPE: 100 dB (IHF A)
Muting:	-∞ dB

VIDEO SECTION

Signal sensitivity and impedance
VDP/VCR input, output: 1 Vp-p, 75 ohms

TUNER SECTION

FM:

Tuning Range:	87.5 — 108.0 MHz (50 kHz steps)
Usable Sensitivity:	Mono: 11.2 dBf, 2.0 μV Stereo: 17.2 dBf, 4.0 μV
50dB Quieting Sensitivity:	Mono: 17.2 dBf, 4.0 μV Stereo: 37.2 dBf, 40 μV
Capture Ratio:	1.5 dB
Image Rejection Ratio:	40 dB
IF Rejection Ratio:	90 dB
Signal-to-Noise Ratio:	Mono: 73 dB Stereo: 67 dB
Alternate Channel Attenuation:	55 dB
AM Suppression Ratio:	50 dB
Total Harmonic Distortion:	Mono: 0.15% Stereo: 0.25%
Frequency Response:	30 — 15,000 Hz +/-1.5 dB
Stereo Separation:	45 dB at 1 kHz/30 dB at 100 — 10,000 Hz
Muting Level:	17.2 dBf, 4.0 μV

GENERAL

Power Supply:	USA & Canadian models AC120 V, 60 Hz Worldwide models 120 and 220 V switchable, 50/60 Hz
Dimensions (W x H x D):	455 x 170 x 388 mm 17-15/16" x 6-11/16" x 15-5/16"
Weight:	13.5 kg (29.8 lbs)

AM:

Tuning Range:	USA & Canadian models 530 — 1710 kHz (10 kHz steps) Worldwide models 531 — 1602 kHz (9 kHz steps)
Usable Sensitivity:	30 μV
Image Rejection Ratio:	40 dB
IF Rejection Ratio:	40 dB
Signal-to-Noise Ratio:	40 dB
Total Harmonic Distortion:	0.7%

Specifications and features are subject to change without notice.

This device employs a microcomputer to perform various functions and operations. If interference generated by an external power supply, radio waves, or other electrical source results in an accident which causes the specified operations and functions to operate abnormally. To perform a reset, please follow the procedure below.

1. Press and hold down the CD button, then press the POWER button.
2. "Test-" is displayed on the display for approximately 5 seconds.
3. While "Test-" is displayed, unplug the TX-SV515PROs power cord from its AC outlet, then "Test-" will disappear.
4. Preset memory and parameters stored in memory, such as surround are initialized and will return to the factory settings.

ONKYO CORPORATION

International Division: 2-1, Nisshin-cho, Neyagawa-shi, OSAKA 572, JAPAN
Tel: 0720-31-8133 Fax: 0720-34-1340

ONKYO U.S.A CORPORATION

200 Williams Drive, Ramsey, N.J. 07446, U.S.A.
Tel: 201-825-7950 Fax: 201-825-8150