

The National Horizon 10-watt amplifier.

By ROBERT F. SCOTT
TECHNICAL EDITOR

Circuit Features in HI-FI Power AMPLIFIERS

Circuit analysis of the single-ended push-pull amplifier in National's Horizon series

IN the preceding installment (August) we saw how the McIntosh unity-coupled output circuit solves the problem of switching transients and notch distortion caused by high leakage reactance in output transformers in class-AB and -B service. A different solution is offered by Drs. Donald B. Sinclair and Arnold P. G. Peterson. Theirs is the *single-ended push-pull* circuit used in the National Company's Horizon 10 and Horizon 20 amplifiers.

In the conventional push-pull circuit (Fig. 1) the tubes develop a.c. signal voltages that are series-aiding across the load while the plates are paralleled across the d.c. supply. The new single-ended push-pull circuit is the dual or converse of the conventional in that the tubes are in series for d.c. and supply the load in parallel. Thus the optimum load impedance—as in the McIntosh circuit—is only one-quarter of the plate-to-plate load in the usual push-pull connection.

Fig. 2 shows a basic form of the new circuit. The tubes are in series across a d.c. supply with the load connected between a tap on the B supply and the

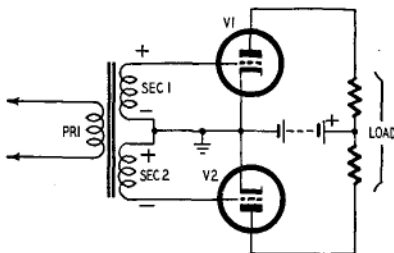

Fig. 1—Conventional push-pull circuit.

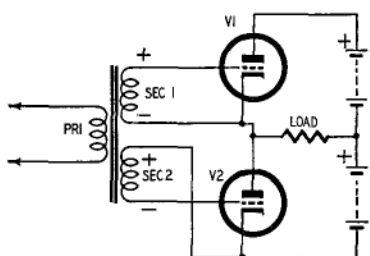

Fig. 2—Single-ended push-pull circuit.

plate-cathode junction. Although the load is in its cathode circuit, we cannot consider V1 as a cathode follower because the signal voltage is applied between the grid and cathode rather than between grid and ground as in a cathode follower. The load also appears in the plate circuit of V2 which, like V1, has its grid driving signal applied between grid and cathode.

The voltages at the ends of the secondary of a transformer are 180° out of phase, so that connections to secondary No. 2 are transposed to show that the grids of V1 and V2 are driven in the same manner as in Fig. 1.

The basic single-ended push-pull amplifier with signal voltages supplied by a phase inverter is shown in Fig. 3. We have retained the dual power supply of Fig. 2. Grid excitation for V1 is developed across R1, the phase inverter plate load resistor and the grid return for V1. By careful selection of operating conditions we can use this direct-coupled circuit with V1 being biased by the drop across R1. Tube V2 is driven by an equal but 180°-out-of-phase signal voltage across R2 in the phase inverter cathode return. Battery BA1 supplies operating bias for V2 because grounding R2 directly would make V2's grid positive with respect to its cathode.

Two of the three d.c. supplies can be eliminated by using the variation in

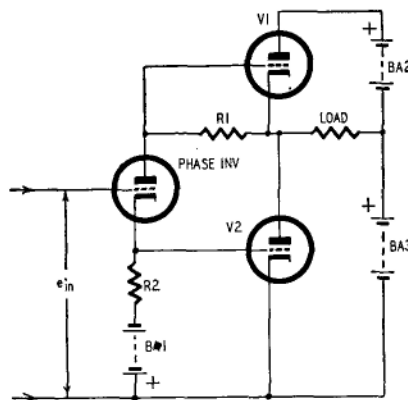

Fig. 3—Phase inverter feeds amplifier.

Fig. 4. Battery BA1 is eliminated by using the drop across R3 as cathode bias for V2. Batteries BA2 and BA3 are replaced by a single supply (BA4) delivering a voltage equal to that of BA2 and BA3 in series. The load is connected between the plate-cathode junction and the junction of two large capacitors (C1 and C2) in series across BA4.

Fig. 5 illustrates another variation of the basic circuit. This is used when one side of the load must be grounded.

Although the optimum load impedance of these circuits is only one-quarter that used in conventional push-pull operation, it is still too high for direct coupling to voice coils in the conventional impedance range. A single 6A7-G used for V1 and V2 has an optimum load impedance of around 280 ohms and it may be used to drive two 500-ohm speakers (Stephens or equivalent) in parallel through a direct connection. However, we must still use an output transformer for matching speakers with voice coil impedances in the range of 4 to 16 ohms.

Fig. 6 is the equivalent circuit of Fig. 4 with pentode output tubes transformer-coupled to the load. The output transformer has a split primary. Screen-to-cathode bypass capacitors C1 and C2 and filter capacitor C3 effectively connect the halves of the primary in parallel for audio signal voltages.

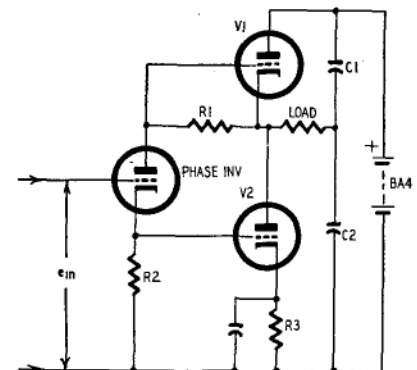

Fig. 4—Amplifier uses single battery.

AUDIO—HIGH FIDELITY

Radio Experimenter, October, 1951, and in the January, 1952, issue of *Proceedings of the IRE*.

Here the plate currents for the phase inverter and V2 and the screen current for V1 flow through L2. The cathode current (sum of plate and screen currents) of V1 flows through L1. This arrangement causes a difference in the direct-current flow in L1 and L2 and results in a d.c. drop across both windings that reduces the supply voltage for V1's screen and the plate of V2. This circuit and current unbalance is minimized by careful design to avoid flux unbalance in the transformer.

Unlike the basic circuits in Figs. 3 to 7, R-C coupling is used between the phase inverter and the grids of V1 and V2 in the Horizon amplifiers. Fixed grid bias is developed by a half-wave selenium rectifier and a simple R-C filter and applied to the output grids.

The plate supply for the phase inverter is taken from the plate-cathode junction of the output tubes. The output signal developed at the plate of V2 is in series with the phase inverter d.c. plate supply and the negative feedback voltage thus developed reduces the distortion and gain in this stage. The loss in phase inverter gain is minimized by returning its cathode load resistor to the bias supply to increase the effective plate voltage.

The voltage amplifier is conventional and uses fixed bias obtained by returning its cathode to a tap on a B plus voltage divider. Distortion in the power amplifier is further reduced by 16 db of negative feedback from the secondary of the output transformer to the voltage amplifier cathode.

Preamplifier—equalizer

The preamplifier and equalizer section has four input channels. One for a radio tuner, one for playing back tape recordings and two for magnetic phonograph cartridges. The 10-mv phono input channel is for low-output cartridges such as the G-E variable-reluctance type; the 30-mv channel is for high-output types such as the Pickering and Audak. The tape input channel may be used for crystal cartridges and other devices delivering 0.5 volt or more.

The function selector switch has five positions. One for tape, one for radio tuner and three to select the phonograph input circuits and to provide equalization for AES, RIAA and foreign recording characteristics.

The bass control provides a boost beginning at 1 kc and rising to a maximum of 15 db at 30 cycles. The treble control provides a boost that begins at around 800 cycles and rises gradually to flatten out for a maximum of 12 db between 10 and 15 kc. Treble attenuation begins at 1,500 cycles, reaches 3 db at 5 kc and is a maximum of 17 db at 20 kc.

The next installment will discuss the circuitry in the output stages of the Circlotron amplifiers developed by Electro-Voice. END

Field-Tested . . . Proven Best!

Good Service Companions

UNITED STATES
ELECTRONIC

REN-O-LYZER

Electronically Analyzes, CORRECTS Picture Tube Trouble in 2 Minutes!

Cleans Picture Tube elements, burns off oxygen, welds open cathodes and filaments . . . automatically and electronically! The TV Serviceman can now RESTORE picture tubes IN THE HOME! Service Charge just \$9.95 to customer—may be sold with minimum guarantee! 7"x9"x4" 6½ lb. steel-cased kit.

UNITED STATES
ELECTRONIC

TUBE-CHECKER

MUTUAL CONDUCTANCE AND EMISSION CHECKER

Accurately checks Picture and Circuit Tubes for filament continuity, emission, gas, shorts and leakage under actual load conditions—in 20 seconds! 7"x9"x4" 7 lb steel-cased kit.

ONLY THE REN-O-LYZER FORECASTS REPAIRABILITY!

Increase your customer-confidence—increase your sales amazingly with these "ON THE JOB" quality-built, electronic companions! You can restore dark, fuzzy pictures to full, bright contrast with the revolutionary REN-O-LYZER! Surveys prove that 90.1% of picture tubes Ren-O-Lyzed are still in use after 1 year's time! Each Ren-O-Lyzing job at \$9.95 is creating an average \$120.00 weekly increased income for every Ren-O-Lyzer unit in use. The TUBE-CHECKER eliminates all guesswork, proving to the customer IN THE HOME, the need for replacement of defective tubes. Order today . . . don't delay this opportunity for increased income. Instruments extremely simple to operate.



Send me name of nearest dealer and further details.

955 R-E

Name _____

Address _____

City _____

Zone _____ State _____