



Service Manual

Nakamichi

OMS-5 OMS-5E OMS-50

Compact Disc Player

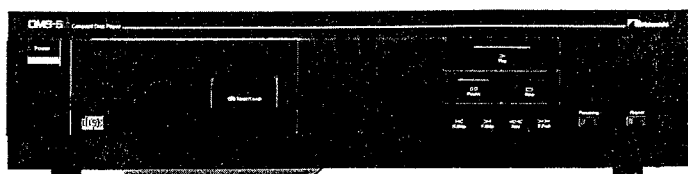

CONTENTS

1.	General	2
2.	Pickup Replacement Procedures	2
2. 1.	Notice in Handling Pickup	2
2. 2.	Pickup Replacement Procedures	2
2. 3.	Adjustment After Replacement of Pickup	3
3.	Measurement Instruments and Test Discs	4
4.	Parts Location for Adjustment	4
4. 1.	Parts on P.C.B. Ass'y	4
4. 2.	Parts on Pickup	4
5.	Adjustments	5
5. 1.	Notes	5
5. 2.	Adjustment Instructions	5
6.	Mechanism Ass'y and Parts List	10
6. 1.	Synthesis	10
6. 2.	Front Panel Ass'y (A01)	11
6. 3.	Chassis Ass'y (A02)	12
6. 4.	Disc Mechanism Ass'y (B01)	13
6. 5.	Rear Panel Ass'y (B02)	15
6. 6.	Disc Mechanism Sub Ass'y (C01)	15
6. 7.	Analog Processor Unit (D01)	16
7.	Mounting Diagrams and Parts List	17
7. 1.	Photo Transistor P.C.B. Ass'y	17
7. 2.	Photo Diode P.C.B. Ass'y	17
7. 3.	Open End Switch P.C.B. Ass'y	17
7. 4.	Close End Switch P.C.B. Ass'y	17
7. 5.	Eject/Load Switch P.C.B. Ass'y	17
7. 6.	Power Switch P.C.B. Ass'y	17
7. 7.	Remote Control P.C.B. Ass'y	17
7. 8.	Pin Jack P.C.B. Ass'y	18
7. 9.	FL Indicator P.C.B. Ass'y	18
7. 10.	Auto Power Control P.C.B. Ass'y	19
7. 11.	RF Pre-Amp. P.C.B. Ass'y	20
7. 12.	Power Supply P.C.B. Ass'y	21
7. 13.	Control Switch P.C.B. Ass'y	22
7. 14.	Analog Processor P.C.B. Ass'y	22
7. 15.	D/A Converter P.C.B. Ass'y	23
7. 16.	Main P.C.B. Ass'y	26
8.	Schematic Diagram	27
8. 1.	IC Block Diagrams and Descriptions	27
8. 2.	Waveforms at Major Points	37
8. 3.	Schematic Diagram	38
9.	Wiring Diagram	39
10.	Block Diagram	40
11.	Specifications	41

1. GENERAL

1.1. Voltage Selector

Voltage selector is installed on the rear panel for Other version of the Nakamichi OMS-5. This voltage selector can select either 120 V or 220-240 V at customer's disposal.

1.2. Packing Materials and Owner's Manual

Part No.	Description	Q'ty
0C81048A	Outer Carton OMS-5	1
0C81083A	Outer Carton OMS-5E	1
0C81084A	Outer Carton OMS-50 (Japan)	1
0C81049A	Inner Carton OMS-5	1
0C81087A	Inner Carton OMS-5E	1
0C81088A	Inner Carton OMS-50 (Japan)	1
0C81051A	Side Packing L	1
0C81050A	Side Packing R	1
0C81052A	Mirror Mat Bag	1
0D04491A	Owner's Manual OMS-7 & OMS-5 (English)	1
0D04493A	Owner's Manual OMS-7/7E & OMS-5/5E (English/German/French)	1
0D04492A	Owner's Manual OMS-70/50 (Japanese)	1

WARNING:

To protect eyes from laser beam during servicing, DO NOT LOOK AT THE LASER BEAM.

Note: Laser Diode Properties

Material:	GaAlAs
Wavelength:	790 nm — 820 nm
Emission Duration:	continuous
Laser Output:	0.7 mW max.
Classification:	Class III b

2. PICKUP REPLACEMENT PROCEDURES

2.1. Notice in Handling Pickup

In case of repair or replacement of the Pickup, pay attention to the following handling instructions since the laser diode in the Pickup is not resistant to static electricity.

- (1) Repair or replace on a work stand on which the conducting rubber is spread.
- (2) Use ceramic soldering iron with GND.
- (3) Since Pickup is supplied as a spare part in a conductive bag, take it out of the bag only when you need it.
- (4) Remove the shorting pin and conductive sponge that short the connector pins of the Pickup after entire work is completed.
- (5) Do not turn the adjustment screws (Focus Screw, RF Signal Phase Screw and Tracking Screw) of the Pickup. If they are turned widely, it may take much time to readjust them.

2.2. Pickup Replacement Procedures

- (1) Place the Compact Disc Player upside down on the work stand and remove the Bottom Cover by unfastening 10 screws.
- (2) Rotate the pulley of the Disc Mechanism Ass'y to move the Pickup in the direction of the arrow. See Fig. 2.1.
- (3) Remove F01, F02 and F03, and pull out F04. See Fig. 2.2.
- (4) Remove F05, F06 and F07, and pull out F08. See Fig. 2.3.

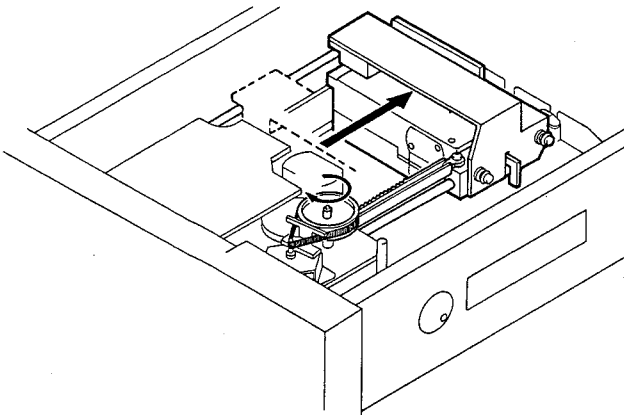

Fig. 2.1

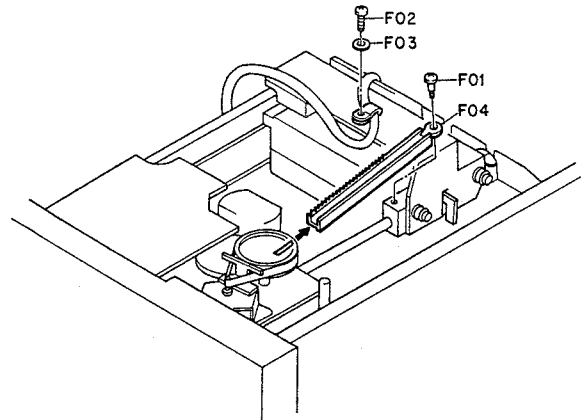

Fig. 2.2

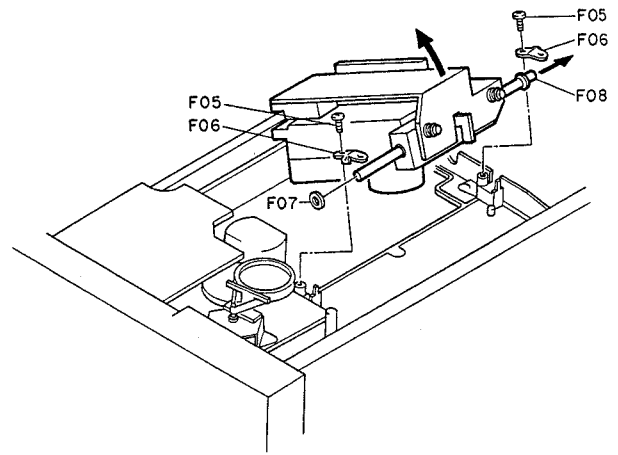

Fig. 2.3

- (5) Remove two connectors, unsolder the two-core shield cable, and unsolder F09 to separate F09 from the Pickup. See Fig. 2.4.
- (6) Loosen F10 and remove F11 (Pickup). See Fig. 2.5.
- (7) Mount a new Pickup and temporarily fasten it with F10. See Fig. 2.5.
- (8) Remove the conductive sponge of the new Pickup.
- (9) Mount F09 on the new Pickup by soldering. Plug in the two connectors and solder the two-core shield cable to the original place. Soldering of the shield cable must be made in the order of GND wire with black tube and then signal wires.
- (10) Mount the new Pickup by reversing the disassembly procedures.
- (11) Pull F12 (shorting pin) out of the Pickup. See Fig. 2.6.

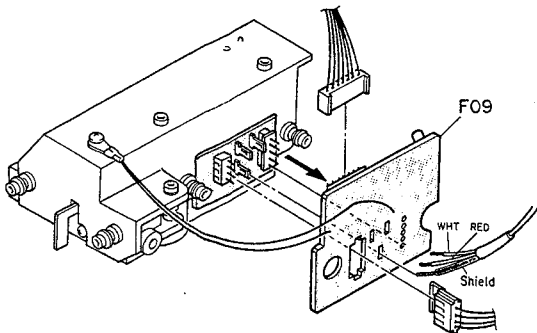

Fig. 2.4

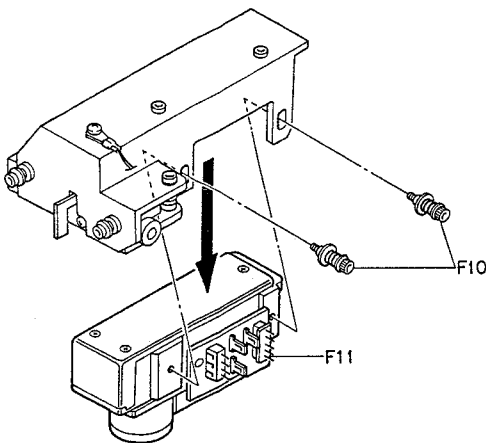

Fig. 2.5

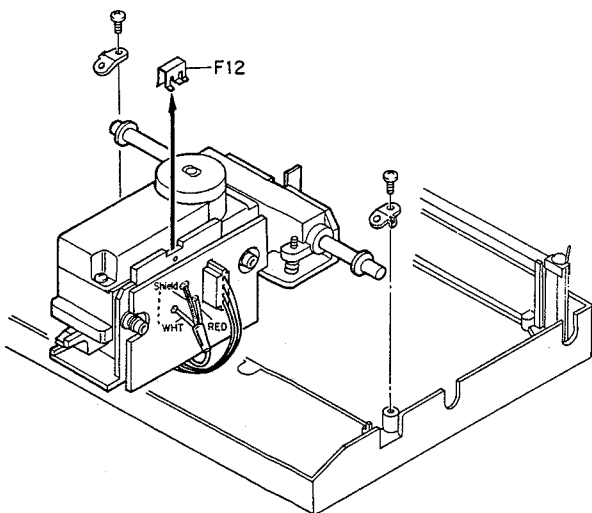

Fig. 2.6

2.3. Adjustment After Replacement of Pickup

Upon completion of replacement of the Pickup, perform rough adjustments following the flow chart shown in Fig. 2.7. Then proceed to the final stage adjustment, i.e., "Adjustment Instructions" in item 5.2 except step 1 "Laser Power Adjustment" (step 1 is already done in the rough adjustment).

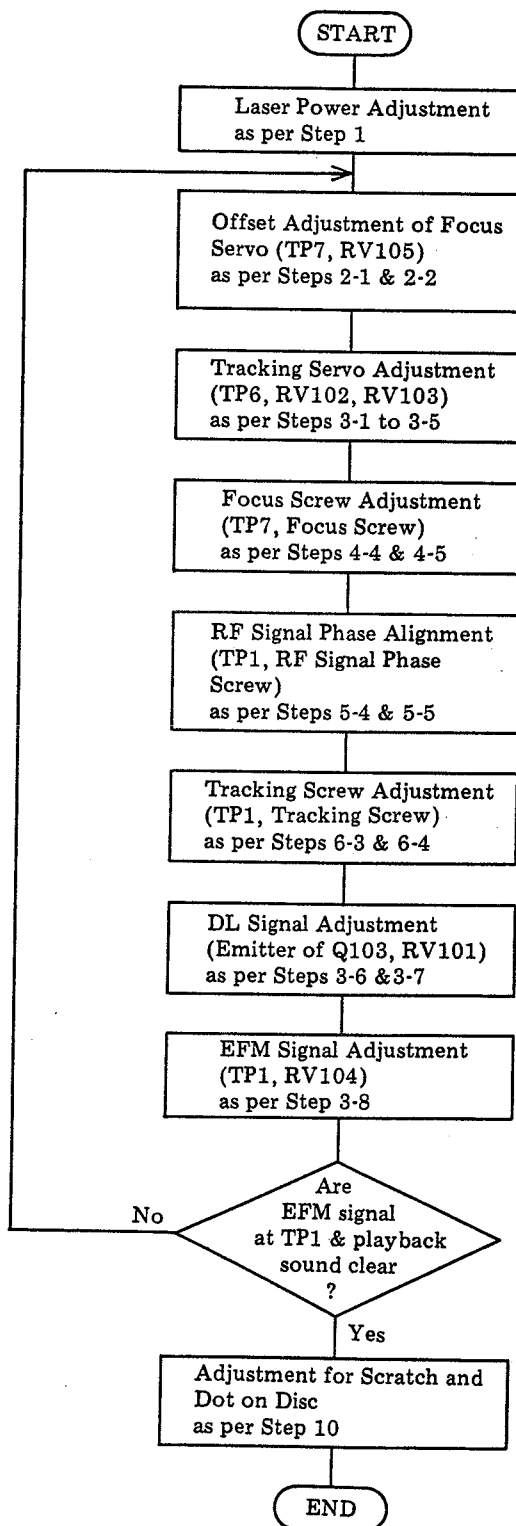

Fig. 2.7

3. MEASUREMENT INSTRUMENTS AND TEST DISCS

- (1) Synchroscope (15 MHz or more)
- (2) VTVM
- (3) DC Voltmeter
- (4) Optical Power Meter
- (5) Philips Test Sample Disc 5A
- (6) Sony Test C.D. YEDS-7

- (7) LPF (Low Pass Filter):
Pass Band — 4 Hz to 20 kHz, Attenuation — 60 dB or more
for 24.1 kHz or higher frequency
Recommended LPF: Philips Type 7122 780 29020
- (8) Distortion Meter

4. PARTS LOCATION FOR ADJUSTMENT

4.1. Parts on P.C.B. Ass'y

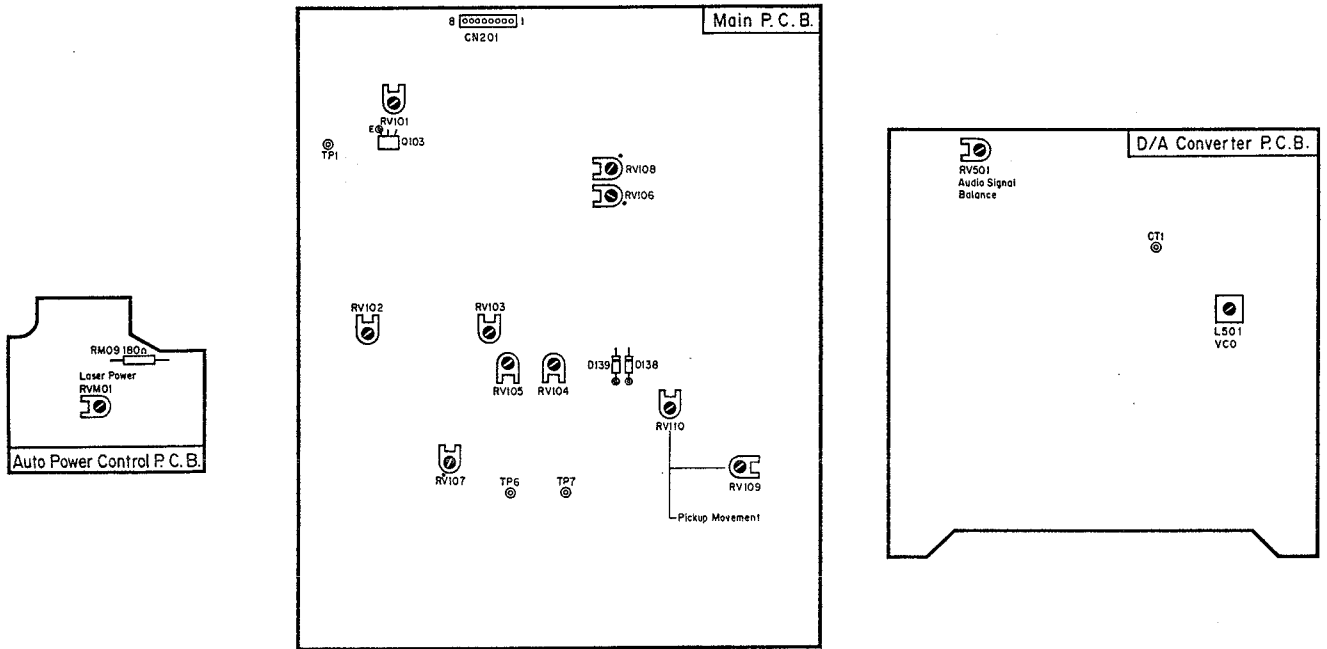

Fig. 4.1

4.2. Parts on Pickup

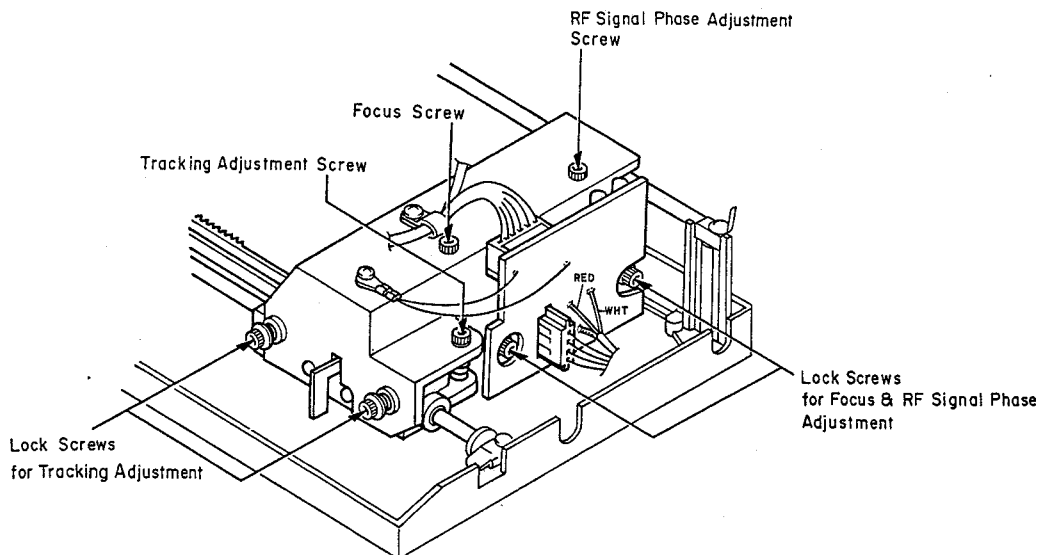

Fig. 4.2

5. ADJUSTMENTS

5.1. Note

Pay attention to the following before adjustment.

- (1) Keep the Compact Disc Player horizontal during adjustment.
- (2) Before starting adjustment, allow three minutes after the power is turned ON. Offset voltage will be stabilized in this period of time.
- (3) When a Philips 5A test disc is used, perform the adjustment while listening to the playback sound.
- (4) Connect a low pass filter (pass band: 4 Hz to 20 kHz) in series to the distortion meter to be used.
- (5) When the Main P.C.B. Ass'y is replaced with new one, set each of the potentiometers as follows:
 - RV106, RV107: 1 o'clock direction (marked on the P.C.B.)
 - RV108: 10 o'clock direction (marked on the P.C.B.)
 - Others: Mechanical center positions

- (6) Potentiometers that are not stated in the adjustment instructions must be set to the preset positions stated in (5).
- (7) When the Auto Power Control P.C.B. Ass'y or Pickup is replaced with new one, turn the potentiometer RVM01 full counterclockwise to prevent damage to the Pickup.
- (8) Keep the Pickup Lens clean. Carefully clean it with lens cleaner or similar tools.

Danger: Invisible laser radiation when opened and interlock failed or defeated. Avoid direct exposure to beam.

5.2. Adjustment Instructions

STEP	ITEM	SIGNAL SOURCE	OUTPUT CONNECTION	ADJUSTMENT	REMARKS
1	Laser Power Adjustment	None	Optical Power Meter to Pickup Lens or DC Voltmeter across RM09 on Auto Power Control P.C.B.	Auto Power Control P.C.B. RVM01	<p>1. Using Optical Power Meter</p> <ol style="list-style-type: none"> a. Unsolder one of the leads of diode D135 on the Main P.C.B. Ass'y. b. See Fig. 5.1. Remove the Feed Motor Belt and, with rotating the Pulley, position the Pickup so that an optical power meter can be put onto the lens of the Pickup. Position the optical power meter at such a position and angle that provide maximum power meter reading. c. Check that RVM01 is at full counterclockwise position, and then turn ON the power. d. Rotate RVM01 slowly clockwise until the power meter reads 0.27 mW. Caution: Use care not to exceed 0.3 mW at any moment, otherwise Pickup will be damaged. e. Turn OFF the power and then solder the lead of D135 and put the belt on the feed motor. <p>2. Without using Optical Power Meter</p> <ol style="list-style-type: none"> a. Unsolder one of the leads of diode D135 on the Main P.C.B. Ass'y. b. Connect a DC voltmeter across RM09 (180-ohm 1 W) on the Auto Power Control P.C.B. Ass'y. c. Check that RVM01 is at full counterclockwise position, and then turn ON the power. d. Rotate RVM01 slowly clockwise until the reading on the DC voltmeter reaches 90% of the operating current I_{op}. I_{op} is marked on the Pickup (however, it is actually marked as I_o). Example: If I_{op} is 37 mA, the voltmeter reading which corresponds to 90% of I_{op} is $0.037 (A) \times 0.9 \times 180 (ohms) = 5.99 (V)$. Caution: Use care not to exceed I_{op} at any moment, otherwise the Pickup will be damaged. In this example ($I_{op} = 37$ mA), the limit is 6.66 V. e. Turn OFF the power and then solder the lead of D135.

STEP	ITEM	SIGNAL SOURCE	OUTPUT CONNECTION	ADJUSTMENT	REMARKS
2	Focus Servo Adjustment	Test Disc Philips 5A	Synchroscope to TP1, TP7 on Main P.C.B.	Main P.C.B. RV104, RV105	<ol style="list-style-type: none"> 1. Set a synchroscope to DC input and 50 mV/div., and connect it to TP7. 2. Adjust RV105 to obtain 0+50 mV on the synchroscope. 3. Connect the synchroscope to TP1 and play back the test disc. 4. While listening to the playback sound, adjust RV104 so that the horizontal waving of the EFM (Eight-to-Fourteen Modulation) signal at TP1 is minimized and the EFM signal waveform becomes clear. See Fig. 5.2.
3	Tracking Servo Adjustment	Test Disc Philips 5A	Synchroscope to TP1, TP6, emitter of Q103 on Main P.C.B.	Main P.C.B. RV101, RV102, RV103, RV104	<ol style="list-style-type: none"> 1. Set a synchroscope to DC input and 50 mV/div., and connect it to TP6. 2. Adjust RV103 to obtain 0-100 mV on the synchroscope. 3. Short between pins 4 (A+C signal) and 5 (GND) of CN201 and between pins 6 (GND) and 7 (B+D signal) of CN201 on the Main P.C.B. Ass'y. Short between the emitter and the base of Q113 on the Main P.C.B. Ass'y. 4. Adjust VR102 to obtain 0-50 mV on the synchroscope. 5. Remove the short of CN201 and Q113. 6. Connect the synchroscope to the emitter of Q103 and play back the test disc. 7. Adjust RV101 to obtain minimum DL signal (RF error signal) on the synchroscope. 8. Connect the synchroscope to TP1 and, while listening to the playback sound, adjust RV104 so that EFM signal is maximized and becomes clear.
4	Focus Screw Adjustment	Test Disc Philips 5A	Synchroscope to TP7 on Main P.C.B.	Main P.C.B. RV105 Focus Screw	<ol style="list-style-type: none"> 1. Loosen the two Lock Screws used for focus adjustment by referring to Fig. 4.2. 2. Set a synchroscope to DC input and 50 mV/div., and connect it to TP7. 3. Adjust RV105 to obtain 0+50 mV on the synchroscope. 4. Play back the 7th or 8th music on the test disc. 5. While listening to the playback sound, adjust the Focus Screw of the Pickup to obtain exactly or approximately 0 V on the synchroscope. 6. After completion of adjustment, securely tighten the Lock Screws alternately.

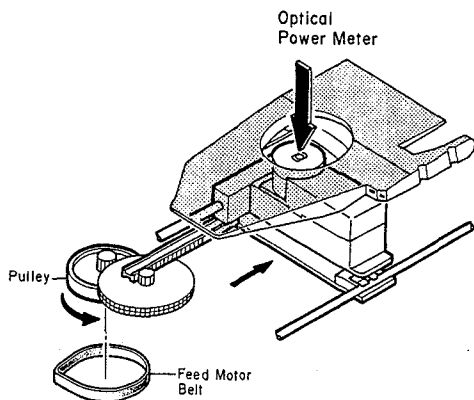

Fig. 5.1

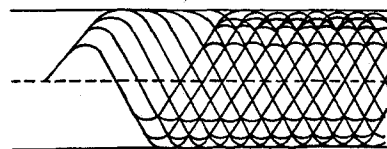

Fig. 5.2 EFM Signal at TP1

STEP	ITEM	SIGNAL SOURCE	OUTPUT CONNECTION	ADJUSTMENT	REMARKS
5	RF Signal Phase Adjustment	Test Disc Philips 5A	Synchroscope to TP1 on Main P.C.B.	Main P.C.B. RV104 RF Signal Phase Screw	<ol style="list-style-type: none"> 1. Loosen the two Lock Screws used for RF signal phase alignment by referring to Fig. 4.2. 2. Connect a synchroscope to TP1 and play back the test disc. 3. While listening to the playback sound, adjust RV104 so that the horizontal waving of the EFM signal at TP1 is minimized and the EFM signal becomes clear. 4. Play back the 7th or 8th music on the test disc. 5. Adjust the RF Signal Phase Screw of the Pickup so that the EFM signal waveform at TP1 becomes clear and maximized and that its horizontal waving is minimized. 6. Repeat 2. to 5. above two or three times. 7. Securely tighten the Lock Screws alternately.
6	Tracking Screw Adjustment	Test Disc Philips 5A	Synchroscope to TP1, TP6, emitter of Q103 on Main P.C.B.	Tracking Screw Main P.C.B. RV101, RV102 RV103, RV104	<ol style="list-style-type: none"> 1. Loosen the two Lock Screws used for tracking adjustment by referring to Fig. 4.2. 2. Conduct step 3 "Tracking Servo Adjustment". 3. Connect a synchroscope to TP1 and play back the 7th or 8th music on the test disc. 4. While listening to the playback sound, adjust the Tracking Screw of the Pickup so that the EFM signal at TP1 becomes clear and maximized. 5. Connect the synchroscope to the emitter of Q103 and adjust RV101 to obtain minimum DL signal on the synchroscope. 6. While listening to the playback sound, adjust RV104 so that the EFM signal at TP1 is maximized and becomes clear. 7. Securely tighten the Lock Screws alternately.
7	VCO Adjustment	Test Disc Philips 5A	Synchroscope to test point CT1 on D/A Converter P.C.B.	D/A Converter P.C.B. L501	<ol style="list-style-type: none"> 1. Connect a synchroscope to the test point CT1 and play back the 18th music, Finger Print, on the test disc. 2. While listening to the playback sound and observing the VCO signal level on the synchroscope, turn the core of L501 counterclockwise and clockwise to find out the upper and the lower limits of VCO voltage, i.e., the limits at which the playback sound is about to cut off. 3. Adjust the core of L501 so that the VCO level is the midpoint between the upper and lower limit voltages. (This VCO level will be approx. a little under 5.0 V).
8	Pickup Movement Adjustment	Test Disc Philips 5A	Synchroscope to anode of D138 (or pin 3 of U115), anode of D139 (or pin 11 of U115) on Main P.C.B.	Main P.C.B. RV109, RV110	<ol style="list-style-type: none"> 1. Connect a synchroscope to the anode of the diode D138. 2. Play back the test disc and then press the F. Fwd button to set the Compact Disc Player in Cue mode. 3. Adjust RV109 to obtain a 180 μsec pulse width. See Fig. 5.3.1. 4. Press the F. Fwd button further several times, and check whether the time indication on the Time Indicator regularly increases. If not, repeat 3. 5. Connect the synchroscope to the anode of diode D139. 6. Play back the test disc and then press the Rev button to set the Compact Disc Player in Cue mode. <p>(to be continued)</p>

STEP	ITEM	SIGNAL SOURCE	OUTPUT CONNECTION	ADJUSTMENT	REMARKS
					7. Adjust RV110 to obtain a 160 μ sec pulse width. See Fig. 5.3.2. 8. Press the Rev button further several times, and check whether the Time Indicator regularly changes its time indication. If not, repeat 7.
9	Audio Signal Balance Adjustment	Test Disc Sony YEDS-7	VTVM to Output Pin Jacks	D/A Converter P.C.B. RV501	1. Play back the first music on the test disc to play back 1 kHz 0 dB level signals. 2. Measure both L and R channel output levels and adjust RV501 so that the difference between them is less than 0.1 V.
10	Adjustment for Scratch and Dot on Disc	Test Disc Philips 5A	Synchroscope to TP1 on Main P.C.B.	Main P.C.B. RV104	1. Scratch 900 μm Play back the 9th music with a 900 μ m scratch on the test disc and listen to the playback sound. If playback is not made properly, conduct step 6 "Tracking Screw Adjustment". Turn the Tracking Screw counterclockwise when tracking stops, but turn it clockwise when track is skipped. If still proper playback is not made yet, conduct step 7 "VCO Adjustment". 2. Black Dot 800 μm Play back the 17th music with a 800 μ m black dot on the test disc. If playback is not made properly, that is, if tracking stops, make the following adjustment: 1. Set a synchroscope to 1 msec/div. and connect it to TP1. 2. Adjust RV104 so that the waveform at TP1 is as shown in Fig. 5.4.2 when passing through a black dot.

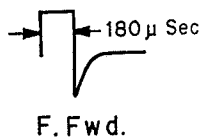

Fig. 5.3.1

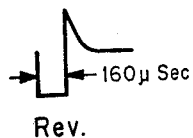

Fig. 5.3.2

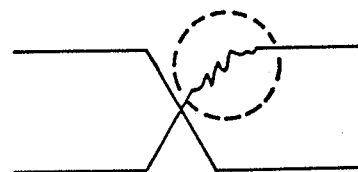

Fig. 5.4.1 Before Adjustment

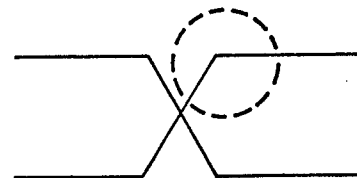

Fig. 5.4.2 After Adjustment

STEP	ITEM	SIGNAL SOURCE	OUTPUT CONNECTION	ADJUSTMENT	REMARKS
11	Tracking Adjustment with Eccentric Disc	Approx. 0.1mm Eccentric Disc	Positive side of C173 on Main P.C.B.	Main P.C.B. RV108,RV109 RV110	<p>Perform this adjustment only if a disc with eccentricity is not played back properly.</p> <p>Precisely re-adjust Step 3 "Tracking Servo Disc Adjustment" and Step 6 "Tracking Screw Adjustment", and check whether playback is made properly. If not, perform the following adjustment to insure correct tracking for a 0.1 mm eccentric disc.</p> <ol style="list-style-type: none"> Preparation for 0.1 mm Eccentric Disc <ul style="list-style-type: none"> Find a disc with approx. 0.1 mm eccentricity in the following manner: <ol style="list-style-type: none"> Set a synchroscope to DC input and connect it to the positive side of C173 on the Main P.C.B. Ass'y. Play back the first music on eccentric discs and press the Pause button to set the Compact Disc Player in Pause mode. Then observe the peak-to-peak level (Vpp) on the synchroscope. The amount of eccentricity, X (mm), is given in the following formula: $X = 1/2 \times (1.3 \times (V_{pp}/(5.8 + 4.7)))$ <p>where, 1.3 mm/A: sensitivity of Tracking Servo 5.8 ohms: DC resistance value of Tracking Coil 4.7 ohms: value of resistor R197</p> <p>If amount of eccentricity (X) is assumed to be 0.1 mm,</p> $V_{pp} = 2 \times (5.8 + 4.7)/1.3 \times 0.1 = 1.6 \text{ (V)}$ <p>That is, the disc which shows approx. 1.6 V on the synchroscope should be selected.</p> Load the disc found in 1 above and play back the first music of the disc. Check whether it takes much time to enter Standby mode or whether the time indication of the Time Indicator begins with 00:00. If not, re-adjust Step 3 "Tracking Servo Adjustment" and then turn RV108 approx. 10 degrees in the counterclockwise direction. During playback, press the F. Fwd button several times and check that the time indication of the Time Indicator regularly increases. If not, turn RV109 to correct it. Next, during playback, press the Rev button several times to see whether the time indication of the Time Indicator regularly decreases. If not, turn RV110 to correct it.

6. MECHANISM ASS'Y AND PARTS LIST

6.1. Synthesis

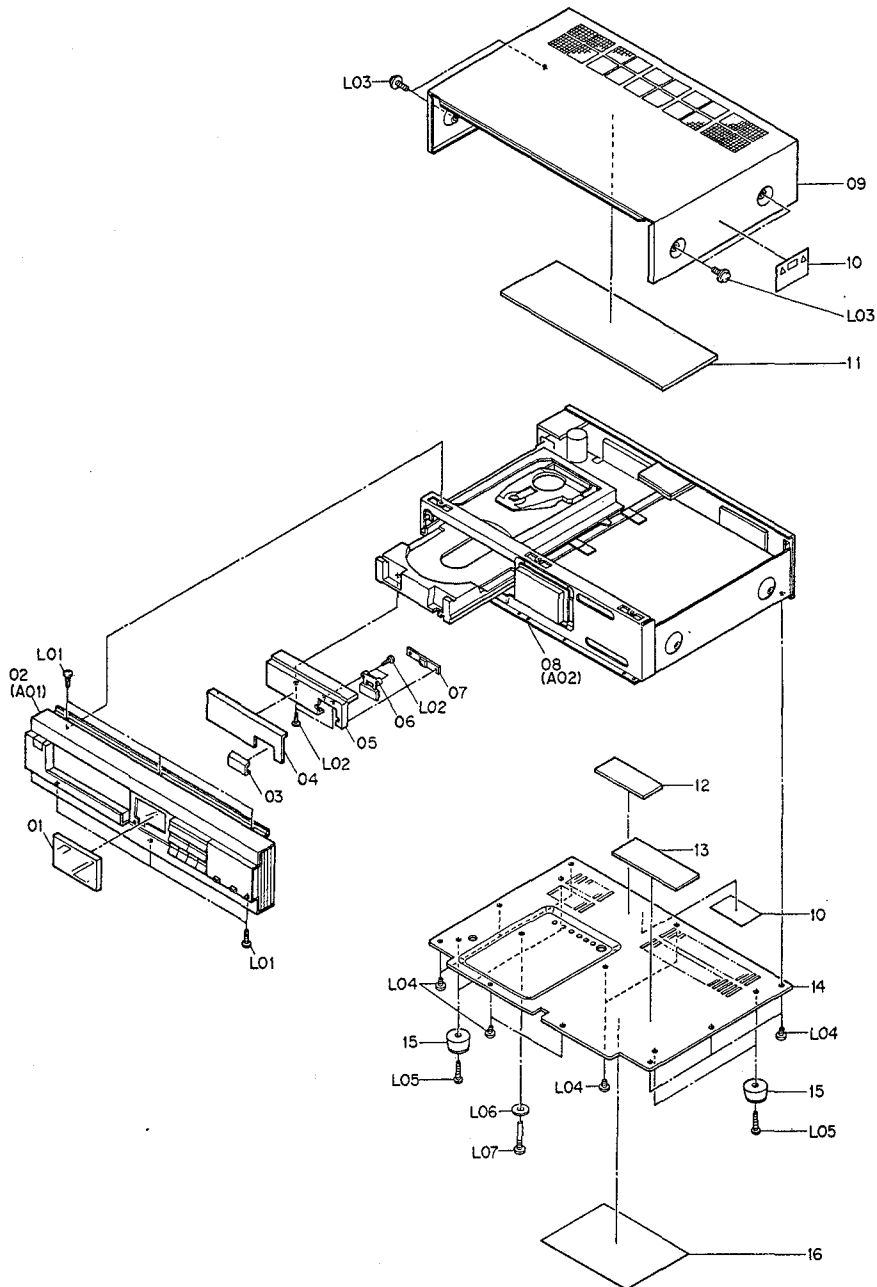

Fig. 6.1

Schematic Ref. No.	Part No.	Description	Q'ty	Schematic Ref. No.	Part No.	Description	Q'ty
		Synthesis		14	OC80721A	Bottom Cover	1
				15	OC80722A	Leg	4
				16	OM04621B	Caution Label B	1
01	OC81206A	Indicator Lens	1	L01	OE00921A	BT 3x8 @ Binding (Black Chromate)	6
02	CA80295A	Front Panel Ass'y OMS-5	1	L02	OE00855A	BT 2.6x6 @ Binding	2
	CA80296A	Front Panel Ass'y OMS-5E	1	L03	OC81064A	M4x8 @ Pan Washer-faced (Black Chromate)	4
	CA80297A	Front Panel Ass'y OMS-50	1	L04	OE00970A	M3x4 @ Binding	8
03	OC80715A	Eject Button	1	L05	OE00888A	BT 3x12 @ Binding	4
04	OC80716A	Lid	1	L06	OC81267A	Shipping Washer	1
05	OC80717A	Lid Frame	1	L07	OC81095A	Shipping Screw	1
06	OC80718A	Eject Button Base	1				
07	CA80237A	Eject/Load Switch P.C.B. Ass'y	1				
08	—	Chassis Ass'y	1				
09	OC80719A	Top Cover	1				
10	OM04377A	Caution Label A	2				
11	OC80720A	Vibration Isolating Sheet A	1				
12	OC81062A	Vibration Isolating Sheet B (except U.S.A.)	1				
13	OC81063A	Vibration Isolating Sheet C (U.S.A.)	1				

6.2. Front Panel Ass'y (A01)

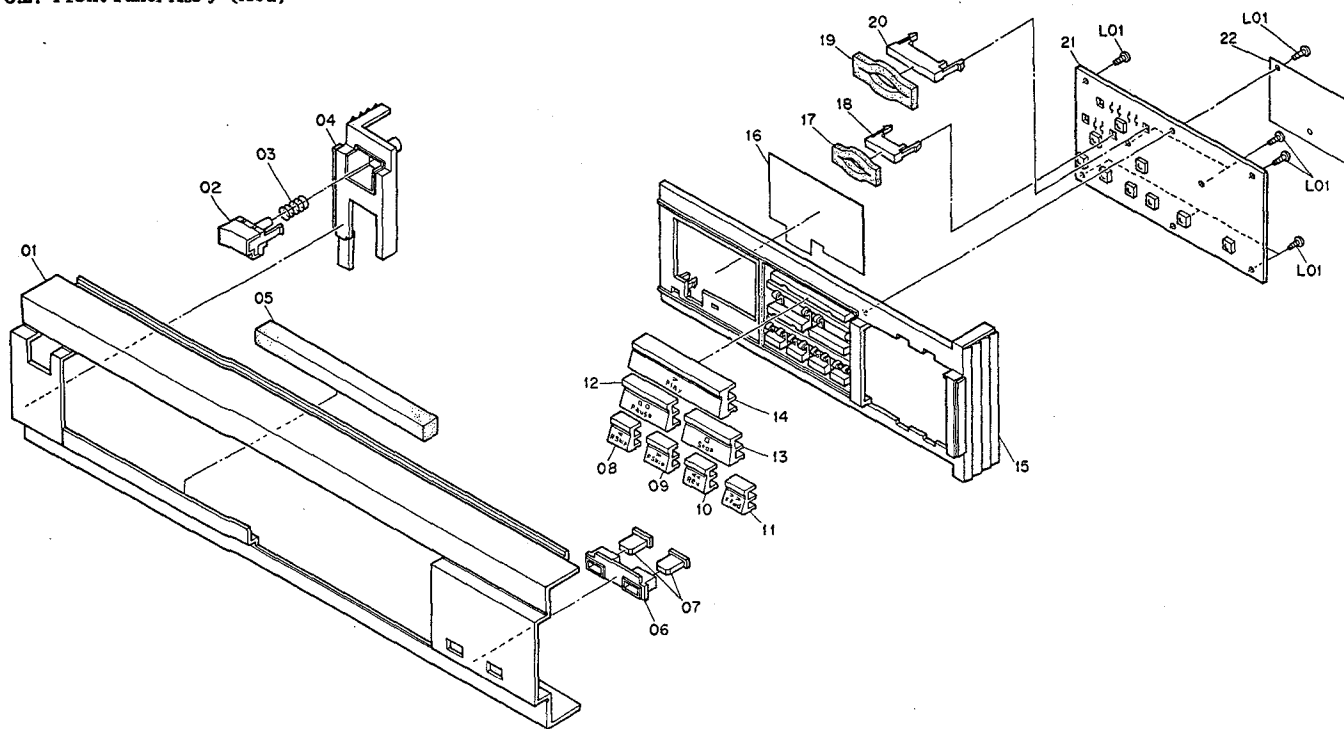

Fig. 6.2

Schematic Ref. No.	Part No.	Description	Qty
A01	CA80295A	Front Panel Ass'y OMS-5	1
	CA80296A	Front Panel Ass'y OMS-5E	1
	CA80297A	Front Panel Ass'y OMS-50	1
01	0C81351A	Front Panel OMS-5	1
	0C81352A	Front Panel OMS-5E	1
	0C81353A	Front Panel OMS-50	1
02	CA80355A	Power Button Ass'y	1
03	0C80723A	Spring	1
04	0C80724A	Side Frame L	1
05	0C80725A	Sponge	1
06	0C81377A	Button Guide	1
07	0C80726A	Push Button	2
08	0C81367A	R. Skip Button	1
09	0C81366A	F. Skip Button	1
10	0C81369A	Rev Button	1
11	0C81368A	F. Fwd Button	1
12	0C81365A	Pause Button	1
13	0C81364A	Stop Button	1
14	0C81363A	Play Button	1
15	0C81370A	Side Frame R	1
16	0C80706A	FL Filter	1
17	0C81375A	Sponge B	1
18	0C80707A	LED Holder	1
19	0C81376A	Sponge C	1
20	0C80708A	LED Holder B	1
21	CA80244A	Control Switch P.C.B. Ass'y	1
22	0C81371A	Insulator	1
L01	0E00792A	BT 2.6x6 @ Binding	8

6.3. Chassis Ass'y (A02)

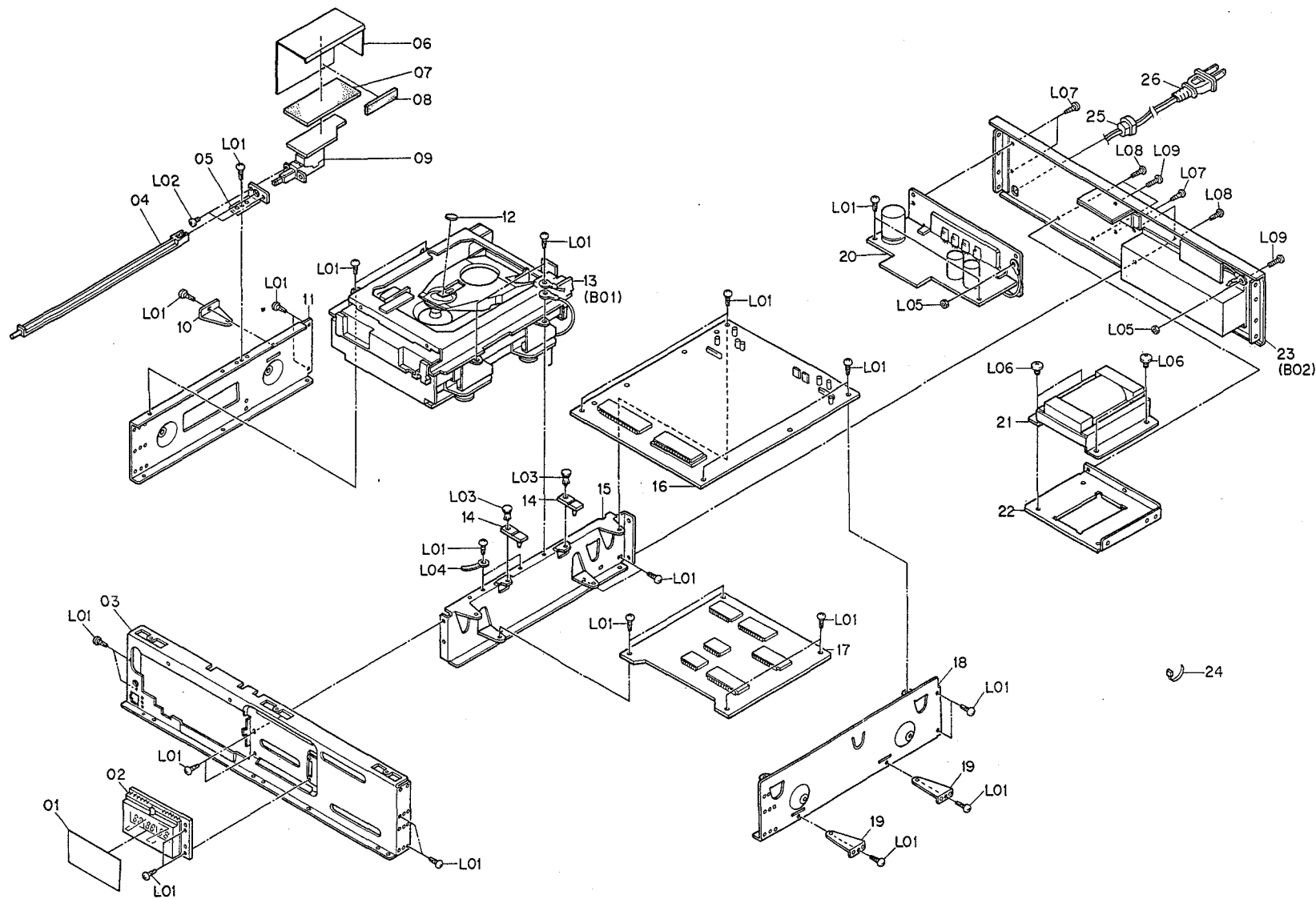

Fig. 6.3

Schematic Ref. No.	Part No.	Description	Qty
A02	—	Chassis Ass'y	1
01	OC80689A	FL Filter A	1
02	CA80243A	FL Indicator P.C.B. Ass'y	1
03	OC80691A	Front Chassis	1
04	OC80693A	Joint Bar	1
05	OC80694A	Power Switch Bracket	1
06	OC80695A	Power Switch Insulator	1
07	OC80696A	Power Switch Sponge A	1
08	OC80697A	Power Switch Sponge B	1
09	CA80240A	Power Switch P.C.B. Ass'y	1
10	OC80698A	P.C.B. Bracket L	1
11	OC80699A	Side Chassis L	1
12	OC81066A	Damper Spring	1
13	CA80256A	Disc Mechanism Ass'y	1
14	OC81065A	Hinge	2
15	OC80700A	Center Chassis	1
16	CA80303A	Main P.C.B. Ass'y	1
17	CA80233A	D/A Converter P.C.B. Ass'y	1
18	OC80701A	Side Chassis R	1
19	OC80702A	P.C.B. Bracket R	2
20	CA80232A	Power Supply P.C.B. Ass'y	1
21	OC80760A	Power Transformer 100V (Japan)	1
	OC80761A	Power Transformer 120V (U.S.A. & Canada)	1
	OC80762A	Power Transformer 220V (220V Class 2)	1
	OC80763A	Power Transformer 240V (Australia)	1
	OC80764A	Power Transformer 110V/220-240V (Others)	1
22	OC80703A	Power Transformer Bracket	1
23	CA80298A	Rear Panel Ass'y OMS-50 (Japan)	1
	CA80299A	Rear Panel Ass'y OMS-5 (U.S.A., Canada & Australia)	1
	CA80300A	Rear Panel Ass'y OMS-5E	1
	CA80302A	Rear Panel Ass'y OMS-5 (Others)	1
24	OB08515A	Insu-Lock	1
25	OB08037U	Cord Bushing	1
26	OC81208A	Power Cord (Japan)	1
	OC81209A	Power Cord (U.S.A., Canada & Others)	1
	OC81210A	Power Cord (220V Class 2)	1
	OC81211A	Power Cord (Australia)	1
—	OB08347U	Fuse T1A 250V (220V Class 2)	2
—	OB08457A	Fuse T500mA 250V (220V Class 2)	2
L01	OC81033A	BT 3x8 @ Round	34
L02	OE00522A	M3x4 @ Pan	2
L03	OE08583A	Plastic Rivet	2
L04	OC80704A	Wire Clamp	1
L05	OC00507A	Nut Hex. M3	2
L06	OE00558A	M4x6 @ Pan	4
L07	OE00921A	BT 3x8 @ Binding (Black Chromate)	3
L08	OC81032A	BT 3x8 @ Nailtap Screw (Black Chromate)	4
L09	OE00818A	M3x8 @ Binding (Black Chromate)	2

6.4. Disc Mechanism Ass'y (B01)

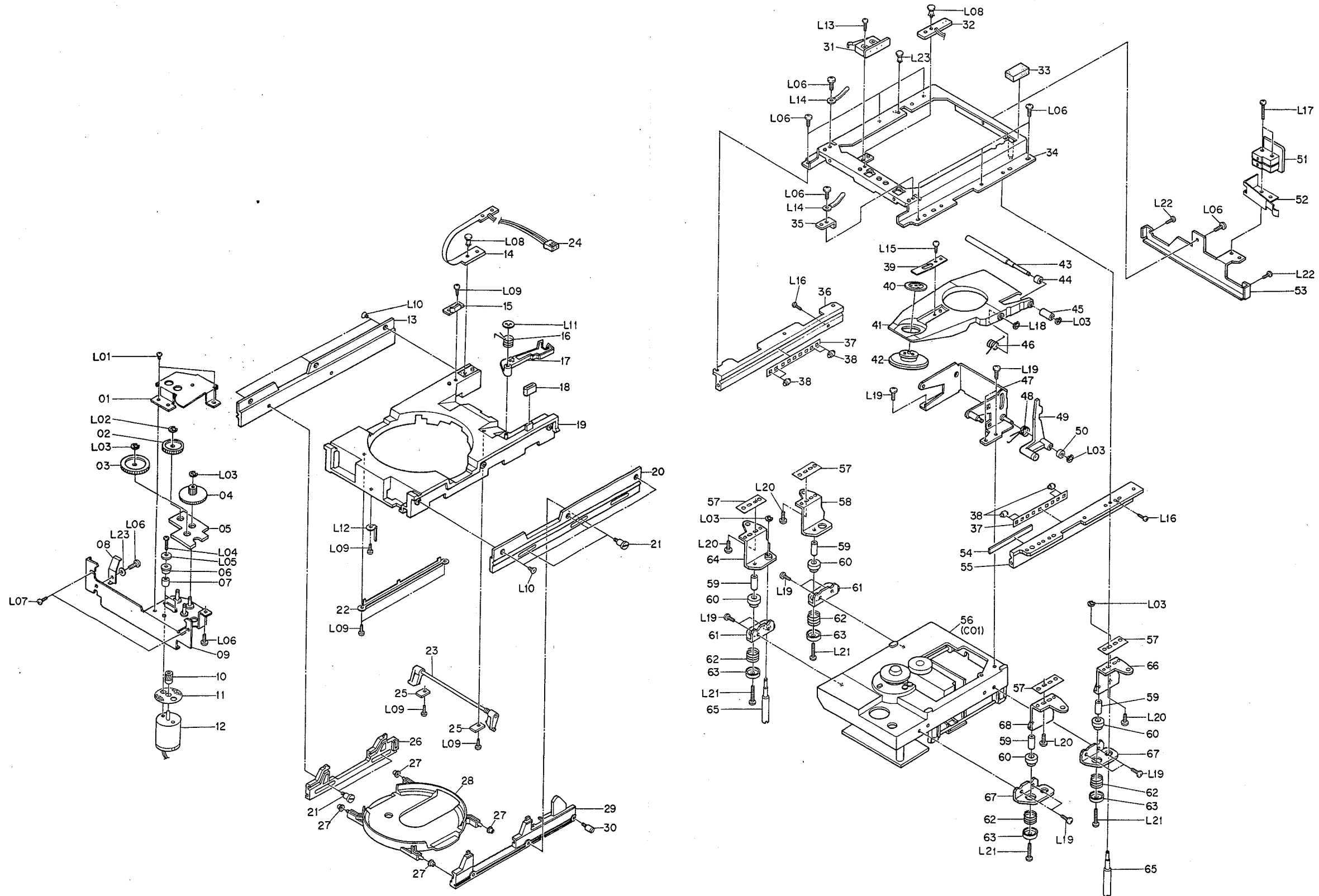

Fig. 6.4

Schematic Ref. No.	Part No.	Description	Q'ty	Schematic Ref. No.	Part No.	Description	Q'ty
B01	CA80256A	Disc Mechanism Ass'y	1	L14	0C80991A	Wire Clamp	2
01	0C81156A	Gear Cover	1	L15	0C80939A	BT 2.6x4 @ Nailtap Screw (Black Chromate)	1
02	0C80998A	Gear A	1	L16	0C80964A	M2x6 @ Pan	2
03	0C80997A	Gear B	1	L17	0C80956A	M2x16 @ Pan	2
04	0C80996A	Gear C	1	L18	0E00698A	E-Ring 2.5mm	1
05	0C81005A	Damper A	1	L19	0E03030A	M3x6 @ Binding (Nickel)	11
06	0C80995A	Bushing	2	L20	0E00818A	M3x8 @ Binding (Black Chromate)	4
07	0C80984A	Spacer	2	L21	0E00514A	M3x15 @ Pan	4
08	0C80972A	Spring	1	L22	0E03175A	M2.6x6 @ Pan (Black Chromate)	2
09	CA80283A	Gear Bracket Ass'y	1	L23	0C80953A	Plastic Rivet	1
10	0C81001A	Gear M	1				
11	0C81006A	Sheet	1				
12	0C81360A	Loading Motor	1				
13	0C80982A	Box Rail L	1				
14	0C81058A	Flexible P.C.B.	1				
15	0C80971A	Switch Plate	1				
16	0C81145A	Lock Arm Spring	1				
17	0C81007A	Lock Arm	1				
18	0C80999A	Cushion	1				
19	0C80994A	Disc Drawer	1				
20	0C80981A	Box Rail R	1				
21	0C80985A	Guide Screw A	4				
22	0C81149A	Cord Cover	1				
23	CA80354A	Rack Arm Ass'y	1				
24	CA80279A	2P Connector Cord Ass'y	1				
25	0C80976A	Rack Arm Plate	2				
26	0C81009A	Rack B	1				
27	0C81143A	Table Roller	4				
28	0C81010A	Disc Tray	1				
29	0C81008A	Rack A	1				
30	0C80983A	Guide Screw B	2				
31	CA80239A	Open End Switch P.C.B. Ass'y	1				
32	CA80234A	Photo Diode P.C.B. Ass'y	1				
33	0C81350A	Sponge	1				
34	CA80280A	Box Guide Ass'y	1				
35	0C80973A	Stopper	1				
36	0C80975A	Guide Rail L	1				
37	0C81003A	Roller Guide	2				
38	0C81000A	Roller	8				
39	0C80941A	Chuck Spring	1				
40	0C80940A	Chuck B	1				
41	0C80949A	Chuck Arm	1				
42	0C80948A	Chuck A	1				
43	0C80942A	Arm Shaft	1				
44	0C80946A	Collar B	1				
45	0C80945A	Collar A	1				
46	0C80943A	Chuck Arm Spring	1				
47	CA80277A	Arm Bracket Ass'y	1				
48	0C80944A	Timing Arm Spring	1				
49	CA80276A	Timing Arm Ass'y	1				
50	0C80947A	Collar C	1				
51	CA80236A	Close End Switch P.C.B. Ass'y	1				
52	0C81158A	Switch Holder	1				
53	0C80969A	Rear Bracket	1				
54	0C81004A	Sheet	1				
55	0C80974A	Guide Rail R	1				
56	CA80353A	Disc Mechanism Sub Ass'y	1				
57	0C81002A	Guide Sheet	4				
58	0C80992A	Rear Bracket L	1				
59	0C81016A	Collar	4				
60	0C81022A	Damper B	4				
61	0C80773A	Mechanism Bracket L	2				
62	0C81020A	Mechanism Spring	4				
63	0C81018A	Damper Washer	4				
64	CA80282A	Front Bracket L Ass'y	1				
65	0C81017A	Shipping Screw	2				
66	CA80281A	Rear Bracket R Ass'y	1				
67	0C80774A	Mechanism Bracket R	1				
68	0C80993A	Front Bracket R	1				
L01	0C80963A	M2x1.8 @ Binding (Black Chromate)	2				
L02	0E00042A	E-Ring 1.5mm	1				
L03	0E00222A	E-Ring 2mm	6				
L04	0C80959A	M2x4 @ Pan	2				
L05	0E00029A	Washer 2x6x0.2	2				
L06	0E00985A	M3x6 @ Binding (Black Chromate)	11				
L07	0E03175A	M2.6x6 @ Pan (Black Chromate)	2				
L08	0C80954A	Plastic Rivet	2				
L09	0C80965A	BT 2.6x6 @ Nailtap Screw (Black Chromate)	5				
L10	0E00678A	M2.6x6 @ Countersunk (Black Chromate)	6				
L11	0E00967A	CS Stopper Ring 3mm	1				
L12	0C80990A	Wire Clamp	1				
L13	0C80955A	M2x8 @ Binding (Black Chromate)	1				

6.5. Rear Panel Ass'y (B02)

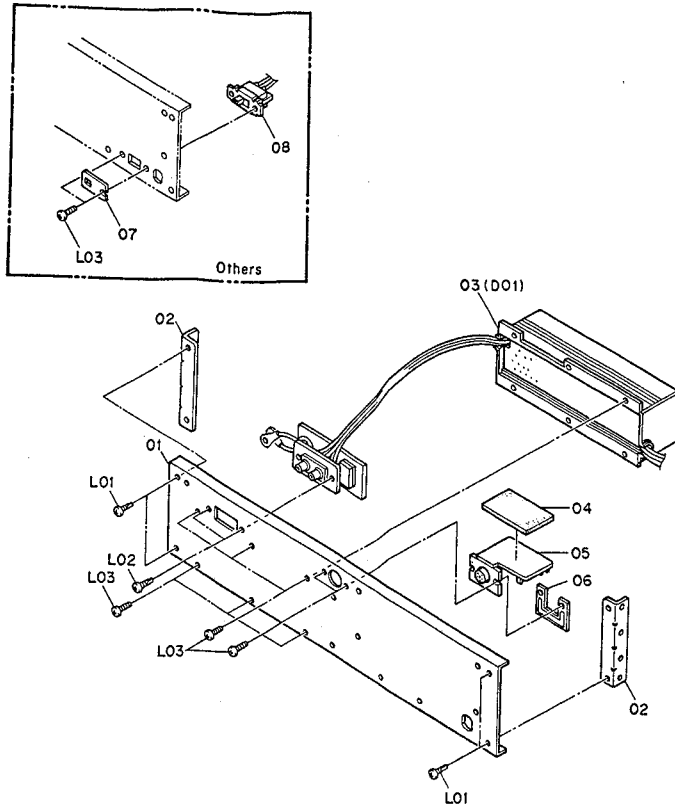

Fig. 6.5

6.6. Disc Mechanism Sub Ass'y (C01)

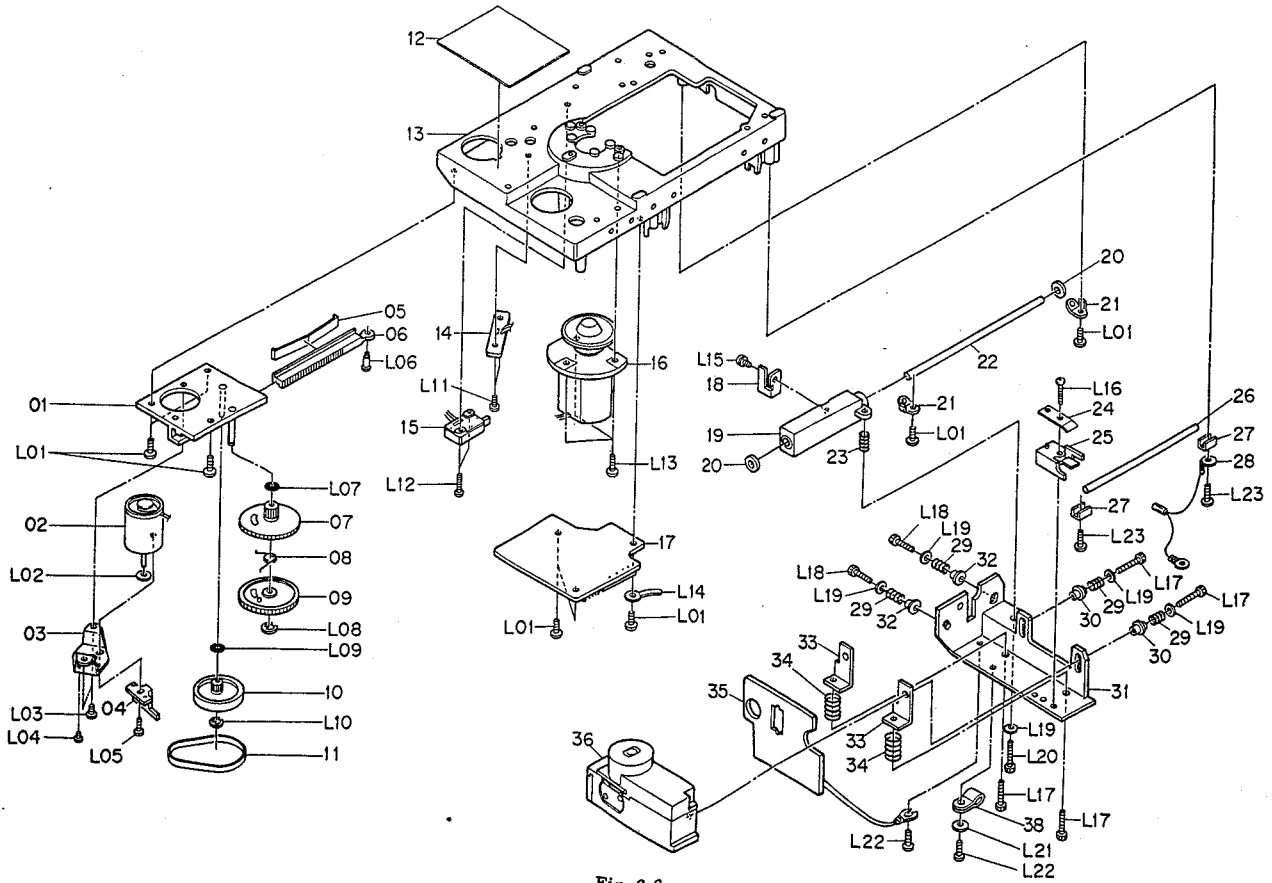

Fig. 6.6

6.7. Analog Processor Unit (D01)

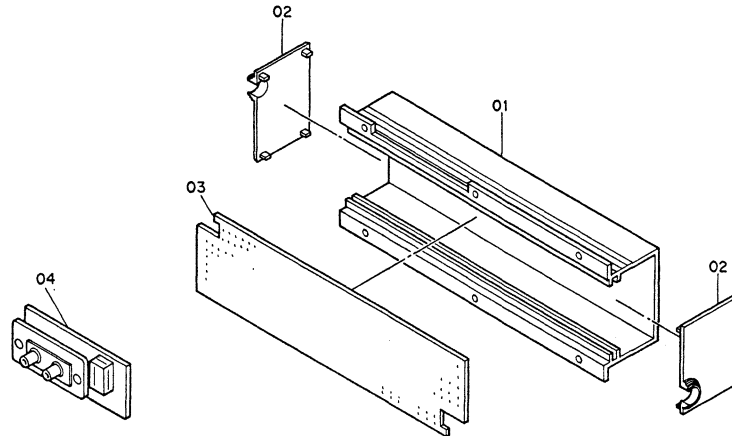

Fig. 6.7

Schematic Ref. No.	Part No.	Description	Q'ty	Schematic Ref. No.	Part No.	Description	Q'ty
B02	CA80299A	Rear Panel Ass'y OMS-5 (U.S.A., Canada & Australia)	1	35	CA80235A	RF Pre-Amp. P.C.B. Ass'y	1
	CA80302A	Rear Panel Ass'y OMS-5 (Others)	1	36	CA80255A	Laser Pickup Ass'y	1
	CA80300A	Rear Panel Ass'y OMS-5E	1	L01	OE03030A	M3x6 @ Binding (Nickel)	10
	CA80298A	Rear Panel Ass'y OMS-50 (Japan)	1	L02	—	Washer (Belongs to Feed Motor)	1
01	OC81351A	Rear Panel OMS-5 (U.S.A., Canada & Australia)	1	L03	OE00866A	M2.6x4 @ Binding	2
	OC81373A	Rear Panel OMS-5 (Others)	1	L04	OE00804A	M2x4 @ Binding (Black Chromate)	1
	OC81358A	Rear Panel OMS-5E	1	L05	OE00973A	M2x6 @ Binding	1
	OC81359A	Rear Panel OMS-50	1	L06	OC80777A	Pulley Support	1
02	OC80709A	Angle	2	L07	OC81126A	Mylar Washer 2.5mm	1
03	BA05515A	Analog Processor Unit	1	L08	OE00222A	E-Ring 2mm	1
04	OC81372A	Insulator	1	L09	OC81127A	Mylar Washer 2mm	1
05	CA80245A	Remote Control P.C.B. Ass'y	1	L10	OE00042A	E-Ring 1.5mm	1
06	OC80710A	DIN Jack Plate	1	L11	OC81340A	M2.6x6 @ Binding (Nickel)	2
07	OM03948A	Voltage Lock Plate OMS-7 (Others)	1	L12	OC81341A	M2.6x10 @ Pan (Nickel)	2
08	OB07092U	Voltage Selector OMS-7 (Others)	1	L13	OE03031A	M3x8 @ Binding (Nickel)	3
L01	OC81032A	BT 3x8 @ Nailtap Screw	4	L14	OC80704A	Wire Clamp	1
L02	OE00921A	BT 3x8 @ Binding (Black Chromate)	2	L15	OE03046A	M2.6x6 @ Pan (2A)	1
L03	OE00818A	M3x8 @ Binding (Black Chromate) (except OMS-7 (Others))	5	L16	OC81342A	M2.6x10 @ Pan	1
	OE00818A	M3x8 @ Binding (Black Chromate) OMS-7 (Others)	7	L17	OC81343A	Bolt M3x12 (Hex. Socket Head)	4
				L18	OC81344A	Bolt M3x10 (Hex. Socket Head)	2
				L19	OC81346A	Washer 3mm (3x8x0.5)	5
				L20	OC81345A	Bolt M3x16 (Hex. Socket Head)	1
				L21	OE00249A	Washer 2.6mm (Nickel)	1
			L22	OC81347A	M2.6x8 @ Binding (Nickel)	1	
			L23	OE03138A	M3x10 @ Binding (Nickel)	2	
C01	CA80353A	Disc Mechanism Sub Ass'y	1	D01	BA05515A	Analog Processor Unit	1
01	CA80261A	Gear Base Ass'y	1	01	OH04510A	Unit Case	1
02	OC80820A	Feed Motor	1	02	OH04511A	Side Cover	2
03	OC80770A	Motor Bracket	1	03	BA05494A	Analog Processor P.C.B. Ass'y	1
04	OC80792A	Belt Guide	1	04	BA05498A	Pin Jack P.C.B. Ass'y	1
05	OC80782A	Rack Spring	1				
06	OC80797A	Rack Gear	1				
07	OC80790A	Gear A	1				
08	OC80785A	Spring A	1				
09	OC80789A	Gear C	1				
10	OC80788A	Gear B	1				
11	OC80793A	Belt	1				
12	OC80794A	Sheet	1				
13	OC80769A	Chassis	1				
14	CA80242A	Photo Transistor P.C.B. Ass'y	1				
15	OC80926A	Microswitch	1				
16	OC80819A	Disc Motor	1				
17	CA80241A	Auto Power Control P.C.B. Ass'y	1				
18	OC80771A	Limiter Lever	1				
19	OC80767A	Bearing	1				
20	OC80795A	Damper	2				
21	OC80775A	Holder Plate	2				
22	OC80780A	Shaft A	1				
23	OC80784A	Spring B	1				
24	OC80776A	Plate Spring	1				
25	OC80791A	Slider	1				
26	OC80779A	Shaft B	1				
27	OC80781A	Shaft Holder	2				
28	CA80260A	Ground Wire Ass'y	1				
29	OC80783A	Spring C	4				
30	OC81338A	Bushing A	2				
31	OC80768A	Pickup Bracket	1				
32	OC80778A	Bushing B	2				
33	OC80772A	Adjuster Bracket	2				
34	OC80786A	Spring D	2				

7. MOUNTING DIAGRAMS AND PARTS LIST

- Notes: 1. Mounting diagram shows a dip side view of the printed circuit board.
 2. Diode is MA150, 1SS53, 1S1555, or 1SS176 unless otherwise specified.
 3. Abbreviation for part name:
 TR — Transistor, SiD — Silicon Diode, Varicap — Variable Capacitance Diode
 RK — Carbon Resistor, RM — Metal Film Resistor, RF — Fail Safe Type Resistor
 CE — Electrolytic Capacitor, CM — Mylar Capacitor, CC — Cement Capacitor,
 CT — Tantalum Capacitor, C — Mica Capacitor

7.1. Photo Transistor P.C.B. Ass'y

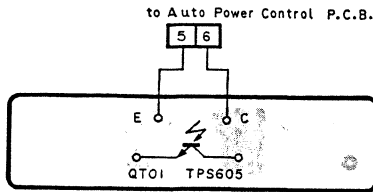

Fig. 7.1

7.6. Power Switch P.C.B. Ass'y

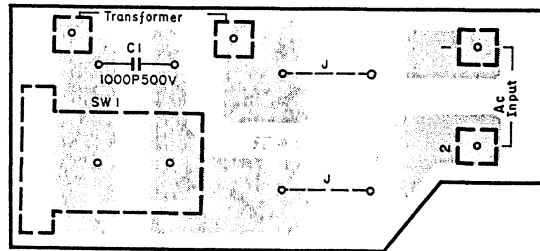

Fig. 7.6

7.2. Photo Diode P.C.B. Ass'y

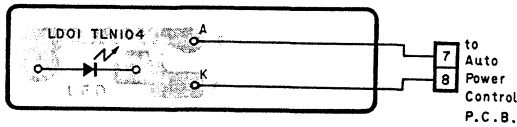

Fig. 7.2

7.7. Remote Control P.C.B. Ass'y

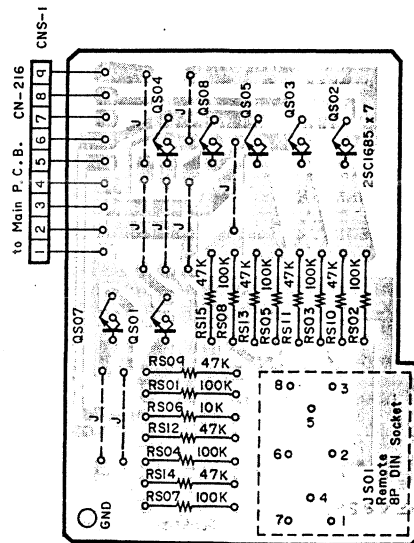

Fig. 7.7

7.3. Open End Switch P.C.B. Ass'y

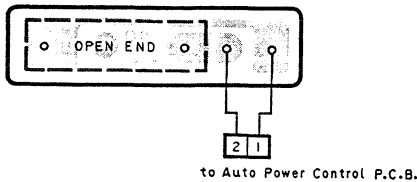

Fig. 7.3

7.4. Close End Switch P.C.B. Ass'y

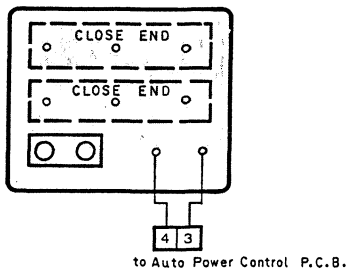

Fig. 7.4

7.5. Eject/Load Switch P.C.B. Ass'y

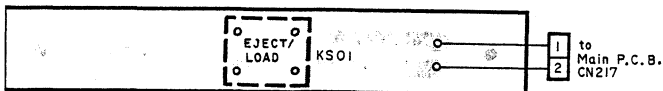

Fig. 7.5

7.8. Pin Jack P.C.B. Ass'y

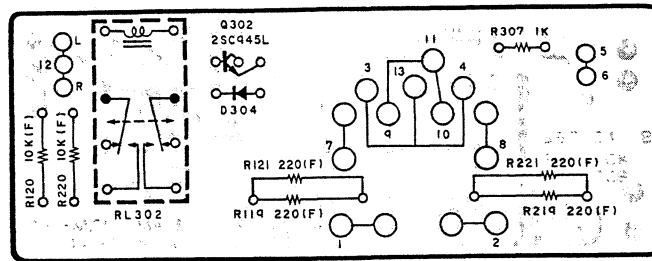

Fig. 7.8

7.9. FL Indicator P.C.B. Ass'y

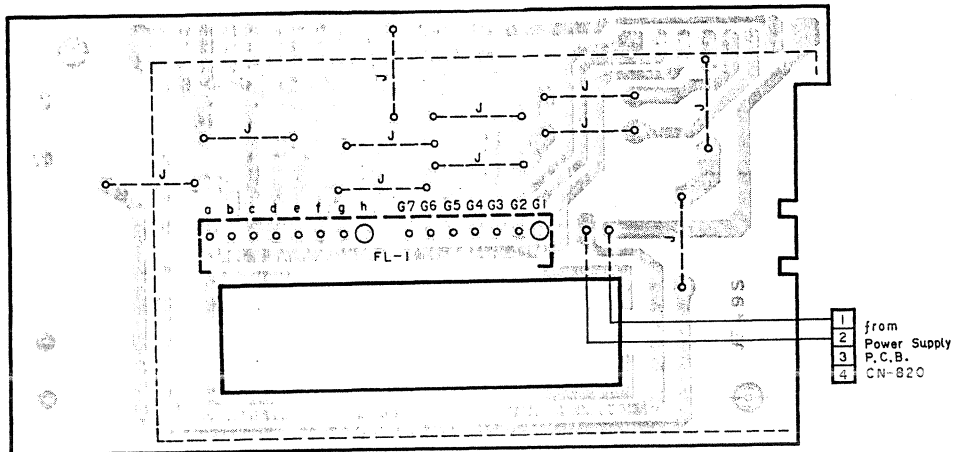

Fig. 7.9

Schematic Ref. No.	Part No.	Description	Schematic Ref. No.	Part No.	Description	Schematic Ref. No.	Part No.	Description
QT01	CA80242A	Photo Transistor P.C.B. Ass'y	C1	CA80240A	Power Switch P.C.B. Ass'y	FL1	CA80243A	FL Indicator P.C.B. Ass'y
	0C81201A	Photo Transistor P.C.B.		0C81202A	Power Switch P.C.B. CC 1000P 500V		0C81197A	FL Indicator P.C.B.
LD01	0C80758A	Photo TR TPS605	RS01-05 07,08	0C80914A	Push Switch SDL1P-B	0C80813A	FL Display	
	CA80234A	Photo Diode P.C.B. Ass'y		CA80245A	Remote Control P.C.B. Ass'y		CA80263A	8P Connector Cord Ass'y (1)
KS01	0C81200A	Photo Diode P.C.B.	RS01-05 07,08	0C81203A	Remote Control P.C.B. TR 2SC1685	CA80293A	7P Connector Cord Ass'y (1)	
	0C80759A	Photo Diode TLN104		0C80739A	TR 2SC1685		CA80265A	4P Connector Cord Ass'y (1)
KS01	CA80239A	Open End Switch P.C.B. Ass'y	RS06	0B01889A	RK 100K 1/4W J	0B01888A	RK 10K 1/4W J	
	0C81199A	Open End Switch P.C.B.		0B05641A	RK 47K 1/4W J		0B05641A	RK 47K 1/4W J
KS01	0C80911A	Microswitch (1)	JS01	0C80917A	8P DIN Socket	BA05498A	Pin Jack P.C.B. Ass'y	
	CA80291A	2P Connector Cord Ass'y (1)		0B60124B	Pin Jack P.C.B.		0B10025A	TR 2SC945L (P,K)
KS01	CA80236A	Close End Switch P.C.B. Ass'y	Q302	0B06398A	SiD 1SS176	0B22602A	RM 220 1/4W F	
	0C81180A	Close End Switch P.C.B.		R119,121	219,221	0B22594A	RM 10K 1/4W F	
KS01	0C80912A	Microswitch (1)	R120,220	0B09677A	RK 1K 1/6W J	0B90038A	DS Relay 12V	
	CA80237A	Eject/Load Switch P.C.B. Ass'y		R307	0B82341B	XH Connector 3P 700mm (1)	0B81282A	Pin Jack 2P (1)
KS01	0C81195A	Eject/Load Switch P.C.B.	RL302					
	0C80913A	Key Switch B3F-1000						

7.10. Auto Power Control P.C.B. Ass'y

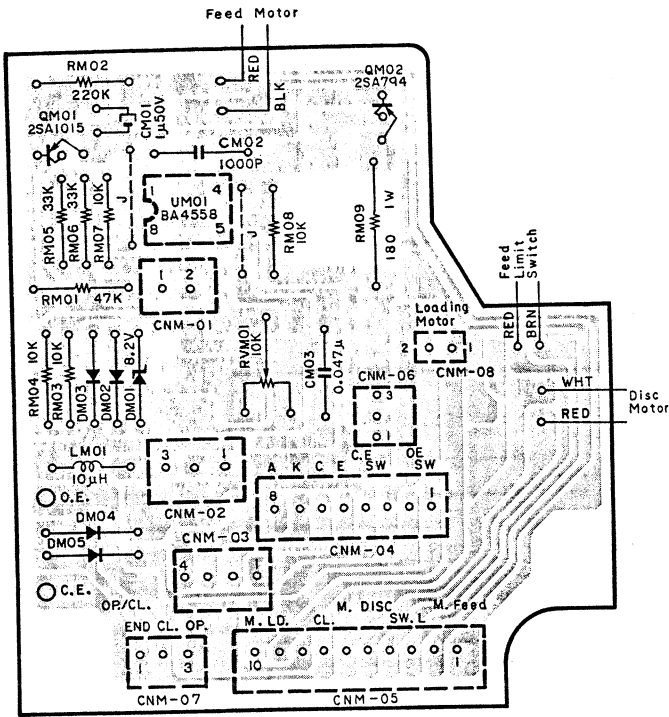

Fig. 7.10

Schematic Ref. No.	Part No.	Description
	CA80241A	Auto Power Control P.C.B. Ass'y
	0C81174A	Auto Power Control P.C.B.
UM01	0C80923A	IC BA4558
QM01	0C80743A	TR 2SA1015
QM02	0C80756A	TR 2SA794
DM01	0C80932A	ZD 8.2V MA1082
DM02,03	0C80877A	SiD MA150
04,05		
LM01	0C80922A	RF Coil 10μH
RVM01	0C80887A	Potentiometer 10K
RM01	0B05641A	RK 47K 1/4W J
RM02	0B05625A	RK 220K 1/4W J
RM03,04	0B01888A	RK 10K 1/4W J
07,08		
RM05,06	0B05509A	RK 33K 1/4W J
RM09	0C80924A	RM 180 1W J
CM01	0B40112A	CE 1μ 50V
CM02	0C80930A	CC 1000P 50V M
CM03	0B05797A	CC 0.047μ 50V Z
CNM06	0C80928A	3P Connector Terminal
CNM07	0C80929A	3P Connector Terminal
CNM08	0C80927A	2P Connector Terminal
	CA80272A	1P Connector Cord Ass'y (1)
	CA80273A	2P Connector Cord Ass'y (1)
	CA80274A	4P Connector Cord Ass'y (1)
	CA80275A	8P Connector Cord Ass'y (1)
	0C80919A	Ribbon Wire (1)

7.11. RF Pre-Amp. P.C.B. Ass'y

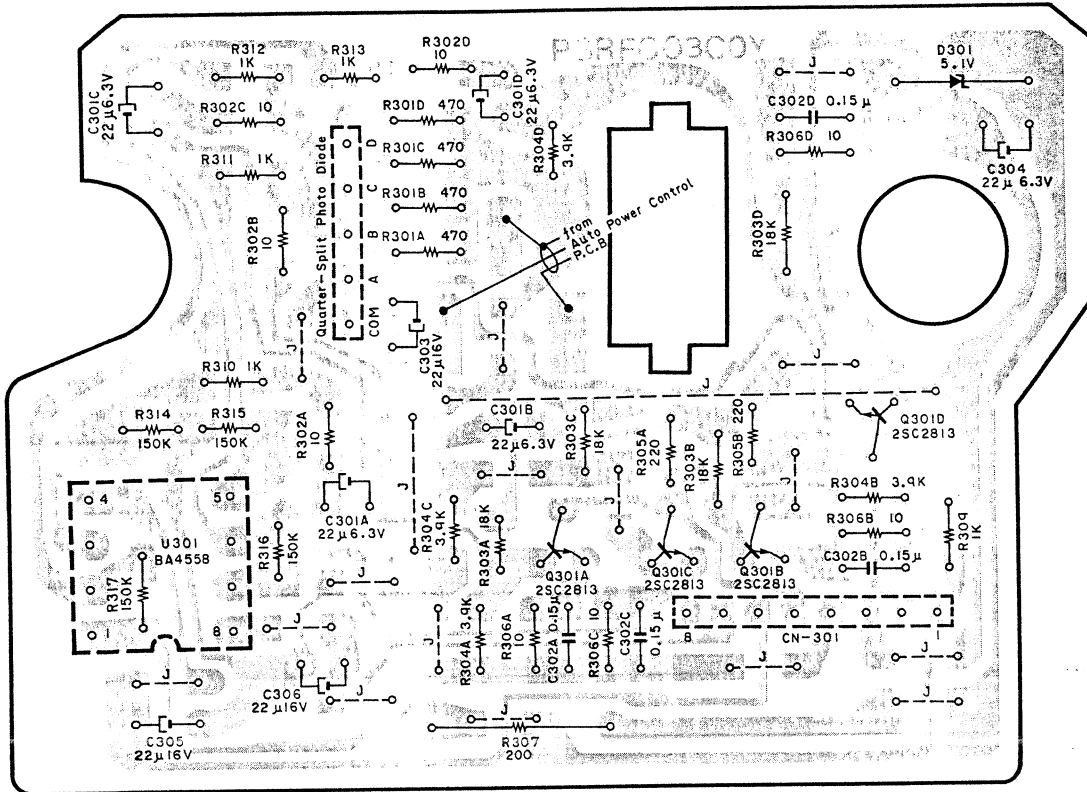

Fig. 7.11

Schematic Ref. No.	Part No.	Description	Schematic Ref. No.	Part No.	Description
	CA80235A	RF Pre-Amp. P.C.B. Ass'y	C301A 301B 301C 301D,304	0B40128A	CE 22μ 6.3V
U301	OC81204A	RF Pre-Amp. P.C.B. IC BA4558	C302A 302B 302C 302D	0C81176A	CC 0.15μ 50V K (Chip)
Q301A 301B 301C 301D	OC81067A	TR 2SC2813 (Chip)	C303,305 306	0B40075A	CE 22μ 16V
D301	OC80871A	ZD 5.1V RD5.1EB1	CN301	0C80875A	8P Connector Terminal Lug Ass'y (1)
R301A 301B 301C 301D	OB23065A	RK 470 1/8W J (Chip)		CA80294A	
R302A 302B 302C 302D 306A 306B 306C 306D	OB23025A	RK 10 1/8W J (Chip)			
R303A 303B 303C 303D	OB23103A	RK 18K 1/8W J (Chip)			
R304A 304B 304C 304D	OB23087A	RK 3.9K 1/8W J (Chip)			
R305A 305B	OB23057A	RK 220 1/8W J (Chip)			
R307	OB09660A	RK 200 1/4W J			
R309,310 311,312 313	OB23073A	RK 1K 1/8W J (Chip)			
R314,315 316,317	OB23125A	RK 150K 1/8W J (Chip)			

7.12. Power Supply P.C.B. Ass'y

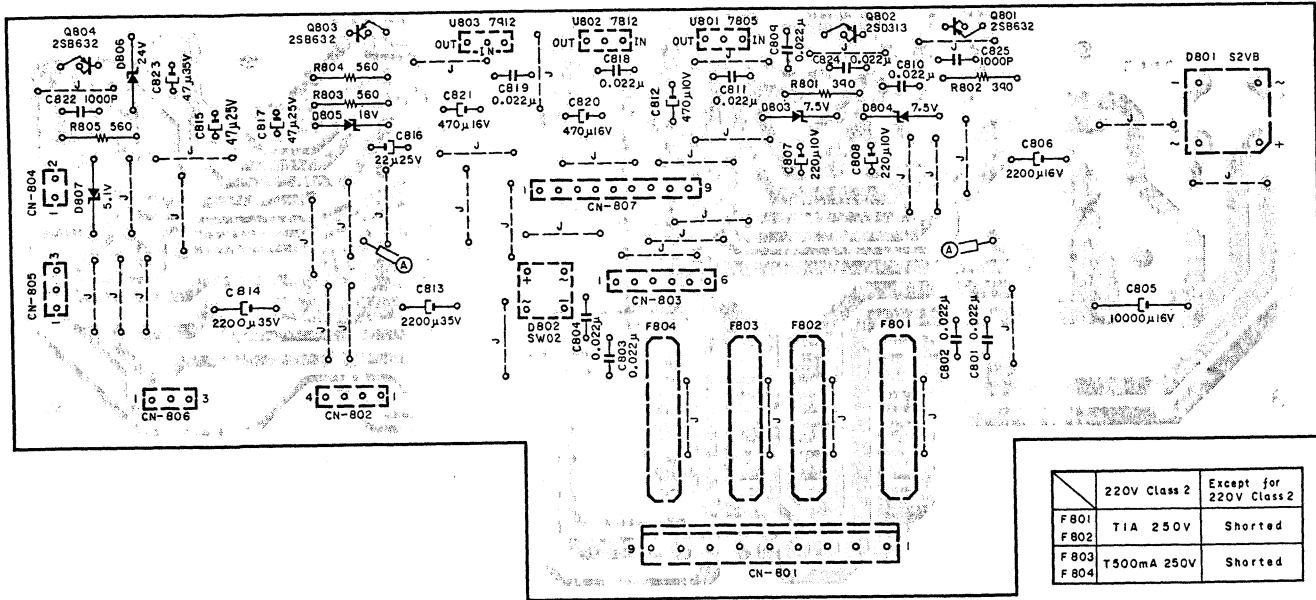

Fig. 7.12

Schematic Ref. No.	Part No.	Description	Schematic Ref. No.	Part No.	Description	Schematic Ref. No.	Part No.	Description
	CA80232A	Power Supply P.C.B. Ass'y		CA80304A	Control Switch P.C.B. Ass'y	R116,216 R117,118 R119,218	OB22589A OB22591A	RM 100K 1/2W F RM 1K 1/4W F
U801	OC81414A	Power Supply P.C.B. IC	LDK02.03	OC81181A	Control Switch P.C.B. LED 1301	R301,306 R302,303 R304,305	OB09677A OB09725A OB09741A	RK 1K 1/6W J RK 100K 1/6W J RK 470K 1/6W J
U802	OB11011A	IC	04	OC80755A	LED 1301	C101,201 C102,202	OB41195A OB41194A	CM 4700P 100V G CM 0.01μ 100V K
U803	OB11057A	IC	RK09.10	OB01706A	RK 47 1/4W J	C103,203 C104,204	OB09247A OB09903A	C 220P 50V J CE 2.2μ 50V (KS)
Q801,803 804	OC80738A	TR	11	CA80270A	9P Connector Cord Ass'y (1)		OB41196A	CM 470P 160V J
Q802	OC80737A	TR		CA80268A	2P Connector Cord Ass'y (1)	C105,205 C106,206	OB41198A OB41197A	CM 1800P 160V J CM 1200P 160V J
D801	OC80849A	Diode Bridge S2VB		OC80908A	Key Switch B3F-1022 (1)	C107,207 C108,208	OB41199A OB41199A	CM 1200P 160V J CM 0.047μ 100V K
D802	OC80850A	Diode Bridge SW02		OC80907A	Key Switch B3F-1020 (8)	C109,209	OB41192A	CM 1μ 100V K
D803,804	OC80863A	ZD 7.5V MA1075		OC80909A	LED Holder S (1)	C110,111	OB41193A	CM 0.22μ 100V K
D805	OC81068A	ZD 18V MA1180		OC80910A	LED Holder W (1)	210,211		
D806	OC80864A	ZD 24V MA1240		OC81207A	Shield Case (1)	C112,113 212,213	OB41200A	C 47P 500V J
D807	OC80862A	ZD 5.1V MA1051						
R801,802	OB05691A	RK 390 1/4W J		BA05494A	Analog Processor P.C.B. Ass'y	RL301	OB90038A	DS Relay 12V
R803,804	OB05755A	RK 560 1/4W J					OB82338B	XH Connector 3P 480mm (1)
805				OB60122A	Analog Processor P.C.B. IC LF353N		OB82339B	EH Connector 4P 450mm (1)
C801,802	OB09291A	CC 0.022μ 50V Z		OB11155A			OB82340A	XH Connector 3P 570mm (1)
803,804				OB06299A	TR 2SC2878		OB82116B	Ribbon Cable 2P 160mm (2)
809,810				OB06142A	TR 2SC2240 (BL)		OB82345A	Ribbon Cable 2P 120mm (2)
811,818				OB10050A	TR 2SA970 (BL)			
819,824				OB10025A	TR 2SC945L (P.K)			
C805	OB40233A	CE 10000μ 16V	IC101.201	OB12128A	ZD 10V RD10JSB2			
C806	OB40083A	CE 2200μ 16V	301	OB06398A	SiD 1S5176			
C807,808	OB05899A	CE 220μ 10V	Q101,201	OB22585A	RM 887 1W F			
C812	OB40067A	CE 470μ 10V	Q102,202	OB22588A	RM 23.7K 1/2W F			
C813,814	OB40109A	CE 2200μ 35V	Q103,203	OB22592A	RM 2.21K 1/4W F			
C815,817	OB40036A	CE 47μ 25V	Q301	OB22593A	RM 8.25K 1/4W F			
C816	OB40088A	CE 22μ 25V	ZD101,102	OB22590A	RM 1M 1/2W G			
C820,821	OB40081A	CE 470μ 16V	201,202	OB22587A	RM 8.25K 1/2W F			
C822,825	OB09288A	CC 1000P 50V K	D301,302	OB22595A	RM 51.1K 1/4W F			
C823	OB40103A	CE 47μ 35V		OB22596A	RM 100K 1/4W F			
CN801	OC80859A	9P Connector Terminal	R101,201	OB22597A	RM 300K 1/4W G			
CN802	OC80858A	4P Connector Terminal	R102,108					
CN803	CA80292A	6P Connector Cord Ass'y	R103,203					
CN804	OC80856A	2P Connector Terminal	R104,204					
CN805,806	OC80857A	3P Connector Terminal	R105,106					
CN807	CA80267A	9P Connector Cord Ass'y	205,206					
	OC80847A	Heat Sink A (1)	R107,207					
	OC80848A	Heat Sink B (1)	R109,110					
	OC80854A	Insulator (1)	111,209					
	OB08347U	Fuse T1A 250V (220V Class 2)	210,211					
	OB08457A	Fuse T500mA 250V (220V Class 2)	112,212 R113,114 115,213 214,215					

7.13. Control Switch P.C.B. Ass'y

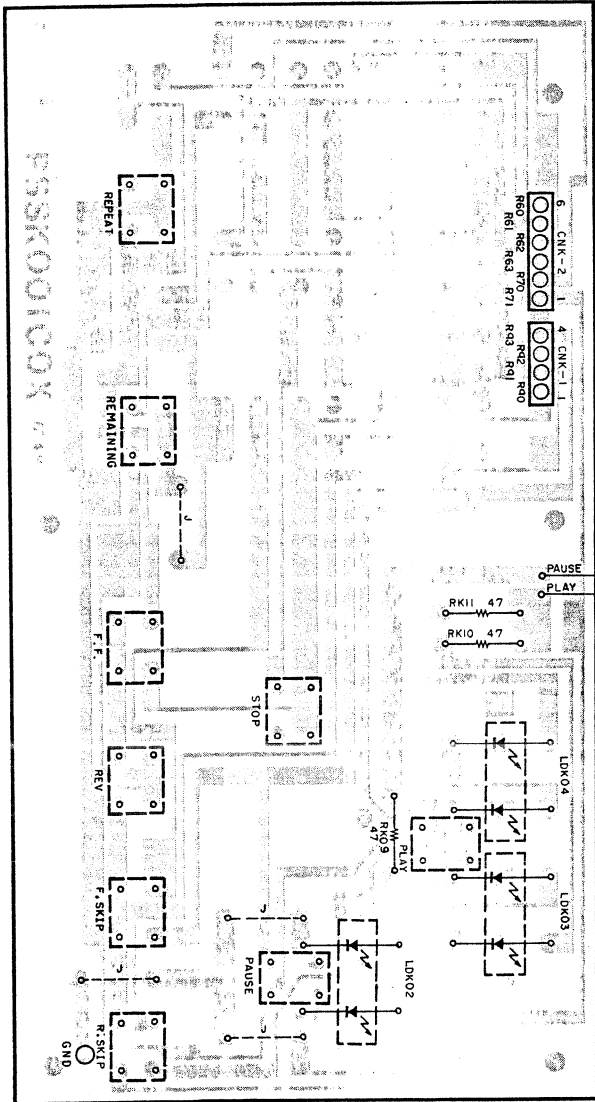

Fig. 7.13

7.14. Analog Processor P.C.B. Ass'y

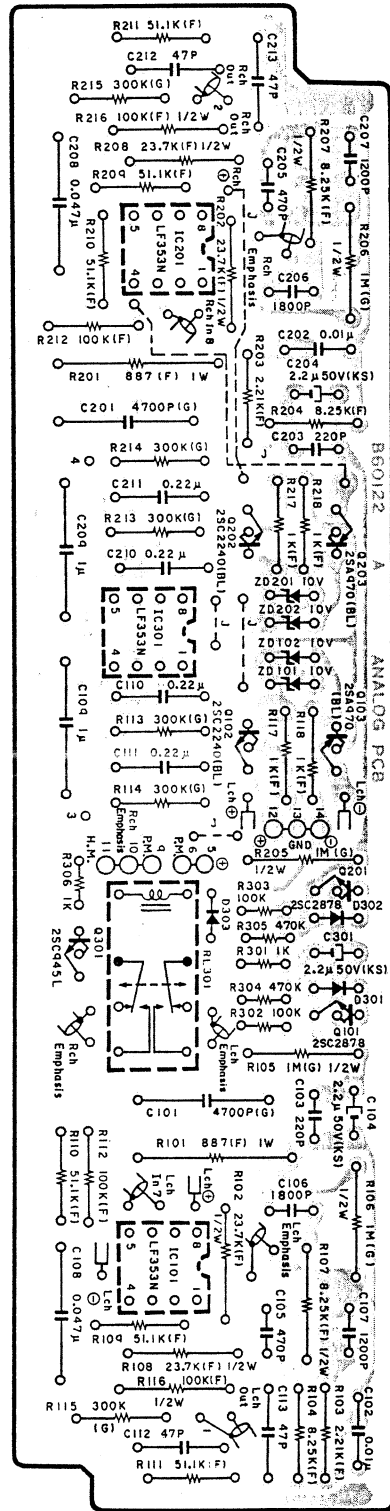

Fig. 7.14

7.15. D/A Converter P.C.B. Ass'y

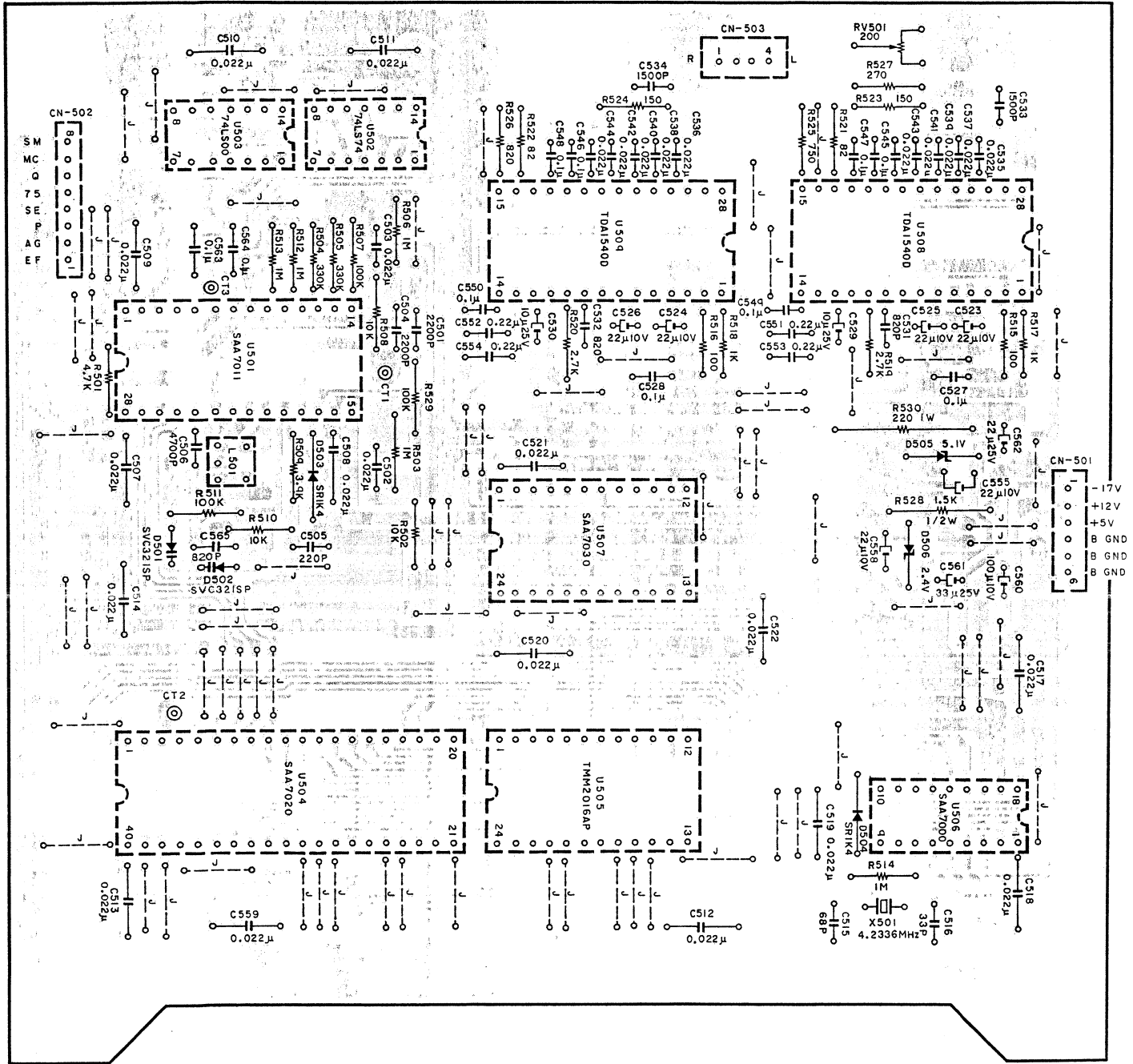

Fig. 7.15

Schematic Ref. No.	Part No.	Description
	CA80233A	D/A Converter P.C.B. Ass'y
	0C81194A	D/A Converter P.C.B.
U501	0C80727A	IC SAA7011
U502	0C80828A	IC 74LS74
U503	0C80827A	IC 74LS00
U504	0C80728A	IC SAA7020
U505	0C80749A	IC TMM2016P-2
U506	0C80730A	IC SAA7000
U507	0C80729A	IC SAA7030
U508,509	0C80731A	IC TDA1540D
D501,502	0C80823A	Varicap SVC321SP
D503,504	0C80824A	SiD SR1K4
D505	0C80826A	ZD 5.1V
D506	0C80825A	ZD 2.4V
X501	0C80834A	Crystal 4.2336 MHz
L501	0C80833A	VCO Coil
RV501	0C80832A	Potentiometer 200
R501	OB01846A	RK 4.7K 1/4W J
R502,508 510	OB01888A	RK 10K 1/4W J
R503,506 512,513 514	OB05776A	RK 1M 1/4W J
R504,505	OB05627A	RK 330K 1/4W J
R507,511 529	OB01889A	RK 100K 1/4W J
R509	OB05675A	RK 3.9K 1/4W J
R515,516	OB01679A	RK 100 1/4W J
R517,518	OB01857A	RK 1K 1/4W J
R519,520	OB05629A	RK 2.7K 1/4W J
R521,522	OB05631A	RK 82 1/4W J
R523,524	OB05795A	RK 150 1/4W J
R525	OB09924A	RK 750 1/4W J
R526	OB01680A	RK 820 1/4W J
R527	OB05645A	RK 270 1/4W J
R528	0C80830A	RM 1.5K 1/2W J
R530	OB80831A	RM 220 1W J
C501,504	OB04060A	CM 2200P 50V K
C502,503	OB41098A	CM 0.022μ 63V
C505	OB09247A	CM 220P 50V J
C506	OB05652A	CM 4700P 50V J
C507-514 517-522 559	0C80805A	CC 0.022μ 50V M (15)
C515	0C80838A	CC 68P 50V J
C516	0C81189A	CC 33P 50V J
C523,524 525,526	0C81178A	CE 22μ 10V
C527,528 545-550 563,564	OB41537A	CM 0.1μ 100V J (10)
C529,530	0C80802A	CE 10μ 25V
C531,532	OB09993A	CM 820P 50V J
C533,534	OB05653A	CM 1500P 50V J
C535-544	OB41098A	CM 0.022μ 100V J (10)
C551,552 553,554	OB41176A	CM 0.22μ 63V J
C555,558	OB40159A	CE 22μ 10V
C560	OB40063A	CE 100μ 10V
C561	OB40076A	CE 33μ 25V
C562	OB40088A	CE 22μ 25V
C565	0C80804A	CC 820P 50V K
CN501	0C80836A	6P Connector Terminal
CN502	0C80837A	8P Connector Terminal
CN503	0C81134A	4P Connector Terminal
CT1,2,3	0C80829A	Test Pin

Schematic Ref. No.	Part No.	Description	Schematic Ref. No.	Part No.	Description	Schematic Ref. No.	Part No.	Description
	CA80303A	Main P.C.B. Ass'y	R129,165	OB05641A	RK 47K 1/4W J	C102,103	OB40278A	CT 1μ 16V
			171,179			C106,107	OC80805A	CC 0.022μ 50V M
U101,102	OC81196A	Main P.C.B.	212,242			108,111		
103	OC80740A	IC TA7302P	260,275			112,114		
U104	OC80880A	IC SN74LS04N	277,278			122,124		
U105,106	OC80923A	IC BA4558	280,304	OB01846A	RK 4.7K 1/4W J	132,143		
107,108			R130,191			148,164		
110			194,216			165,168		
U109	OC80732A	IC BA547	239,305			171,172		
U111	OC80733A	IC BA6208	311			176,178		
U112	OC80734A	IC HD4053BP	R138,166	OB09388A	RK 5.1K 1/4W J	180,181		
U113	OB06178A	IC μPD4011BC	R139,140	OB01888A	RK 10K 1/4W J	182,183		
U114	OB06215A	IC TC4049BP	149,150			187,189		
U115	OB06214A	IC μPD4071BC	186,211			191,198		
U116	OC80736A	IC HMCS404C	214,221			207,209		
U117	OC80735A	IC HMCS402C	223,261			213		
Q101,102	OC80741A	TR 2SC1675	262,265			C109,115	OB40112A	CE 1μ 50V
103,104			266,296			130,184		
Q105,106	OC80739A	TR 2SC1685	309,310			204		
113,114			R141,142	OB01889A	RK 100K 1/4W J	C116,117	OC81182A	CC 0.015μ 50V M
121,122			222,225			C120	OC81184A	CC 100P 50V J
Q107,109	OC80742A	TR 2SC1815	228,273			C121	OB40023A	CE 0.22μ 50V
131,302			276,282			C125,129	OC81183A	CC 0.01μ 50V M
Q108,110	OC80743A	TR 2SA1015	283,284			177,217		
128,303			314			C126,131	OC81186A	CC 220P 50V K
Q111,112	OC80744A	FET 2SK136	R143,144	OB01679A	RK 100 1/4W J	C127,128	OC81192A	CC 47P 50V J
Q115,118	OC80745A	FET 2SK246	175,180			133,134		
120			227,254			C137,138	OC81190A	CC 4.7μ 50V K
Q116	OC80750A	TR 2SC3422	R151,153	OB09509A	RK 20K 1/4W J	C139,140	OC81185A	CC 1500P 50V M
Q117	OC80751A	TR 2SA1359	241	OB05621A	RK 120K 1/4W J	C141,142	OB40165A	CE 47μ 16V
Q119,123	OC80747A	TR 2SA564	R162,164	OB01683A	RK 15K 1/4W J	C145,202	OB41094A	CM 0.01μ 100V J
126,129			230,231			203		
130			R163	OB09369A	RK 62K 1/4W J	C146	OB04060A	CM 2200P 50V K
Q124	OC80746A	TR 2SC1449	R167	OB09307A	RK 4.3K 1/4W J	C147	OB09189A	CM 2700P 50V J
Q125	OC80738A	TR 2SB632	R169,178	OB01682A	RK 6.8K 1/4W J	C149	OB41373A	CM 0.068μ 100V J
Q127	OC80748A	TR 2SC1384	R173	OB05694A	RK 9.1K 1/4W J	C150	OC81188A	CC 3300P 50V M
D101-114	OC80877A	SiD MA150 (42)	R174	OB05626A	RK 150K 1/4W J	C161,190	OC80930A	CC 1000P 50V M
116-129			R176	OB01854A	RK 39K 1/4W J	212		
134			R177,229	OB09183A	RK 7.5K 1/4W J	C162	OC81193A	CC 680P 50V K
136-146			294			C163	OC81184A	CC 100P 50V J
305,306			R181	OB05784A	RK 560K 1/4W J	C166,167	OB40063A	CE 100μ 10V
D115,133	OC80902A	ZD 4.7V MA1047	R182	OB09320A	RK 820K 1/4W J	C170	OC81191A	CC 470P 50V K
135			R183	OB05627A	RK 330K 1/4W J	C173	OB40199A	CE 1μ 50V (BP)
D131,132	OC80824A	SiD SR1K4	R184,213	OB05776A	RK 1M 1/4W J	C174,210	OB40240A	CE 0.47μ 50V (BP)
D147	OC80863A	ZD 7.5V MA1075	279,293			C175	OB40246A	CE 10μ 16V (BP)
CX101	OC81179A	Crystal 4MHz	R187,188	OB09392A	RK 200K 1/4W J	C179,199	OC81205A	CE 0.1μ 50V (LN)
T101,102	OC80876A	Pulse Transformer	R189	OB09560A	RK 18K 1/4W J	C192	OB40020A	CE 10μ 35V
RV101,106	OC80887A	Potentiometer 10K	R190	OB05626A	RK 150K 1/4W J	C193	OB40013A	CE 3.3μ 25V
107,108			R192,193	OB05967A	RK 300 1/4W J	C194,195	OC81189A	CC 33P 50V J
RV102,105	OC80888A	Potentiometer 2K	233,234			C200	OB41175A	CM 0.15μ 63V
RV103	OC80886A	Potentiometer 1K	R195,196	OB05695A	RK 1 1/4W J	C201	OB05659A	CM 5600P 100V
RV104	OC80889A	Potentiometer 5K	312,313			C205	OB40243A	CE 4.7μ 25V (BP)
RV109,110	OC80890A	Potentiometer 50K	R197,198	OB09753A	RK 4.7 1/4W J	C208	OC81187A	CC 2700P 50V M
R101	OB05936A	RK 10 1/4W J	R199,251	OB05698A	RK 1.5K 1/4W J	C211	OB40238A	CE 0.22μ 50V (BP)
R102,104	OB05622A	RK 2.2K 1/4W J	R215	OB09924A	RK 750 1/4W J	C216	OB40008A	CE 47μ 10V
145,147			R217,220	OB09548A	RK 24K 1/4W J	C218	OB40009A	CE 10μ 16V
148,185			R219,224	OB05876A	RK 51K 1/4W J	CN201,210	OC80837A	8P Connector
218,226			285			211	Terminal	
R103,132	OB05576A	RK 470 1/4W J	R232,235	OB05675A	RK 3.9K 1/4W J	CN202,216	OC81173A	9P Connector
133,136			R236	OB05575A	RK 560 1/4W J	CN203,208	OC80856A	Terminal
137			R237,238	OC81131A	RK 0.5 1/4W J	209,217	2P Connector	
R105,106	OC81130A	RK 1.1K 1/4W J	R243	OB05640A	RK 180K 1/4W J	CN204,207	OC80857A	Terminal
R107,108	OB05509A	RK 33K 1/4W J	R246	OB09826A	RK 3K 1/4W J		OC80857A	3P Connector
R109,110	OB09075A	RK 30K 1/4W J	R247	OB01887A	RK 5.6K 1/4W J	CN205	OC80836A	Terminal
240,250			R248	OB09556A	RK 3.6K 1/4W J	CN206,214	OC80858A	6P Connector
308			R249,256	OB05625A	RK 220K 1/4W J		Terminal	
R111,112	OB05795A	RK 150 1/4W J	258,267			CN212	OC80858A	4P Connector
123,125			268,270			CN213	OC81172A	Terminal
R113,114	OB05645A	RK 270 1/4W J	271,272			CN215	OC81173A	7P Connector
115,116			306			CN217	OC81413A	Terminal
R117	OB09272A	RK 910 1/4W J	R252	OB01684A	RK 470K 1/4W J		OC81133A	5P Connector
R118,119	OB01857A	RK 1K 1/4W J	R255,257	OB09925A	RK 2.2 1/4W J		Terminal	
122,128			R263,292	OB05688A	RK 390 1/4W J		11P Connector	
134,135			R269	OB05615A	RK 22K 1/4W J		Terminal	
146,170			R274	OB09072A	RK 110K 1/4W J		2P Connector	
172,200			R281	OC81132A	RK 91 1/4W J		Terminal	
244,291			R316,317	OB09784A	RK 3.3M 1/4W J			
295,315			C101,104	OB40009A	CE 10μ 16V			
R120,121	OB01681A	RK 3.3K 1/4W J	105,110					
290			113,118					
R124	OB05868A	RK 680K 1/4W J	119,123					
R126,152	OB09301A	RK 2K 1/4W J	135,136					
154			151,169					
R127,131	OB01706A	RK 47 1/4W J	185,186					
253,259			196,197					
			206,214					
			215,303					

7.16. Main P.C.B. Ass'y

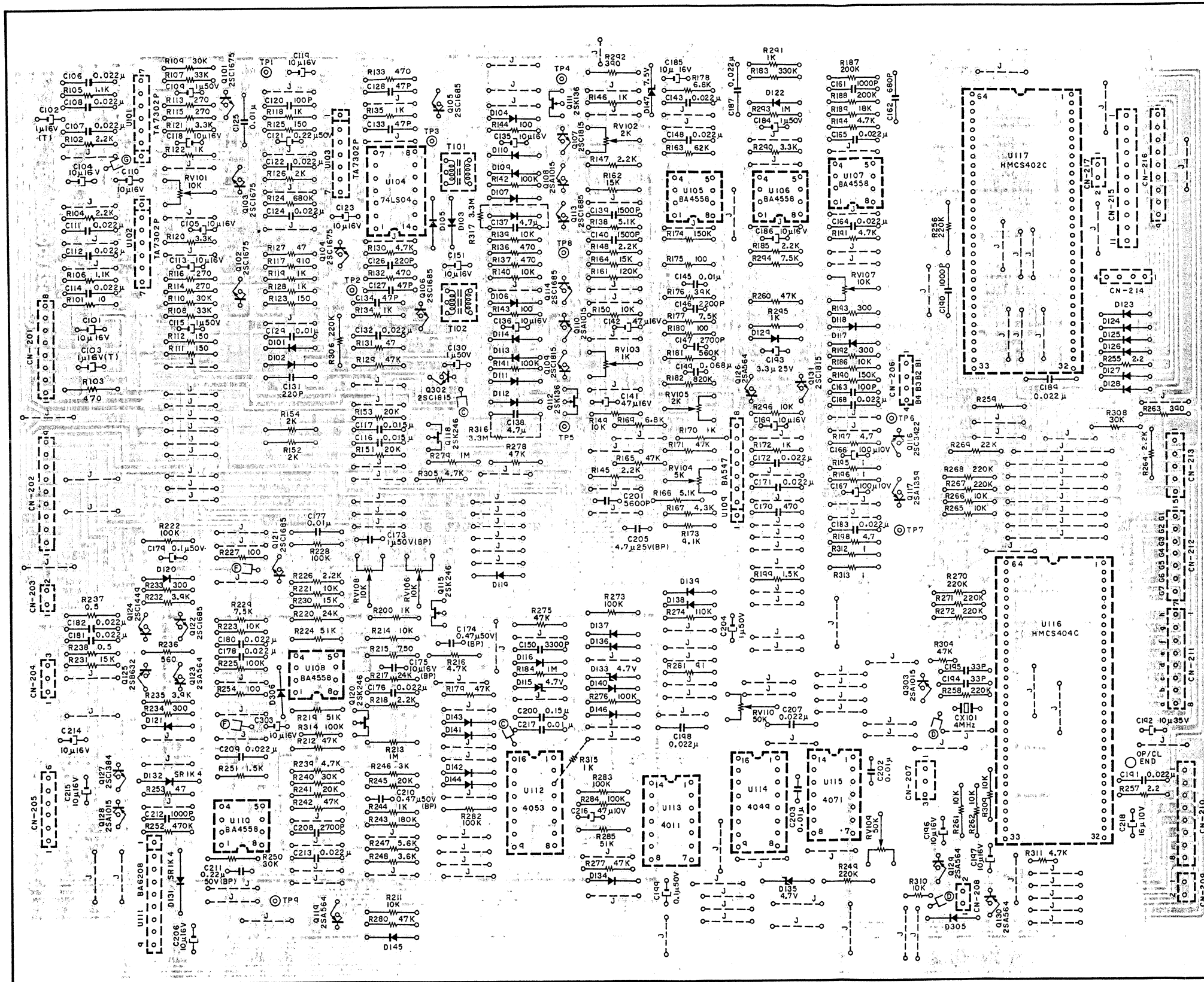

Fig. 7.16

8. SCHEMATIC DIAGRAM

8.1. IC Block Diagrams and Descriptions

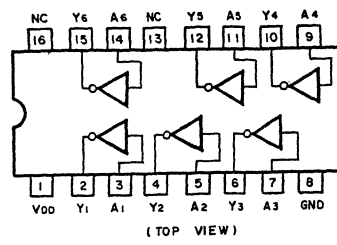

Fig. 8.1.1 Inverter C-MOS IC TC4049BP

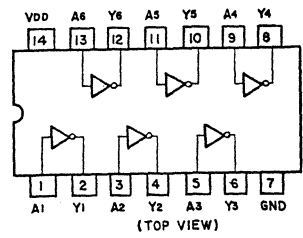

Fig. 8.1.2 Inverter TTL IC 74LS04

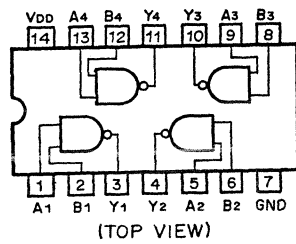

Fig. 8.1.3 NAND Gate C-MOS IC μPD4011BC

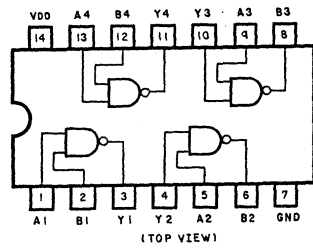

Fig. 8.1.4 NAND Gate TTL IC 74LS00

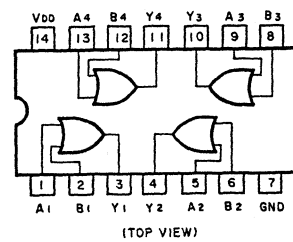

Fig. 8.1.5 OR Gate C-MOS IC μPD4071BC

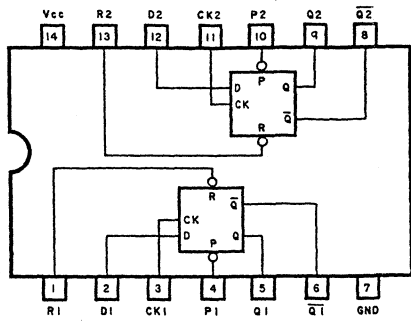

Fig. 8.1.6 D-Type Flip-Flop TTL IC 74LS74

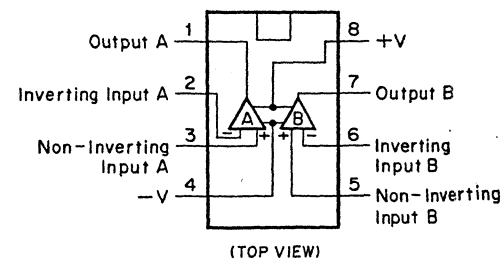

Fig. 8.1.7 Operational Amp. IC BA4558, LF353N

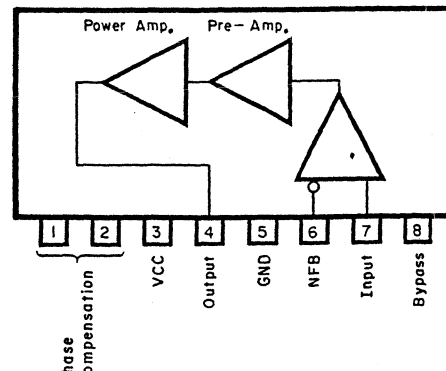

Fig. 8.1.18 D/A Converter IC TDA1540D

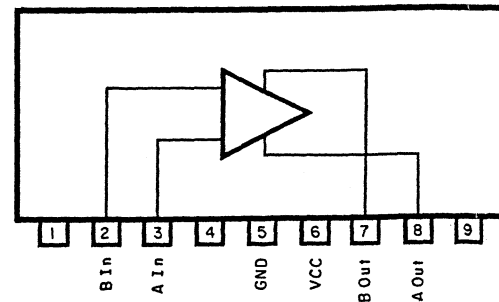

Fig. 8.1.9 Motor Driver BA6208

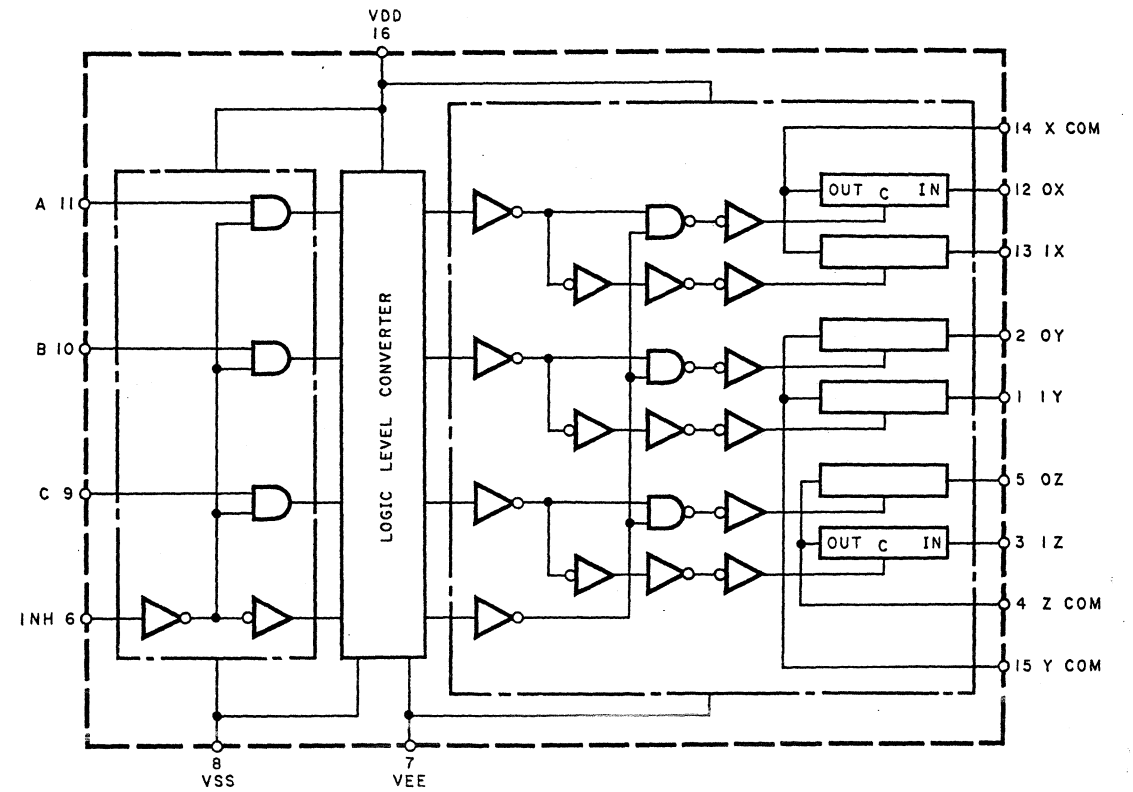

Fig. 8.1.10 Analog Switch HD4053BP

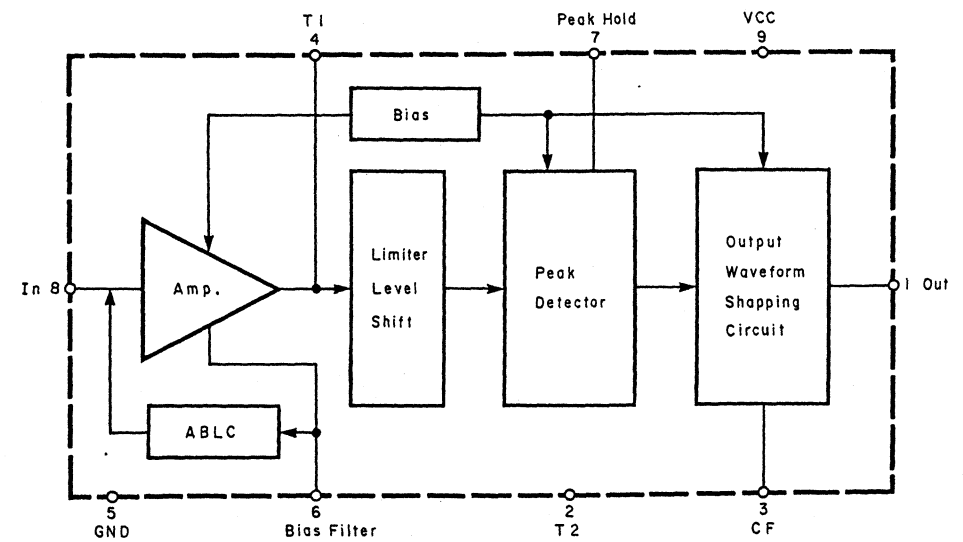

Fig. 8.1.11 Pre-Amp. IC μPC1474HA

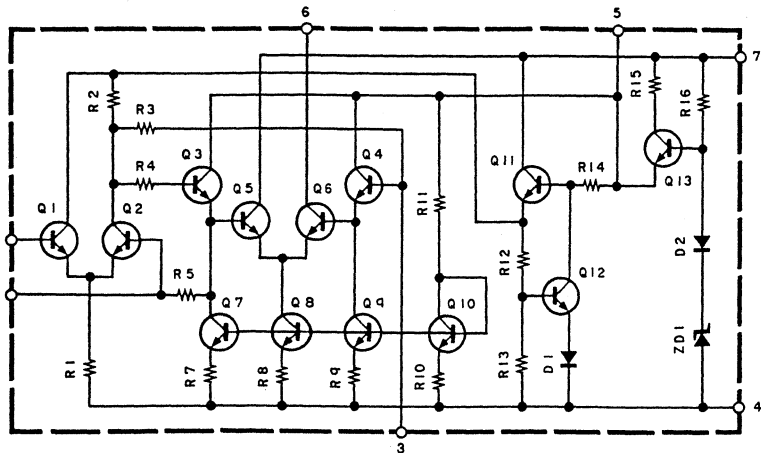

Fig. 8.1.12 RF IF Amp. TA7302P

OSC1, OSC2: Crystal Input for Internal Oscillator
 Test: Test
 Reset: Reset
 INT0, INT1: Interrupt
 SCK, SI, SO: Serial Interface
 D0-15: Bidirectional Ports
 R00-03, 60-63, 70-73, 80-83: Output Ports
 R10-13, 20-23, 30-33, 40-43, 50-53: Bidirectional Ports
 R90-93, RA0, RA1: Input Ports

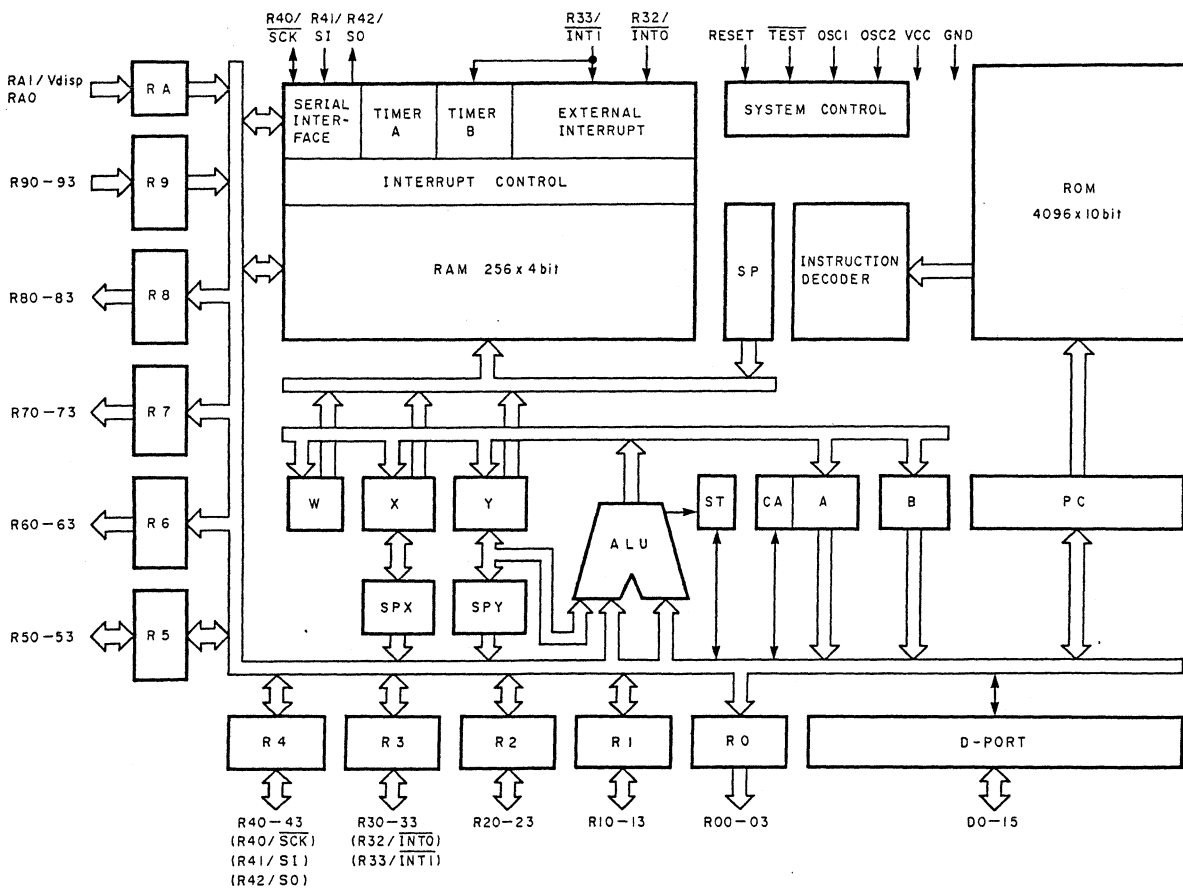
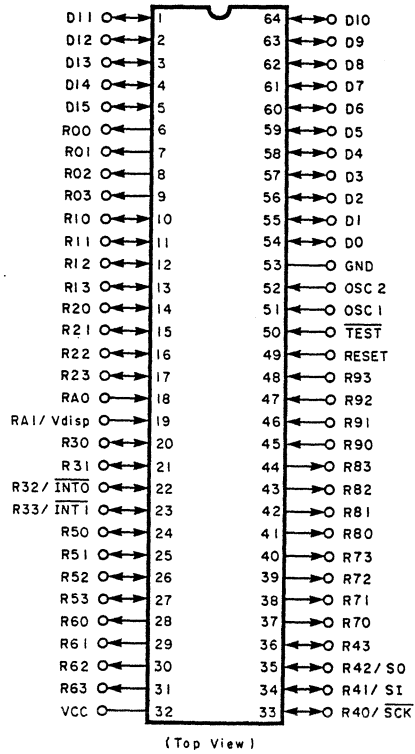

Fig. 8.1.13 Micro Processor HMCS404C/402C

Description of Demodulator IC U501 (SAA7011)
(See Figs. 8.1.14 - 8.1.16.)

Pin Description of Demodulator IC:

Pin No.	Signal Name	In/Out	Description
1	VBB	In	-2.5 V. Back bias supply.
2	SDATA	Out	Push-pull output for subcoding data. An 8 bit burst of data (including a 1 bit subcoding frame sync) is output serially once per frame coincident with SBCL.
3	SBCL	Out	Push-pull output for subcoding bit clock. An 8 bit burst clock at nominally 2.1609 MHz which is used to synchronize the subcoding data.
4	SWCL	Out	Push-pull output for subcoding word clock. A square wave signal at data frame rate (7.35 kHz) used to synchronize the subcoding words and the pause (P) bit.
5	P	Out	Push-pull output for the subcoding pause bit. This signal is derived from the encoded subcoding word and is used to indicate a music pause. A debounce circuit is incorporated to eliminate erroneous data.
6	HFD	In	Input from external high frequency detector. When this signal is high the frequency detector output (FD) and phase detector are enabled. (This input is kept High.)
7	HFI	In	Non-inverting input to the level detector. A differential signal of between 0.5 V and 2.5 V peak-peak is required between pins 7 and 8 to drive the level detector correctly.
8	HFI	In	Inverting input to the level detector.
9	FB	Out	Inverted feedback output from the level detector. These outputs (FB and FB) have a nominal impedance of 10 kΩ and will default to 1/2 VDD1 when a dropout is sensed.
10	FB	Out	Non-inverted feedback output from the level detector (see FB).
11	DEFM	Out	Push-pull output for EFM (Eight-to-Fourteen Modulation) data after it has passed through the level detector. (This pin is not used.)
12	PD2	Out	Phase detector output signal. These outputs (PD1 and PD2) have a nominal impedance of 10 kΩ and the differential DC content of the signals is a measure of the phase difference between the data and the internal 4.3218 MHz clock.
13	PD1	Out	Phase detector reference signal. (see PD2.)
14	VSSD	-	Digital ground. Main ground terminal.
15	VDD2	In	+12 V supply.
16	OA1	In	Non-inverting input to the operational amplifier.
17	OA2	In	Inverting input to the operational amplifier.
18	OA3	Out	Source follower output of the operational amplifier.
19	VSSA	-	Analog ground. Ground terminal for operational amplifier only. Connected internally to VSSD via a nominal 25 Ω resistor.
20	VCO1	In	Input to voltage controlled oscillator amplifier. The amplifier is a simple inverter designed for up to 10 MHz operation. The frequency control is achieved via an external "Varicap" tuned circuit.
21	VCO2	Out	Output from voltage controlled oscillator amplifier. The load for the inverting transistor may be turned off for test purposes by reducing VDD2 to 0 V.
22	CEFM	Out	A push-pull output from the internal 4.3218 MHz clock generator. (This pin is not used.)
23	FD	Out	Three state push-pull output from the frequency detector. This output has a nominal 1 kΩ impedance when active but assumes a high impedance state once the system is in lock.

Pin No.	Signal Name	In/Out	Description
24	FSDE	Out	Push-pull output for frame sync signal to the Error Corrector IC U504. A positive going pulse occurring at the end of each data frame (nominal frequency 7.35 kHz).
25	SSDE	Out	Push-pull output for symbol sync signal to the Error Corrector IC U504. A negative going pulse occurring during the last bit of each data symbol (nominal frequency 254 kHz).
26	CLDE	Out	Push-pull output for data bit clock to the Error Corrector IC U504. An 8 bit burst clock at nominally 2.1609 MHz which is used to synchronize the data to U504.
27	DADE	Out	Push-pull output for data to the Error Corrector IC U504. Serial data consisting of 32 x 8 bit symbols per frame which is synchronized to CLDE.
28	VDD1	In	+5 V supply.

General Description of Demodulator IC:

The SAA7011 Demodulator IC forms the front-end of the compact disc digital audio decoding system, supplying demodulated data and timing signals to the Error Corrector SAA7020 and the subcoding microprocessor.

The detected signal from the disc is amplified and filtered externally and then converted to a digital signal via the level detector. This is an adaptive data slicer which relies on the nature of the modulation system to determine the optimum slicing level.

A frequency detector and a phase detector provide the coarse and fine control signals for the phase locked loop (PLL) system. The gain is supplied by an internal operational amplifier which drives a voltage controlled oscillator (VCO) running at twice the input data rate which is nominally 4.3218 MHz. The oscillator output is divided by 2 within the main clock generator which then clocks the input shift register and the timing chain. This clock signal completes the PLL loop when it is compared with the incoming data in the phase detector.

After the phase detector the data is clocked into the 23 bit input shift register to enable the frame sync pattern to be detected. Also, a minimum and maximum data length detector provides frequency limit signals (Tmin and Tmax) for the frequency detector.

The frame sync signal is used to reset the ÷588 slave-counter which, together with a ÷17 symbol rate counter, supplies timing signals for clocking the Eight-to-Fourteen Modulation (EFM) decoder and the subcoding outputs. The data is read from the input shift register in symbols of 14 bits which are latched and then decoded into 8 bit data words. The subcoding part consists of only one word per frame (see Fig. 8.1.15), therefore the output (SDATA) is a burst of 8 bits of data accompanied by a 2.1609 MHz burst clock signal (SBCL) (see Fig. 8.1.16). One bit of this subcoding output data is replaced by a subcoding frame sync bit (SF) which is decoded from either of two special EFM codes. The displaced bit is known as the Pause or P bit and is latched to its own output via a debounce circuit to remove erroneous changes.

The ÷588 slave counter also provides a sync coincidence pulse which occurs when two detected sync pulses are precisely one frame length apart (588 clock cycles). This is used by the lock indication counter as an "in-lock" signal to reset the counter and disable the frequency detector output (FD). If the system goes out of lock for any reason and the sync pulses cease then the lock indication counter will count frame periods and after 63 frames will enable the frequency detector output.

The sync coincidence pulse is also used via a delay line to reset the protected ÷588 master counter. The counter is prevented from accidental reset by erroneous sync patterns by accepting only coincident sync pulses or sync pulses which occur during a predetermined "window" at the beginning of each frame. This window is wide enough to allow for PLL bit slips, but narrow enough to avoid false sync signals generated by corrupt data.

The data to the Error Corrector (DADE) consists of 32 x 8-bit symbols per frame with half bit gaps between each symbol and a much longer gap during the frame sync period. It is this longer gap that will change in length when corrupt data upsets the timing system.

The ÷588 master counter, together with a second ÷17 symbol rate counter, is used to time the data and clock signals to the Error Corrector SAA7020 (see Fig. 8.1.16). In this way, even if the data has been corrupted, the timing signals are correct and only re-synchronized after a complete frame has been sent to the Error Corrector.

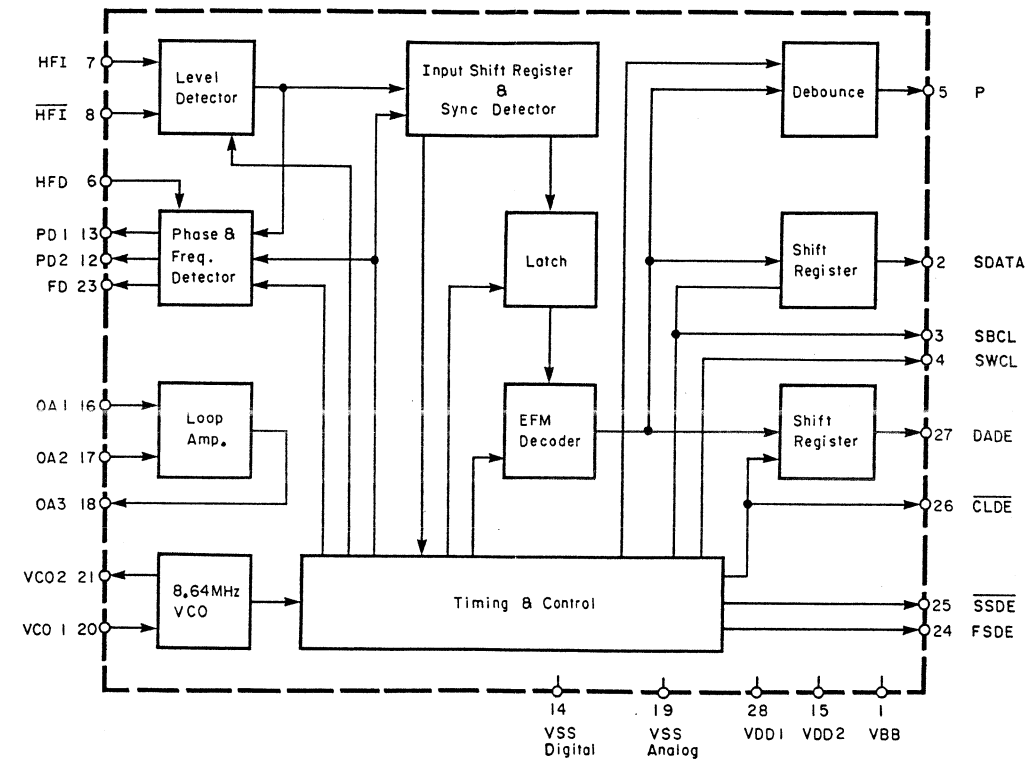

Fig. 8.1.14 Demodulator IC SAA7011

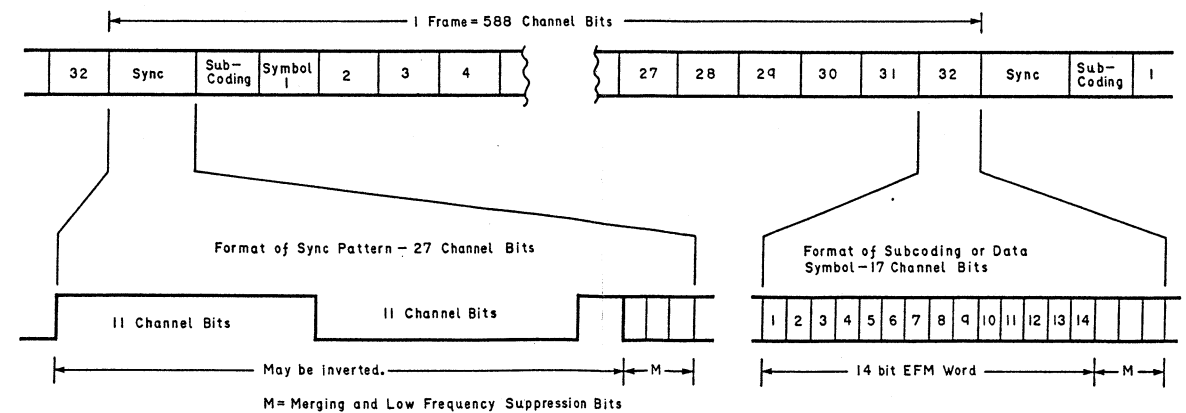
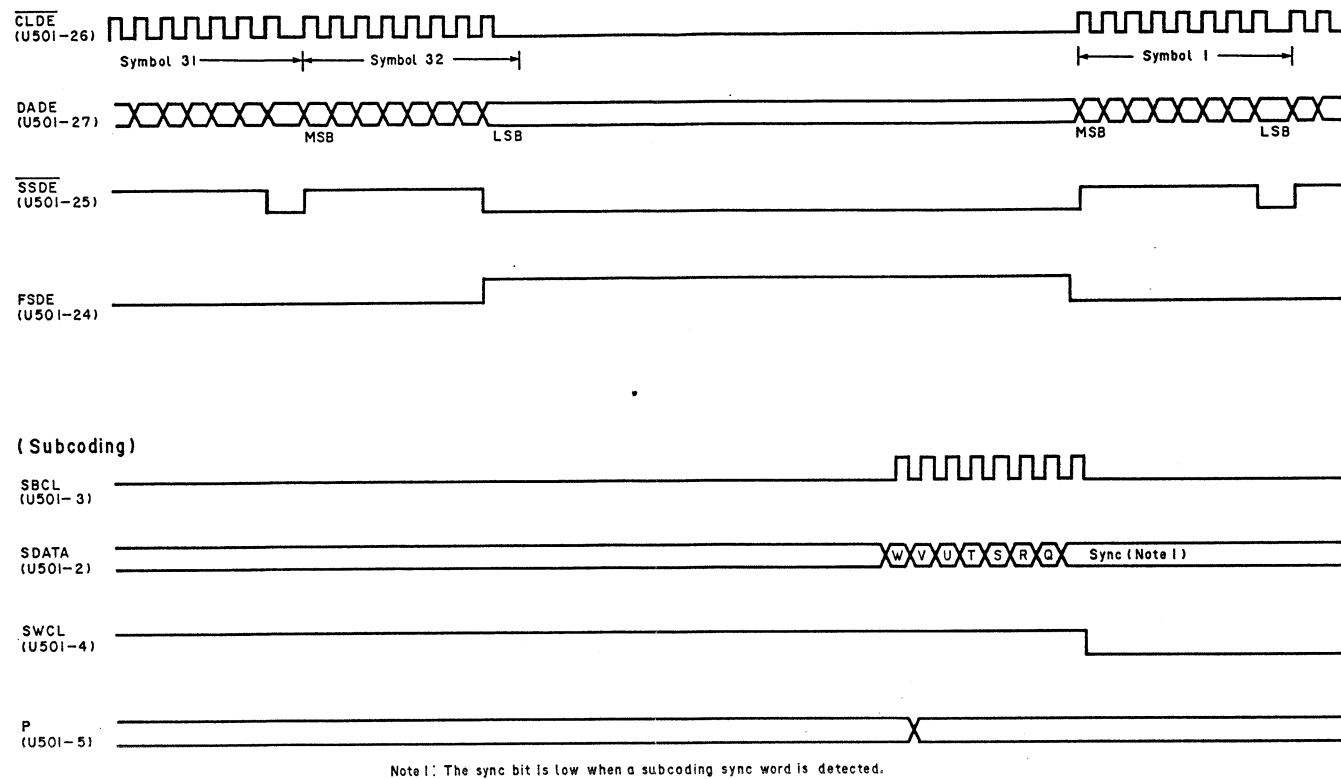

Fig. 8.1.15 Input Waveform to HF Pin (SAA7011)

(To Error Corrector)



Note 1: The sync bit is low when a subcoding sync word is detected.

Fig. 8.1.16 Output Waveforms (SAA7011)

Description of Error Corrector IC U504 (SAA7020)
(See Figs. 8.1.17 and 8.1.18.)

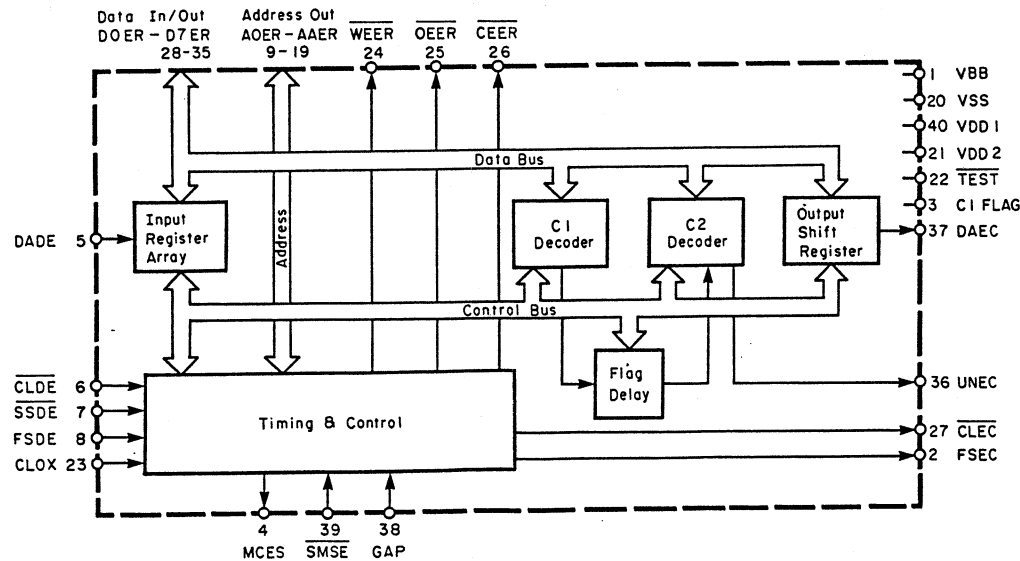

Fig. 8.1.17 Error Corrector IC SAA7020

Pin Description of Error Corrector IC:

Pin No.	Signal Name	In/Out	Description
1	VBB	In	This pin will be connected externally to a -2.5 V supply for back bias.
2	FSEC	Out	Output data clock, data is valid on the falling edge. See Fig. 8.1.18.
3	C1 Flag	Out	This pin is not connected for normal operation, it is for testing purposes. Indicating Flags in the C1 Flag store and hence showing the positions of multiple errors.
4	MCEs	Out	This is an open drain output providing a pulse-width modulated signal to control the rate of data entry. If the data rate has been correct for a period, MCEs will have a 50% duty cycle. If MCEs is mostly high data is entering too slowly and if MCEs is mostly low data is entering too quickly.
5	DADE	In	This pin taken in the data for processing from SAA7011 (Demodulator IC). Data is clocked in by CLDE in 8 bit symbols, MSB first. See Fig. 8.1.18.
6	CLDE	In	This is the clock for the data input. Data is accepted into DADE on the negative edge of CLDE.
7	SSDE	In	This signal is the output from SAA7011. This signal indicates the last bit of each 8 bit symbol. If it is low during the negative transition of CLDE a symbol is counted and clocked in, therefore SSDE must remain low for only one negative transition in eight for correct operation.
8	FSDE	In	This signal is the output from SAA7011. A high on this pin during the negative transition of CLDE indicates the end of a frame of data. The minimum duration of FSDE is critical at high rates of data input, to ensure no FSDE pulses are missed causing erroneous speed indications of MCEs.
9-19	AOER-AAER	Out	Eleven address outputs to 2KB RAM. Provided data is being received by DADE, CLDE etc., then address AOER to AAER are completely exercised every four frames enabling refresh to be automatic for pseudo-static RAMs.
20	VSS	-	Ground supply for SAA7020.
21	VDD2	In	Nominal 12 V supply.
22	TEST	In	This pin should be connected directly to VDD1 or VDD2 for normal operation.
23	CLOX	In	This is the basic clock input for the SAA7020. A nominal frequency of 4.2336 MHz is fed in from the SAA7000.
24	WEER	Out	Write enable bar for control of the memory, when low SAA7020 is writing to the RAM.
25	OEER	Out	Output enable bar for control of the memory output buffers, when low the memory outputs must be tri-stated.
26	CEER	Out	Chip enable bar for use with pseudo-static memories. (This pin is open.)
27	CLEC	Out	Output data clock, data is valid on the falling edge. See Fig. 8.1.18.
28-35	DOER-D7ER	In/Out	An 8 bit parallel data bus between SAA7020 and the RAM. The outputs are high impedance state when OEER is low.
36	UNEC	Out	Unreliable data flag, when high indicates that output data is unreliable. During active data output (i.e., when CLEC is operating) UNEC applies to each symbol of 8 bits of data output at that time. Before each data word of two symbols is output, UNEC applies to the whole data word that will follow in five frames time.
37	DAEC	Out	Data output to SAA7000. Data is output in 16 bit words separated by gaps. Each word is in two's complement format with MSB first and is made up of 2x8 bit symbols. Between the data words the state of the GAP pin is output. Data is valid on the falling edge of CLEC. See Fig. 8.1.18.
38	GAP	In	The state of this pin is reflected in the state of the data output between words on DAEC. It is used to pass information with the data words. A high on GAP making the GAP level on DAEC high and vice versa. See Fig. 8.1.18.
39	SMSE	In	If SMSE is held low the UNEC output will be held high. This input is used to cause SAA7000 to mute the data.
40	VDD1	In	Nominal 5 V supply.

General Description of Error Corrector IC:

The SAA7020 Error Corrector IC is for the detection and correction of erroneous data samples in the compact disc digital audio decoding system. Receiving demodulated data and timing signals from the SAA7011 Demodulator IC SAA7020 sends data samples, corrected if necessary and possible, and timing signals to the SAA7000 Concealment of Errors by Interpolation and Muting IC. If it is not possible for SAA7020 to correct the erroneous data then the unchanged data and an Error Flag is sent to the SAA7000. SAA7020 Error Corrector IC also supplies the motor speed control signal.

SAA7020 receives serial data from the SAA7011 (Demodulator) at the demodulator clock rate through the input DADE into the "Pre-Fifo" where it is converted to an 8 bit parallel format and then clocked out through the Fifo-to-RAM section at the system crystal clock rate to a 2K x 8 bit RAM via I/O ports DOER to D7ER.

The "Pre-Fifo" is also an effective "de-jitter" circuit eliminating effects such as "wow" and "flutter" and can cope with deviations from the nominal data rate of plus and minus 2-1/4 frames of data. From the difference between the nominal data rate and the actual data rate the motorspeed control signal MCEs is derived. This forms a feedback loop with the motor to control the disc speed and hence the rate data is read into the "Pre-Fifo". The RAM is used as a temporary data store from which the data, stored in the form of a "Reed Solomon" code, is de-interleaved and read back into SAA7020 via the I/O ports into the syndrome generation and locator section. The syndromes formed are multiplied around to check for erroneous symbols. If one error is detected the error is corrected and the data symbols are written back to the RAM with some parity symbols being discarded. If more than one error is detected the data is read back to the RAM unchanged but an internal C1 flag is set to mark these symbols as unreliable.

The data in the RAM is then de-interleaved and read back into SAA7020 for a second time. The symbols are then checked for errors as previously. If one error is detected it is corrected and the symbols read back to the RAM as previously. If two errors are detected the information from the syndrome generator multiplication plus the positional data in the Flag store obtained in the C1 attempt at correction is used to correct both symbols. This is done by selecting stored data in the ROM and multiplying it with the data in the C2 stack. The corrected data is then read back to the RAM. If more than two symbols are in error the data is read back to the RAM unchanged but a flag is set to mark these symbols as unreliable. At this stage the remaining parity bits are discarded.

The data is then held in the RAM to give a five frame delay so that the advanced error flag can be sent to the SAA7000 to warn it to mute the relevant data, this flag is sent via the UNEC Output Pin. The UNEC Output Pin also warns of data to be interpolated and to mute if the SMSE Input Pin is active, i.e., as between tracks. The data is then read back into SAA7020 in parallel and serially shifted out through the DAEC Output Pin to the SAA7000.

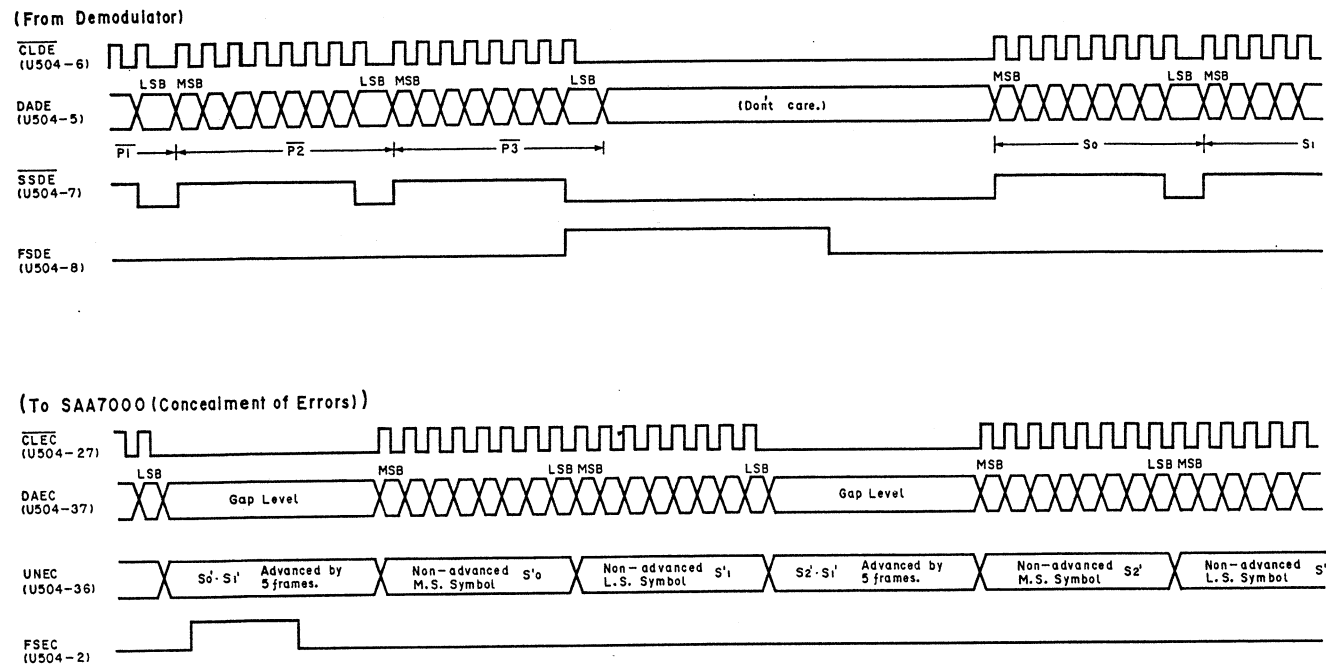

Fig. 8.1.18 Typical Input/Output Waveforms (SAA7020)

Description of Concealment of Error IC U506 (SAA7000)
(See Figs. 8.1.19 and 8.1.20.)

Pin Description of Concealment of Error IC:

Pin No.	Signal Name	In/Out	Description	Pin No.	Signal Name	In/Out	Description
1	VBB	In	This pin is used for the supply of an external VBB of -2.5 V.	6	CLOX	Out	CLOX is a buffered form of the clock on XTAL1.
2	FSEC	In	FSEC is an active high pulse which indicates the start of a "Frame". It is used to synchronize the descramblers to the data frames (12 samples) and also SAA7000 clocks to the CLEC input clock, aligning the gap in the internal clock to the FSEC pulse. Two consecutive FSEC pulses must occur, each having a pulse width of approximately 6 CLOX cycles. The trailing edge of the second pulse must occur one frame later than the trailing edge of the first pulse, for a re-synchronization to occur.	7	XTAL2	Out	XTAL2 is the output drive to a crystal to provide the main clock.
3	CLEC	In	CLEC is the input clock, having a clocking period of 2 x CLOX period, used for loading data from SAA7020. On the negative edge, data at DAEC is shifted in to the input shift register. CLEC clocks a data sample in, then stays low for a gap of 16 CLOX cycles (see Fig. 8.1.20).	8	XTAL1	In	XTAL1 is the input pin for crystal circuit.
4	DAEC	In	DAEC is the data input in 2's complement form with MSB leading. During the gap in CLEC the DAEC input is used to select the output format, a high selects 2's complement, a low offset binary (see Fig. 8.1.20). Note: the data is descrambled internally so the input sample format is complex.	9	VSS	-	Ground supply pin.
5	UNEC	In	UNEC is the error flag input. During the period when CLEC clocks in the DAEC input, UNEC is low only if the present symbol (8 bits see Fig. 8.1.20) is valid. During the CLEC gap before a word UNEC is low only if the whole of the data word due to arrive 5 frames later is valid.	10	VDD2	In	Nominal 12 V supply pin.
				11	STR2	Out	STR2 is an active high strobe pulse of 2 CLOX cycles duration occurring every 24 CLOX cycles. (This pin is not used.)
				12	STR1	Out	STR1 is an active high strobe pulse of 2 CLOX cycles duration, occurring every 96 CLOX cycles, after each pair of data words have been output. It is used to strobe data to SAA7030 (Digital Filter IC). Both STR1 and STR2 are re-synchronized to XTAL1 to obtain minimum jitter.
				13	DLCF	Out	DLCF outputs data for the left channel in either 2's complement or offset binary format, selected by DAEC.
				14	CLCF	Out	CLCF is either a 14 bit or 16 bit output clock, selected by pin 16 (14/16). It is used to clock data from DLCF/DRCF to SAA7030 on its negative edge. (i.e., DLCF/DRCF stable during falling edge, see Fig. 8.1.20.)
				15	DRCF	Out	DRCF outputs data for the right channel in either 2's complement or offset binary format, selected by DAEC.
				16	14/16	In	14/16 selects the bit length of the output clock CLCF.
				17	TEST	In	This pin selects between normal and test modes. For normal operation it should be held at 0 V.
				18	VDD1	In	Nominal 5 V supply pin.

General Description of Concealment of Error IC:

The SAA7000 (Concealment of Errors by Interpolation and Muting IC) is used in the compact disc system to reduce audible annoyance caused by uncorrected erroneous data samples from the SAA7020 (Error Corrector IC).

Data samples (at DAEC clocked in with CLEC) are first descrambled and then separated into left and right samples. A similar descramble and separation is performed on the Error Flag (UNEC). Where no error flags occur the data value is unaffected through SAA7000.

If for either left or right a single "error" is flagged between two "good" samples then linear interpolation is used to replace the erroneous value. If two or more adjacent samples are flagged then the samples in error will be muted. Beginning thirty samples before the first of the consecutive errors, the value of the samples will be attenuated smoothly to zero level, using a $(0 - \pi)$ cosine

shape curve. After the error burst the next thirty samples are attenuated smoothly to full level, using a $(\pi - 2\pi)$ cosine shaped curve. This muting/attenuation occurs to data of left and right channels simultaneously regardless of the source of the mute.

The data (good or processed) is then formatted into 2's complement or offset binary to match the D/A Converters used. This selection is made with a special function of the data input (DAEC). Data is then fed to the left and right outputs (DLCF and DRCF) and is clocked out by the Output Clock (CLCF). Strobes (STR1 and STR2) are generated for the SAA7030 (Digital Filter IC). Fourteen or sixteen bit D/A Converters can be accommodated by use of the Select Input (14/16).

A 2x bit rate clock (CLOX) is fed to the system (SAA7020 (Error Corrector IC) and SAA7030 (Digital Filter IC)), SAA7000 automatically synchronizes to the SAA7020 output using the frame sync (FSEC) pulse for internal timing reset.

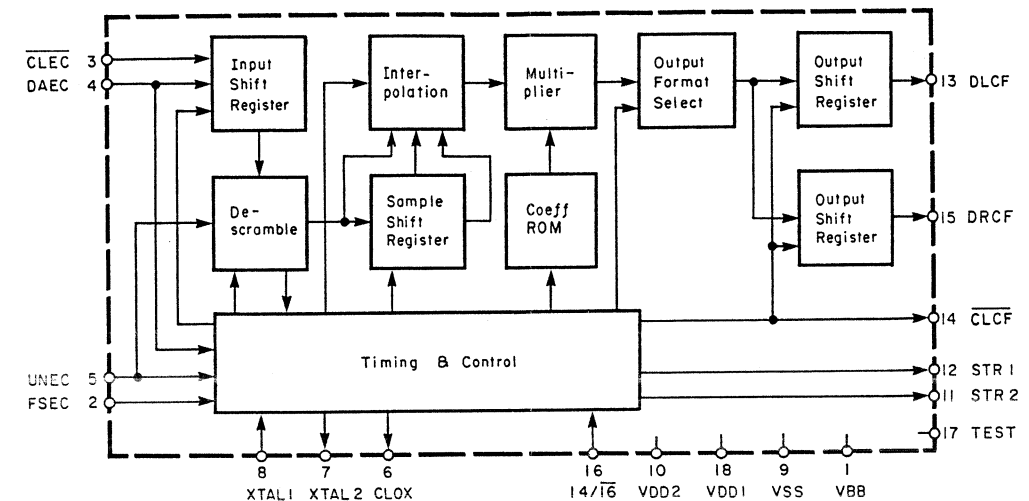

Fig. 8.1.19 Concealment of Error IC SAA7000

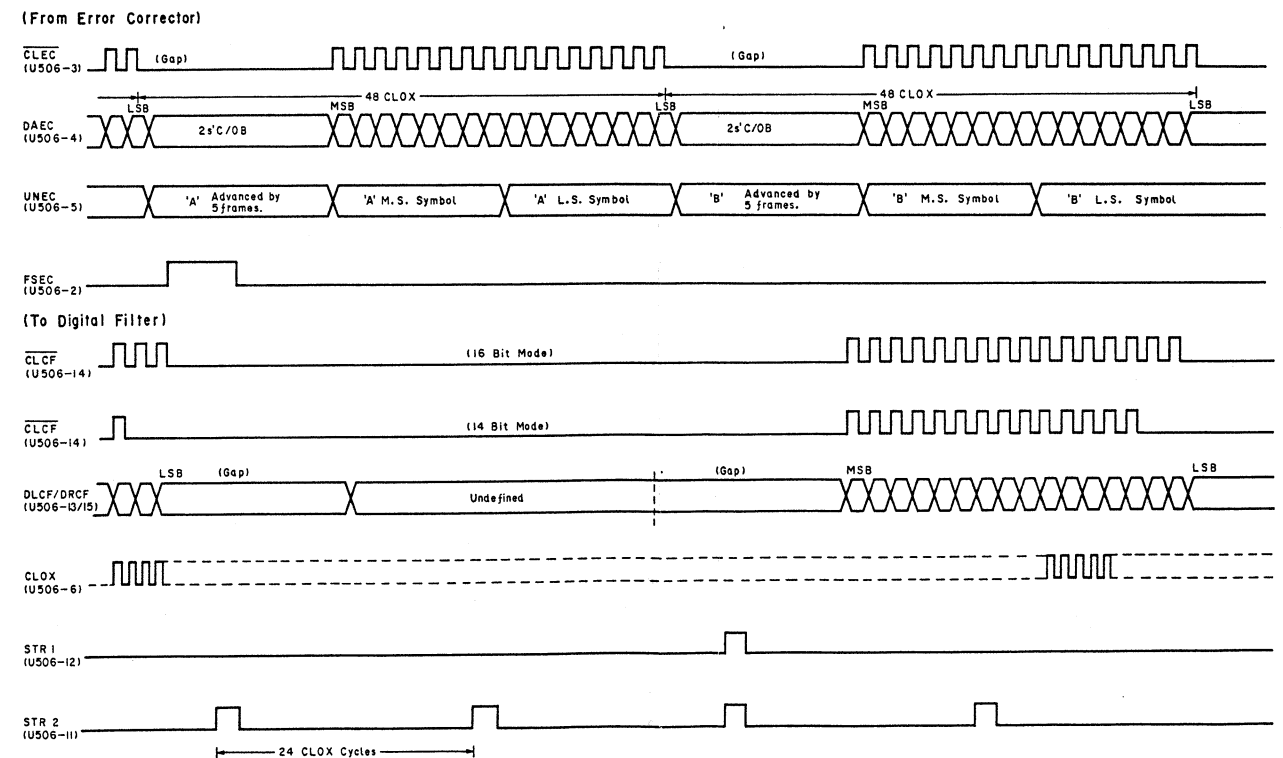

Fig. 8.1.20 Input/Output Waveforms (SAA7000)

Description of Digital Filter IC U507 (SAA7030)
(See Figs. 8.1.21 and 8.1.22.)

Pin Description of Digital Filter IC:

Pin No.	Signal Name	In/Out	Description	Pin No.	Signal Name	In/Out	Description
1	VBB	In	-2.5 V ±0.5 V supply.	17	DRCF	In	Right channel data input. Data should be 16 bit serial, MSB first, offset binary coded. It should be valid on the falling edge of the data clock CLCF.
2	OS	In	Offset select input. When connected to VDD1 the data output has a fixed DC offset of 3%. When connected to VSS the output has no offset. (This pin is connected to VDD1.)	18	CLCF	In	Input data clock. The falling edge of this signal defines input data valid.
3	DLFD	Out	Left channel data output. The data is 14 bit serial, MSB first and is valid on the falling edge of output clock CLFD.	19	CLOX	In	Master input clock. Runs continuously at a nominal frequency of 4.2336 MHz.
6	CLFD	Out	Output data clock, nominal frequency 4.2336 MHz (= CLOX). The falling edge of this signal defines output data valid.	20	DLCF	In	Left channel data input. See DRCF.
7	LAT	Out	Output 176.4 kHz strobe. The rising edge of this pulse says that the output of a 14 bit data word has been completed.	21	STR1	In	Input 44.1 kHz strobe. The circuit's internal timing chain is synchronized by the rising edge of STR1 which must run synchronously with CLOX in accordance with the timings specified in the electrical characteristics.
10	DRFD	Out	Right channel data output. See DLFD.	22	RT	In	Reset test not input. When low resets the part of the accumulator not reset in normal operation to initialize the accumulator for testing. In normal operation should be connected to VDD1.
11	OB	In	Offset binary not input. When connected to VDD1 the output data is coded as 2's complement. When connected to VSS the output data is coded as offset binary. (This pin is connected to VSS.)	23	TE	In	Test enable not input. When low switches the internal circuitry into the sequential scan test mode. In normal operation should be connected to VDD1.
12	VSS	-	Ground.	24	VDD1	In	5 V ±10% supply.
13	VDD2	In	12 V ±10% supply.				
15	TINR	In	Test input (R). Right channel test chain input. In normal operation this pin should be connected to either VSS or VDD1.				
16	TINL	In	Test input (L). Left channel test chain input. See TINR.				

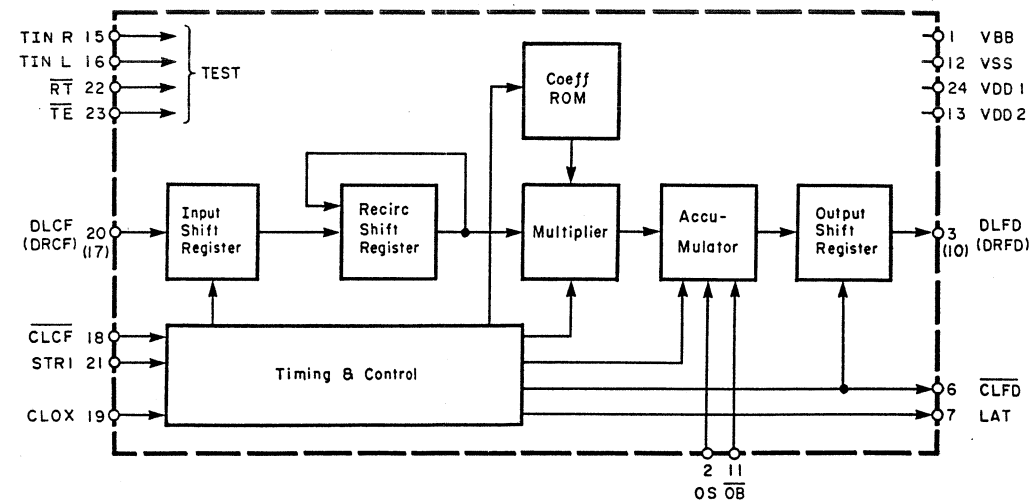

Fig. 8.1.21 Digital Filter IC SAA7030

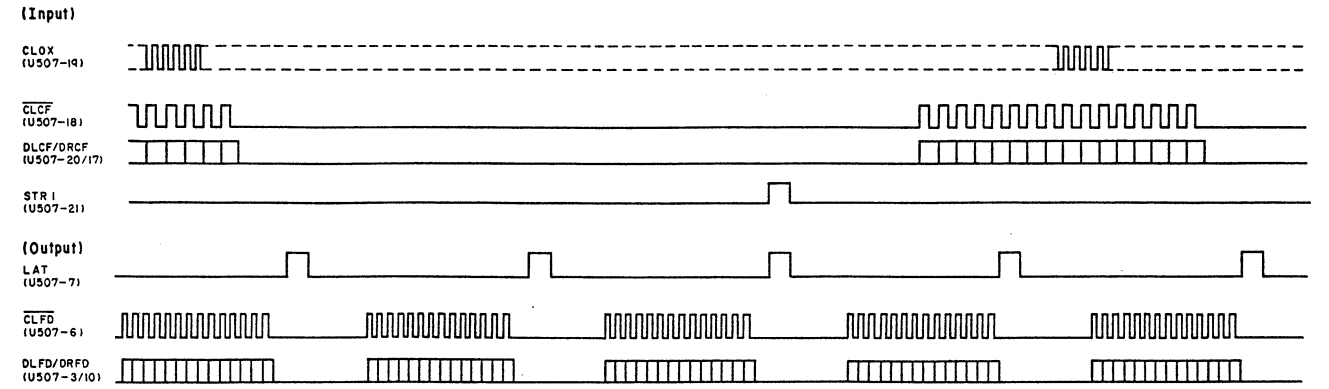

Fig. 8.1.22 Input/Output Waveform (SAA7030)

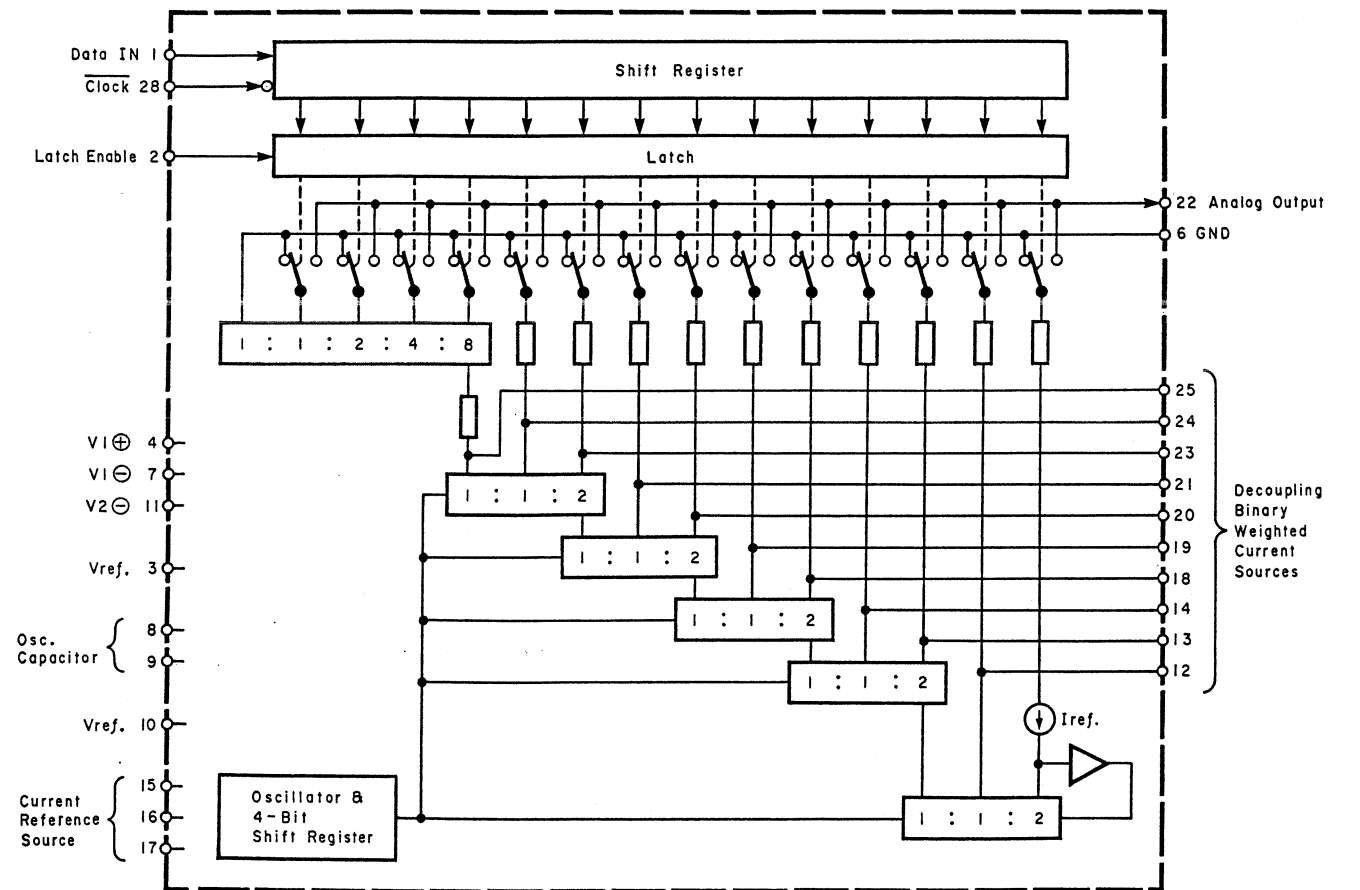

Fig. 8.1.22 D/A Converter IC TDA1540D

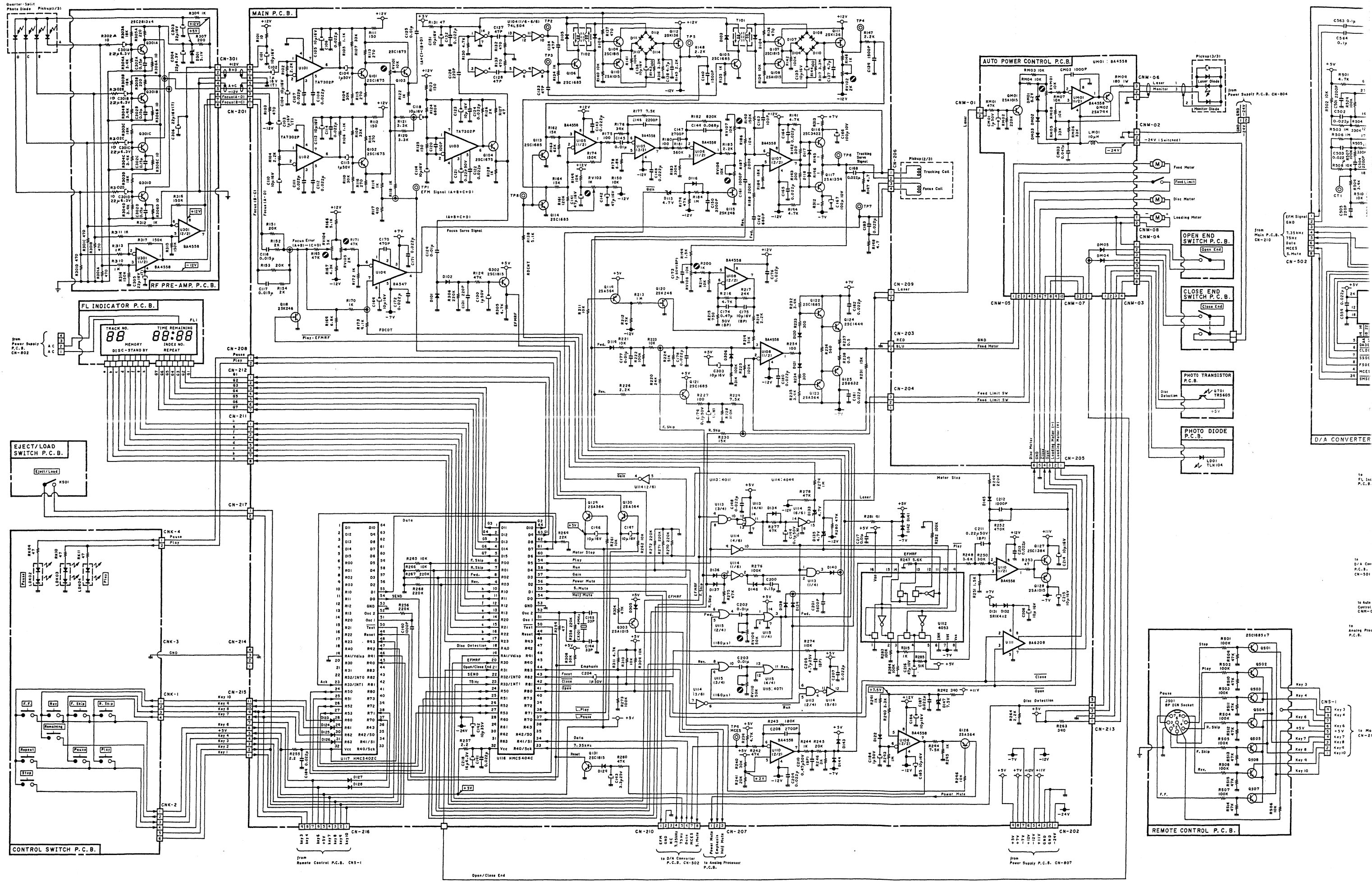

Fig. 8.3

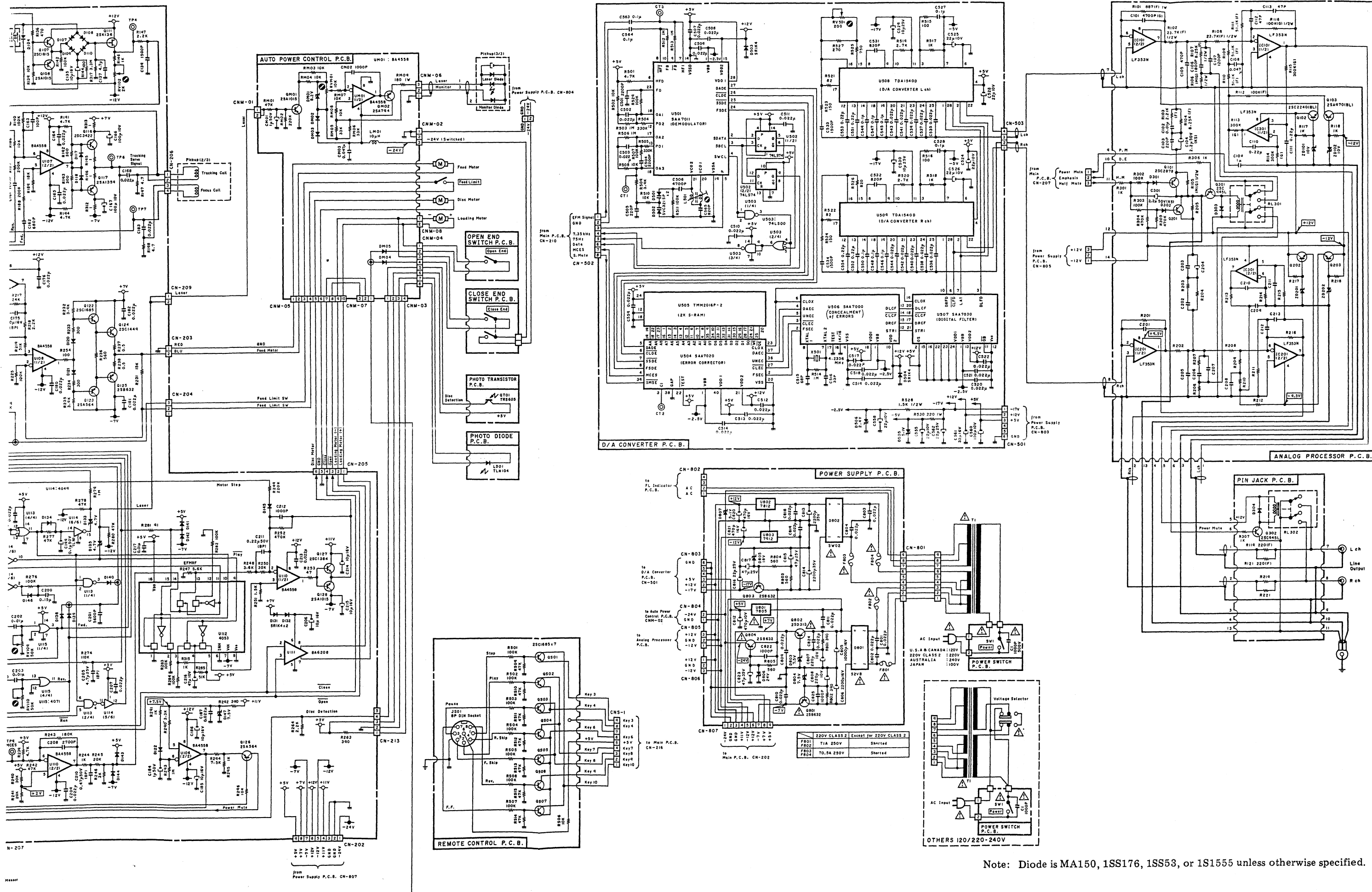

Fig. 8.3

Note: Diode is MA150, 1SS176, 1SS53, or 1S1555 unless otherwise specified.

8.2. Waveforms at Major Points

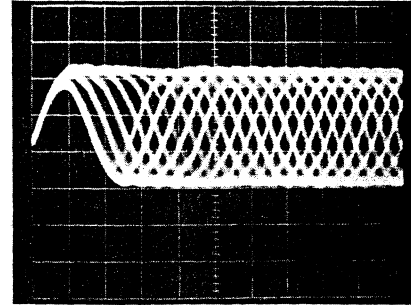

Fig. 8.2.1 EFM Signal at TP1 on Main P.C.B. Ass'y

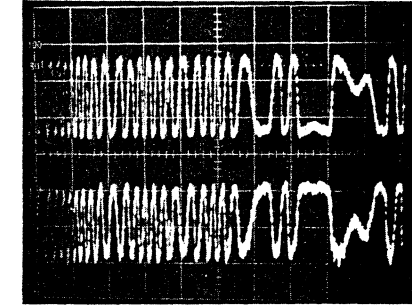

Fig. 8.2.5 Waveforms at TP4/TP5 on Main P.C.B. Ass'y (when RV107 is set to zero)

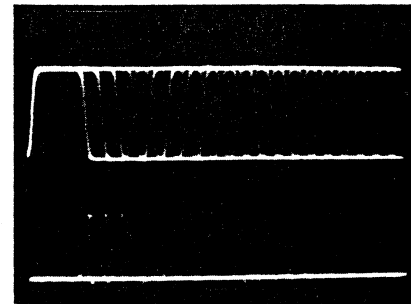

Fig. 8.2.2 Waveforms at emitter of Q104 (above) and TP2 (below) on Main P.C.B. Ass'y



Fig. 8.2.6 Focus Servo Signal at TP7 on Main P.C.B. Ass'y

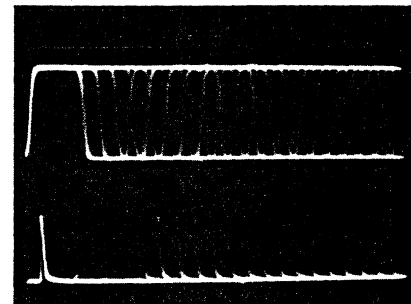

Fig. 8.2.3 Waveforms at emitter of Q104 (above) and TP3 (below) on Main P.C.B. Ass'y

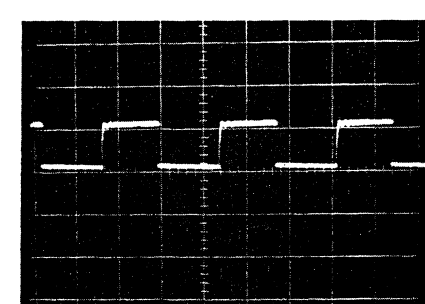

Fig. 8.2.7 MCES Signal at TP9 on Main P.C.B. Ass'y

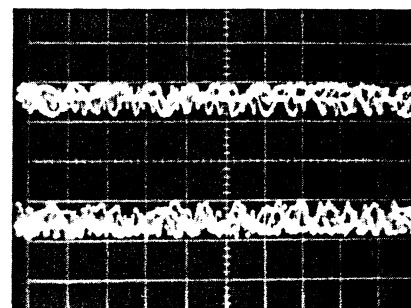



Fig. 8.2.4 Waveforms at TP4/TP5 on Main P.C.B. Ass'y

Warning:

Parts marked with the symbol  have critical characteristics.

Use **ONLY** replacement parts recommended by the manufacturer. It is recommended that the unit be operated from a suitable DC supply or batteries during initial check-out procedure.

Caution:

Before returning the unit to the customer, make sure you make either (1) a leakage current check or (2) a line to chassis resistance check. If the leakage current exceeds 0.5 milliamp, or if the resistance from chassis to either side of the power cord is less than 240 k ohms, the unit is defective. **WARNING — DO NOT** return the unit to the customer until the problem is located and corrected.

9. WIRING DIAGRAM

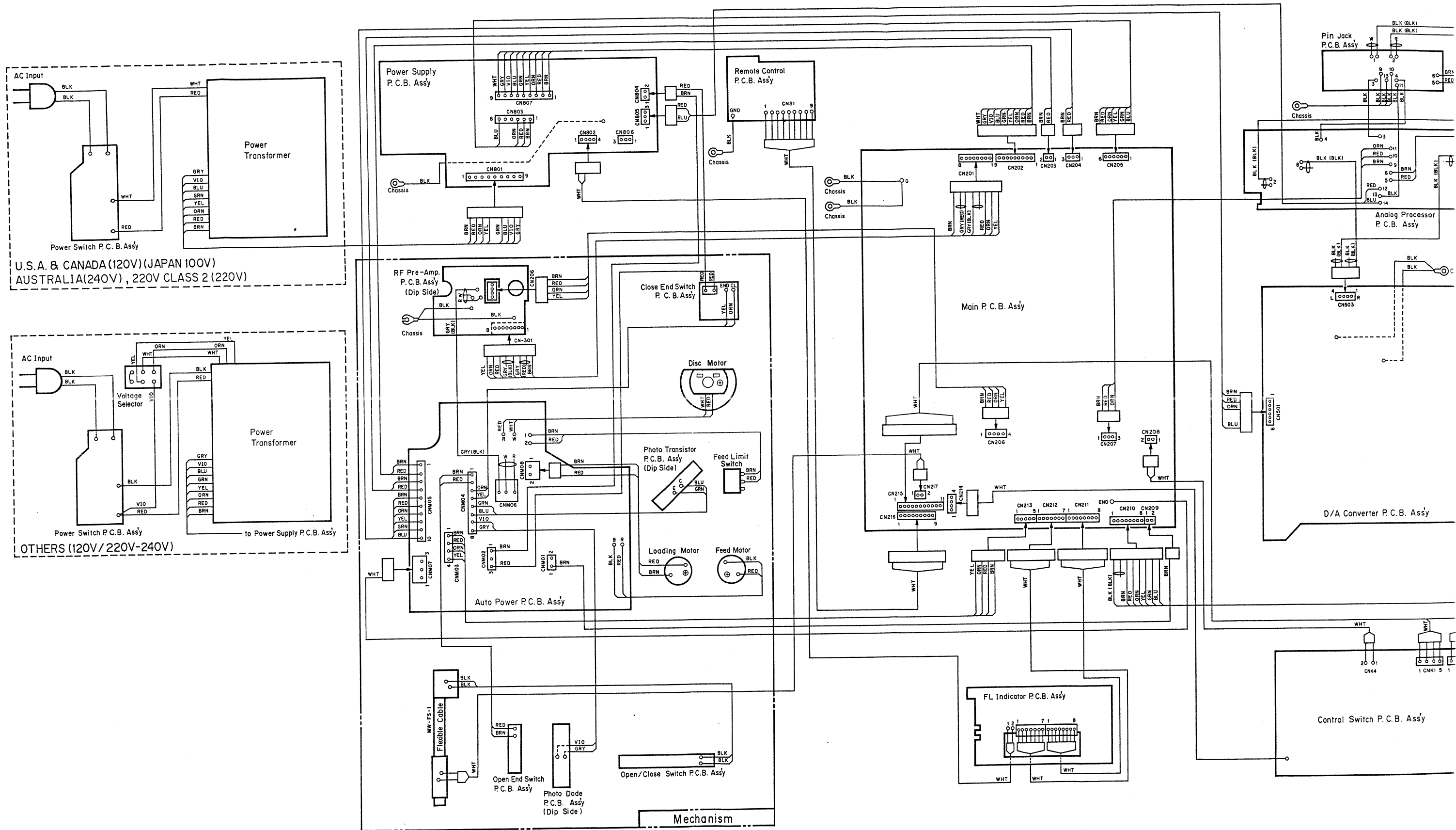
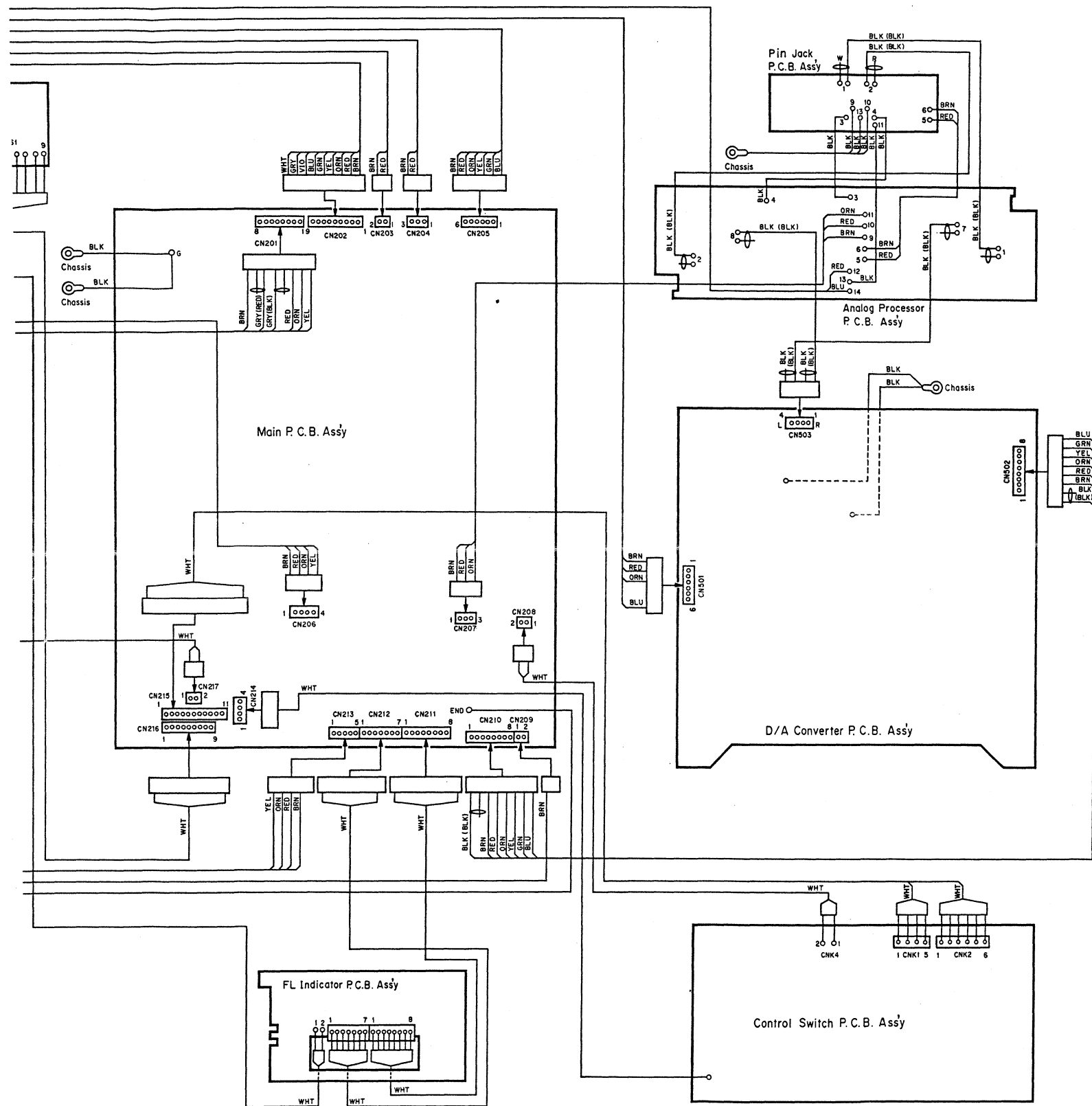

Fig. 9



Notes: 1 Table of wire colors

BRN — Brown	BLU — Blue
RED — Red	VIO — Violet
ORN — Orange	GRY — Gray
YEL — Yellow	WHT — White
GRN — Green	BLK — Black

2. Component side view of the P.C.B. is illustrated unless otherwise specified.

3. Wire tube color is shown in ().

10. BLOCK DIAGRAM

