

Nakamichi 430

FM Tuner Operating Instructions

WARNING — TO PREVENT FIRE OR SHOCK HAZARD, DO NOT EXPOSE THIS APPLIANCE TO RAIN OR MOISTURE.

Please record the Model Number and Serial Number in the space provided below and retain these numbers.

Model Number : Nakamichi 430
Serial Number : _____

CONTENTS:

Physical Layout	1,2
Precautions	2
Connections	3
FM Antenna	3
Operation	5
Multipath Output Jacks	6
Block Diagram	7
Specifications	7
Performance Data	8

Congratulations! You have purchased one of the finest electronic components available today.

The Nakamichi 430 FM Tuner is distinguished by a level of quality and performance that is rarely found among modern mass-produced audio components. World famous Nakamichi engineering and quality assurance guarantee that you will enjoy your 430 FM Tuner for many years to come.

Although many of the 430's features are self-explanatory, we strongly suggest you take the time to read this manual in its entirety before attempting operation.

Thank you.

NAKAMICHI RESEARCH INC.

Physical Layout

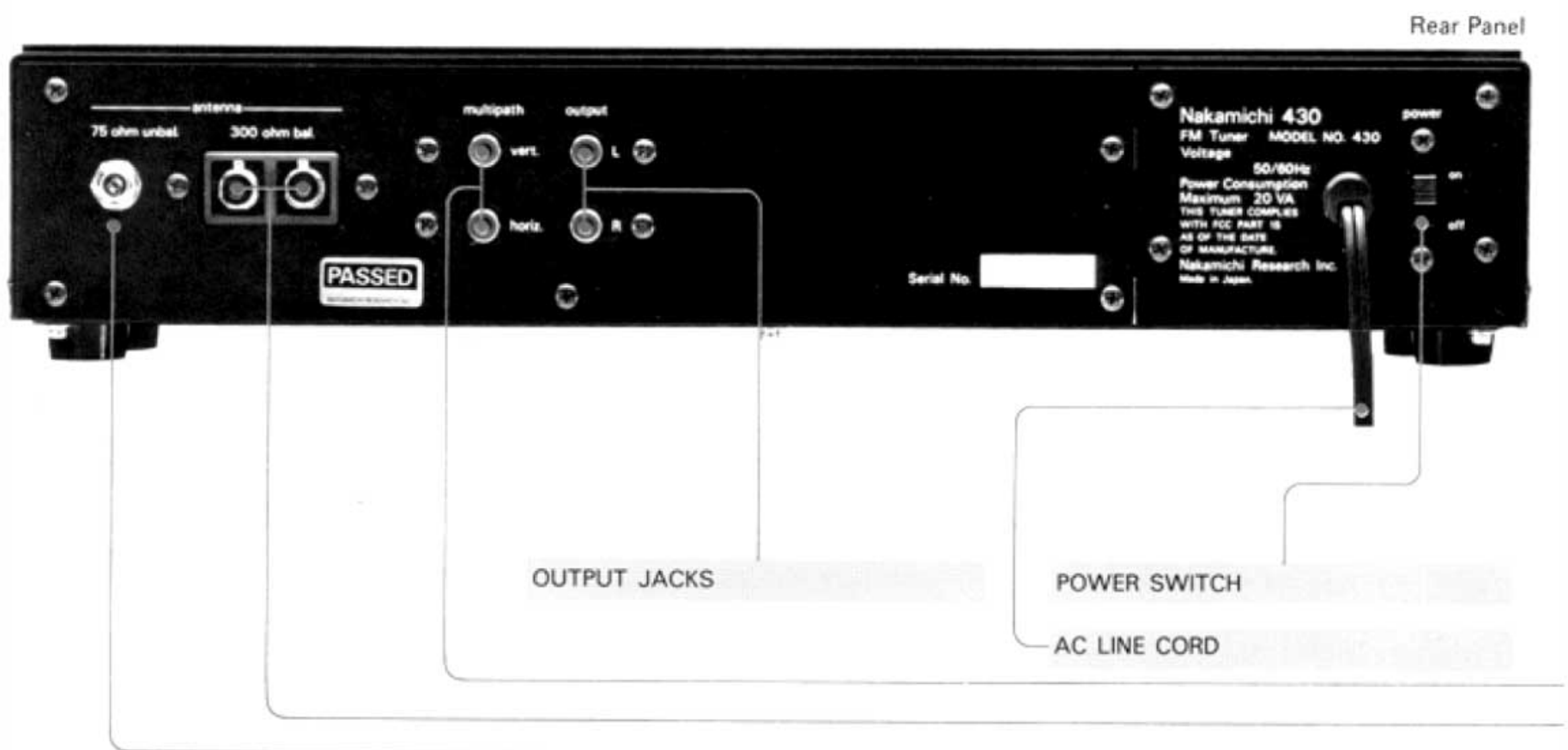
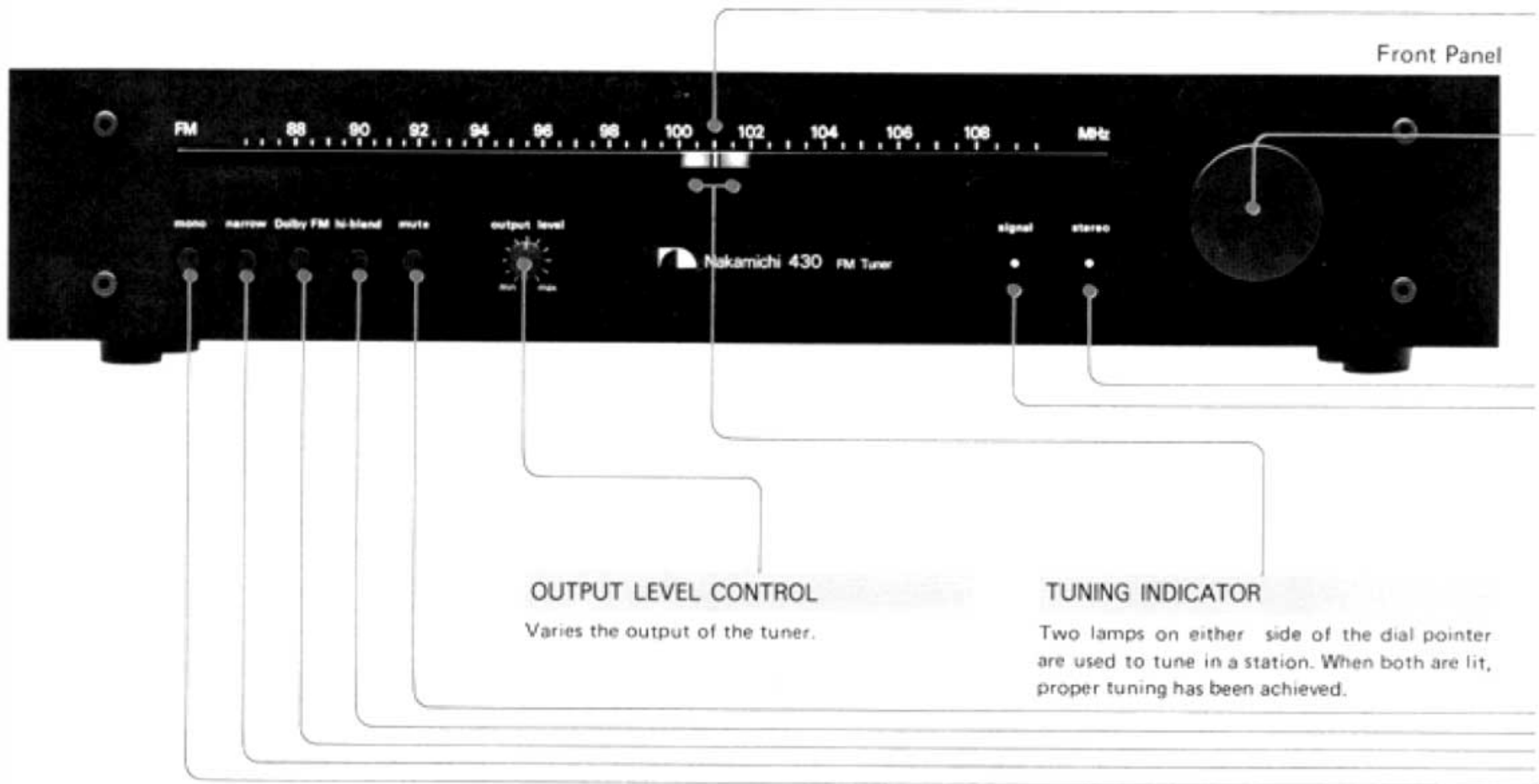



DIAL POINTER

Slides across when the tuning dial is turned to indicate FM station frequency (in Megahertz).

TUNING DIAL

STEREO INDICATOR

Indicates FM stereo reception.

SIGNAL INDICATOR

Glowes to indicate high signal strength, and is thus useful for antenna positioning.

MUTING SWITCH

Activates interstation muting for noise-free station selection.

HI-BLEND SWITCH

A noisy stereo reception can be improved by selecting hi-blend, which cancels random noise by sacrificing a certain amount of high frequency separation.

DOLBY FM SWITCH

When the 430 is fitted with an optional Dolby Noise Reduction system circuit board, depressing this switch will activate the Dolby circuit and select the required 25 μ s de-emphasis.

NARROW SWITCH

Changes tuner selectivity from "normal" to "narrow" for better reception in areas with many FM stations close together on the dial.

MONO SWITCH

Selects monaural operation mode.

MULTIPATH OUTPUT JACKS

Provides a signal for visual (using oscilloscope) or aural detection of multipath

300-ohm FM ANTENNA TERMINALS

For the connection of all antennas utilizing 300-ohm twin-lead cable (balanced), including the provided dipole (T-shaped ribbon) antenna.

75-ohm FM ANTENNA CONNECTOR

For the connection of an external antenna via a 75-ohm unbalanced coaxial cable. A mating connector is provided for custom installation.

1. It is highly recommended that you turn down the volume control on your preamplifier or amplifier before changing stations, even with the interstation muting on. Sudden introduction of a loud signal source may damage your amplifier and/or loudspeaker.
2. Make sure that the power to your preamplifier or amplifier and the 430's power are off before you attempt interconnections.

Connections / FM Antenna

● Connections

1. Audio

Using a standard RCA phono plug type stereo connector cable, connect the tuner outputs of the 430 to the AUX or TUNER input of your preamplifier or integrated amplifier. Observe left and right markings. The maximum output level of the 430 is 500 mV at 50% modulation.

2. Power

Connect the AC Line Cord of the 430 to a convenient AC outlet. Utilizing a switched outlet on your preamplifier or integrated amplifier will eliminate the need to turn the 430 on and off separately with its power switch.

3. FM Antenna

Refer to next section.

4. Multipath Output Jacks

Refer to later section dealing specifically with multipath detection (page 6).

● FM Antenna

The quality of FM reception will only be as good as the signal entering the tuner at the antenna terminals. Although there is little you can do if the FM station's broadcast quality is poor, you can ensure that the 430's FM section is performing at its best by selecting the proper FM antenna and installing it correctly. The following is intended as a guide. Your high fidelity dealer or local antenna specialist will be able to provide further information, if necessary.

Dipole Antenna

If you are located in a metropolitan area or otherwise close to the FM broadcasting stations to which you will be listening (i.e., within several miles), and if your immediate area is free of tall obstructing structures, the dipole (T-shaped ribbon) antenna provided with the 430 will most likely be more than adequate for quality FM reception. Connect the dipole to the 300-ohm balanced terminals on the rear

panel of the 430. Stretch the dipole into a "T" shape, and position it for best reception while listening to the broadcast. If the signal sounds weak and distorted, or if the 430's "signal" lamp fails to light with most stations, the use of a directional outdoor FM antenna will yield significant improvements. If you are receiving stations strongly, but the sound is distorted, this may be an indication of strong multipath reception (distortion caused by multiple arrivals of the same signal at the antenna terminals — tall structures nearby will cause multipath reception). In this case as well, the use of a directional outdoor antenna will improve reception quality.

Other Indoor Antennas

In some cases, a slight improvement in reception can be gained by using "rabbit ears" or other indoor FM/television antennas instead of the dipole. If you are in a weak signal area, however, any improvement with these indoor-type antennas is likely to be marginal at best.

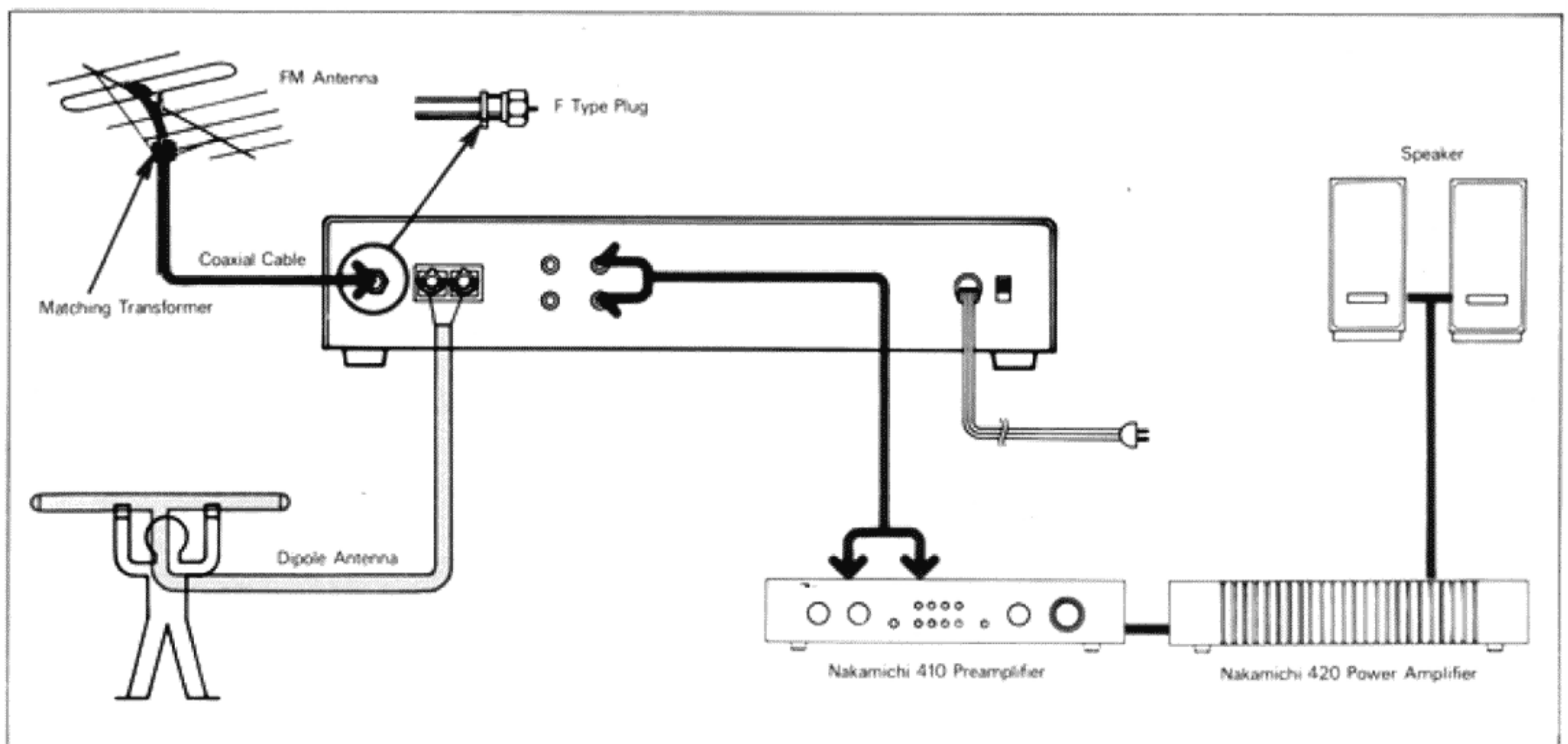

Outdoor Antennas

Outdoor antennas vary in gain and directionality. Generally, antennas with the greater number of elements will have higher gain. For FM, choose an antenna with 3 to 8 elements, depending on your distance from the broadcasting stations and other area conditions. Most outdoor FM antennas can be connected to the 430's 300-ohm balanced terminals using 300-ohm twin-lead antenna cable. Although this is preferable, some installations will require the use of coaxial cable because of noise sources, such as automobile engine ignition or high voltage power lines. For coaxial lines, utilize the 75-ohm unbalanced connector on the 430. Some antennas will require a matching transformer for 75-ohm operation. Consult an antenna specialist for specific recommendations.

Installation of 75-Ohm Coaxial Connector

The F-type connector supplied with the 430 mates with the 75-ohm unbalanced antenna connector on the rear panel. If your antenna connection is via 75-ohm coaxial cable, you can install the provided connector onto the cable yourself with just a knife and pliers.

1. Cut and remove about 15mm of the outer insulation (cover).

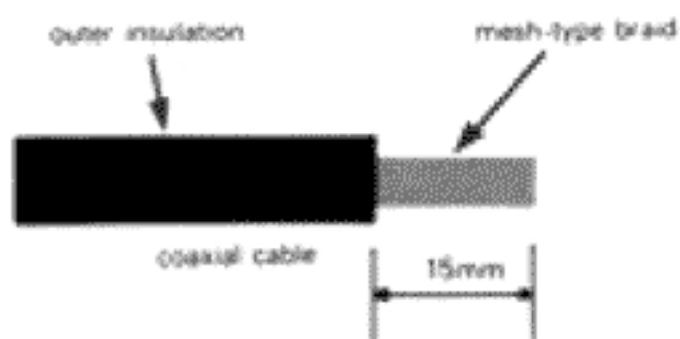

2. Cut and remove the mesh-type braid with the knife, but leave about 2mm at the base, right next to the edge of the outer insulation.



3. Cut and remove the inner insulation (cover), leaving about 5 mm from the edge of the outer insulation.



4. Pass the clamp ring over the cable, and spread the mesh-type braid with your fingers.

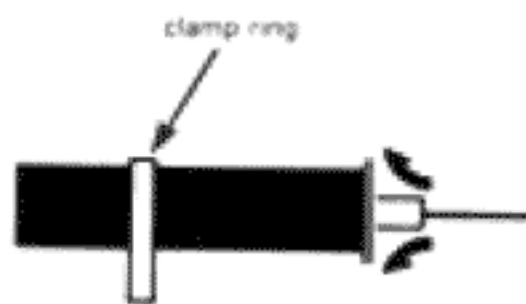

5. Push the pointed end of the connector into the cable, making sure it goes in between the braid and the inner insulation.



6. Press and crimp the clamp ring with the pliers to secure the connector.

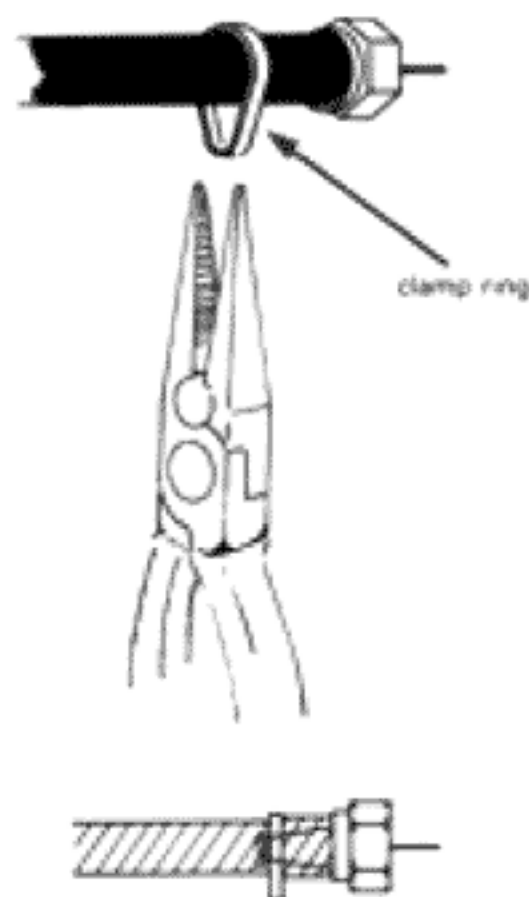

The coaxial cable is now ready to be connected to the 75-ohm terminal on the rear panel of the 430.

Outdoor Antenna Installation Hints

1. If you are fairly close to FM broadcasting stations but find you have to use a directional outdoor antenna to reduce multipath, the signal strength may be sufficiently high to cause overloading of the 430's FM front end (heard as a severely distorted signal). In such instances, an antenna attenuator must be installed.
2. Since most outdoor FM antennas are highly directional, they must be "aimed" toward the desired station's broadcast antenna. If you live in an area where FM stations exist in several different directions, you may have to install a rotor system in order that you can remotely alter the direction of the antenna.
3. Always place outdoor antennas as far from highways and high power lines as possible. Follow your antenna dealer's recommendations for proper placement.
4. 300-ohm twin lead cable is superior to coaxial types in that there is very little transmission loss, even with relatively long lengths (the loss factor is approx. 0.04 dB/meter). The drawback of 300-ohm twin lead, however, is that it easily picks up noise. A 75-ohm coaxial cable system is much less susceptible to noise pick-up, but cable loss is not negligible (typically 0.12 dB/meter). If noise problems exist in a weak signal situation, special low-loss coaxial cables are available from most antenna dealers.

Operation

The tuning system employed in the Nakamichi 430 is somewhat unconventional in that there are no tuning meters. Instead, the 430 utilizes indicator lamps integrated into the dial pointer for very precise station selection.

1. Lower the volume control on your preamplifier or integrated amplifier to minimum.
2. Set the output level control on the 430 to maximum (fully clockwise).
3. Turn the tuning dial of the 430 to the frequency of the desired station. If the exact frequency is not known or if you wish to scan the dial, turn the volume on your preamplifier/amplifier up slightly. When the dial pointer comes close to a station, one of the tuning indicators will light. Turn the tuning dial in the direction of the glowing indicator lamp until both tuning indicators are lit. This will indicate that the tuner is centered and locked on the station.

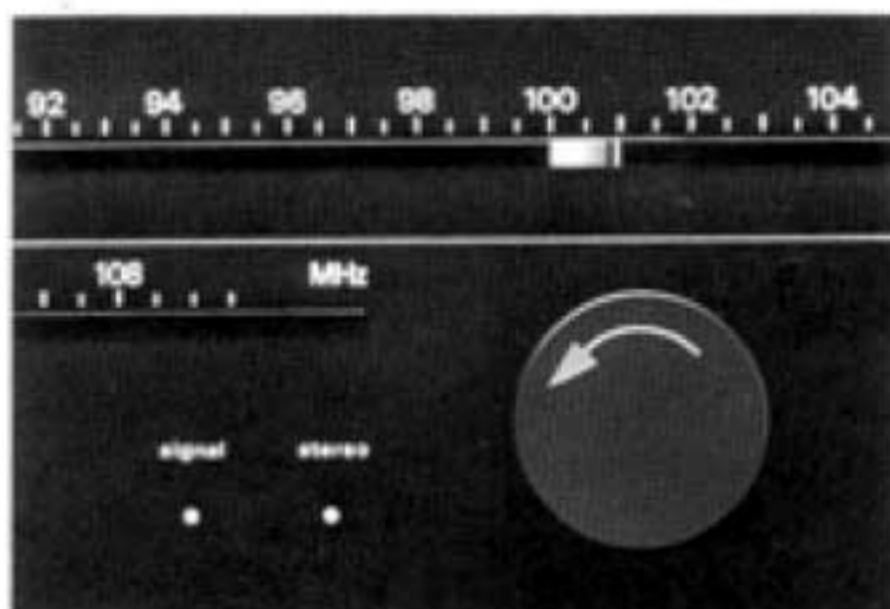
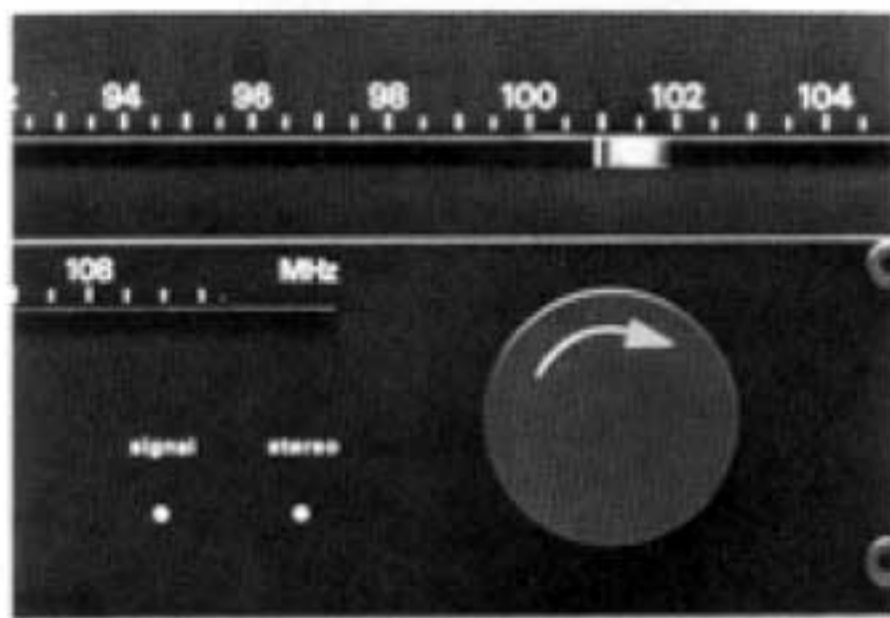

4. Gradually increase the volume control setting on your preamplifier/amplifier to the desired listening level.
5. Adjust the output level control on the 430 so that the sound level of the tuner is approximately equal to that of your turntable, tape deck, etc. This will prevent accidental sound "blasting" when you switch from one source to another.

Additional Function Switches and Indicators

Mono Switch

When this switch is depressed, the output signal of the 430 will be monaural, even if the selected station is broadcasting in stereo. The mono switch is particularly effective in improving the listenability of a very noisy FM stereo reception, although it does so at the expense of stereo separation.

Narrow Switch

This switch should normally be left in the "normal" or "wide" position (out) because this position yields the best distortion and separation performance. If, however, the presence of many stations crowded close together on the dial makes precise tuning difficult or impossible, the switch should be depressed to obtain "narrow" selectivity.

Dolby FM® Switch

Dolby FM broadcasts are becoming increasingly popular in many parts of the world. The 430 does not provide built-in Dolby Noise Reduction decoding circuitry, but the system is available as an optional plug-in accessory. If FM stations in your reception range are broadcasting Dolby FM, please consult your nearest Nakamichi dealer for further details.

NOTE: If the Dolby FM switch is depressed without the optional Dolby FM cir-

cuit board installed, there will be no signal at the 430's outputs.

Hi-Blend Switch

If background noise is objectionable because of weak signal strength, depress this switch to reduce the noise. Hi-blend does not affect frequency response; but it does reduce stereo separation at the high frequencies. If hi-blend fails to produce a listenable signal, depressing the mono switch should further reduce background noise.

Muting Switch

Interstation muting eliminates all the "garbage" in between FM stations. Since muting is automatically de-activated when the tuner is centered on a station, the switch can be left on (in) at all times.

Signal Indicator

When this indicator glows, the tuner is receiving sufficient signal strength for optimum signal-to-noise ratio, separation and distortion. If this lamp does not glow after you have tuned to a desired station, try altering the antenna position. Regardless of antenna type or position, some stations will not be received with sufficient signal strength to light the signal indicator. These stations are generally transmitting a weak signal or are simply too far away, or both.

Stereo Indicator

This indicator lamp glows when you have selected a station broadcasting in FM Stereo. Depressing the mono switch will prevent this indicator from glowing, even though the selected station may be broadcasting in stereo.

Multipath Output Jacks

A Brief Explanation of Dolby FM
FM stereo has always been a relatively noisy medium, requiring a rather sharp preemphasis (boosting of high frequencies) at the transmitter and a complementary de-emphasis (restoration of pre-boostered highs) at the tuner or receiver to achieve a reasonable semblance of noise-free performance. The 75 microsecond time constant (50 microseconds in most European countries) defines the standard preemphasis curves currently being used by non-Dolbyized FM stations. The drawback of so much pre-emphasis is that stations must utilize large amounts of high-frequency limiting to prevent overmodulation, or else modulate at an overall lower level and end up with what the pre-emphasis was supposed to counter in the first place: poor signal-to-noise ratio. This is why even the best of FM broadcasts have lacked the dynamic range of today's better quality LP discs, especially at the higher frequencies. Dolby FM improves the quality of reception in two basic ways (assuming the station is broadcasting Dolby FM):

- a) better signal-to-noise ratio, especially in weak signal areas;
- b) full recovery of high frequency dynamic range in any reception area.

The increase in signal-to-noise is the result of the well-known properties of the Dolby Noise Reduction System. Dolby FM utilizes the same B-type Dolby circuitry found today on numerous cassette tape recorders. The increase in high frequency dynamic range can be attributed to a new FM time constant, 25 microseconds. FM stations broadcasting Dolby FM utilize this new time constant which reduces pre-emphasis to an optimum level. High frequency over-modulation and the need for drastic limiting are eliminated. If the optional Dolby FM plug-in board has been installed, depressing the Dolby FM switch on the Nakamichi 430 changes the de-emphasis time constant

to 25 microseconds as well as activating the built-in Dolby Noise Reduction System. If stations in your area are broadcasting a high quality Dolby FM signal, you will notice a distinct improvement in reception quality when you switch to Dolby FM on your 430.

Note: When recording a Dolby FM broadcast on your tape deck, depress the Dolby FM switch on the 430, if equipped with the optional Dolby FM plug-in board. Set levels and record the broadcast as you would any other program source (with the deck's Dolby System on, if provided).

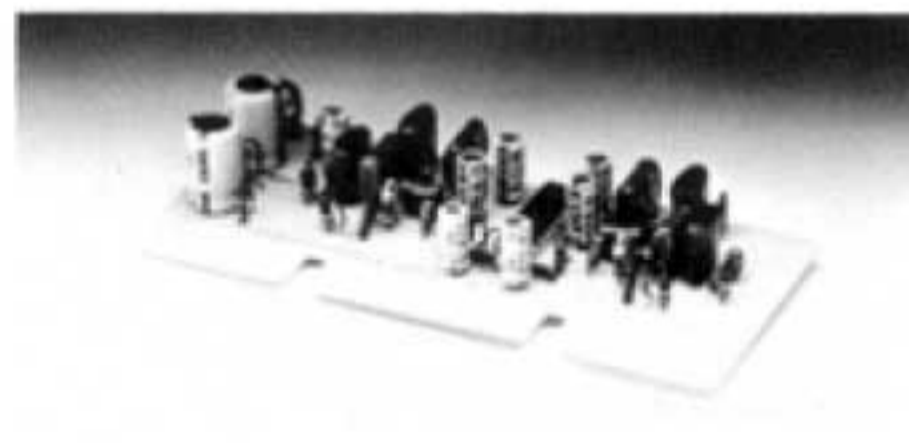

MULTIPATH OUTPUT JACKS

FM transmission is propagated through the air in a straight line, just like light. Multipath is caused by signal reflections from hills or tall structures near the FM tuner. Reflected signals arrive at the tuner perceptibly later in time than the direct broadcast signal, causing very annoying distortion, especially in FM stereo. In television, multipath is clearly observable as ghosting or color aberration, but in FM radio it is not always easy to detect its presence.

In order to obtain the best possible FM reception it is necessary to adjust the antenna height and direction for maximum signal strength and minimum multipath. The 430 provides multipath output jacks which can be used in either of two ways to aid in multipath-free reception.

1. Using an oscilloscope

Connect the "vert" jack of the 430 to the VERTICAL input of the oscilloscope. Similarly, connect the "horiz" jack to the HORIZONTAL input of the 'scope (set the 'scope for external sync. and "AC" input mode). Then,

- (a) tune in desired station and center properly using the tuning indicators and the signal indicator;
- (b) adjust the oscilloscope to display the multipath waveform;
- (c) Photograph A illustrates high multipath content. Photograph B shows no multipath, assuring the most distortion-free reception. Adjust your antenna to obtain the lowest possible multipath content.

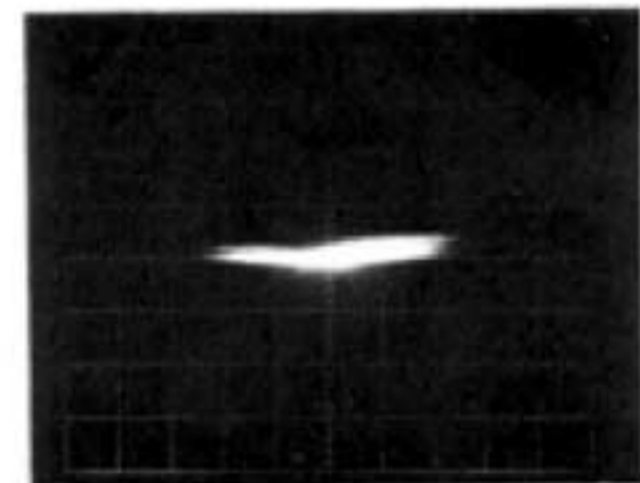

B

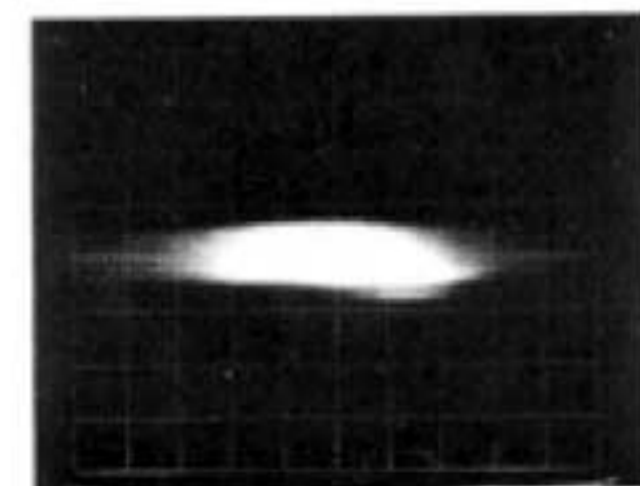

A

2. Using your ears

A high degree of accuracy can be achieved by simply listening for the least amount of multipath. To do this, connect either the "vert" or "horiz" multipath output jack to the auxiliary input of your preamplifier or integrated amplifier. Adjust your antenna while listening to the sound of the multipath signal (your pre-amplifier/amplifier should be set for "auxiliary", not "tuner"). The antenna position which yields the faintest sound is the position of least multipath.

Block Diagram / Specifications

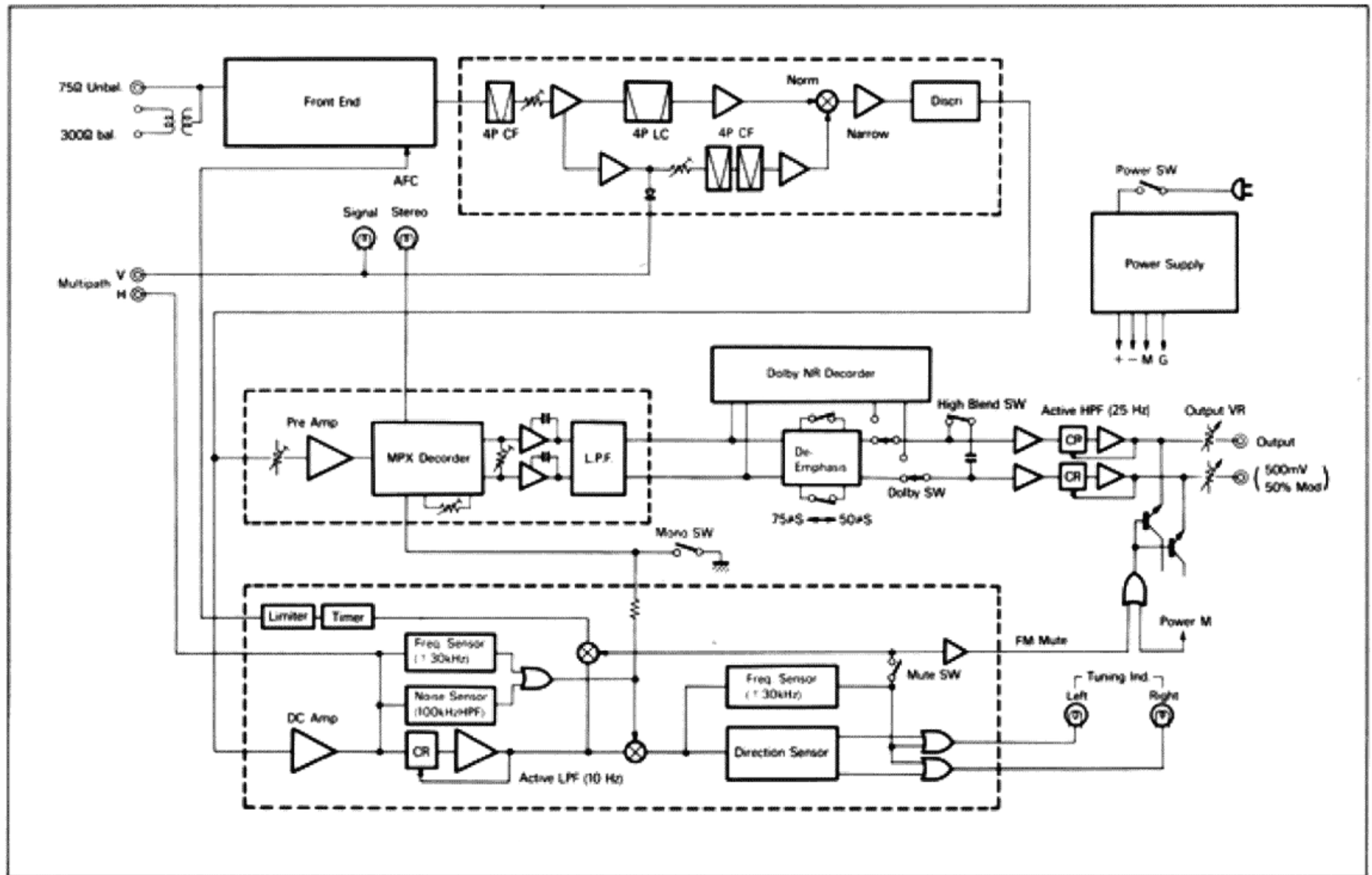

Specifications

Power Requirements	100 – 120/220 – 240VAC 50/60Hz	Alternate Channel Selectivity	normal better than 60dB narrow better than 90dB
Power Consumption	11VA	Stereo Separation	normal 100Hz – better than 35dB 1KHz – better than 50dB 10KHz – better than 35dB narrow 100Hz – better than 30dB 1KHz – better than 30dB 10KHz – better than 30dB
Frequency Band	88MHz – 108MHz	Spurious Response Rejection	better than 100dB
Usable Sensitivity (for 30dB quieting)	1.8μV (300 ohms) 10.5dBf	Image Rejection	better than 100dB
Sensitivity (for 50dB quieting)	mono – 4μV (300 ohms) 17.3dBf stereo – 40μV (300 ohms) 37.3dBf	IF Rejection	better than 100dB
Signal-to-Noise Ratio (@65dBf)	mono – better than 70dB stereo – better than 68dB	AM Suppression	better than 60dB
Muting Threshold	7.5μV (300 ohms) 23dBf	SCA Rejection	better than 75dB
Frequency Response	30 – 15,000Hz + 0.5, – 1.5dB	Frequency Drift	less than 30KHz, –10° to 60° C
Distortion (@65dBf, 100% modulation)	1KHz normal mono – less than 0.06% stereo – less than 0.09% narrow mono – less than 0.2% stereo – less than 0.4%	MPX Filter	–70dB @19KHz
Capture Ratio	normal 1.5dB narrow 4.0dB	Antenna	300 ohms balanced 75 ohms unbalanced
		Output Level	500mV (50% modulation, @output volume maximum)
		Dimensions	15-3/4(W) x 3-5/32(H) x 8-3/4(D) inches 400(W) x 80(H) x 222(D) m/m
		Weight	10.8 lb (approx.) 4.9 Kg

Performance Data

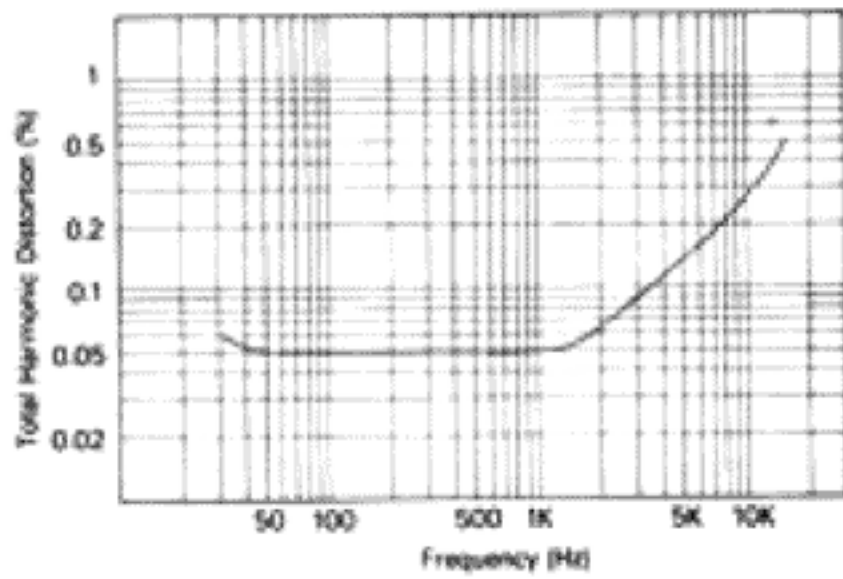

Frequency vs. Total Harmonic Distortion (Stereo)
 Modulation: main 45.5%
 sub-carrier 45.5%
 pilot 9%
 Antenna Input: 98 MHz, 65 dBf, 1mV, 300 Ohm

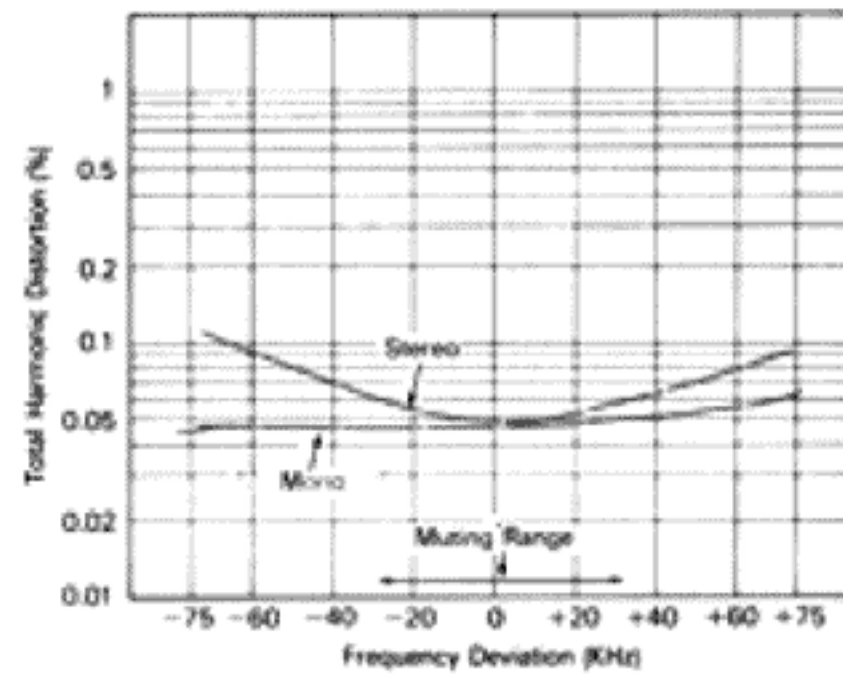

Frequency Deviation vs. Total Harmonic Distortion
 Antenna Input: 98MHz, 65dBf, 1mV, 300 Ohm
 Modulation: main 45.5%
 sub-carrier 45.5%
 pilot 9%
 AFC ON

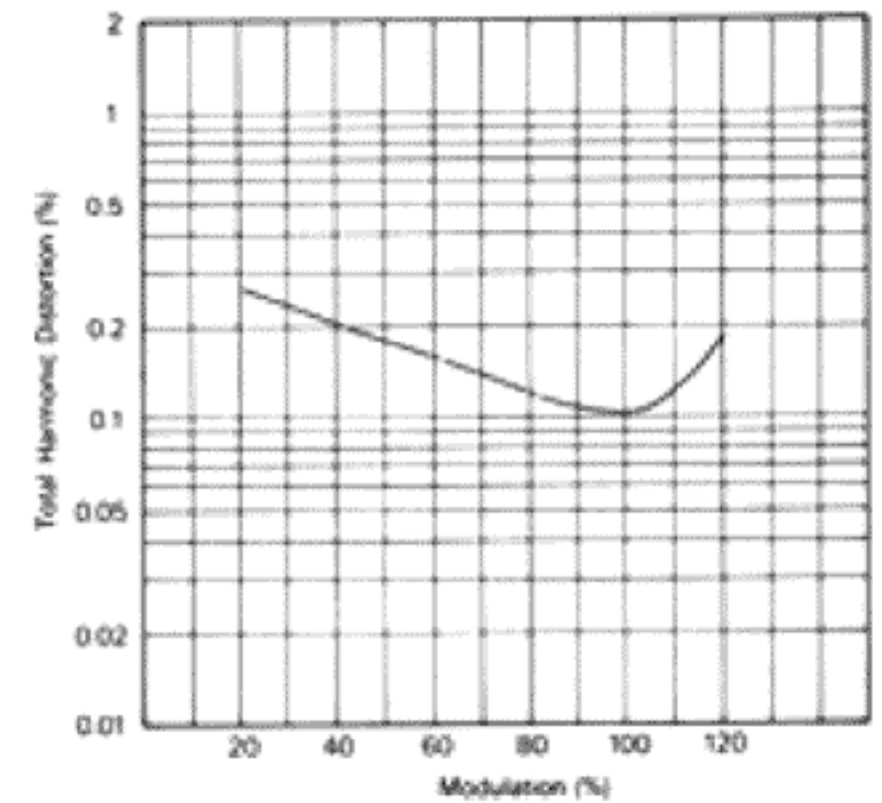

Modulation vs. Total Harmonic Distortion
 Modulation: main 45.5%
 sub-carrier 45.5%
 pilot 9%
 Frequency: 1 KHz
 Antenna Input: 98 MHz, 65 dBf, 1mV, 300 Ohm

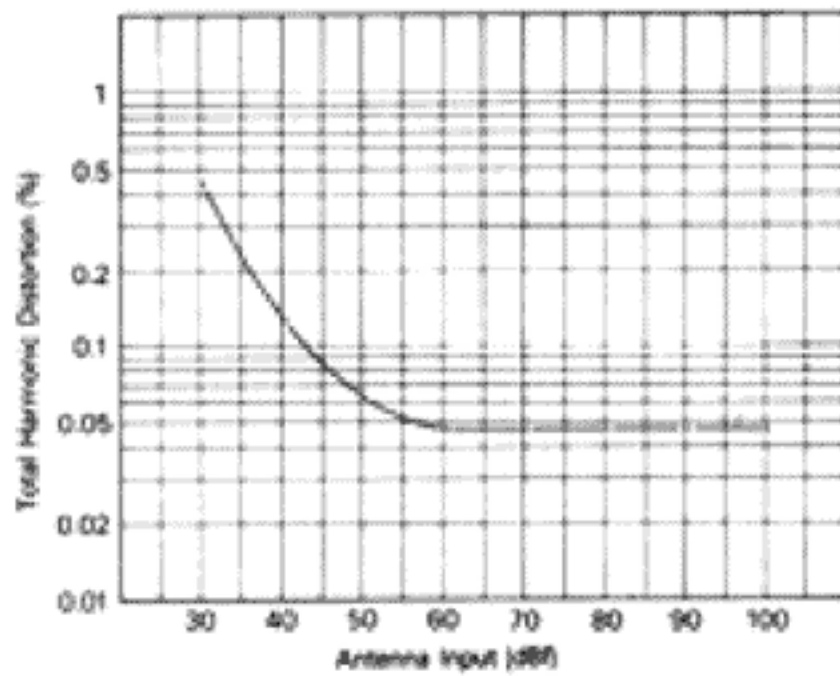

Input vs. Total Harmonic Distortion (Stereo)
 Modulation: main 45.5%
 sub-carrier 45.5%
 pilot 9%
 Frequency: 1 KHz

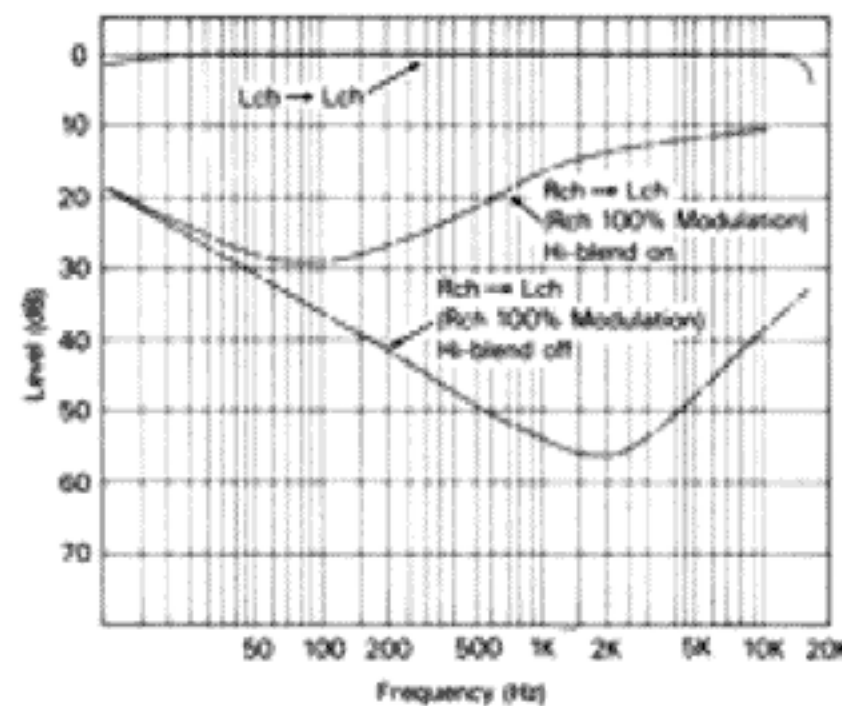

Stereo Separation
 Antenna Input: 98 MHz, 65 dBf, 1mV, 300 Ohm
 IF: Normal

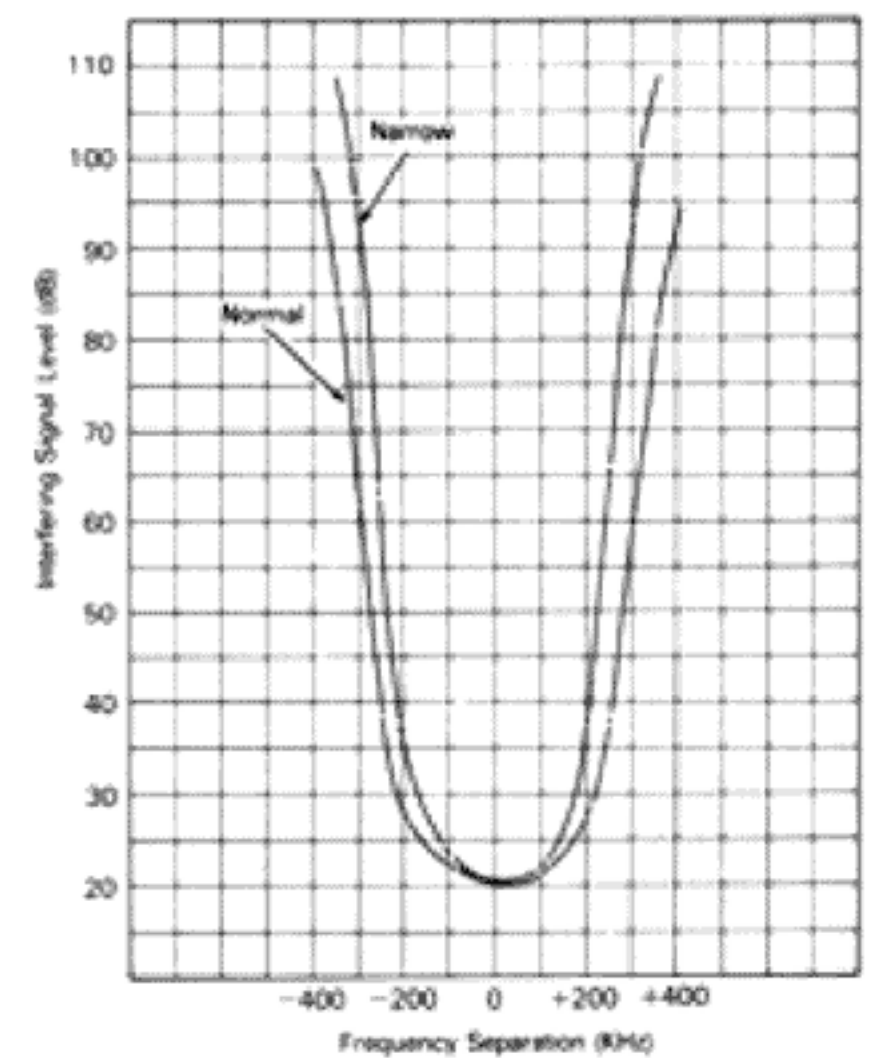

Selectivity
 Impedance: 300 Ohm
 Interfering Signal: 1 KHz 100% Modulation
 Interfering Output Level: -30 dB
 Desired Signal: unmodulated

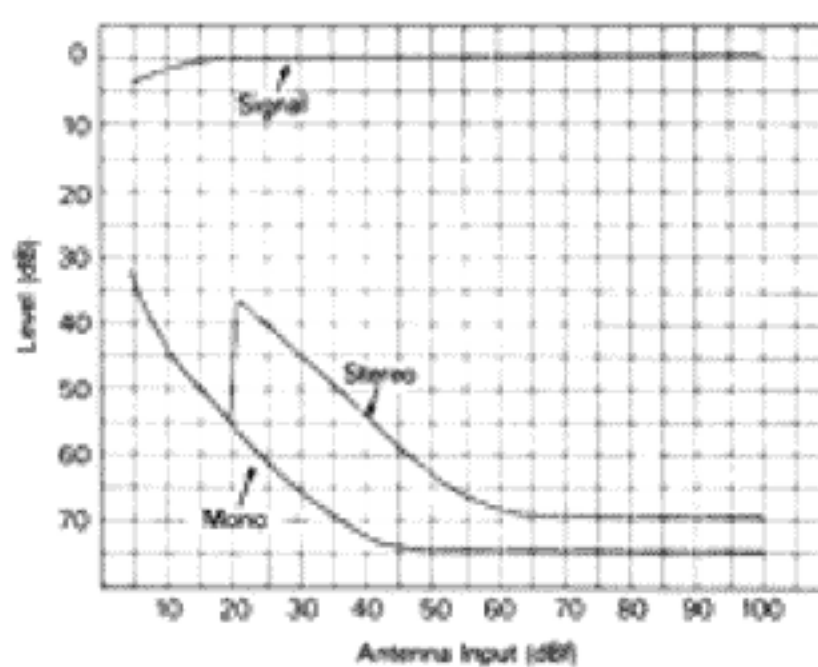

Antenna Input vs. Noise Level
 Frequency: 1 KHz

SERVICE INFORMATION

Although it is unlikely that your Nakamichi 430 will require repair, should servicing ever become necessary, please consult your Nakamichi dealer or the

Nakamichi dealer closest to you. As there are no user serviceable parts inside the unit, please do not attempt your own repairs.

Please read all accompanying Warranty Cards and/or notices very carefully. Thank you for your confidence in Nakamichi products.