



# FISHER

## K-1000

STEREOPHONIC

### 150-Watt Power Amplifier

OPERATING INSTRUCTIONS AND SERVICE MANUAL



## A Message From Avery Fisher

WITH your purchase of a FISHER instrument you have completed a chain of events that began many months ago, in our research laboratories. For it is there that the basic concept of the equipment you have just acquired came into being—its appearance, its functions, its quality of performance, its convenience of use.

But the end step—your purchase—is merely a beginning. A door has now opened, for you and your family, on virtually unlimited years of musical enjoyment. Recognizing that one of the keys to pleasurable ownership is reliability, we have designed this instrument to give long and trouble-free service. In fact, instruments we made over twenty-five years ago are still in use today.

Remember always that we want this equipment to give you the best performance of which it is capable. Should you at any time need our assistance toward that objective, please write me personally.

### AN IMPORTANT SUGGESTION

Many hours have been spent by our engineers and technical writers to create this instruction book for your guidance and enjoyment. If you want the *most* out of your FISHER, there is only one way to obtain it. With the equipment before you, please read this booklet carefully. It will be time well spent!

*Avery Fisher*

President, Fisher Radio Corporation

# THE FISHER K-1000

## STEREOPHONIC

### 150-Watt Power Amplifier



**Y**OU HAVE JUST BUILT the finest stereophonic power amplifier in existence. As you wired the *K-1000*, you no doubt noticed the uncluttered, orderly layout and the high quality of the parts used, such as mylar capacitors, low-noise high-accuracy deposited carbon resistors and military-type terminal boards. But this is only part

of the story behind the *K-1000*. Even more important is the fact that the *K-1000* is a new design, not simply an adaptation or modification of existing designs. It is the result of a research project by the Fisher Laboratories in which the main objective was to take a fresh look at the problems of music reproduction and to determine if new techniques, materials and developments in other fields of electronics could be harnessed to the art of high fidelity music reproduction. The basic goal was to break out of the narrow circle of existing designs, used by practically all manufacturers—designs which in one form or another have been the stock-in-trade of the industry for many years. This selective, careful search by our research staff has resulted in the amplifier you now own. Both in its outward appearance and its inner design, it represents a new advance in the high fidelity field and is destined to take its place as the industry standard for many years to come.

This new look is exemplified by practically every detail of the *K-1000* design. For example, the input circuit of conventional amplifiers has long been neglected by audio engineers. The result of this neglect is generally an unimaginative triode voltage amplifier preceded by a continuously variable level control potentiometer. This approach, while adequate, does not take advantage of the extremely broad-band characteristics of other circuits and simply disregards the well-known fact that continuously variable input level controls cause high frequency roll-off when used to attenuate the input signal. The Fisher design is quite different. It is similar to the design used in laboratory oscilloscopes incorporating an extremely wide-band cathode-follower and a step-type attenuator that is completely compensated to prevent high frequency roll-off, regardless of the setting used. In addition, a new type of tube was used, specifically developed for low-noise input stages of audio amplifiers and incorporating a built-in shield for maximum channel isolation.

The pre-driver and phase inverter utilizes a DC-coupled Cathodyne configuration. This circuit is completely self-balancing, despite tube aging and produces negligible distortion within its operating range. Direct coupling from the pre-driver to the phase inverter assures minimum phase shift and an extended low frequency response. A feedback loop of 17 db from the secondary of the output transformer reduces distortion in the pre-driver, phase-inverter and driver stages to the vanishing point—without causing incipient instability and ringing resulting from excessive use of feedback.

Another example of the novel design of the *K-1000* is the driver stage, using push-pull pentodes in a completely new circuit. These pentodes, often used in low-power amplifiers as the output stage, contribute greatly to the unequalled performance of the *K-1000*. Because

they are operated well below their maximum ratings (40%, to be exact) and have inherently low output impedance and extremely rapid recovery time, these pentode drivers are largely responsible for the *K-1000's* superior transient response.

To obtain the best performance from the output stage, Fisher Laboratories had a new type of tube designed to its specifications. This tube, never before used in any electronic device, offers extreme linearity over a very wide range. Its high sensitivity permits the preceding stages to operate at lower voltage (and, therefore, lower distortion) levels. The output transformers are custom-wound to rigid Fisher specifications and have a flat response from 5 to 200,000 cps with an extremely smooth roll-off above and below these frequencies. The output circuit itself utilizes place-cathode coupling for an additional 12 db of feedback to reduce distortion without the phase shift and instability normally associated with one loop of high over-all feedback.

In order to match the high quality of the audio circuits, an unusually elaborate power supply was developed, using silicon diodes throughout to improve regulation, provide trouble-free service and reduce heat dissipation. Three completely independent low-impedance power supplies are provided for the plate, screen-grid and control-grid voltages of the output tubes. Military-type terminal board construction and the highest quality, conservatively rated components assure many years of service. Bias and balance adjustments and a built-in meter and meter switch make it possible to check the performance of the *K-1000* quickly and accurately.

The *K-1000* is also the first high power stereo amplifier that is gracefully and attractively styled for mounting on an open shelf or table. All input and output connections are on the rear panel, and the infrequently used bias and balance adjustments are hidden by a hinged panel. The architectural brass-toned front panel is designed to match the current line of Fisher components and is a welcome departure from other power amplifiers which must be kept out of sight because of their ungainly appearance.

As a result of the care and attention to detail that went into your *K-1000*, it performs its function—to produce an amplified exact replica of the original signal—quietly, efficiently and effortlessly. With reasonable care, it will continue to do so for many years to come.

### INSTALLING THE K-1000

**T**HE *K-1000* OPERATES on 105-120 volts, 50-60 cycles (AC) only. It can be placed in any convenient location, on a horizontal surface, providing that adequate ventilation is available. At least four inches above, and two inches to all three sides of the *K-1000* should be left open for the circulation of air. The *K-1000* should never be installed in an enclosed space, or placed above other heat-producing equipment. Due to its attractive styling and the location of all input and output connections on the rear panel, the *K-1000* can be placed on an open shelf or table. It can also be placed out of sight or in a remote location, since it has no operating controls which require frequent resetting.

## Loudspeakers

Placement of loudspeakers has a significant effect on the sound quality of a high fidelity system. Most speakers will give better results in the bass range when placed in a corner, although there are exceptions to this rule. Speakers should generally be placed along a wall in such a position that no large objects block the sound path between the speakers and the listening area. In a stereo system the speakers should be approximately equidistant from the listening area. As a rule-of-thumb, the distance between the speakers should be approximately two-thirds the distance separating the speakers from the listening area. It has been found that the aural effect of stereophonic sound is enhanced when two identical speaker systems are used. Although these principles can serve as a general starting point in placing your loudspeakers, we strongly recommend that you experiment with several different arrangements before deciding on a final placement. The unpredictable effects resulting from furniture arrangement and irregularities in room dimensions may sometimes make unorthodox placement of the loudspeakers necessary.

After the initial location of the loudspeakers has been decided upon, make the following connections:

**ONE SPEAKER:** If you are using only one speaker, it should be connected to the LEFT SPEAKER terminal strip on the rear panel. (See Figure 1.) One lead should be connected to the terminal lug marked C and the other to the terminal which matches the impedance of your loudspeaker. Use ordinary power cord, up to 50 feet in length, for these connections. For longer distances, use heavy-duty wire. Use of ordinary, thin "speaker wire" is definitely not recommended because of its relatively high resistance. *The Right Channel Input Attenuator should be turned to the OFF position, and left in this position until a speaker is connected to the RIGHT SPEAKER terminals.*

**TWO SPEAKERS:** Normally, the speaker system to your left (as viewed from the listening area) should be connected to the LEFT SPEAKER terminal strip and the speaker system to your right should be connected to the RIGHT SPEAKER terminals. In each case, the terminal on the K-1000 marked C should be connected to the ground or common terminal (marked G, GND, C, COM, etc.) of your loudspeaker. This will assure correct phasing of your loudspeakers, causing the speaker cones to move back and forth in unison, rather than in opposition. Use ordinary power cord for distances up to 50 feet, heavy-duty power cord for longer distances. Ordinary, thin "speaker wire" is definitely not recommended because of its relatively high resistance. The other lead from the loudspeaker should be connected to the "4," "8," or "16" terminal, depending on the impedance of your loudspeaker.

## Public Address System Application

For use in a 25-volt constant voltage public address system, connect line to the 16-ohm taps for applications requiring up to 40 watts per channel. Connect line to 8-ohm taps for applications requiring up to 65 watts per channel.

## Input Connections

Two sets of inputs are provided on the rear panel for the connection of preamplifier-control units, tape recorders, tuners or other signal sources with a minimum output voltage of 0.5 volt (to obtain full rated output). Connections should be made with shielded audio cables, tipped with standard RETMA phono plugs. Two identical inputs for each channel are provided as an added convenience.

## AC Power Connections

The K-1000 should be connected to a source providing 105-120 volts at 50-60 cycles. The K-1000 has been designed for use in conjunction with a preamplifier-master audio control having a switched AC convenience outlet. When the power cord from the K-1000 is connected to such an outlet, you will be able to turn power on and off to both the preamplifier and the K-1000 by operating the power switch on the preamplifier. Do not connect the power cord to an unswitched wall outlet since there is no power switch on the K-1000. While the maximum power consumption of the K-1000 is 400 watts, it draws only 170 watts when there is no input signal. Therefore, in

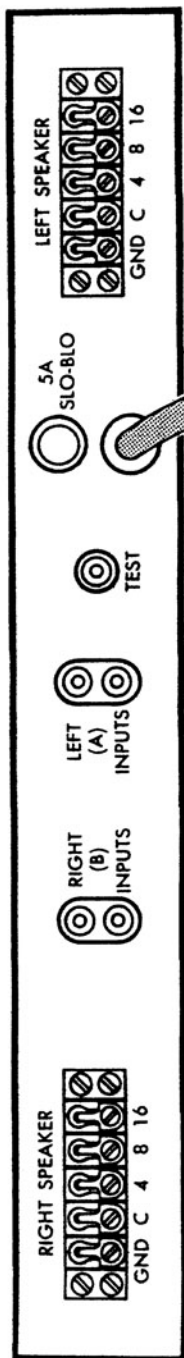

FIGURE 1. Rear panel.

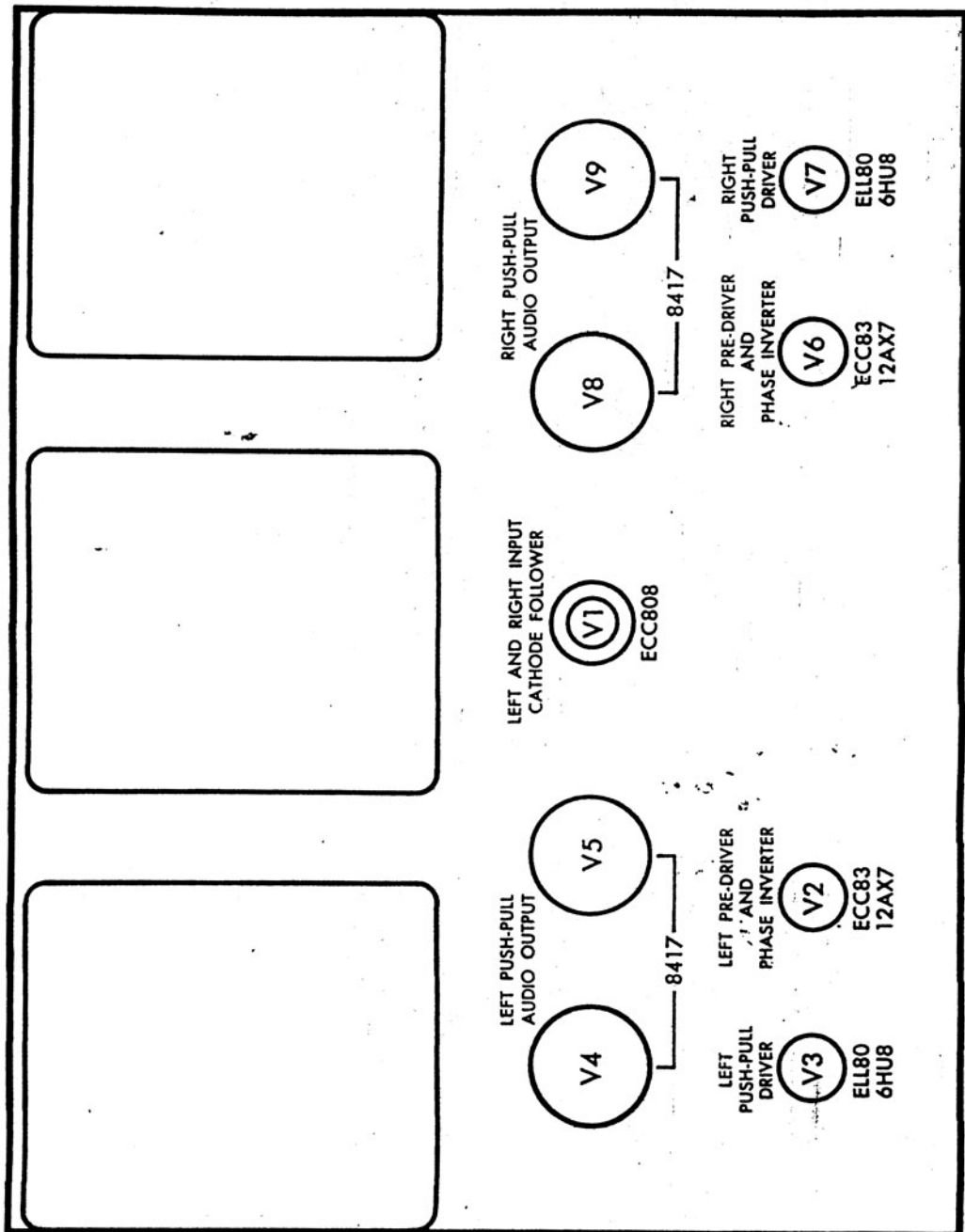
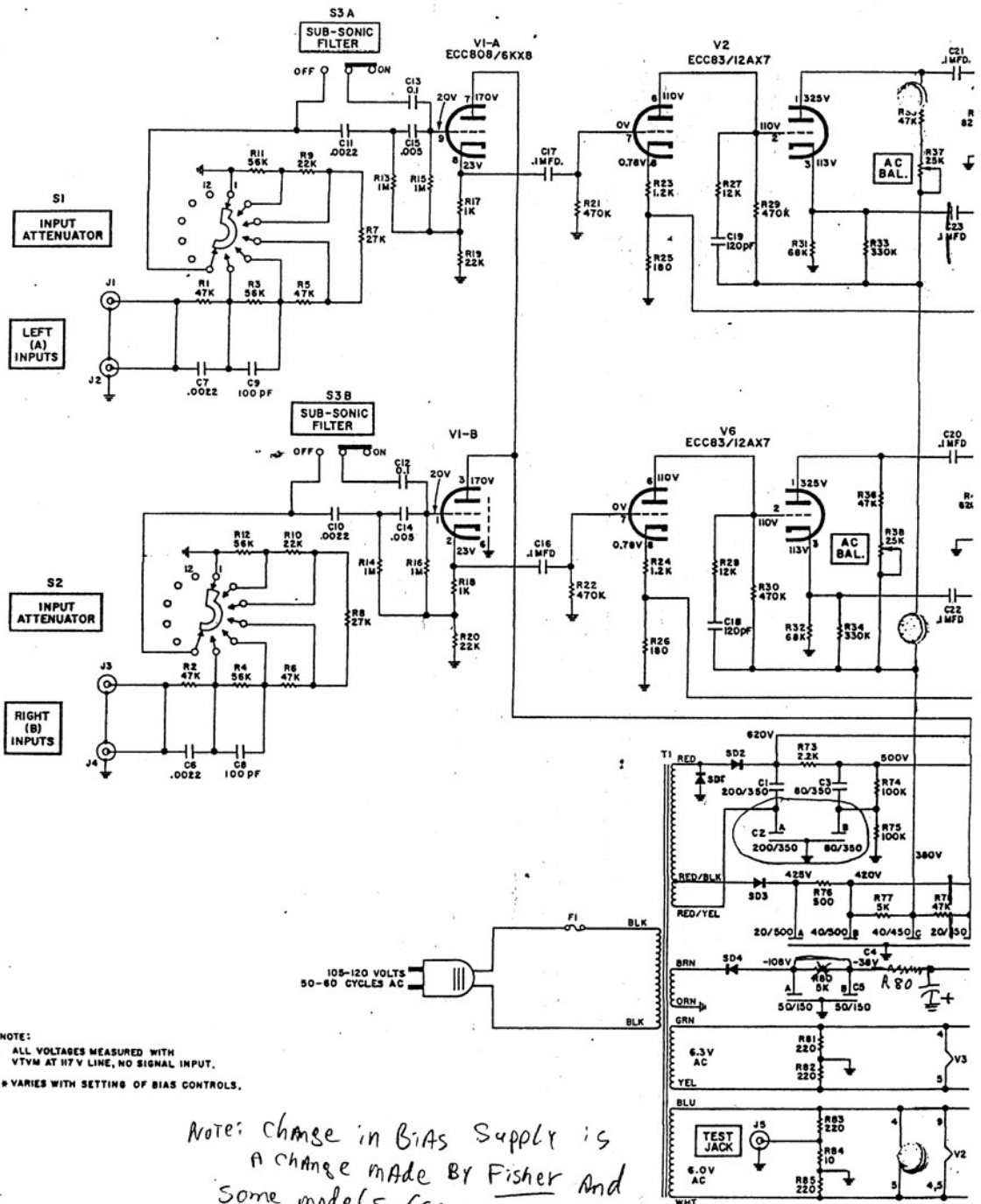
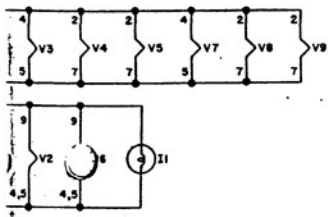
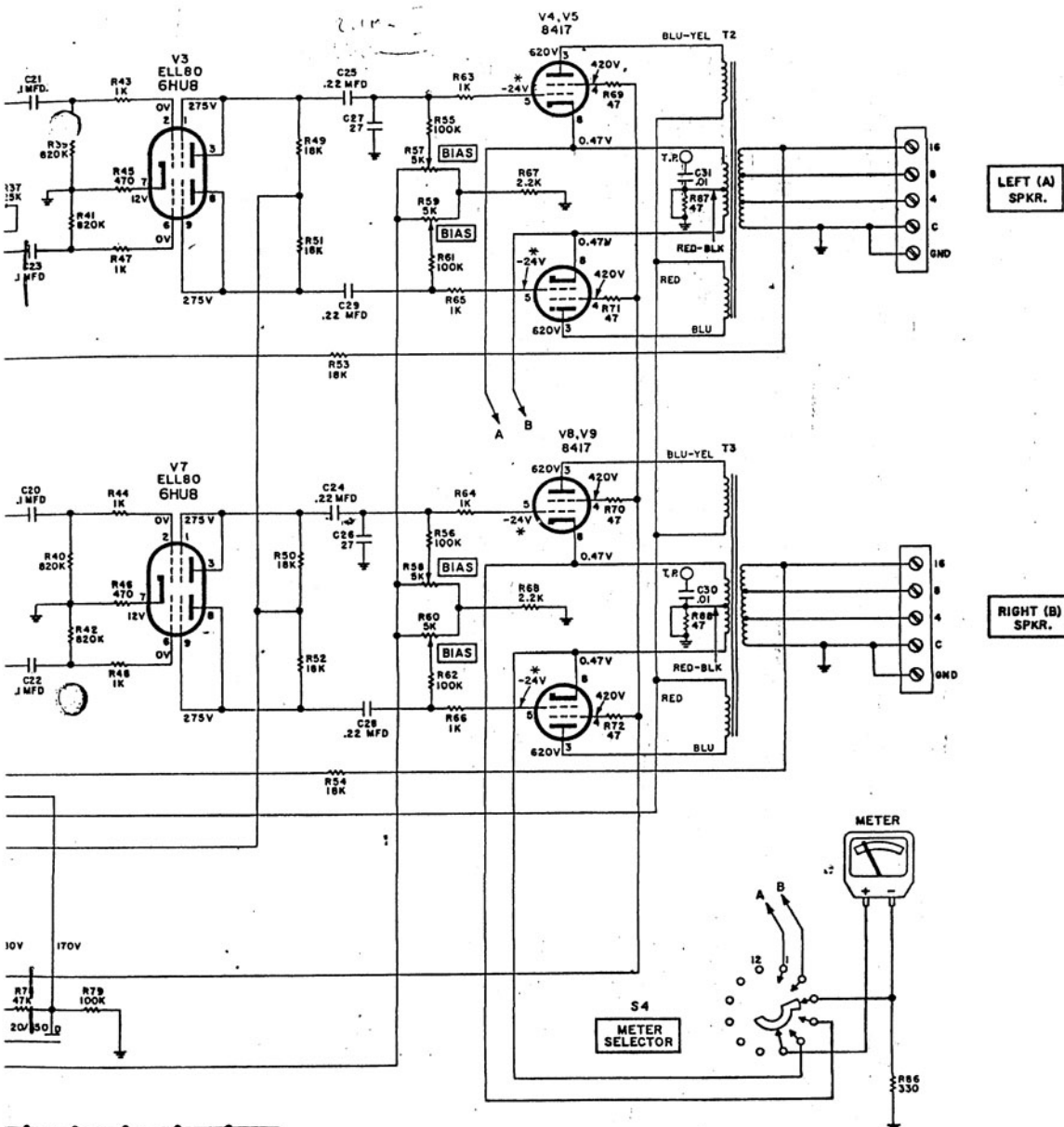

FIGURE 2. Tube layout of the K-1000.



NOTE:  
 1. ALL VOLTAGES MEASURED WITH VTVM AT 87 V LINE, NO SIGNAL INPUT.  
 2. \* VARIES WITH SETTING OF BIAS CONTROLS.

NOTE: change in Bias Supply is a change made by Fisher and some models (SA-1000 us 44C) have this change already made.



SWITCH POSITIONS			
POS. NO.	S1 AND S2 INPUT ATTENUATORS	S4 METER SELECTOR	
1	OFF (SHOWN)	BIAS V4	
2	-12 DB	BIAS V5	
3	-9 DB	OFF (SHOWN)	
4	-6 DB	BIAS V8	
5	-3 DB	BIAS V9	
6	-0 DB		

LAST  
R88 C31

order to avoid the possibility of exceeding the maximum rating of your preamplifier On-Off switch, we strongly recommend that you turn the Volume control to minimum before turning your set off. Of course, this will occur automatically if your preamplifier On-Off switch is integrated with the Volume control.

### System Grounding

Two convenient ground terminals (marked GND) are provided on the rear panel for grounding your record player in order to reduce possible hum. The chassis ground of other components may also be connected to these terminals if desired.

## OPERATING THE K-1000

### Setting the Input Attenuators

The Input Attenuators are stepped (in 3 db increments) in order to provide precise frequency compensation for all settings. Regardless of the setting used, they will not cause high frequency roll-off, as do ordinary, continuous input level controls. The OFF position shorts the input to ground, and should be used only when aligning the K-1000 (or when using a single speaker, as explained on page 2). The attenuators provide from 0 to 12 db of attenuation for each channel separately. They should be used to equalize the sound output from both channels, and to permit "comfortable" listening levels with the preamplifier volume control at approximately the "12 o'clock" position. To adjust for equal levels from both channels, play a monophonic record with the Mode Selector on your preamplifier at STEREO and the Balance control at the center position. You can then adjust the Input Attenuators (starting with both at the -12 DB position) to compensate for inequalities in the preamplifier outputs or differences in speaker sound levels caused by room acoustics, placement of the speakers, or use of two different types of speaker systems for the two channels. (The two channels of the K-1000 itself do not differ in gain by more than 1 db.)

### Subsonic Filter

A subsonic filter has been provided to prevent speaker damage or overloading as a result of turntable rumble, off-center records and similar low-frequency noise sources. This filter provides a steep roll-off below the audible range (below 16 cps), and will not, therefore, cause any detectable difference in the sound output. The Subsonic Filter switch should generally be left ON as added security against possible low frequency noise in the program source. The OFF position provides a flat frequency response (within 1 db) down to 8 cps.

## SERVICE NOTES

### Bias Adjustment

The Bias settings should be checked occasionally and whenever an output tube is replaced. This is done in the following manner:

- 1—Set both Input Attenuators to OFF.
- 2—Open the hinged control cover.
- 3—Turn the Meter Selector alternately to each position and adjust the appropriate Bias control for a meter pointer indication in the BIAS band on the meter scale.

NOTE: Slight flickering of the pointer is normal. Meter readings obtained during the initial break-in period of the tubes and during the first 20 minutes of operation each time the amplifier is turned on will vary considerably in most cases. This should be no cause for concern since the meter and the meter circuit have been designed to be extremely sensitive to small changes in the measured voltages. Apparently large variations in meter readings are all well within the normal operating range of the output tubes. To avoid damage to the meter, do not take meter readings until both Input Attenuators have been turned to the OFF position.

### AC Balance Adjustment

The AC Balance adjustment can be carried out in two ways. The first way is to use the Fisher STRATABALANCE system as described in

Stage 27 of the Assembly Manual. If, however, you have the use of an IM distortion analyzer, you may wish to make the AC balance adjustment as described below.

**EQUIPMENT REQUIRED:** IM distortion analyzer; non-inductive load resistor (minimum 100-watt rating) of either 4, 8, or 16 ohms.

### RIGHT CHANNEL:

- 1—Connect the load resistor to the RIGHT SPEAKER terminals, using C and the appropriate terminal to match impedances.
- 2—Connect the IM distortion analyzer output to one of the RIGHT INPUT jacks.
- 3—Connect the analyzer input leads to the load resistor leads.
- 4—Rotate the Right Channel Input Attenuator switch to -0 DB.
- 5—Adjust the analyzer for the following specified voltages across the load resistor:

16-ohm load	— 26.4 volts
8-ohm load	— 18.7 volts
4-ohm load	— 13.2 volts

- 6—Adjust the RIGHT CHANNEL AC BAL control for minimum IM distortion.

### LEFT CHANNEL:

Follow the above procedure using the LEFT SPEAKER terminals, LEFT INPUT jacks, and LEFT CHANNEL AC BAL control.

### Replacing the Power Light

To replace the front panel power indicator light, simply remove the three knobs by pulling outward, and remove the two screws on the ends of the brass panel under the hinged cover. After the brass front panel is removed, the bulb can be detached from the holder by turning the bulb counterclockwise and then pulling outward. The bulb is a GE Type 47-OF (outside frosted) and can be obtained from your Fisher Dealer (Part No. IS0009-4).

## TECHNICAL SPECIFICATIONS

Music Power Output (IHFM standards, both channels)	150 watts
Harmonic Distortion (at IHFM rated output, 1 kc)	0.25%
RMS Power Rating (at 0.25% THD, 1 kc, both channels)	130 watts
IM Distortion (60/7000 cps, 4:1, of RMS rated output)	0.4%
Frequency Response	20-20,000 cps $\pm$ 0.5 db 8-50,000 cps $\pm$ 1 db
Power Bandwidth (IHFM, at rated distortion)	11-50,000 cps
Hum and Noise (below RMS rated output)	90 db
Sensitivity (for full rated RMS output) Maximum (at 0 DB position) With 3db step attenuator	0.5 volt 0.5-2.0 volts
Damping Factor (16-ohm taps)	17
Output Impedances	4, 8, 16 ohms
Input Impedance	250K ohms
Weight	71 pounds
Dimensions	15 1/2" wide 7 3/4" high (without plastic feet) 12" deep (without knobs)
Power Connection	105-120V, 50-60 cps
Power Consumption (at 117V, 60 cps) No input signal At rated RMS output	170 watts 400 watts



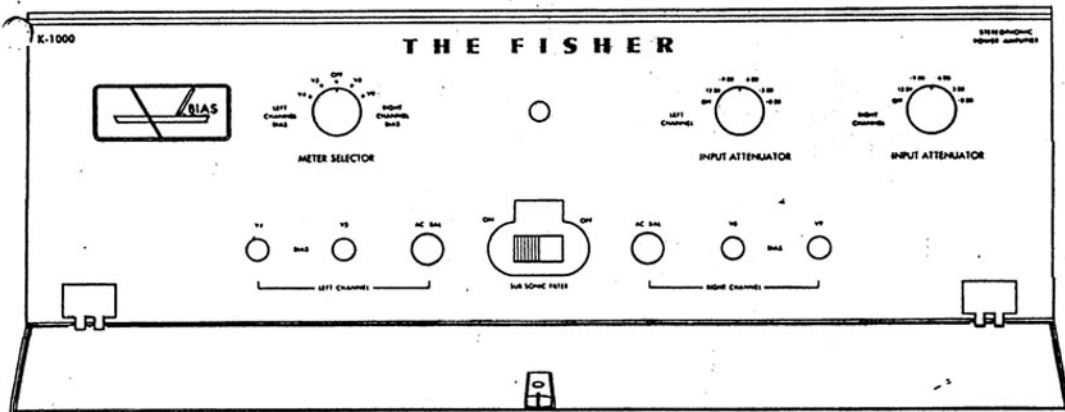

FIGURE 4. Front panel.

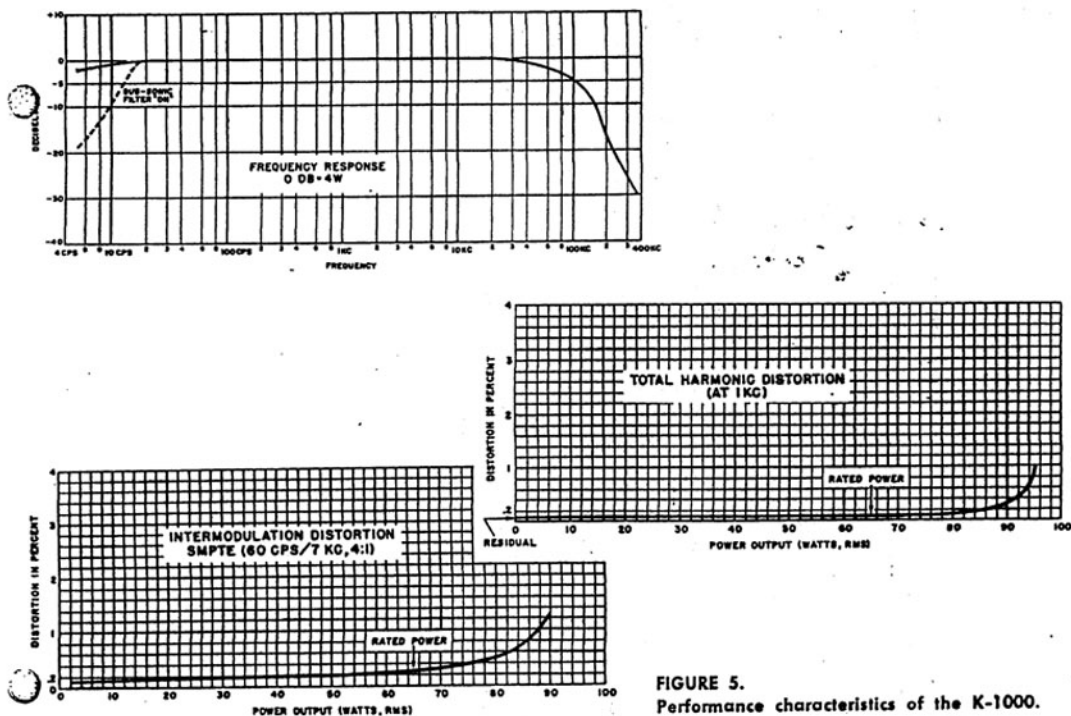

FIGURE 5.  
Performance characteristics of the K-1000.

## PARTS LIST

### CAPACITORS

10% tolerance for all fixed capacitors, unless otherwise noted or marked GMY (guaranteed minimum value): All capacitors not marked  $\mu$ f are pF ( $\mu$ uf).

Symbol	Description	Part No.
C1	Electrolytic, 200uf, 350V	C50180-52
C2	Electrolytic, 2 Section, A—200uf, 350V B—80uf, 350V	C50180-54
C3	Electrolytic, 80uf, 350V	C50180-53
C4	Electrolytic, 4 Section, A—20uf, 500V B—40uf, 500V C—40uf, 450V D—20uf, 350V	C50180-55
C5	Electrolytic, 2 Section, A—50uf, 150V B—50uf, 150V	C50180-57
C6, 7	Ceramic, 2200, 10%, 1000V	C50072-5
C8, 9	Ceramic, 100, N1500, 1000V	C50070-6
C10, 11	Ceramic, 2200, 10%, 1000V	C50072-5
C12, 13	Mylar, .1uf, 250V	C50197-54
C14, 15	Ceramic, 5000, 20%, 500V	C50089-1
C16, 17	Mylar, .1uf, 250V	C50197-54
C18, 19	Ceramic, 120, 5%, N1500, 1000V	C50070-44
C20, 21, 22, 23	Mylar, .1uf, 400V	C50197-32
C24, 25	Mylar, .22uf, 600V	C50197-100
C26, 27	Ceramic, 27, 10%, 1000V	C50070-10
C28, 29	Mylar, .22uf, 600V	C50197-100
C30, 31	Ceramic, .01uf, 500V	C50089-7

### RESISTORS

In ohms, 5% tolerance, 1/2 Watt unless otherwise noted.  
K = Kilohms, M = Megohms

Symbol	Description	Part No.
R1, 2	Dep. Carbon, 47K	R33DC473J
R3, 4	Dep. Carbon, 56K	R33DC563J
R5, 6	Dep. Carbon, 47K	R33DC473J
R7, 8	Dep. Carbon, 27K	R33DC273J
R9, 10	Dep. Carbon, 22K	R33DC223J
R11, 12	Dep. Carbon, 56K	R33DC563J
R13, 14, 15, 16	Dep. Carbon, 1M	R33DC105J
R17, 18	Dep. Carbon, 1K	R33DC102J
R19, 20	Dep. Carbon, 22K	R33DC223J
R21, 22	Dep. Carbon, 470K	R33DC474J
R23, 24	Dep. Carbon, 1.2K	R33DC122J
R25, 26	Composition, 180, 1/2 W	RC20BF181J
R27, 28	Dep. Carbon, 12K	R33DC123J
R29, 30	Dep. Carbon, 470K	R33DC474J
R31, 32	Composition, 68K, 10%, 1/2 W	RC20BF683K

R33, 34	Dep. Carbon, 330K	R33DC334J
R35, 36	Composition, 47K, 10%, 1/2 W	RC20BF473K
R37, 38	Potentiometer, 25K, AC Balance	R50103-2
R39, 40, 41, 42	Dep. Carbon, 820K	R33DC824J
R43, 44	Dep. Carbon, 1K	R33DC102J
R45, 46	Composition, 470, 10%, 1W	RC30BF471K
R47, 48	Dep. Carbon, 1K	R33DC102J
R49, 50, 51, 52	Glass, 18K, 10%, 5W	RP65W183K
R53, 54	Composition, 18K, 1/2 W	RC20BF183J
R55, 56	Dep. Carbon, 100K	R33DC104J
R57, 58, 59, 60	Potentiometer, 5K	R50103-4
R61, 62	Dep. Carbon, 100K	R33DC104J
R63, 64, 65, 66	Dep. Carbon, 1K	R33DC102J
R67, 68	Composition, 1.8K, 10%, 1/2 W	RC20BF182K
R69, 70, 71, 72	Composition, 18K, 1/2 W	RC20BF470K
R73	Wirewound, 2.2K, 10%, 10W	R858-127
R74, 75	Composition, 100K, 10%, 2W	RC40BF104K
R76	Glass, 500, 10%, 5W	RP65W501K
R77	Glass, 5K, 10%, 5W	RP65W502K
R78	Composition, 47K, 10%, 1W	RC30BF473K
R79	Composition, 100K, 10%, 2W	RC40BF104K
R80	Glass, 5K, 10%, 3W	RP63W502K
R81, 82, 83	Composition, 220, 10%, 1/2 W	RC20BF221K
R84	Composition, 10, 10%, 1/2 W	RC20BF100K
R85	Composition, 220, 10%, 1/2 W	RC20BF221K
R86	Composition, 330, 1/2 W	RC20BF331K
R87, 88	Composition, 47, 10%, 1/2 W	RC20BF470K

### MISCELLANEOUS

F1	Fuse, 5A, Slo-Blo	F581-136
I1	Pilot Lamp, #47 OF	150009-4
S1, 2	Switch, Input Attenuator	S858-112
S3	Switch, Slide, Sub-sonic Filter	S50200-5
S4	Switch, Meleg. Selector	S858-111
SD 1, 2, 3	Silicon Diode	SR50482-1
SD4	Silicon Diode	SR50411-1
TB1	Terminal Board	AS858-125
TB2, 3	Terminal Board	AS858-123
TB4	Terminal Board	AS858-124
T1	Transformer, Power	T858-115
T2, 3	Transformer, Output	T858-116
—	Meter	M858-107
—	Dress Panel	AS1067-108
—	Speaker Terminal Block	E50170-5
—	Knob	E50325-1
—	Jewel, Red	150162-1
—	Fuse Holder	X563-151

### STRATA-BALANCE PARTS

—	Lamp socket	X1067-110
—	Lamp, #47, clear	150009-1
—	Resistor, composition, 12K, 10%, 1/2 W	RC20BF123K
—	Phono-plug jumper, single	AS1067-115
—	Phono-plug jumper, double	AS50470-4
—	Dress Panel	AS1067-108

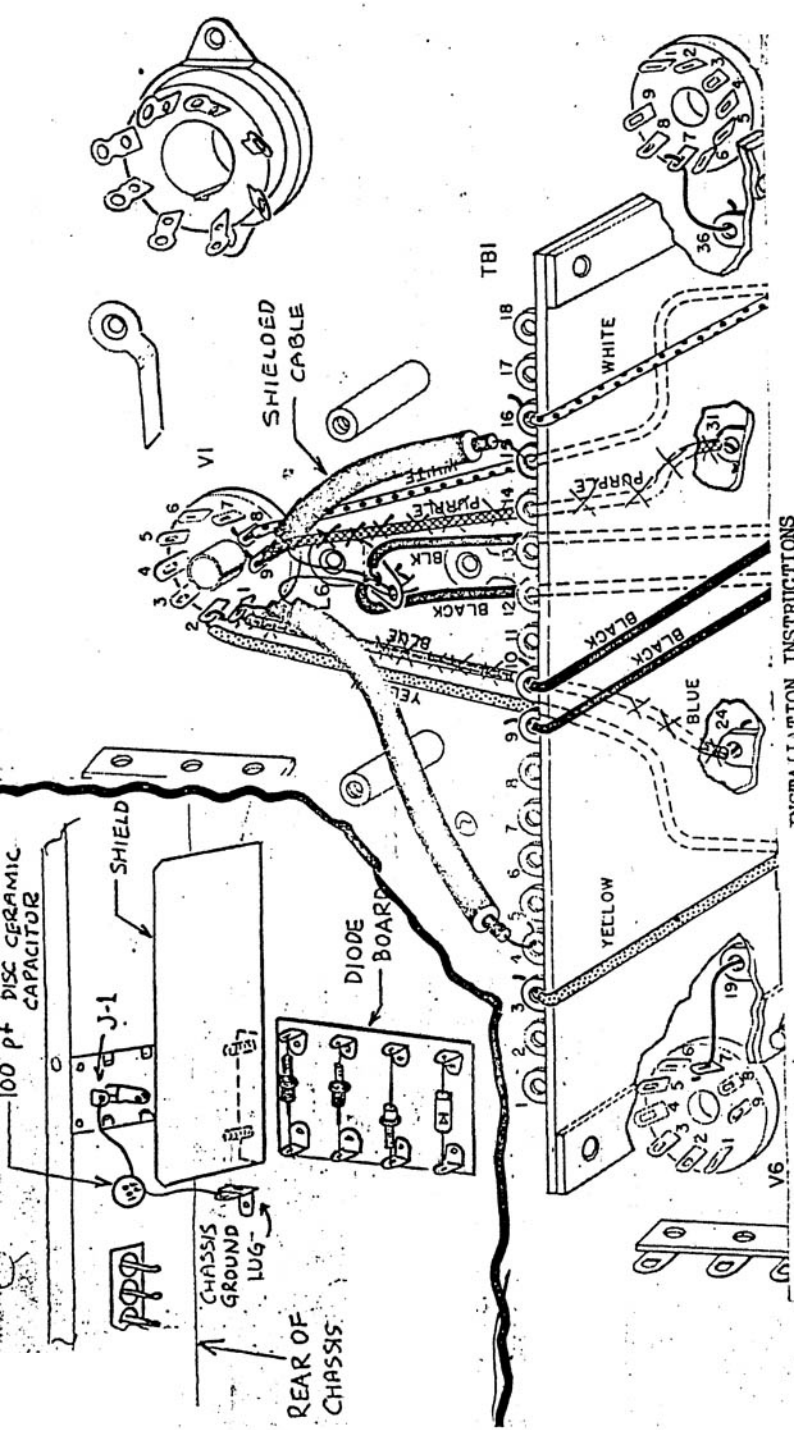

**INSTALLATION INSTRUCTIONS**

1. Remove the blue wire connecting lug 24 of TB-1, and pin 1 of V-1.
2. Install a shielded cable from lug 4 of TB-1 and pin 1 of V-1. Resolder lugs.
3. Remove the purple wire connecting lug 31 of TB-1, and pin 9 of V-1.
4. Install a shielded cable from lug 15 of TB-1 and pin 9 of V-1. Resolder lugs.
5. Solder the shield wires from both of these cables to ground lug L-6.
6. Remove the two transformer nut-washers on either side of input jack J-1. Install the shield as shown using the same nuts. Be sure the shield is not shorted against any wires or components.
7. Install a 100pf disc cermaic capacitor between the ground lug of J-1 and the chassis ground lug as shown. Be sure the lead wires do not touch the shield.