

dbx
Model 200X
Program-Route Selector

Instruction Manual

CONTENTS

Inspection and installation	2
Introduction	3
Front panel	4
Rear jacks and connections	6
Block diagram	10
Some typical hookups	11
Usage notes	12
Warranty and factory service	17
Schematic	18

INSPECTION and INSTALLATION

Your unit was carefully packed at the factory in a carton designed to protect it. Nevertheless, we recommend examining both carton and contents for any signs of damage that may have occurred during shipping. If there is any evidence of damage, don't destroy the carton or any of the packing material, and notify your dbx dealer immediately.

In any case it is a good idea to save the carton and packing materials should you ever need to ship your unit in the future.

In addition to a model 200X and this instruction manual, the carton should contain:

- 1) a set (two pairs) of hookup cables with RCA phono, or pin, jacks;
- 2) a warranty/registration card;
- 3) a pair of brackets for mounting the model 200X into a standard 19-inch(483-mm)-wide equipment rack. (See Fig. 1.)

No cooling or ventilation is required in any installation. If necessary, you can stack other components on the model 200X, although you may wish to keep the top clear because a diagram (Fig. 2) showing the cable routings of typical hookups has been screened there.

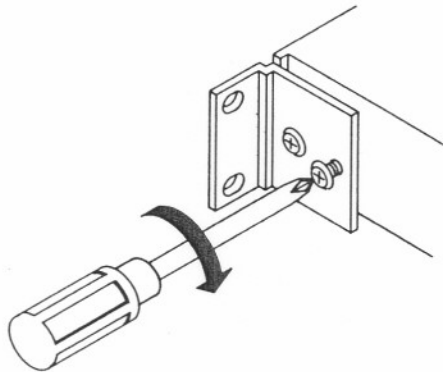

Figure 1: Rack-mounting the unit

INTRODUCTION

The dbx model 200X Program Route Selector is designed to solve the problems of hooking up a complicated hi-fi. The 200X makes it possible to connect and easily use as many as three tape decks, a noise-reduction system, and at least three sound processors through just a single tape-monitor loop on your preamp, receiver, or integrated amp.

Further, any and all of the sound processors may be switched in to modify the signal before recording, letting you make tapes the way you want. On playback, even further processing can be applied.

In other words, the model 200X lets you quickly and precisely select the route you want any program signal to follow before you listen to it *or* before you tape it. And the model 200X does all this without adding anything to the sound, since it doesn't even plug into the wall. It just connects everything together.

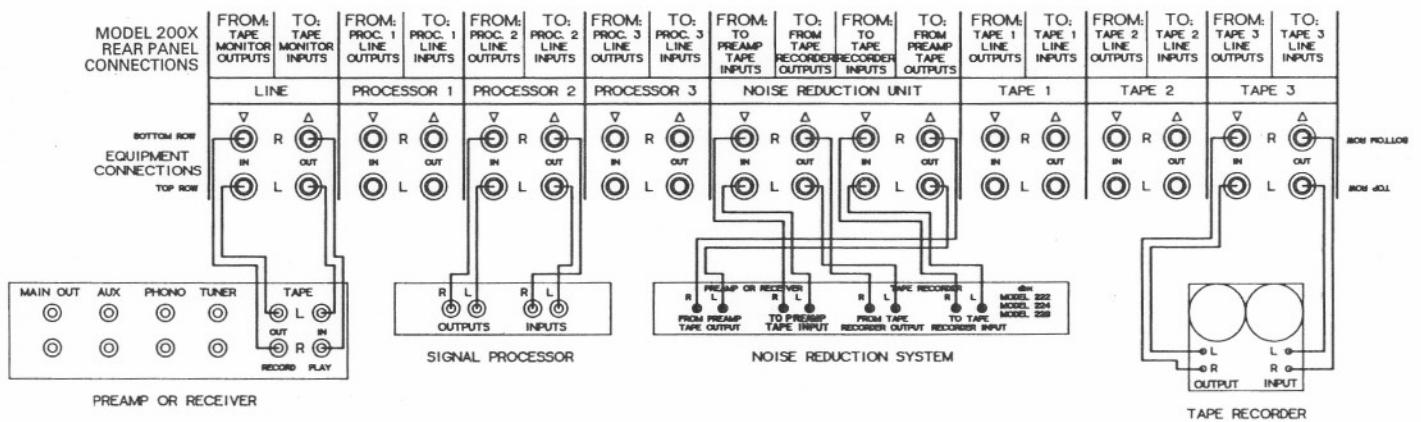

Figure 2: The model 200X top-panel diagram

READ THIS FIRST

The best place to locate your dbx 200X is in a tape-monitor (record/play) loop in your preamp or receiver ("preamp" from now on). If you have more than one such loop, Tape 1 is the obvious choice. The details about this hookup are given in the next section, "Rear Jacks."

For now, simply note that in order for your new 200X to be in operation -- that is, in the signal path -- the signal always has to be going to and from it. In other words, if you've connected the 200X in the Tape 1 loop, leave the preamp set to monitor Tape 1. If your preamp is one of those that have separate Input Select and Rec Out switches, leave the Select knob (or whatever) on Tape 1 and choose the program source with the Rec Out knob. See "Usage Notes."

FRONT PANEL

(See Fig. 3)

1 SOUND PROCESSORS 1,2,3 (buttons)

These buttons let you switch into and out of operation the sound processor(s) (equalizer, imager, expander, etc.) connected to the model 200X in the correspondingly numbered loops.

Push these buttons (to IN) to send the program signal through whatever processor(s) are hooked up. Disengage them (BYP) to bypass the processor(s).

The numbers 1, 2, 3 are the order — first, second, and third — in which the processors act on the signal.

2 POST/PRE (button)

This button lets you put the selected processor(s) in front of, or before, the taping process.

Push it in (to PRE) and you can use one or all of the processors to alter the program signal before it gets taped. Most of the time, however, it's better to change the sound of a tape during playback, with this button disengaged (POST). See the *Usage Notes*.

3 MONITOR (button and knob)

This button and knob let you choose which program signal to listen to, one from a tape deck or one from a record player, radio, or other source.

3A LINE/TAPE button

Push this button in (to TAPE) to listen to, or monitor, one of your tape decks, as selected by the MONITOR:TAPE 1, TAPE 2, TAPE 3 knob.

Leave this button out (at LINE) to listen to the record player or radio (or TV or other "auxiliary" signal) from your preamp (or receiver or integrated amp).*

3B TAPE 1,TAPE 2,TAPE 3 knob

This selects which tape recorder is to be listened to, as just described, when the LINE/TAPE button is depressed (to TAPE).

4 REC SELECTOR (knob and three buttons)

This knob and these buttons control what can be recorded on your tape deck(s).

4A LINE/COPY buttons

Leave these buttons out (at LINE) to tape broadcasts or records, operating your tape deck as usual. Push them in (to COPY) to make a copy (dub) *on* that recorder *from* one of your other recorders, as chosen by the REC SELECTOR:TAPE 1,2,3 knob, discussed next.

When these buttons are left out (at LINE) the REC SELECTOR: TAPE 1,2,3 knob has no effect.

*Hereafter, "preamp" will be used to mean preamp, receiver, or integrated amp.

4B TAPE 1, TAPE 2, TAPE 3 knob

This knob chooses the tape deck to be copied *from* (dubbed) when the LINE/COPY button(s) are pushed in (to COPY), as just explained. It doesn't do anything when the buttons are disengaged (left out, at LINE).

To sum up: when the buttons are pushed in (to COPY), the correspondingly numbered tape deck can make a copy of whatever's playing on the deck the knob is turned to. The buttons select the deck to *do* the dubbing (make the copy); the knob selects the deck to be dubbed *from*, choosing the playback you wish to make a copy of. (See Fig. 4.)

Nothing happens when one of the buttons is depressed (to COPY) and the knob is set to the same tape recorder.

Note: this copying or dubbing is *direct*, from tape deck to tape deck. The playback program signal does not get routed through any of the 200X's sound-processor loops, nor through the noise-reduction loop. However, if the tape deck doing the dubbing has three heads, you can monitor the copy you're making by turning the MONITOR knob to the deck and pushing in (to TAPE) the LINE/TAPE button.

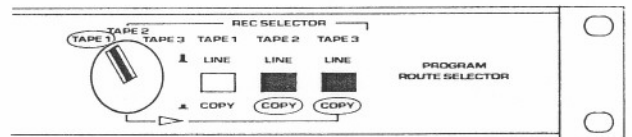

Figure 4: The dubbing function

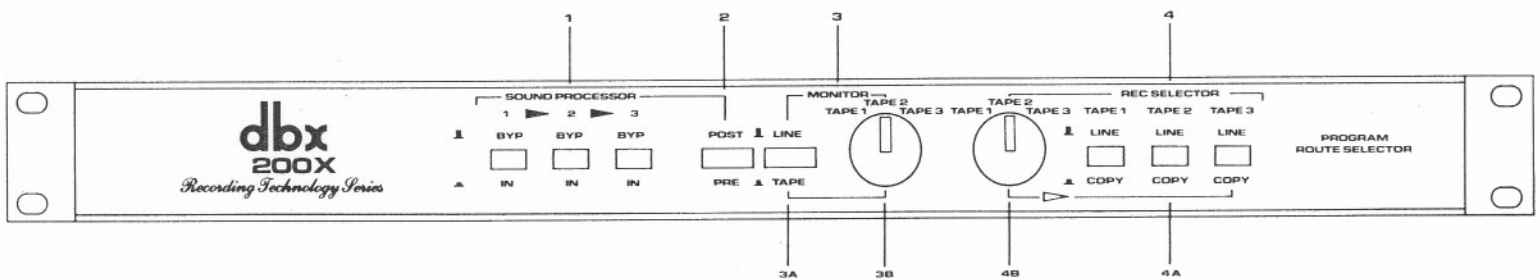

Figure 3: The front

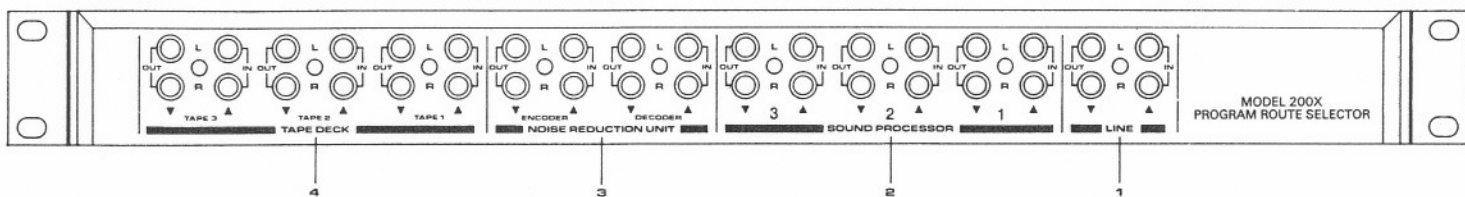

Figure 5: The rear

REAR JACKS

(See Fig. 5.)

1 LINE:IN and OUT, L and R

This is where you hook up the model 200X to your preamp. (See Fig. 6.)

Connect the preamp's TAPE OUT* jacks to the 200X's LINE:IN jacks, left channel to left and right to right. Then connect the 200X's LINE:OUT jacks to your preamp through its TAPE IN** jacks. The triangles show the direction of signal flow.

By the way, the right channel of a cable usually is designated by red plugs, and the left is most often gray or black, sometimes white. Many people simply remember that "red" and "right" start with the same letter.

2 SOUND PROCESSOR 1,2,3:IN and OUT, L and R, with directional triangles

This is where you connect your equalizer (dbx 10/20, or other), imager, expander or other dynamic-range processor (dbx 1BX/3BXIII, 4BX), subharmonic synthesizer (dbx 120X), perhaps a second preamplifier, and so on. (See Fig. 6)

Choose which SOUND PROCESSOR loops to hook up your processor(s) in — see *Usage Notes* — and connect the model 200X's chosen SOUND PROCESSOR:OUT jacks to the *input* jacks of the corresponding processor. Return your processor's output from its *output* jacks to the SOUND PROCESSOR:IN jacks on the 200X in the same loop. Again, the triangles show which way the signal flows.

Do the same for each loop and each of your processors.

*Also called TAPE REC, REC, TO TAPE REC, REC OUT, TO TAPE IN(PUTS), (OUT) TO TAPE, TAPE OUTPUT, etc.; there probably are others.

**Also called PLAY, TAPE PLAY, PLAYBACK, (IN)

• FROM TAPE, FROM TAPE OUT(PUTS), etc.; others here too, probably.

3 NOISE REDUCTION UNIT, ENCODER: and DECODER:IN and OUT, L and R, with directional triangles

This is where to put your dbx 122, 124, 128, 222, 224X, 228 or other noise-reduction unit, or a dbx 21 (see also *Usage Notes*).

If you do not have such a unit to connect here, leave in place the jumper wires that come plugged into these jacks. (They're the ones that look like U-bolts.) If you pull them out, no signal can get from your preamp to your tape deck(s) or from your tape deck(s) to the signal processors. (See top of Fig. 6.)

The NOISE REDUCTION UNIT jacks are divided into ENCODER:IN and OUT and DECODER:IN and OUT, with the triangles pointing accordingly.

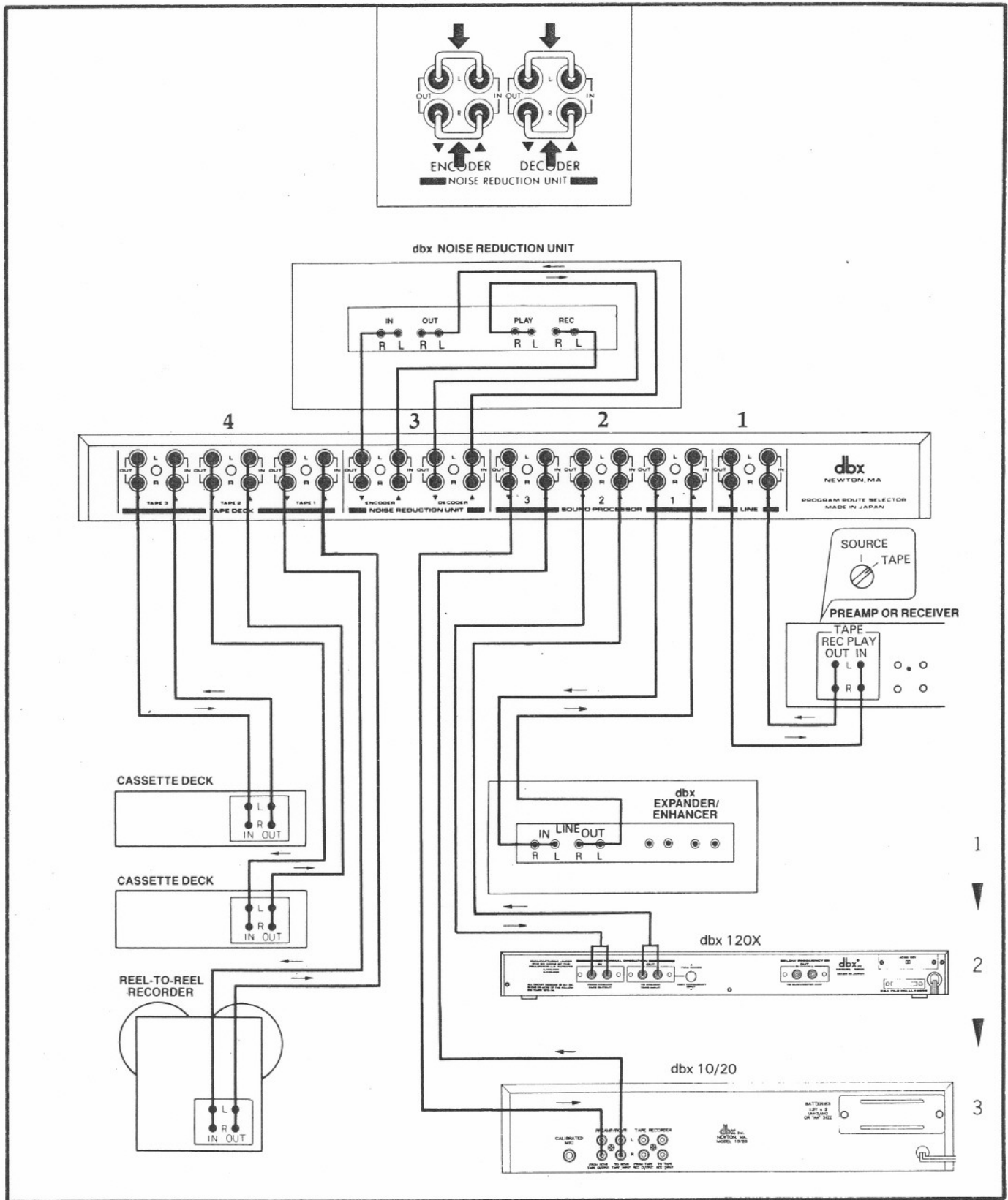

Figure 6: Hookups, by group

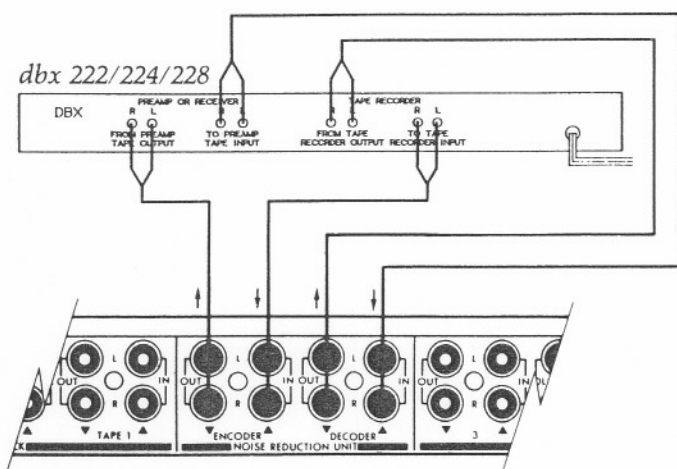

Figure 7: 220 series hookups

HOOKUP for the dbx 222, 224X, and 228
(See Fig. 7.)

Connect the 200X's ENCODER:OUT jacks — "encoder out" means "out to encoder" — to the FROM PREAMP TAPE OUTPUT jacks on the PREAMP/RECEIVER side of your unit. Then connect the ENCODER:IN jacks ("in from encoder") to the TO TAPE RECORDER INPUT jacks on the TAPE RECORDER side.

Likewise, connect the 200X's DECODER:OUT jacks ("out to...") to the FROM TAPE RECORDER OUTPUT jacks on the TAPE RECORDER side of the 222/4/8, and its TO PREAMP TAPE INPUT on the PREAMP/RECEIVER side gets connected to the 200X's DECODER:IN ("in from decoder").

HOOKUP for the dbx 122 and 128
(See Fig. 8.)

Connect the 200X's ENCODER:OUT jacks to the 122/8's RECORD:INPUTS:FROM PREAMP TAPE OUTPUT jacks, and the ENCODER:IN jacks receive cables from the 122/8's RECORD:OUTPUTS:TO TAPE RECORDER AUXILIARY OR LINE INPUT.

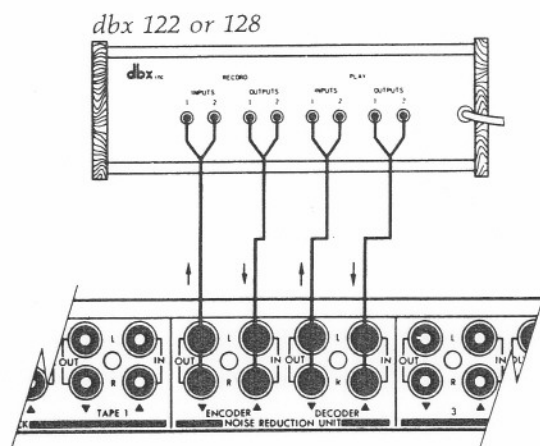

Figure 8: 122/128 hookup

Likewise, connect DECODER:OUT to PLAY:INPUTS:FROM TAPE RECORDER OUTPUT, and the PLAY:OUTPUTS:TO PREAMP TAPE OR MONITOR INPUT return the signal to the 200X's DECODER:IN.

HOOKUP for the dbx 124
(See Fig. 9.)

Connect the ENCODER:OUT jacks ("out to encoder") to the 124's INPUTS called RECORD:FROM PREAMP TAPE OUTPUT nos. 1 and 3. Then connect the 200X's ENCODER:IN jacks ("in from...") to the 124's OUTPUTS called RECORD:TO TAPE RECORDER AUXILIARY OR LINE INPUT nos. 1 and 3.

Likewise, connect DECODER:OUT ("out to...") on the 200X to the 124 INPUTS called PLAY:FROM TAPE RECORDER OUTPUT nos. 2 and 4, and return the signal from the 124's OUTPUTS called PLAY:TO PREAMP TAPE OR MONITOR INPUT nos. 2 and 4 to the DECODER:IN ("in from decoder").

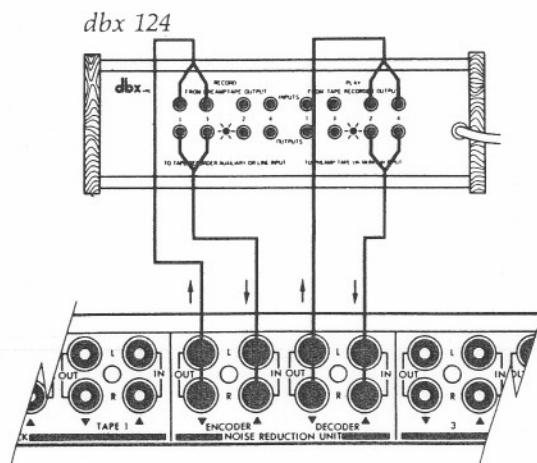

Figure 9: 124 hookup (note vacant jacks)

Since the 124's nomenclature is the most complicated, its hookup will go more easily if you designate jacks 1 and 2 as left and jacks 3 and 4 as right (red). Don't use the RECORD side's pairs of jacks numbered 2 and 4 or the PLAY side's pairs of jacks numbered 1 and 3; they're okay left empty, without anything plugged into them.

HOOKUP for a dbx 21

If you are using the model 21 disc/tape decoder in the 200X's noise-reduction loop, connect it as you would a 120 or 220 series noise-reduction unit. That is:

- ENCODER:OUT goes to the 21's RECORD:INPUTS:FROM PREAMP TAPE OUT;
- ENCODER:IN receives the 21's RECORD:OUTPUTS:TO TAPE RECORDER AUXILIARY OR LINE INPUT;
- DECODER:OUT goes to the 21's PLAY:INPUTS:FROM TAPE RECORDER OUTPUT;
- and DECODER:IN receives the 21's PLAY:OUTPUTS:TO PREAMP TAPE OR MONITOR INPUT.

But also see the *Usage Notes* for a discussion of where best to locate a dbx 21 decoder. It can go in one of the SOUND PROCESSOR loops instead of the NOISE REDUCTION UNIT loop, if necessary.

HOOKUP for an encode/decode noise-reduction unit that's not a dbx (e.g., a Dolby B) (See Fig. 10.)

If your noise-reduction system is not a dbx model, the labels on its input and output jacks probably will be different, but the connections with the 200X will be analogous to the previous descriptions, for dbx equipment.

It may help to figure out the encode and decode sides of the non-dbx unit; sometimes the former is called "Record" and the latter is "Play." Other times non-dbx noise-reduction systems are divided into "Preamp (or Receiver)" and "Tape (Recorder)."

In any case, the 200X's ENCODER:OUT connects to the noise-reduction unit's "From Preamp (Tape) Out(put)"/"Line In(put)"/"From Tape Rec"/"To Amp Rec Out" on its Preamp side (also "Record").

ENCODER:IN receives cables from "To Tape"/"To Tape Record(er) In(put)"/"Tape Rec Out" on the outboard unit's Tape Recorder side (again "Record").

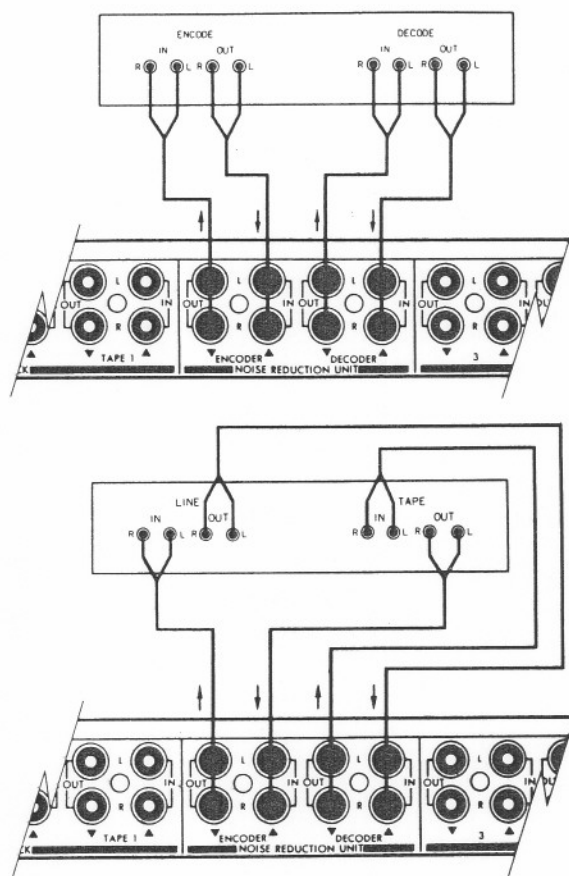

Figure 10: Examples of connections for non-dbx noise-reduction units. See text for various nomenclature.

DECODER:OUT goes to "From Tape"/"From Tape Record(er) Out(put)"/"Tape Play In" on the Tape Recorder side of the non-dbx unit (also "Play," this time).

And DECODER:IN gets connected to "To Preamp (Tape) In(put)"/"Line Out(put)"/"To Tape Play"/"To Amp Tape (Monitor) In" on the Preamp side (again "Play") of the outboard unit.

4 TAPE DECK:TAPE 1,2,3:IN and OUT, L and R (Refer back to Fig. 6.)

This, of course, is where you connect your cassette deck(s) and/or your reel-to-reel recorder(s).

The hookup is simple. Connect the 200X's TAPE (1,2, or 3):OUT to the INPUTS or LINE IN or FROM PREAMP TAPE OUT on your deck, and return its OUTPUT or TAPE OUT or whatever to the 200X's TAPE:IN (same loop number as going out, naturally).

BLOCK DIAGRAM

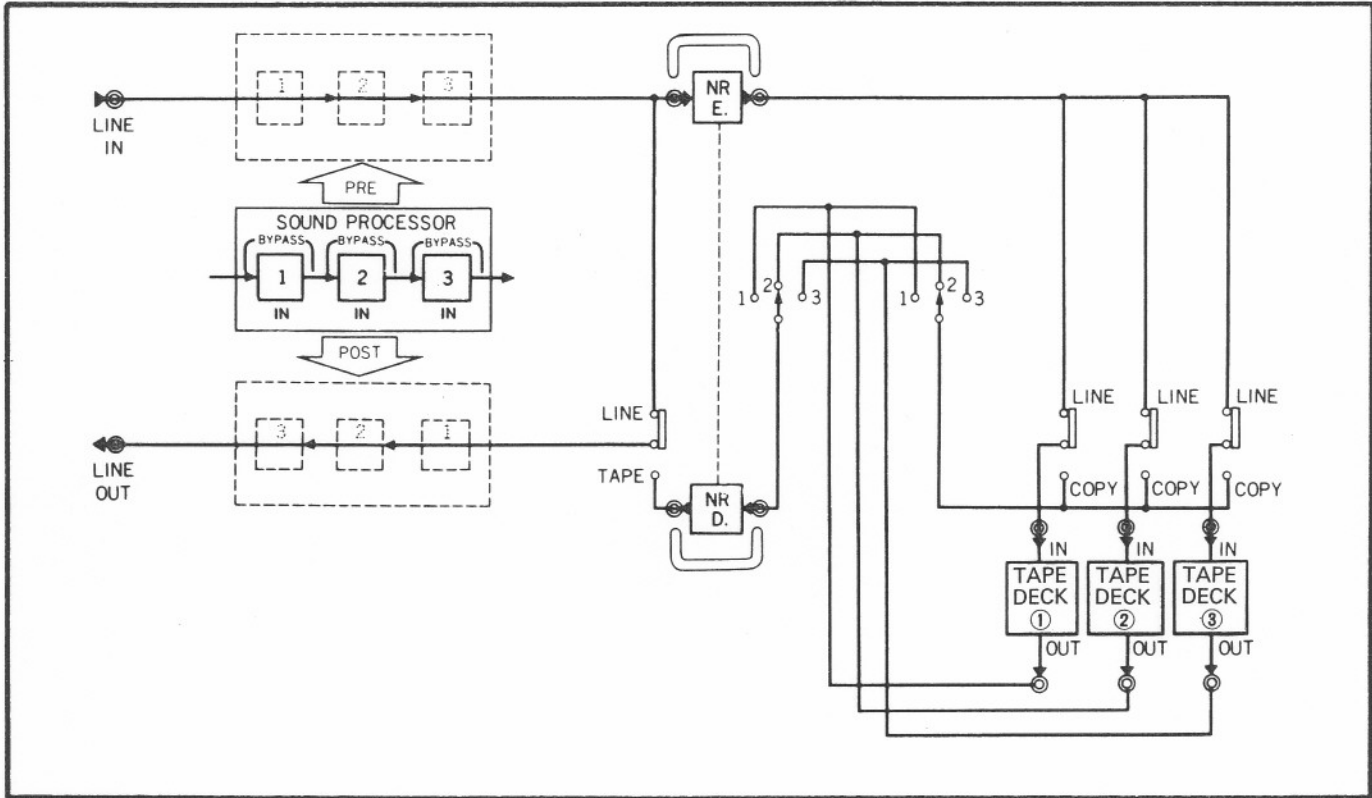

Figure 11: Block diagram of the model 200X

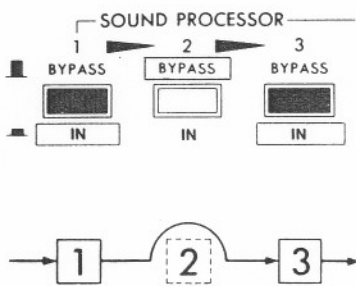
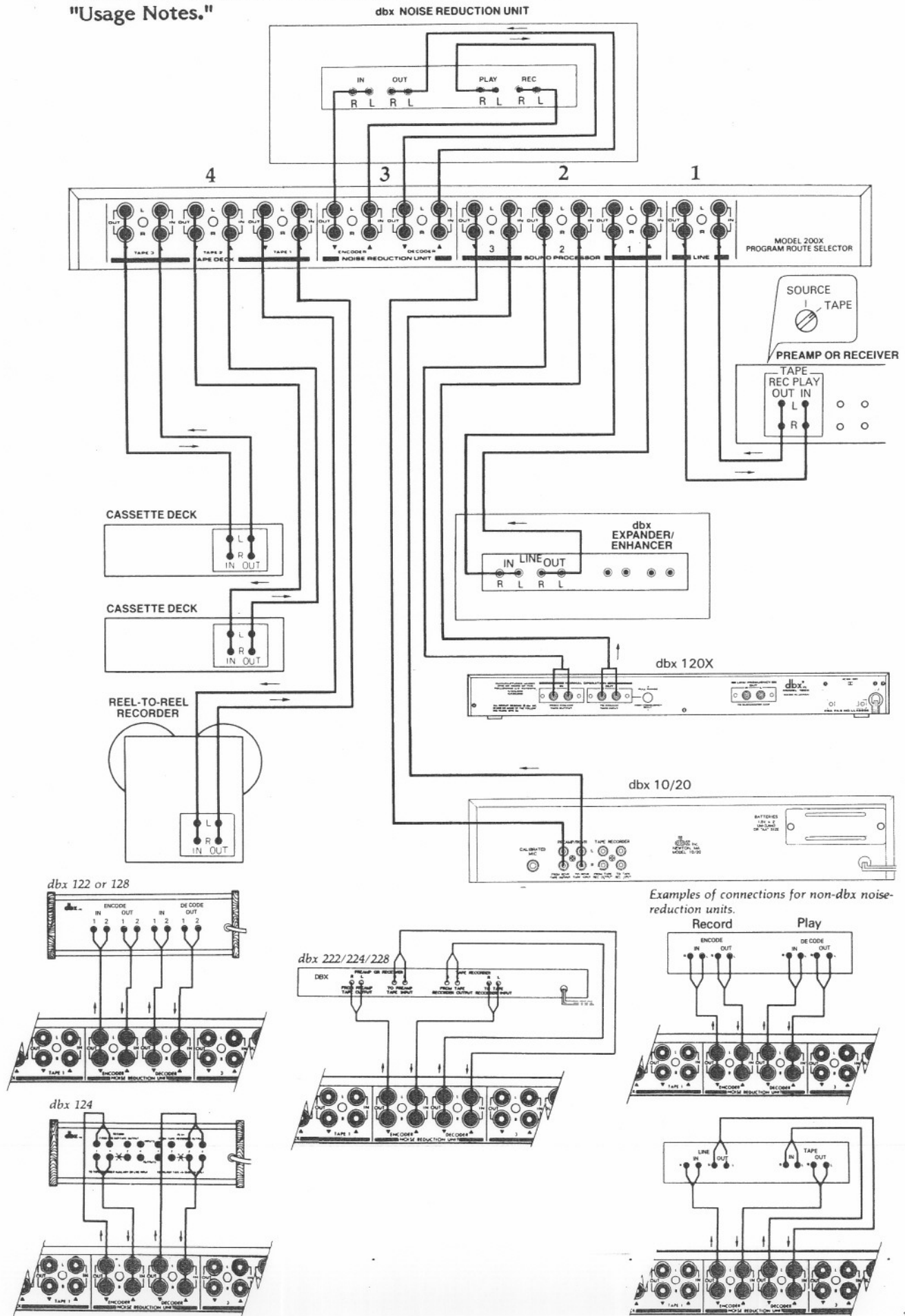
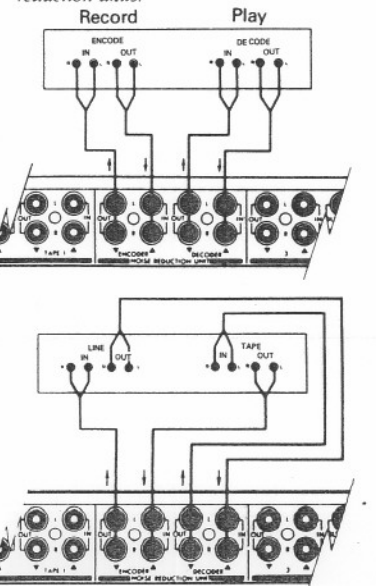

Figure 12: Sound-processor sequence

SOME TYPICAL HOOKUPS of dbx and other components with various labeling; also see "Usage Notes."



Examples of connections for non-dbx noise-reduction units.



USAGE NOTES

To get the most out of the dbx model 200X, you must give some thought to the order in which to connect your other equipment.

As mentioned earlier, the 200X will be most useful if it's in (one of) the tape-monitor loop(s) of your preamp. If yours has two tape loops, we recommend that the 200X go in the first, leaving the second free for the future. An alternative location for the 200X is in the so-called external-processor (EP) loop of certain preamps, although if you hook it up there you lose flexibility both in your preamp and in the 200X.

Also as mentioned, to use the 200X in Tape 1 -- to get signal to and from it -- you will have to leave the Tape 1 switch (usually a button) in. However, if your preamp has those separate "Input Selector" and "Record Out" selection switches (knobs, usually), you must leave the unit's Input Selector knob (or tape-monitor switch) set to Tape 1 and use the Rec Out knob to choose the program source that you want to listen to and route through the 200X. We emphasize this because the impulse of most people is the opposite.

Now. Once you've hooked up the 200X, the order becomes important, because it affects what sound changes you can obtain. As noted, the model 200X sends the program signal through the (up to) three connected processors in order, 1 to 2 to 3. If the corresponding button is in, the processor in Sound Processor (SP) loop 1 gets the signal first, after which it's passed to the processor in loop 2, and so on. If the button is disengaged or left out, naturally, the signal bypasses that loop and proceeds to the next.

If a processor has its own tape-monitor loop, of course, hookups of more than three are entirely possible. And if one of the initial three has a Pre/Post switch, that's the place to put a fourth unit for maximum flexibility: you can experiment with switching it before and after the processor with Pre/Post.

Since it's impossible to suggest a "perfect" order for all signal processors, we must emphasize that this section contains guidelines only. Your own good judgment is called for in any complex arrangement of your stereo system. Careful experimentation with various combinations and sequences of hookups will enable you to find out what works best.

Equalizers

User-controlled "graphic" equalizers (EQs) -- commonly having one-octave nominal filter settings -- are employed by some people as much to change the sound of the musical program as to correct for large irregularities in the response of the speakers and room. This kind of equalization is perhaps the most basic sound processing to be done, so if you follow the practice, your equalizer should be placed early on in the 200X's signal path, probably in SP loop 1.

However, there are automatic equalizers -- the dbx 10/20 and 20/20, for example -- whose job is to make the speakers and room flatter in combination. These should be put in the last processor loop, so that no further alterations of the signal take place, downstream from it. The reason for this is that these equalizers use a test signal to do their job, and if this signal gets changed, the automatic-equalization results won't be correct. Thus SP loop 3 is the best place for such an EQ. (If for some reason you find it most convenient after all to place a sound processor after an automatic equalizer, everything will be okay if you

make sure that that processor is out or bypassed during the equalization process.) The third category is equalizers that come with your speakers to improve their response, usually at one or both ends of the audio band (Allison, Bose, dbx, EV, McIntosh, etc.). Such a dedicated equalizer must do its work after the 200X, making the final correction. It might be placed in a tape-monitor (Tape 2) or external-processor (EP, SP, etc.) loop, or it can be put between preamp and power amp if you have separates. (Follow the manufacturer's directions.) This advice also pertains to narrow-band parametric or third-octave equalizers used only for changing speaker response and usually left to one setting.

Another solution for this is to put the 200X "inside" the speaker equalizer, in its tape-monitor loop. Your preamp's Tape Out goes to the speaker EQ's Line In (or From Preamp Tape Out), and the EQ's Line Out (or To Preamp Tape In) returns to the preamp's Tape In. Meanwhile, the EQ's Tape Out (or To Tape Recorder In) goes to the 200X's Line:In, and the 200X's Line:Out returns to the EQ's Tape In (or From Tape Recorder Out). Note that the speaker EQ itself is always set to its Tape Monitor.

Bass Reinforcers

A subharmonic synthesizer -- the dbx 120 or its predecessors (the 100, 110, 500) -- should follow a user-controlled program-source equalizer, so that deficiencies in the recording or broadcast can be somewhat corrected before the synthesizer gets the signal. In other words, the subharmonic synthesizer should have the best possible signal to work with.

However, an automatic equalizer (the dbx 10/20 or 20/20) or other EQ used principally to equalize speakers should come after a 120. The reason for this is that the low frequencies created by the synthesizer will then be reproduced by the smoothed-out system, and the synthesizer won't have to operate on a signal already modified for room/speaker irregularities. Likewise, other components that process the bass as well as boost it should be placed after a program EQ but before an automatic EQ.

Dynamic-Range Expanders and the like

Expanders, such as a dbx 1BX Series Two, 3BX Series Two, or 4BX (or their predecessors), and compressor/expander/enhancers, such as the previous dbx models 117/8/9, also should be located after program-source EQ and before automatic EQ. The reasoning is similar to that for bass processors. One, dynamic-range expanders should have as "correct" (in frequency response) a signal as possible to work with. A second reason is that dbx expanders, at least, provide some noise reduction (when they make soft sounds softer they also push down the noise floor several dB). Therefore they will make equalizers quieter, which sometimes is desirable because many of them aren't quite as low in noise as they could be.

In this sequence, some combinations of EQ settings, expanders, and program material may occasionally result in "surging" in the sound at various frequencies. Feel free to switch the order of equalizer and expander to see if there's an improvement.

Finally, if you own both an expander and a bass reinforcer, we recommend the expander be first.

Imagers

These are the devices that alter the stereo image -- its depth and width. They are best placed after everything in the sound-processing chain except

automatic equalizers like the dbx 20/20. Imagers do their job by modifying the phase and phase relationships in the program signal, so they must have close to the last say in changing the sound. The reason the dbx 20/20 can be placed afterward is that it equalizes both channels identically, doing no harm to the phase relationships between them. Note that the dbx 10/20 can equalize the channels either together (identically) or separately (differently), and may follow an imager only if used in the former mode. But imagers still are followed by dedicated speaker equalizers, of course.

Reverb Units

Like imagers, reverb devices should go toward the very end, after everything else but automatic EQs like the dbx 20/20.

Playing (Decoding) dbx Records . . .

You can play dbx-encoded records with any of the previous dbx 122/4/8 or the current 220 series (or NX-40) noise-reduction units, or you can use just the model 21 disc/tape decoder. The hookup and the operation of switches depend on the unit. Your preamp is set to Phono and Tape 1 (if that's where the 200X is).

. . . with a Model 122, 124, 128, or 222, 224, 228, or NX-40

If you have one of these encode/decode units, it should be connected in the model 200X's Noise Reduction Unit loop, as discussed earlier. To play a dbx record, the 200X's SP buttons may be as you desire; the Post button must be in (so that the encoded record signal doesn't get tampered with by any of the signal processors); any one of the three Tape buttons must be in; and both the Decode and the Encode buttons must be in. Everything downstream from these buttons should be out.

Then set the dbx unit for disc decoding according to its instructions. Further signal processing, if selected, takes place as usual, after the record is decoded.

. . . with a Model 21

A dbx model 21 disc/tape decoder, too, can be placed in the 200X's Noise Reduction loop, as noted. In this location the 21 can be used to play back dbx-encoded tapes as well as dbx records. To play the records, the 200X's Post button must be pushed in and one of its Tape buttons must be pushed in. The model 21, for its part, must have its In/Out button pushed In and its Monitor:Tape/Source button disengaged (at Source). (For a tape, of course, the second button is pushed in, to Tape.)

If you want to use your 21 for dbx-record decoding only (and/or the 200X's Noise Reduction loop is occupied with some other NR unit), it may go in the first SP loop -- and only the first. In this case, connect the 200X's SP:Out jacks to the 21's Record:Inputs:From Preamp Tape Output, and the 21's Play:Outputs:To Preamp Tape or Monitor Input jacks return to the 200X's SP:In. Leave the 21's four other (two sets of two) jacks alone. Returning to the front, the 21 should be left in Source with the noise-reduction button In.

To play a dbx record now, the 200X's Line button is pushed in, the SP:1 button is pushed in, too, naturally, and the Post button is in. You can play dbx-encoded cassettes this way as well.

With this setup, tapes of dbx-encoded records will be recorded encoded, to

be decoded on playback. To tape a dbx record in decoded form (to make a Dolby copy, for example), push Pre.

... Through a Cassette Deck with dbx Noise Reduction

All but a few cassette decks with dbx noise reduction offer record-decoding capability, too. To take advantage of this feature when the deck is hooked up in one of the 200X's tape loops, set the Sound Processors to Post, the Monitor to the deck's loop number, and leave Decode/Encode and all the Rec Selector buttons out.

Now follow the instructions in your cassette deck's owner's manual for playing dbx records. (Don't forget to turn up the deck's recording-level control; if it's all the way down, you won't hear the record.) You may, of course, use the sound processors (in Post) connected to the 200X as usual.

Second Noise-Reduction Units

If you wish to use a second noise-reduction unit (say, an outboard Dolby B) in the 200X's Noise Reduction Unit loop, it should go in the dbx unit's tape-recorder loop. The dbx unit's To Tape Recorder Input (or equivalent) jacks go to the second unit's From Preamp (Tape) Out(put)/Line In(put)/From Tape Rec/To Amp Rec Out jacks, and its To Preamp (Tape) In(put)/Line Out(put)/To Tape Play/To Amp Tape (Monitor) In returns to the dbx unit's From Tape Recorder Output or equivalent. The second unit's To Tape Record(er) In(put)/To Tape/Tape Rec Out or equivalently named jacks go to the 200X's Encoder:In, and its Decoder:Out jacks return to the second unit's From Tape Record(er) Out(put)/From Tape/Tape Play In or whatever. See below; it's easier.

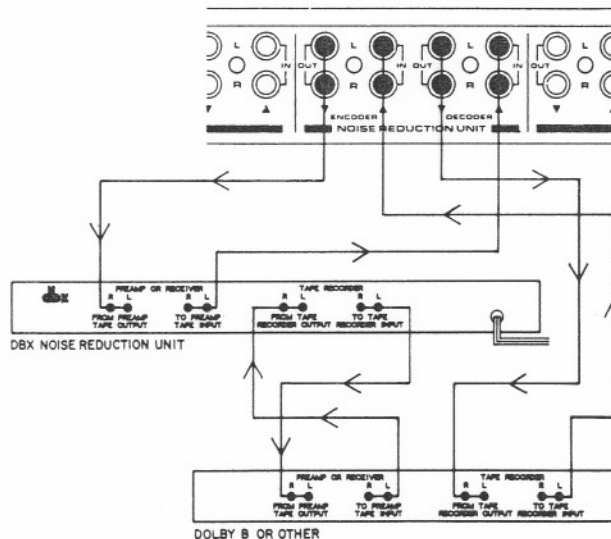

When using dbx noise reduction, it generally is best to switch the other system out, and vice versa.

For more help with other units' nomenclature, see the section on rear-jack connections and following.

One-Way ("Single-Ended," "One-Pass") Noise-Reduction Units

A noise-reduction unit that works on playback only, to decrease the sound of record pops, clicks, scratches etc. or to reduce steadier noise in sources that aren't encoded, should be placed in the next SP loop on the 200X after a dbx record decoder (if you're using one). In any event, it should be early on in the sequence.

Other Processors

Some users might want to put a second preamp in one of the 200X's SP loops because it has a useful filter or two, different tone controls, channel blending for headphone listening, etc. You will want to experiment about where to put it yet not go against guidelines already given. That is, locate it after record decoders and user-controlled EQs and before bass reinforcers, expanders, and automatic EQs. Similarly all other processors: experiment with care, while following any advice in the accompanying instruction manuals.

Four-Channel ("Quad"), Ambience-Recovery, Time-Delay Systems, etc.

The 200X is a stereo (two-channel) component. Rear-speaker processors and the like cannot easily be routed through a single 200X; it's best to do these extra-channel hookups after the signal processing that takes place via the 200X.

Using 200X Loops as Extra Inputs

The 200X's six sound-processor and tape loops can be used as extra inputs if your preamp doesn't have enough of its own. This may well be the case if you have new video, digital/VCR, and/or CD player sources. Note that playback sources will plug directly into the particular "In (from)" inputs on the back of the 200X, with no cables returning to the component from the loop's "Out (to)" jacks.

Using the Pre Button

A warning is in order about pushing in the Pre button, placing the sound processors you have hooked up to the 200X in front of your tape decks. All recorders -- especially cassette decks, and even the very best of those -- can be readily overloaded by too much boosting of a given frequency, particularly in the treble. Reinforcing the bass (particularly, synthesizing subharmonic frequencies) when strong bass is already present, or expanding the dynamic range of material that has wide dynamics to begin with, also will saturate even the newest tapes and cassette desks. And using dbx noise reduction in taping will not prevent this. Always go easy in processing signals before taping.

If a program signal is sonically deficient in its original form -- a dull orchestral broadcast, a heavily compressed FM station, an unbalanced tape, an old record with weak bass -- then careful use of processors during taping may allow tapes to be made that sound cleaner, wider, and better-balanced than the original. But source material that is reasonably good to begin with in these respects -- that's clear, quiet, dynamic and/or well-balanced -- is best recorded straight, without Pre processing.

Remember that any improvements which seem necessary can always be added during playback.

Overdriving

Like tape decks, successive sound processors (ones coming after) can be overdriven by too much voltage. Most dbx equipment is capable of accepting large input levels without distress, and by its very nature, most dbx equipment can produce more signal at its output than it received. This is also true of equalizers when set to boost any frequencies and of spare preamps when their volume controls are set past unity gain. Therefore it's a good idea to pay attention to the maximum input-voltage capacity of all equipment downstream from each processor, and to consider moving up earlier any units that appear

relatively easier to overdrive. One symptom is harsh, grating distortion in the sound. Reduce the outputs of earlier processors and begin thinking about rearranging the order of the units.

A final caution: whenever you rearrange processors (or other equipment), be sure that all volume controls are all the way down and that everything is turned off. After reconnections are made and the units are turned back on, turn the volume controls back up slowly, to allow yourself time to react before doing damage to equipment connected to the 200X, to amplifiers, to speakers (especially speakers) -- or to your ears.

WARRANTY and FACTORY SERVICE

All dbx products are covered by a limited warranty (warranties for products purchased outside the USA are valid only in the country of purchase and the USA). For details, consult your warranty card or your dealer/distributor.

The dbx Customer Service Dept. will help you use this product. For answers to questions and information on problems, write to:

dbx Inc.
71 Chapel St.
Newton, Mass. 02195 USA
Attn: Customer Service

You also may call (617) 964-3210 during business hours (USA Eastern Time). The Telex is 92-2522.

Should it become necessary to have your equipment serviced at the factory:

- 1) Repack the unit, including a note with a description of the problem and the date of purchase;
- 2) Send the unit freight prepaid to the above address, marking it "Attn: Repairs."
- 3) We strongly recommend that you insure the package and send it by United Parcel Service whenever possible.

If you live outside the USA, contact the nearest dbx dealer or distributor for the address of the nearest authorized repair center.

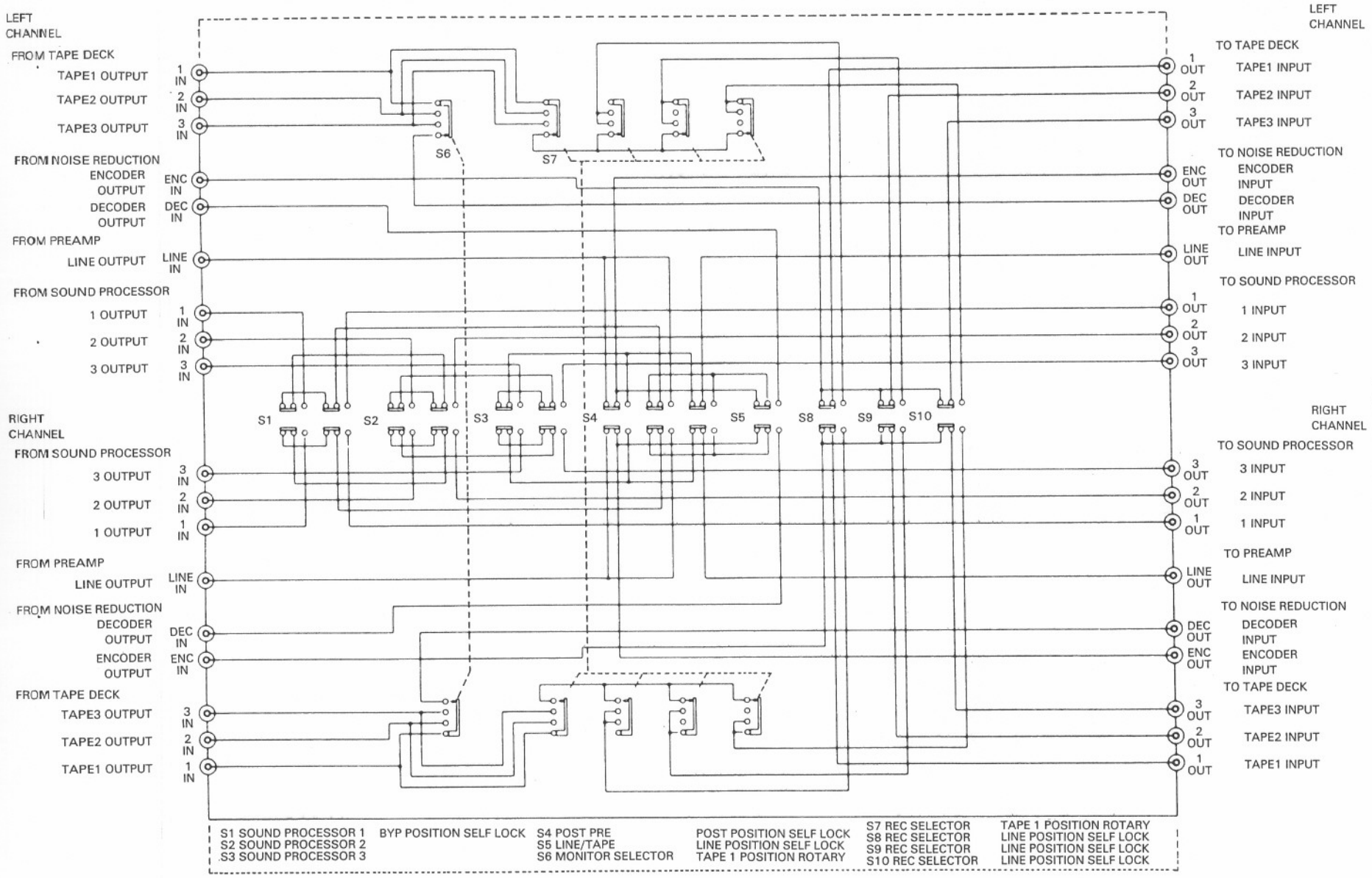

SCHEMATIC

S1 SOUND PROCESSOR 1	BYP POSITION SELF LOCK	S4 POST PRE	POST POSITION SELF LOCK	S7 REC SELECTOR	TAPE 1 POSITION ROTARY
S2 SOUND PROCESSOR 2		S5 LINE/TAPE	LINE POSITION SELF LOCK	S8 REC SELECTOR	LINE POSITION SELF LOCK
S3 SOUND PROCESSOR 3		S6 MONITOR SELECTOR	TAPE 1 POSITION ROTARY	S9 REC SELECTOR	LINE POSITION SELF LOCK
				S10 REC SELECTOR	LINE POSITION SELF LOCK

“dbx” is a registered trademark of dbx Inc.

